

**Aéreo Canto Reto 01 Porta de Vidro Belize |  
Esquina de aire recto 01 para puertas de vidrio Belize |  
Aero Straight Corner 01 Glass Door Belize**

c C506-131 - Cinza

Opção 1  
Opción 1  
Option 1

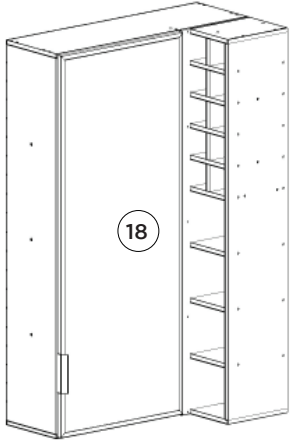

Opção 2  
Opción 2  
Option 2

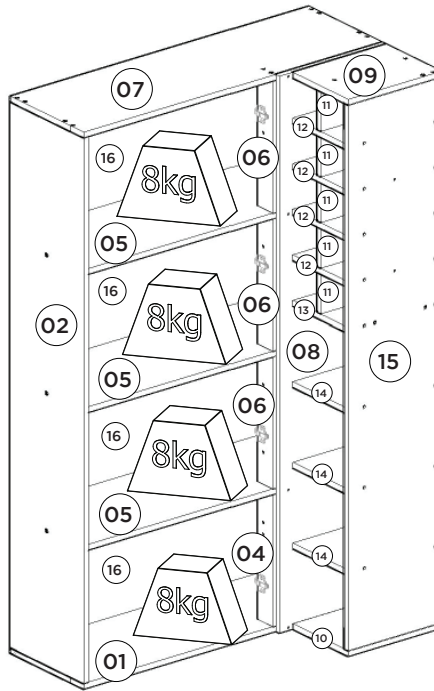
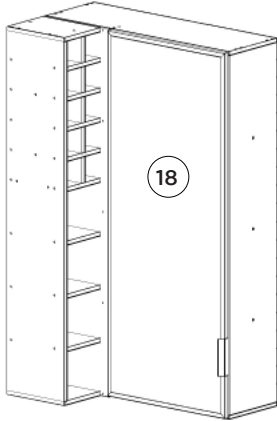

Pesos máximos recomendados com carga distribuída  
Peso máximo recomendado con la carga distribuida  
Recommended maximum weight with distributed load.

Requisitos para montagem  
Requisitos para la montaje  
Assembly Requirements

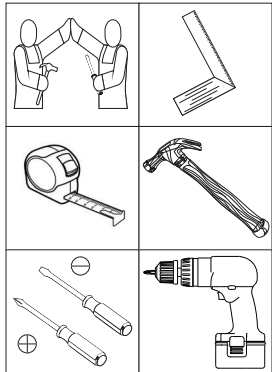

Imagens meramente ilustrativas  
Imágenes meramente ilustrativas  
Images for illustration only

### AVISO

Para limpeza de seu móvel, use uma flanela seca ou umedecida, e não utilize produtos químicos que possam danificar seu produto.

### SISTEMA DE MONTAGEM

O sistema de montagem dos produtos, funciona de acordo com a ordem crescente dos números indicados no desenho. Ex: 01, 02, 03, 04... até a conclusão da montagem.

### ADVERTENCIA

Para limpieza de su móvil, use una franela seca o húmeda, y no utilice productos químicos que puedan dañar su producto.

### SISTEMA DE MONTAJE

El sistema de montaje de los productos funciona de acuerdo con el orden creciente de los números indicados en el dibujo. Ej.: 01, 02, 03, 04... hasta la conclusión del montaje.

### NOTICE

To clean your furniture, use a dry or wet cloth, and do not use chemicals that may damage your product.

### ASSEMBLY SYSTEM

The products' assembly system works according to the increasing order of the indicated numbers. For example: 01, 02, 03, 04 ... to the end of the assembly.

1º

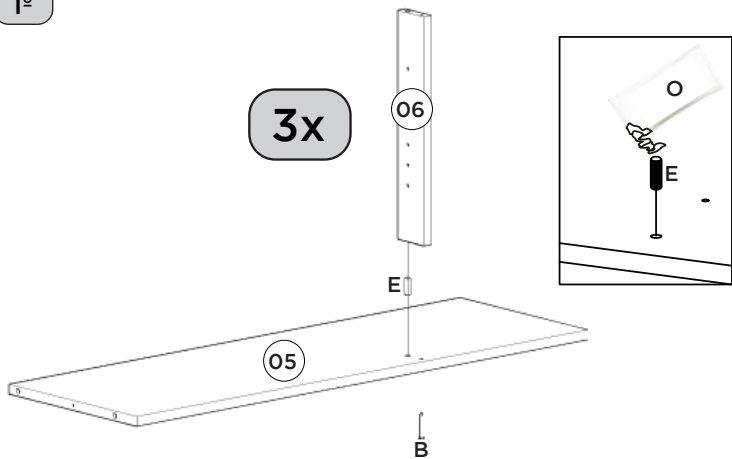

Utilizar o sachê de cola (O) em todas as cavilhas (E) do produto.

Con el pegamento sobre (O) en todos los pernos (E) producto.

Use the glue sachet (O) on all the pegs (E) of the product.

2º

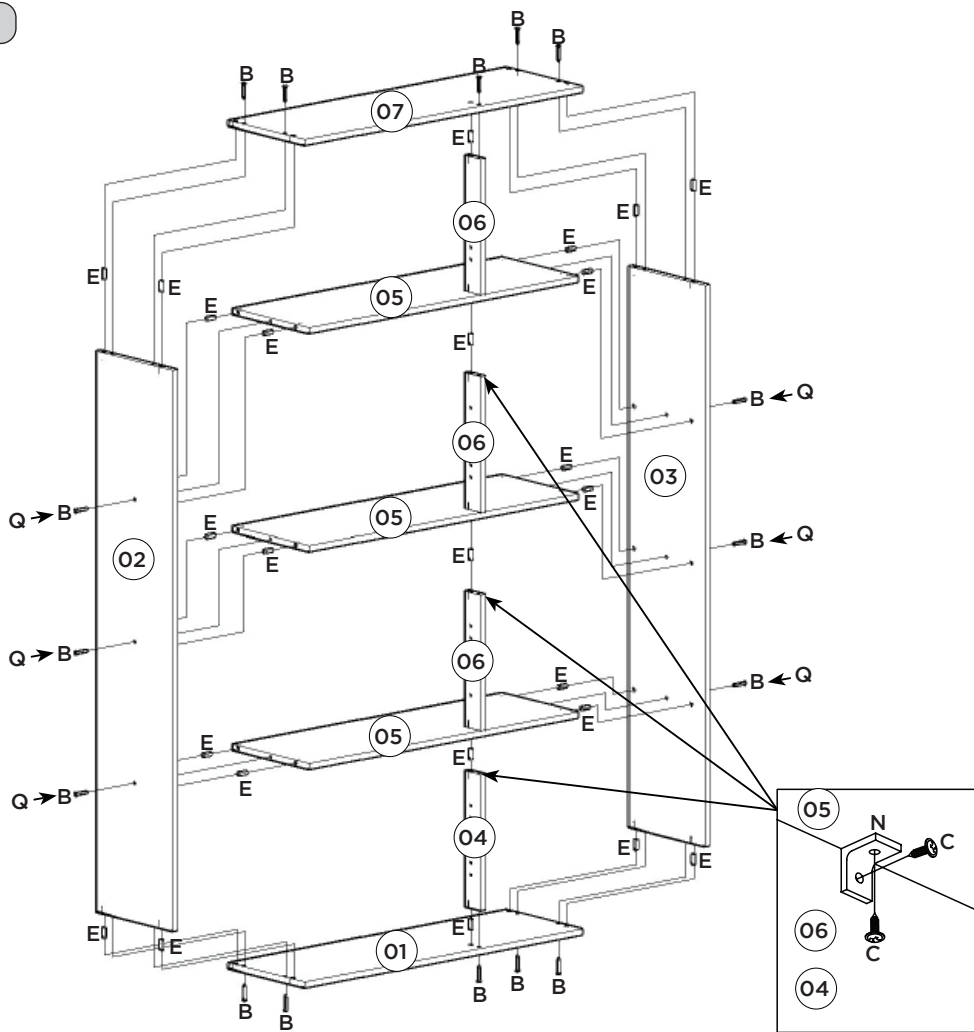

3<sup>e</sup>

ITM/C506-

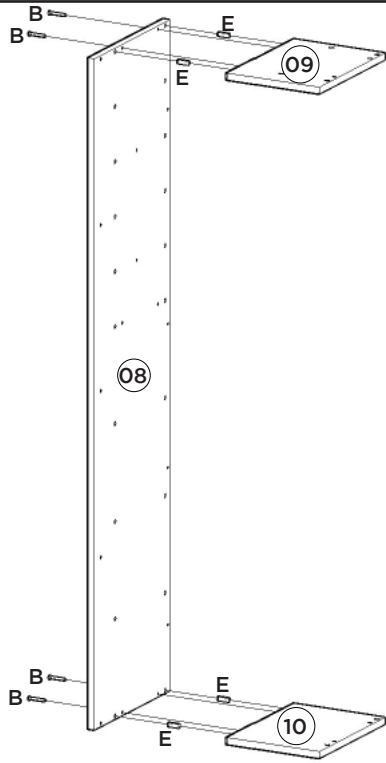

4<sup>e</sup>

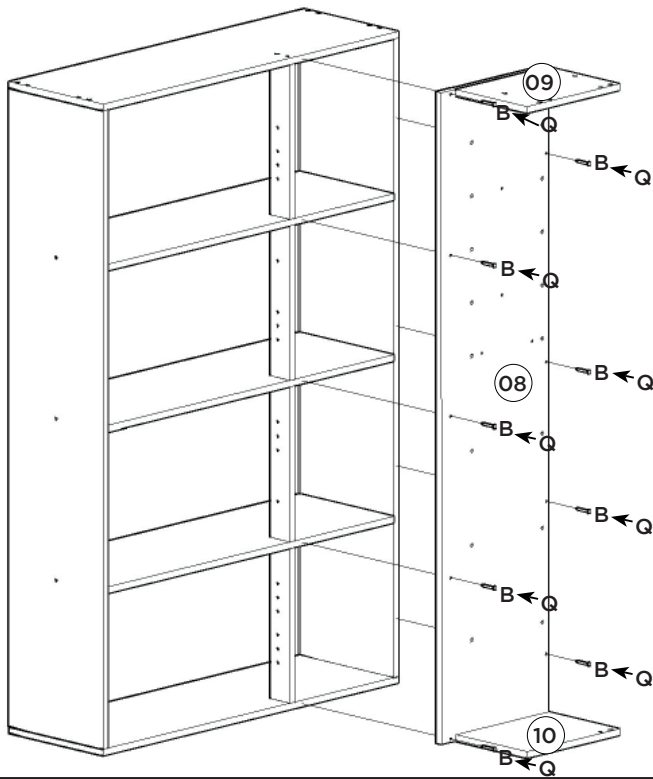

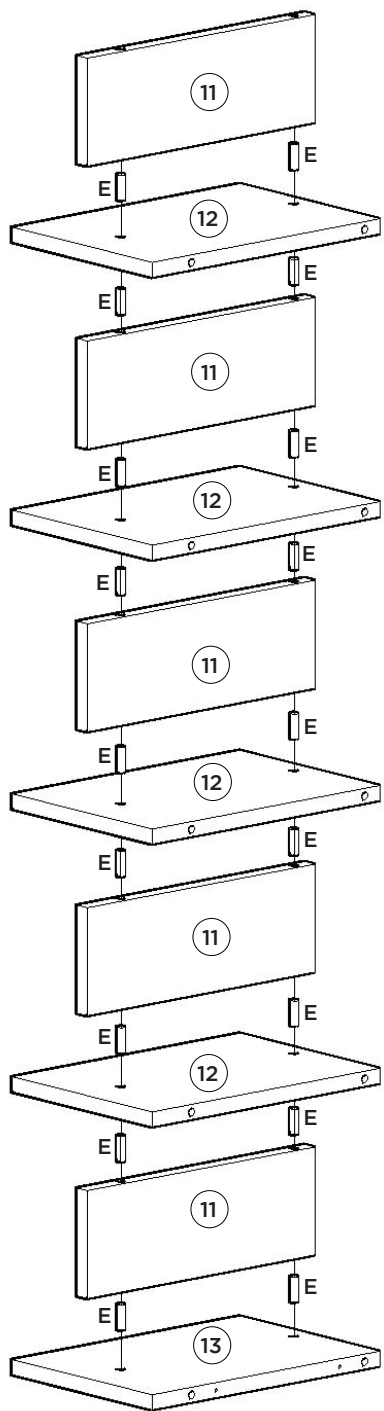

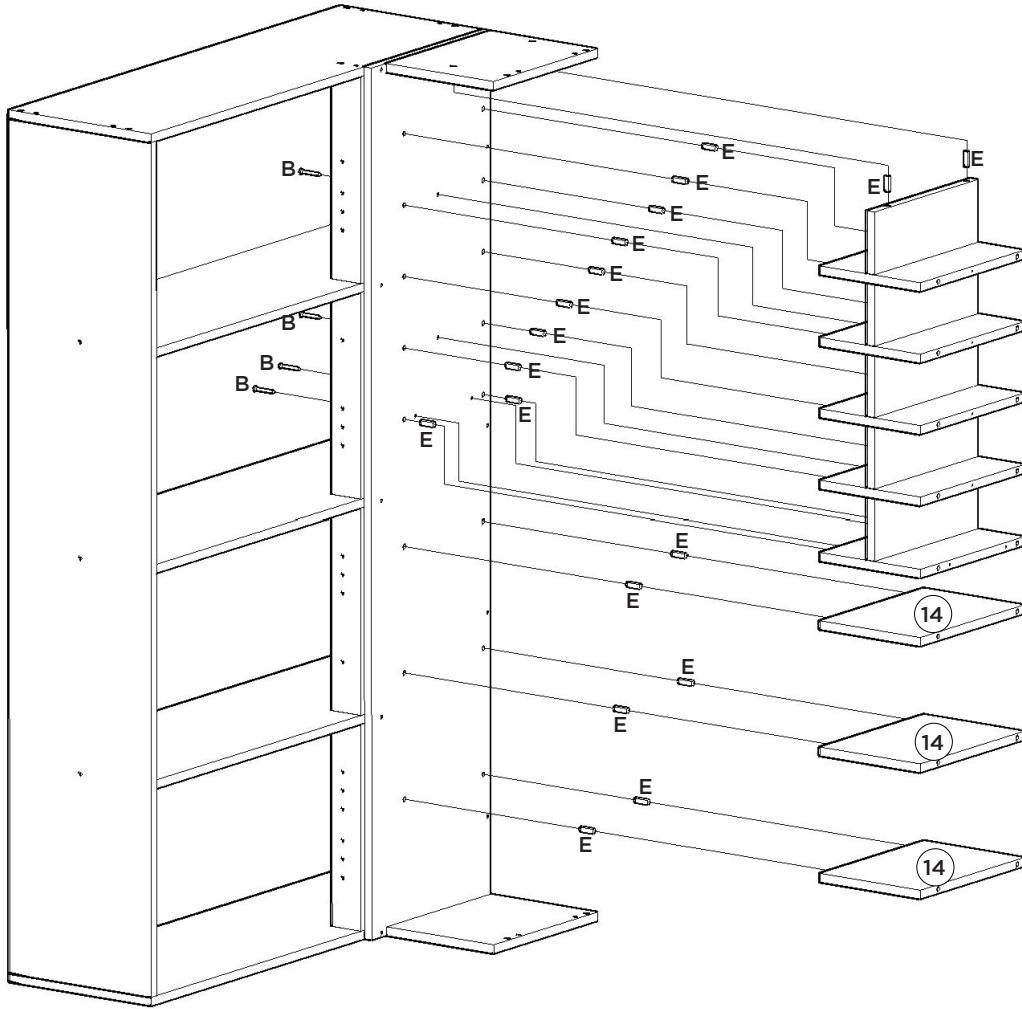

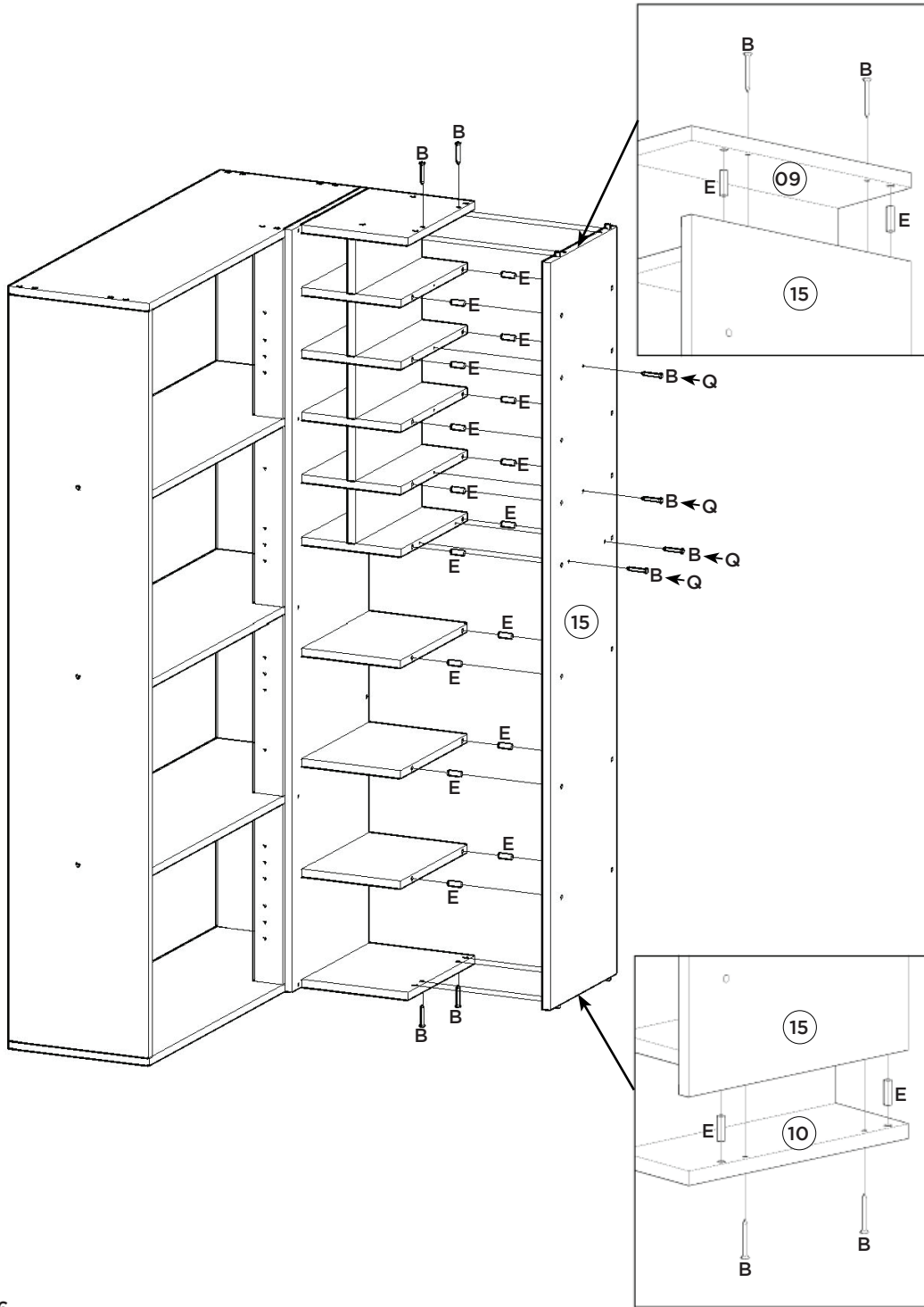

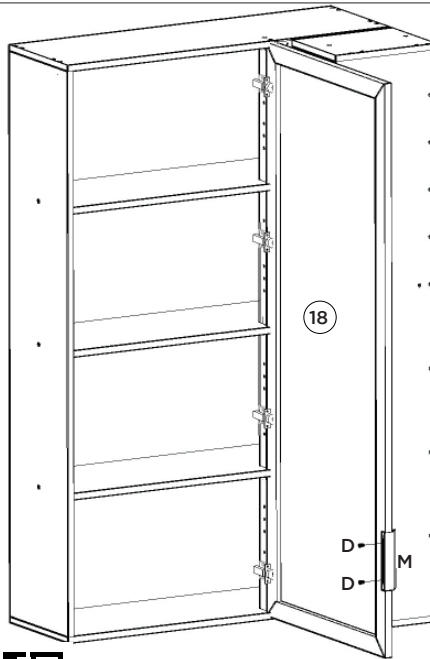
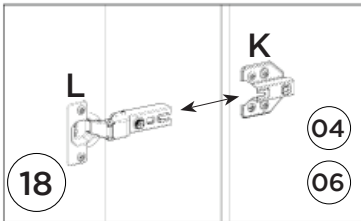
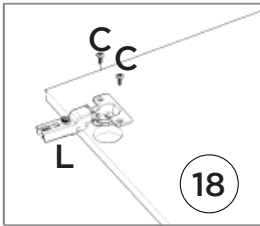
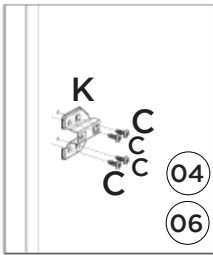
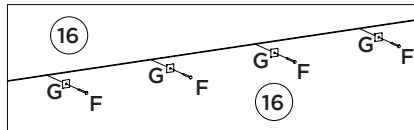
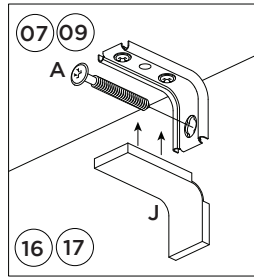
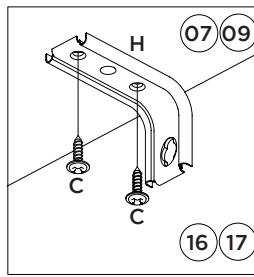
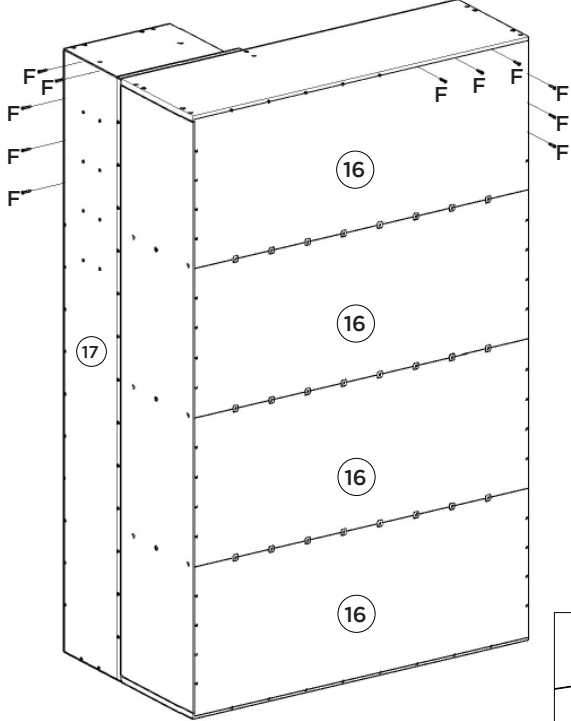













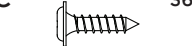

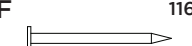

Vídeo: Instalar e regular Dobradiças

Video: Instale y ajuste las bisagras

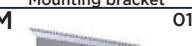
Video: Install and adjust hinges

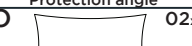
Item	Caixa Caja Box	Qty Ctd Qty	Descrição   Descripción   Description	Medidas (mm)   Dimensions (mm)   Size (measurements) (mm)
01	1/2	01	Base   Base   Base	940x295x15
02	1/2	01	Lateral Esquerda   Lateral Izquierda   Right Left	1470x295x15
03	2/2	01	Fundo 15mm   Fondo 15mm   15mm Bottom	1470x295x15
04=06	1/2	01	Pilastra da Porta   Puerta Pilastra   Door Pilaster	356x60x15
05	1/2	03	Prateleira Maior   Estante más grande   Larger Shelf	910x295x15
06=04	1/2	03	Pilastra da Porta   Puerta Pilastra   Door Pilaster	356x60x15
07	1/2	01	Tampo   Tapa   Top	940x295x15
08	2/2	01	Frente Fixa   Frente Fija   Fixed Front	1500x337x15
09	1/2	01	Tampo Nicho   Nicho superior   Niche top	295x223x15
10	1/2	01	Base Nicho   Nicho base   Base Niche	295x223x15
11	1/2	05	Divisão Nicho   División de nicho   Niche Division	293x108x15
12	1/2	04	Prateleira Nicho   Estante de nicho   Niche Shelf	295x208x15
13	1/2	01	Prateleira Fixa   Estante fijo   Fixed Shelf	295x208x15
14	1/2	03	Prateleira   Estante   Shelf	295x208x15
15	1/2	01	Lateral Direita Nicho   Nicho del lado derecho   Right Side Niche	1470x295x15
16	2/2	04	Fundo   Fondo   Bottom	934x370x3
17	1/2	01	Fundo Menor   Fondo Menor   Minor Fund	1494x235x3
18	2/2	01	Porta de Vidro   Puerta de vidrio   Glass door	1490x598x20

Ferragens | Herrajes | Hardware

<b>A</b>	03x	<b>B</b>	44x	<b>C</b>	36x	<b>D</b>	02x	<b>E</b>	88x
									
Parafuso 5,0x50mm FLA. Tornillo 5,0x50mm FLA. Screw 5,0x50mm FLA.		Parafuso 3,5x40mm CHT. Tornillo 3,5x40mm CHT. Screw 3,5x40mm CHT.		Parafuso 3,5x14mm FLA. Tornillo 3,5x14mm FLA. Screw 3,5x14mm FLA.		Parafuso 3,5x12mm CHT. Tornillo 3,5x12mm CHT. Screw 3,5x12mm CHT.		Cavilha 8x25mm Cinta 8x25mm Dowel 8x25mm	
<b>F</b>	116x	<b>G</b>	24x	<b>H</b>	03x	<b>I</b>	03x	<b>J</b>	03x
									
Prego 10x10mm Clavo 10x10mm Nail 10x10mm		Fixador de fundos Fijador de fondos Bottom fixer		Suporte de fixação Soporte de fijación Mounting bracket		Bucha plástica 8mm Bucha de plástico 8mm 8mm plastic bushing		Proteção para cantoneira Ángulo de protección Protection angle	
<b>K</b>	04x	<b>L</b>	04x	<b>M</b>	01x	<b>N</b>	03x	<b>O</b>	02x
									
Calço Removível Calzado extraíble Removable Shim		Dobradilha SlideOn Alta Amort. 35mm Bisagra SlideOn Alta Amort. 35mm Hinge SlideOn High damper 35mm		Perfil Puxador 2015 - 150mm Perfil de Tirador 2015 - 150mm Profile Handle 2015 - 150mm		Cantoneira plástica Cantoneira plástica Plastic angle brackets		Sachê de cola Bolsa de pegamento Glue bag	
<b>P</b>	02x	<b>Q</b>	22x	<b>R</b>	04x	<b>S</b>	01x		
									
Giz de correção Tiza de corrección Chalk of correction		Adesivo tapan parafuso 10mm Adhesivo tapón de tornillo 10mm Bolt cover adhesive 10mm		Parafuso União 30mm Tornillo Unión 30mm Union Screw 30mm		Etiqueta resinada Henn Etiqueta resinada Henn Henn resin label			

O parafuso (R) deve ser usada somente quando este módulo for acoplado a outro módulo componível Henn.

El tornillo (R) se debe utilizar sólo cuando el módulo está conectado a otro módulo componible Henn.

The screw (R) should be used only when this module is attached to another Henn modular module.

RECOMENDAÇÃO

Para fixar o móvel na parede usar o suporte de fixação (H), o parafuso 3,5x14mm FLA (C), a Bucha 8mm (I) e o parafuso 5,0x50mm FLA (A).

RECOMENDACIÓN

Para conectar el móvil a la pared con el soporte (H), tornillo 3,5 x14mm FLA (C), el casquillo de 8 mm (I) y el 5,0 x50mm tornillo FLA (A).

RECOMMENDATION

To fix the furniture to the wall use the fixing bracket (H), the 3.5x14mm FLA (C) screw, the 8mm bushing (I) and the 5.0x50mm FLA (A).