

Torre Quente 1 Forno Americana | Torre caliente 1 Horno Americana | Hot Tower 1 Oven Americana C350-05 Branco HP

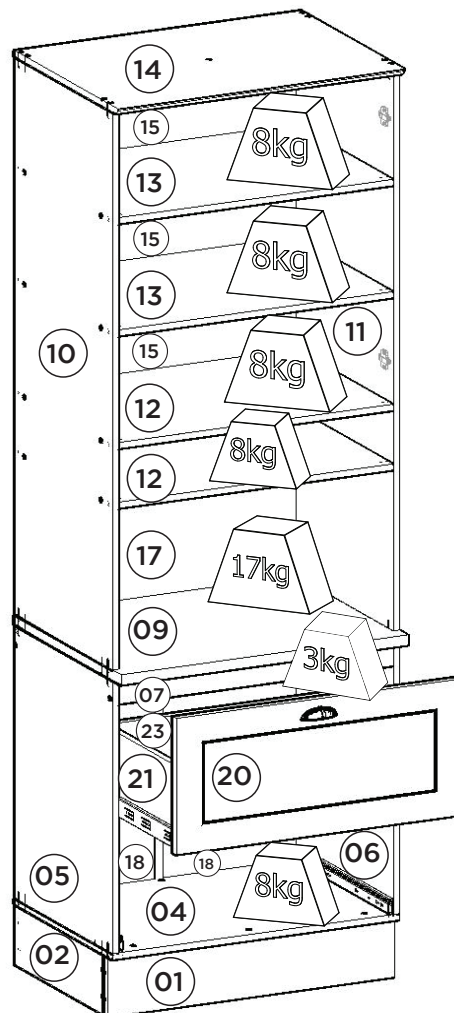

Pesos máximos recomendados com carga distribuída
Peso máximo recomendado con la carga distribuída
Recommended maximum weights with evenly distributed.

Requisitos para montagem Requisitor para la montaje Assembly Requirements

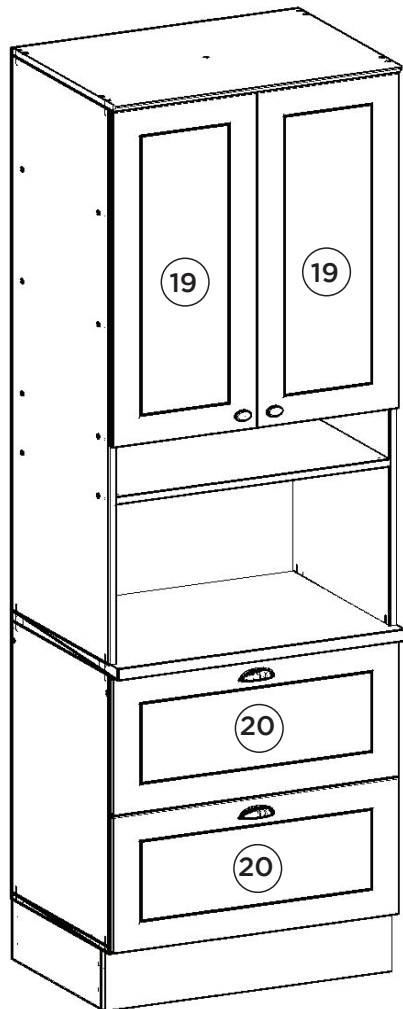
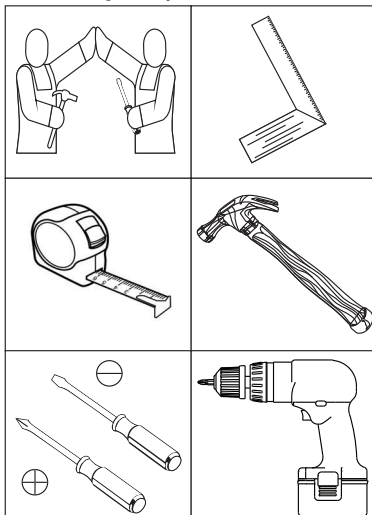

Imagens meramente ilustrativas
Imágenes meramente ilustrativas
Images for illustration only

AVISO

Para limpeza de seu móvel, use uma flanela seca ou umedecida, e não utilize produtos químicos que possam danificar seu produto.

SISTEMA DE MONTAGEM

O sistema de montagem dos produtos, funciona de acordo com a ordem crescente dos números indicados no desenho. Ex: 01, 02, 03, 04... até a conclusão da montagem.

ADVERTENCIA

Para limpieza de su móvil, use una flanela seca o húmeda, y no utilice productos químicos que puedan dañar su producto.

SISTEMA DE MONTAJE

El sistema de montaje de los productos funciona de acuerdo con el orden creciente de los números indicados en el dibujo. Ej.: 01, 02, 03, 04... hasta la conclusión del montaje.

NOTICE

To clean your furniture, use a dry or wet cloth, and do not use chemicals that may damage your product.

ASSEMBLY SYSTEM

The products' assembly system works according to the increasing order of the indicated numbers. For example: 01, 02, 03, 04 ... to the end of the assembly.

1º

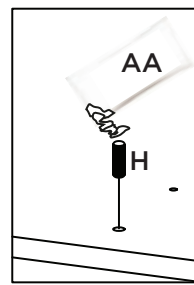
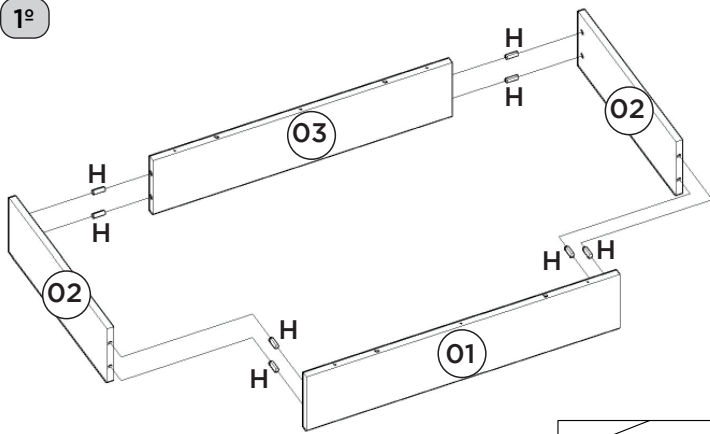

Utilizar o sachê de cola (AA) em todas as cavilhas (H) do produto.

Con el pegamento sobre (AA) en todos los pernos (H) producto.

Use the glue sachet (AA) on all the pegs (H) of the product.

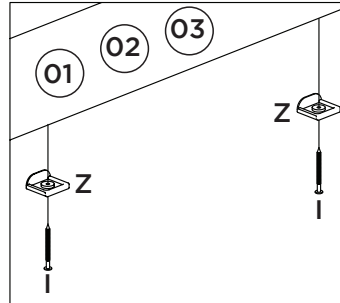
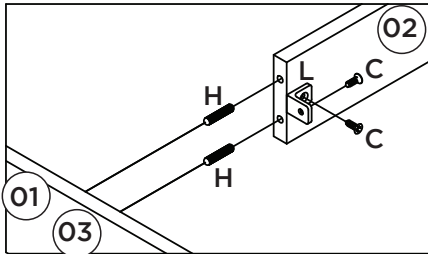
**OPCIONAL:**

O944-121 Kit Pé Cônico 145mm (vendido separadamente). Caso opte em colocar pé no produto, utilizar as pré-furações que possui na Base e fixá-lo com o Parafuso que consta no Kit.

OPCIONAL:

O944-121 Kit Pie Cónico 145mm (se vende por separado). Si opta por colocar pie en el producto, utilizar las pre-huracuras que tenga en la Base y fijarlo con el Tornillo que consta en el Kit.

OPTIONAL:

O944-121 Tapered Foot Kit 145mm (sold separately). If you choose to put foot in the product, use the pre-drillings in the Base and fix it with the Screw included in the Kit.

2º

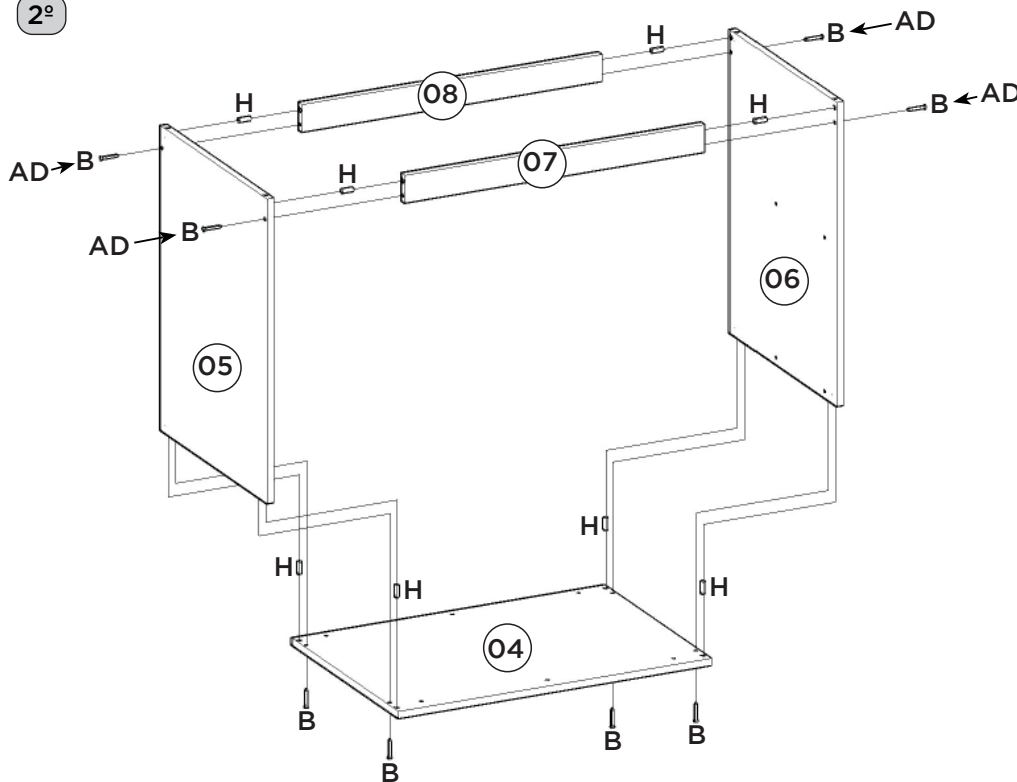

3º

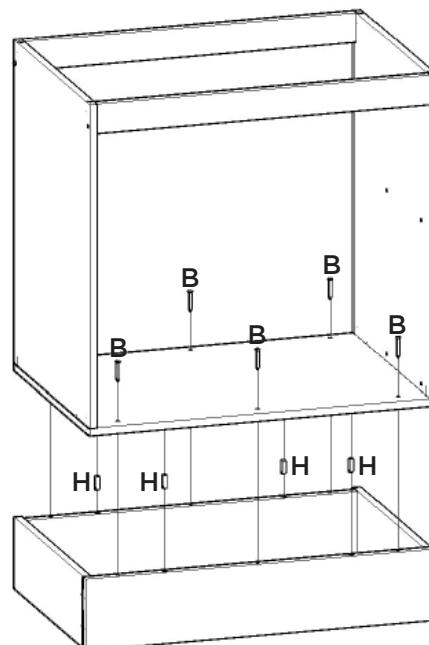

4°

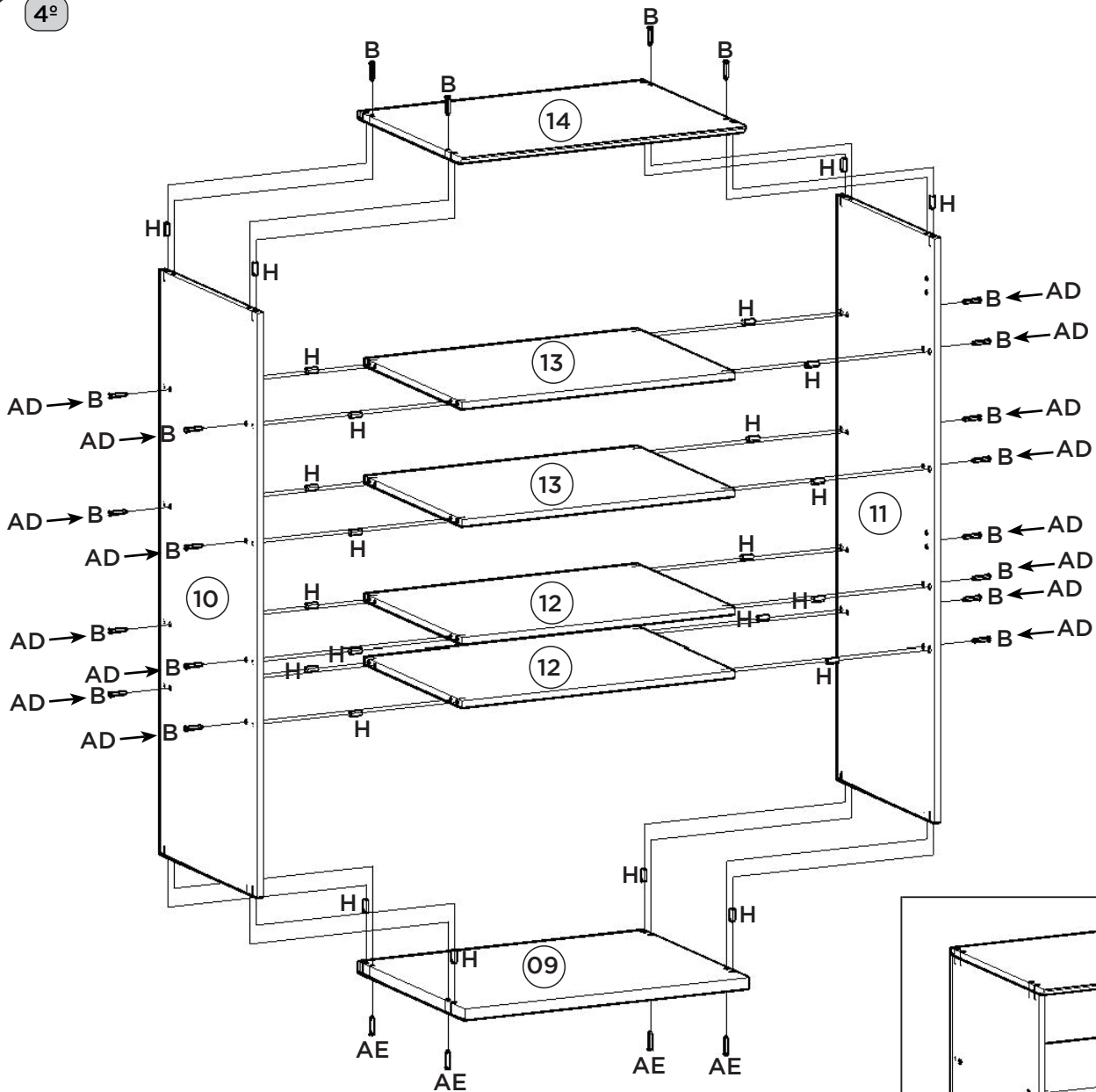

5°

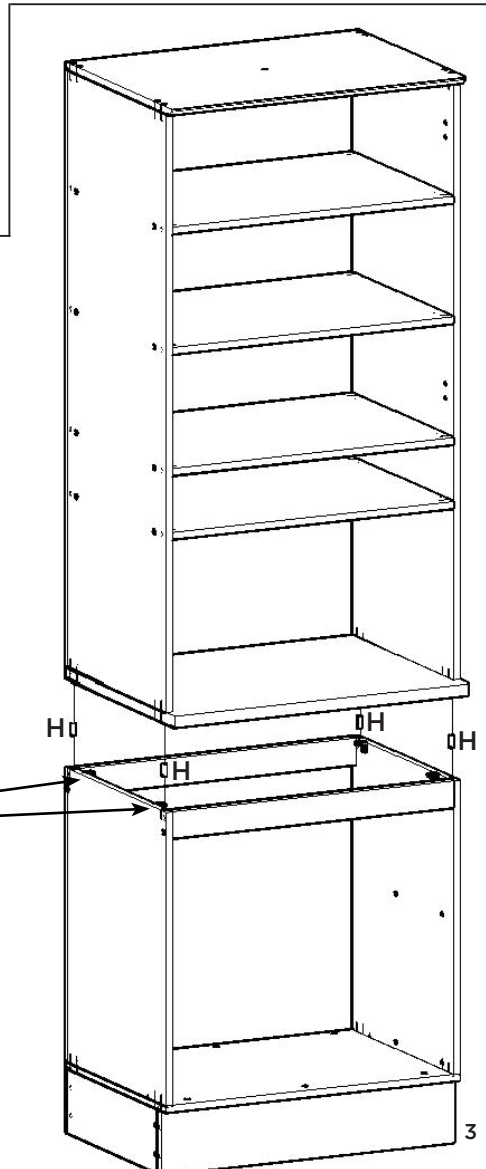
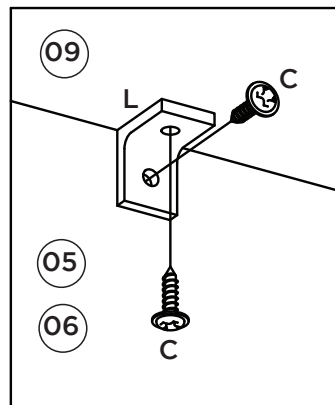

ATENÇÃO: Por questão de segurança, recomendamos a não utilização do Fundo (17) caso o espaço seja utilizado por forno elétrico ou forno embutido, dessa forma, haverá melhor propagação do calor, evitando danos em seu móvel.

ADVERTENCIA: Por razones de seguridad, se recomienda no utilizar el Fondo (17) si el espacio es utilizado por horno eléctrico o una función de horno, de esta manera no será mejor propagación del calor, evitando el daño a su móvil.

ATTENTION: For safety reasons, we recommend not using the Fund (17) if the space is used by an electric oven or built-in oven, in this way, there will be better propagation of the heat, avoiding damage to your furniture.

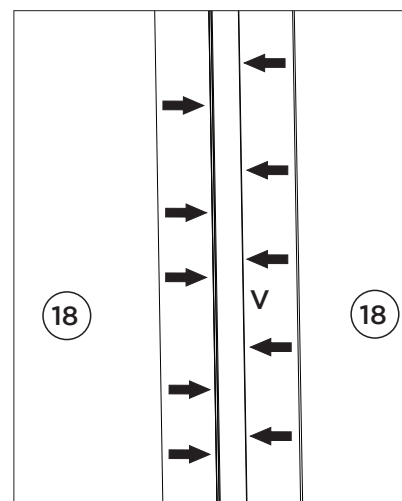
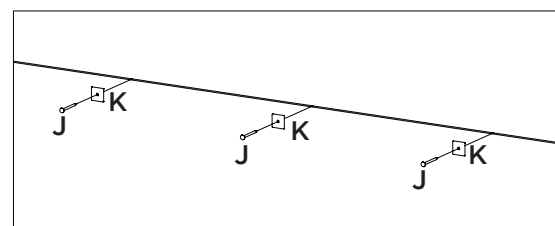
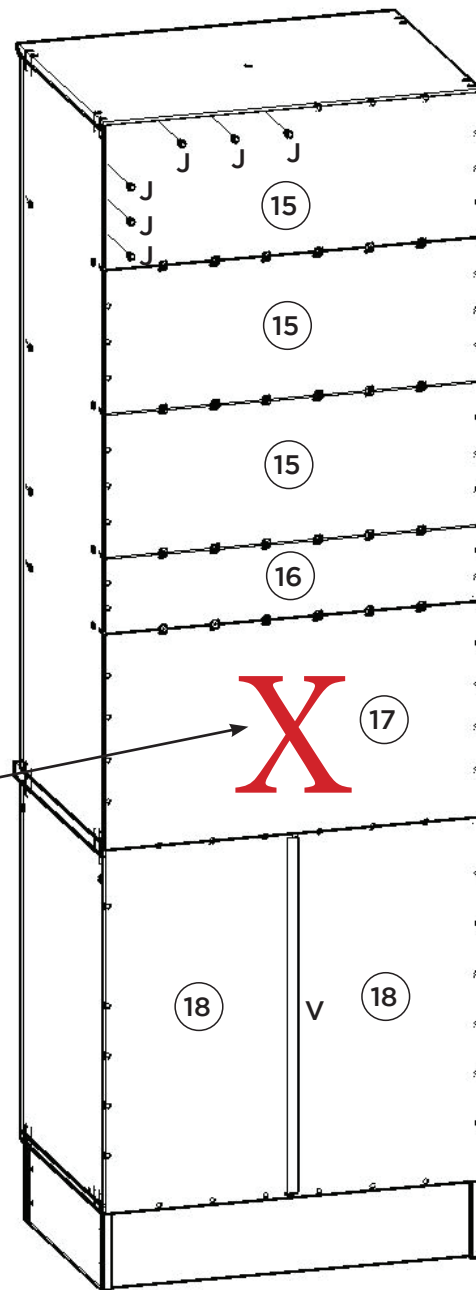

Opção Suspensa

Opción suspendida

Suspended Option

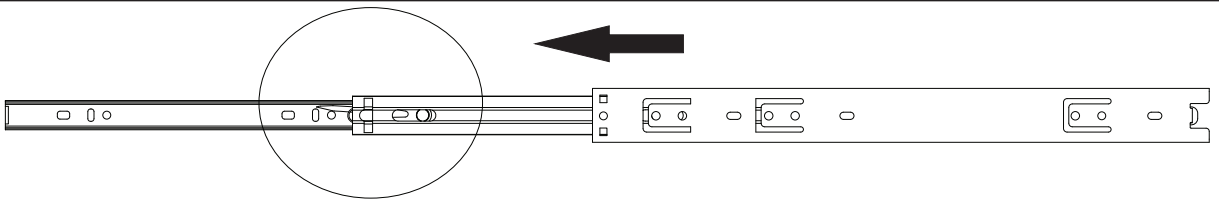
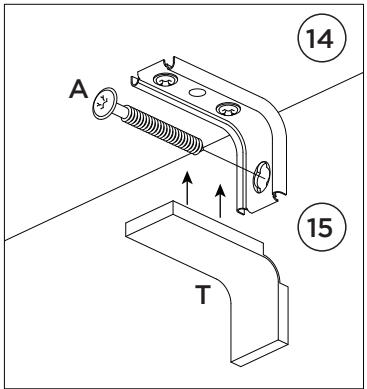
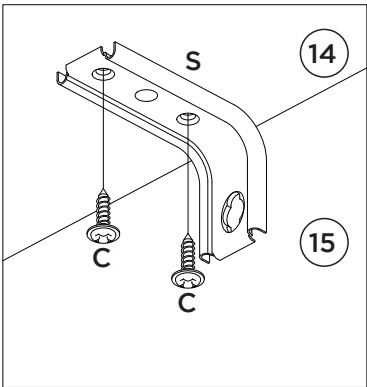
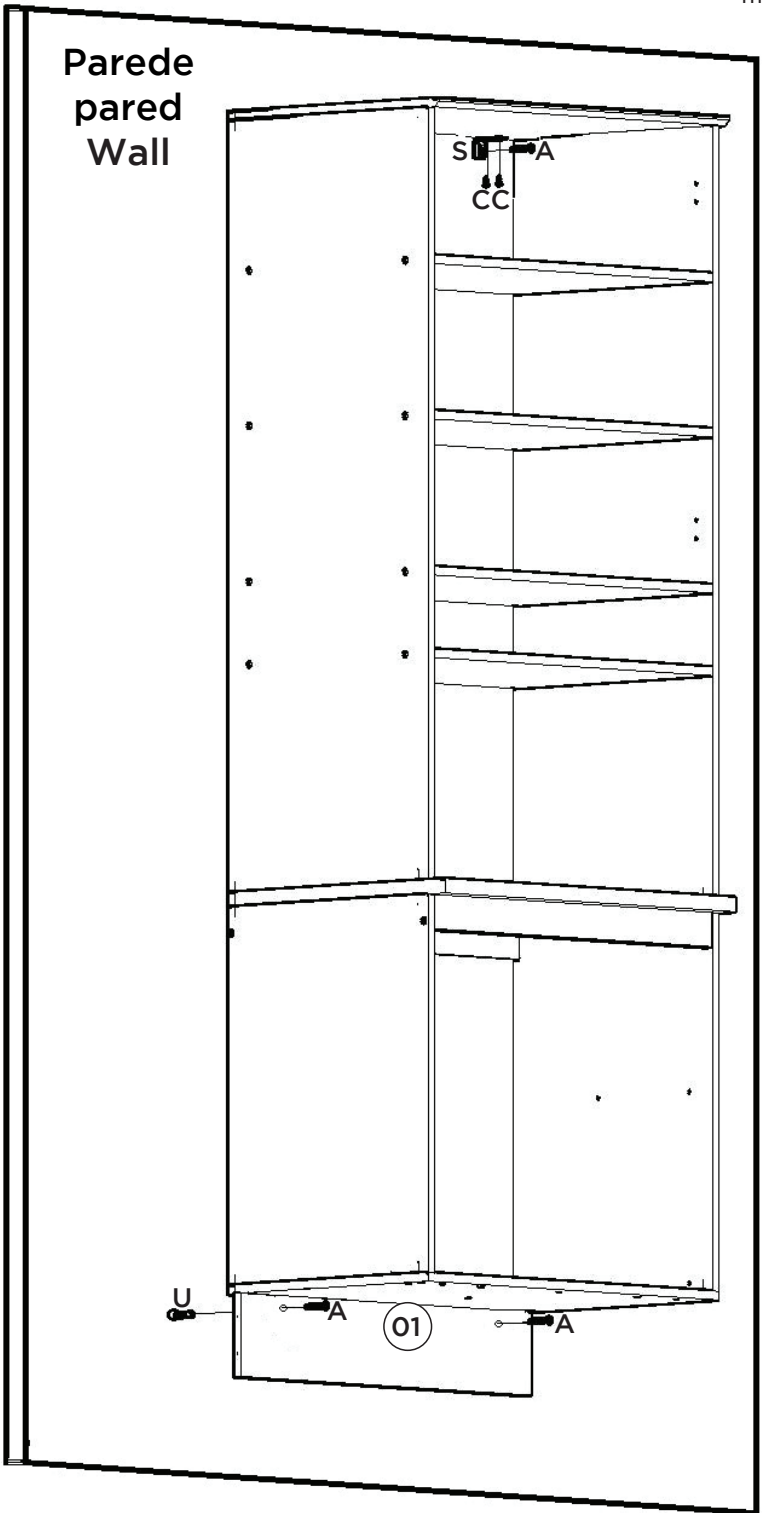

Para a desmontagem da corredeira siga a instrução ao lado.

Para el desmontaje seguimiento de diapositivas la instrucción siguiente a.

For the dismount of the sliding onem follows the instruction aside.

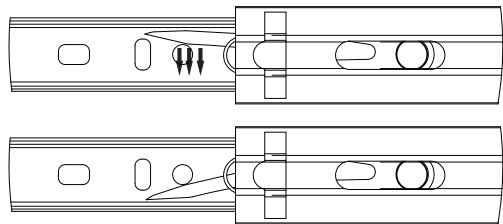

Fixar as corredeiras nessas furações
 Fijar las diapositivas de estos agujeros
 Fix slides in these drillings

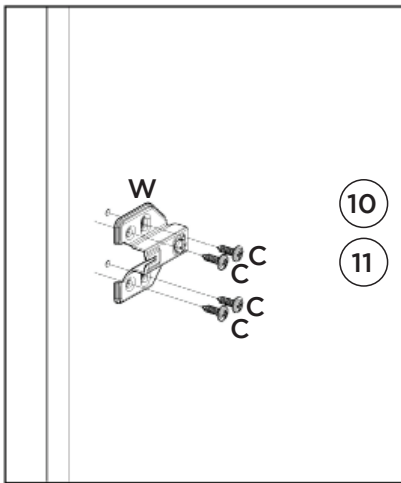

10

11

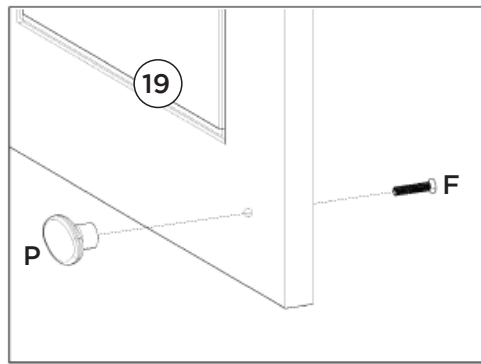

19

Para colocação dos puxadores, é necessário fazer a furação passante, com Broca de 5mm.

Para la colocación de las asas, es necesario perforar a través, con una broca de 5mm.

To place the handles is necessary to make the through hole, drill 5mm.

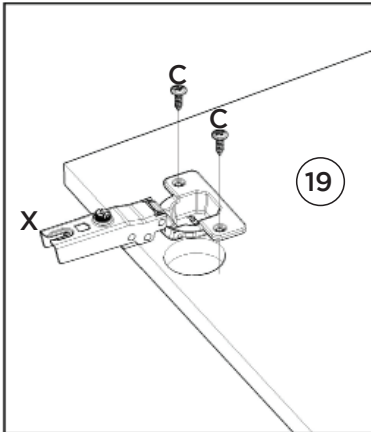

19

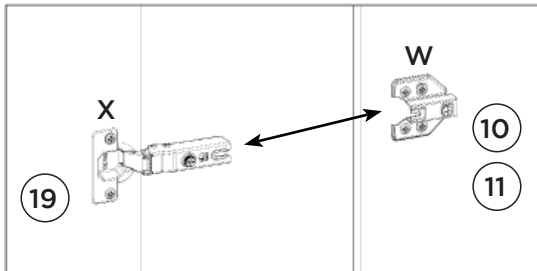

19

10

11

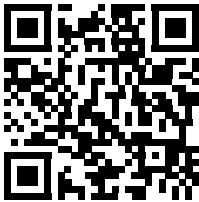

Vídeo: Instalar e regular Dobradiças

Vídeo: Instale y ajuste las bisagras

Vídeo: Install and adjust hinges

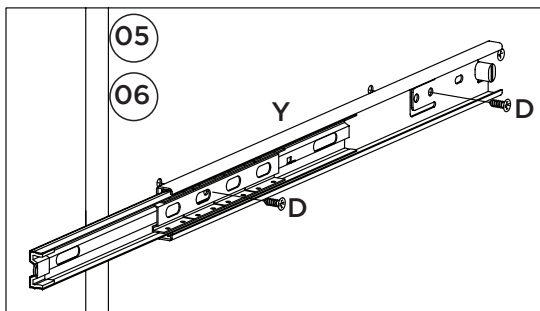

05

06

Y

D

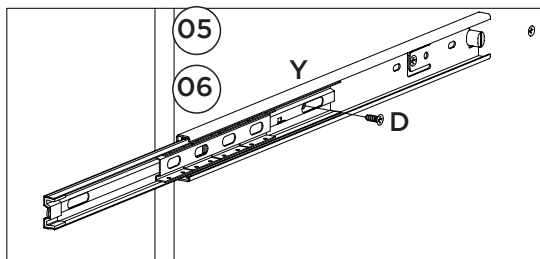

05

06

Y

D

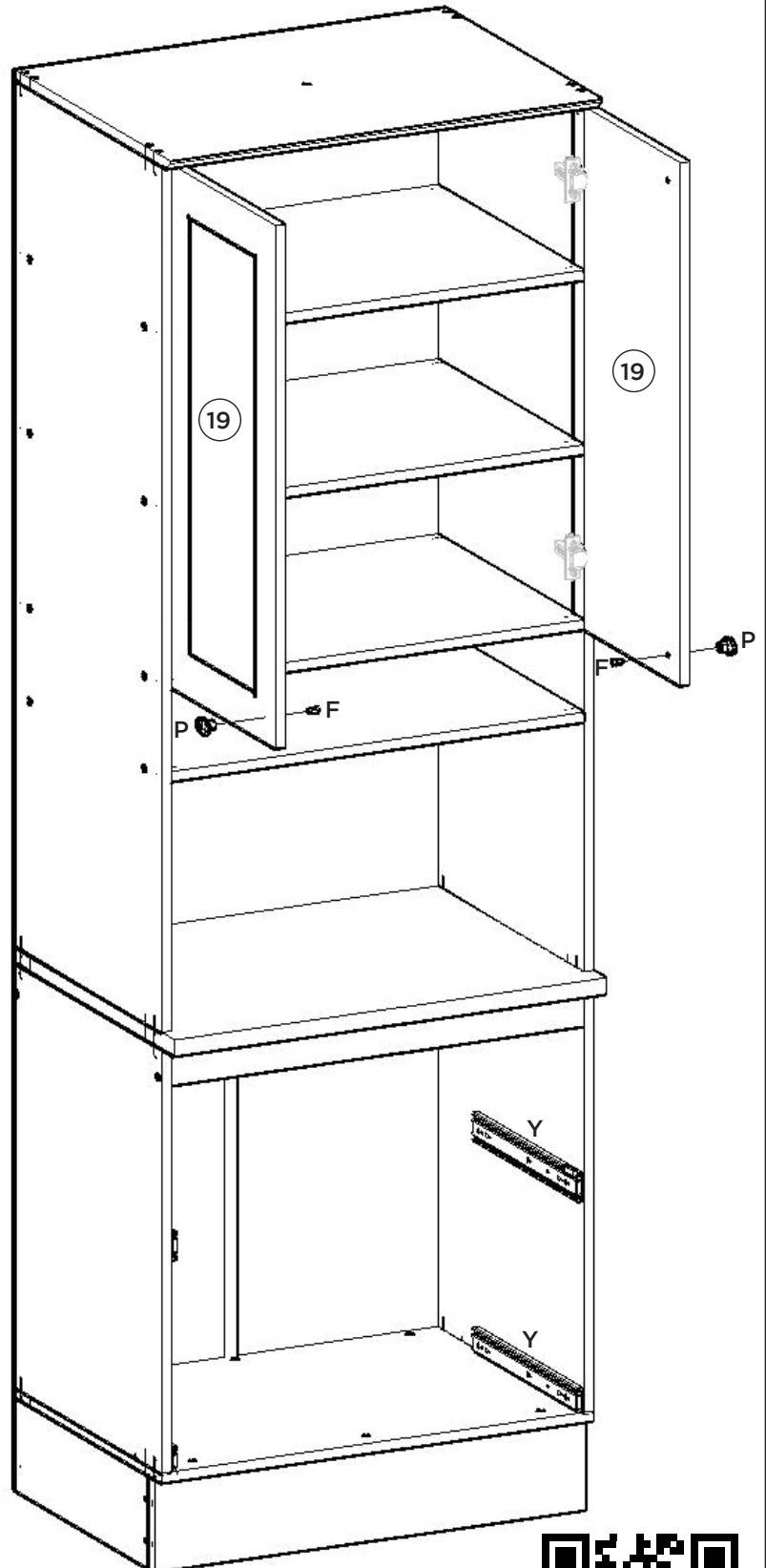

19

19

P

F

P

Y

Y

Vídeo: Dicas para fixar a Corrediça

Vídeo: Consejos para arreglar la diapositiva

Vídeo: Tips for Fixing the Slide



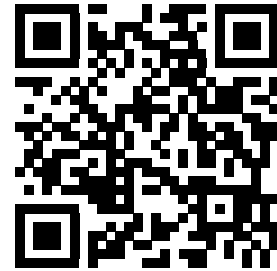
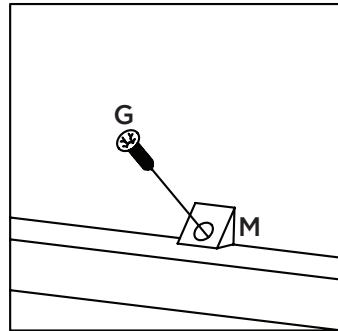
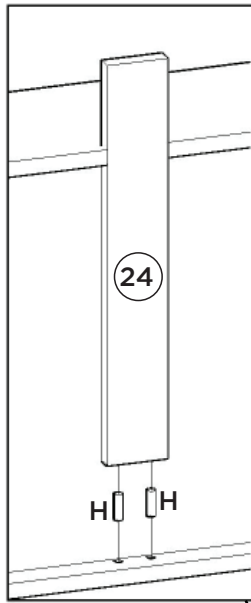
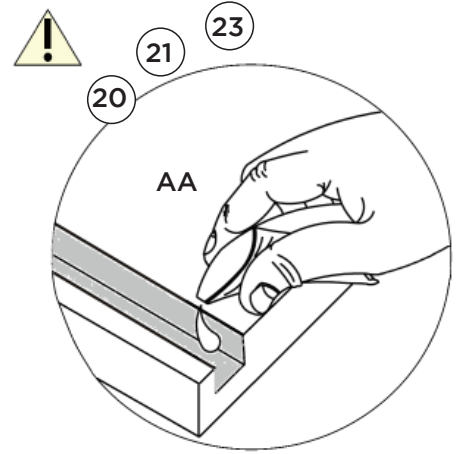
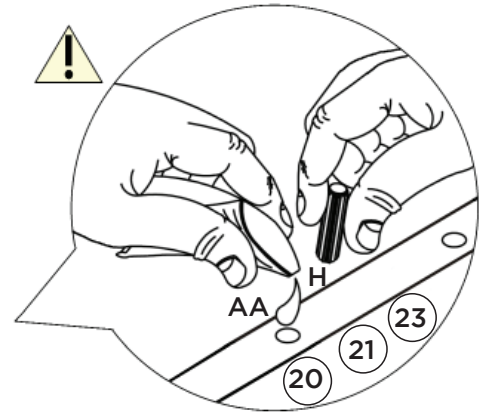
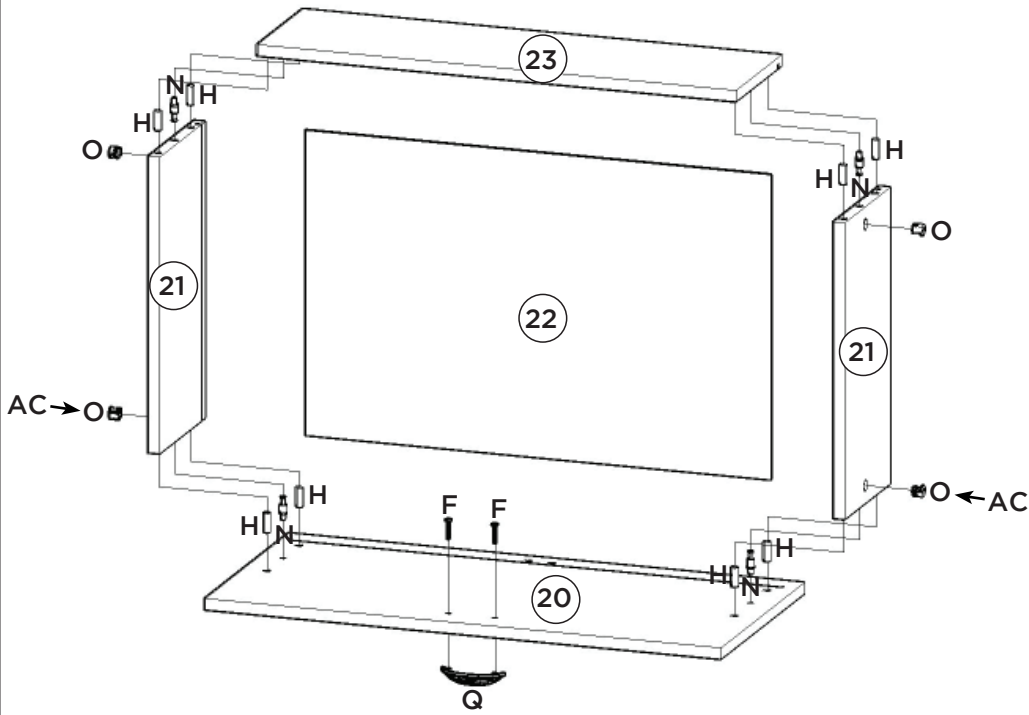



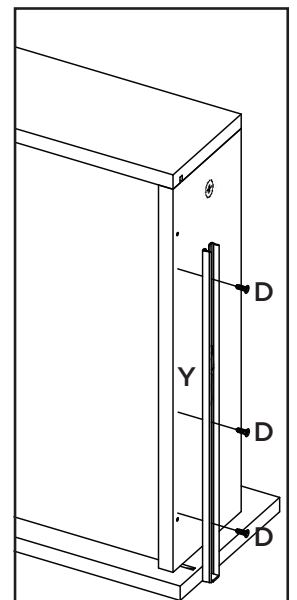
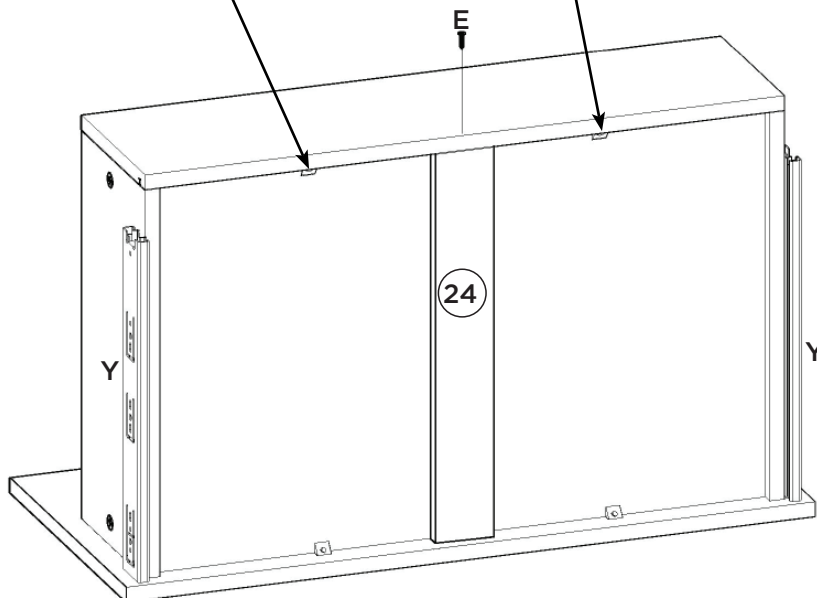







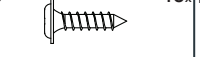

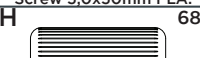
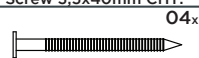
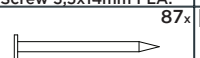
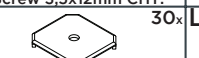

- Video: Dicas para fixar o Minifix
- Video: Consejos para arreglar Minifix
- Video: Tips for Fixing Minifix

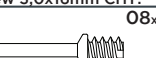
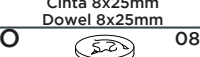

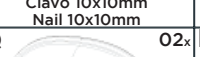
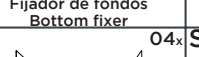
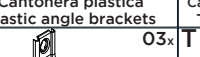
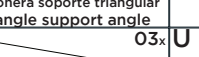
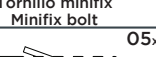
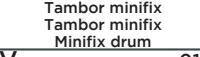
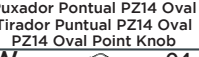
| Item | Caixa Caja Box | Qtd Ctd Qty | Descrição Descripción Description | Medidas (mm) Dimensions (mm) Size (measurements) (mm) |
|------|----------------------|-------------------|---|---|
| 01 | 1/2 | 01 | Rodapé Frontal Frente pie de página Front Footer | 715x145x15 |
| 02 | 2/2 | 02 | Rodapé Lateral Pie de página Side Side Footer | 450x145x15 |
| 03 | 1/2 | 01 | Rodapé Traseiro Pie de página trasera Rear Footer | 683x145x15 |
| 04 | 2/2 | 01 | Base Base Base | 715x490x15 |
| 05 | 1/2 | 01 | Lateral Esquerda Inferior Lateral Izquierda Inferior Left Side Lower | 660x490x15 |
| 06 | 1/2 | 01 | Lateral Direita Inferior Lateral Derecha Inferior Right Side Bottom | 660x490x15 |
| 07 | 1/2 | 01 | Travessa frontal Travesaño frontal Front crossbar | 684x60x15 |
| 08 | 1/2 | 01 | Travessa traseira Travesaño trasero Rear bumper | 684x60x15 |
| 09 | 2/2 | 01 | Tampo 25mm Tapa 25mm 25mm Top | 715x533x25 |
| 10 | 1/2 | 01 | Lateral Esquerda Superior Lateral Izquierda Superior Upper Left Side | 1345x490x15 |
| 11 | 1/2 | 01 | Lateral Direita Superior Lateral Derecha Superior Right Side Superior | 1345x490x15 |
| 12 | 2/2 | 02 | Prateleira Central Estantería central Central Shelf | 684x490x15 |
| 13 | 1/2 | 02 | Prateleira Superior Estantería Superior Upper Shelf | 684x490x15 |
| 14 | 2/2 | 01 | Tampo Tapa Top | 715x517x15 |
| 15 | 2/2 | 03 | Fundo Superior Fondo superior Superior background | 708x272x3 |
| 16 | 2/2 | 01 | Fundo Estreito Fondo Estrecho Narrow Bottom | 708x143x3 |
| 17 | 2/2 | 01 | Fundo central Fondo central Central fund | 708x405x3 |
| 18 | 2/2 | 02 | Fundo Cru Fondo Crudo Raw Background | 687x353x3 |
| 19 | 1/2 | 02 | Porta Puerta Door | 813x354x15 |
| 20 | 1/2 | 02 | Frente de gaveta Frente de cajón Front of drawer | 711x330x15 |
| 21 | 2/2 | 04 | Lado de Gaveta Lado del cajón Drawer Side | 400x180x15 |
| 22 | 1/2 | 02 | Fundo de gaveta Fondo de cajón Bottom of drawer | 640x411x3 |
| 23 | 2/2 | 02 | Ripa de trás Malla detrás Rear lath | 659x180x15 |
| 24 | 2/2 | 02 | Ripa Estrutural Gaveta Ripa Estructural Cajón Drawer Structural Clamp | 400x60x15 |

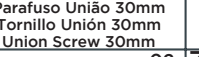
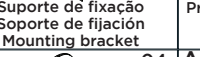
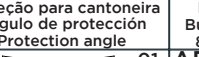
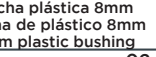
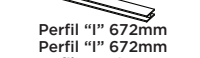
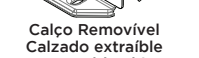
Ferragens | Herrajes | Hardware

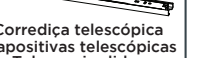
| | | | | | | |
|---|--|--|---|---|--|--|
| A 05x  Parafuso 5,0x50mm FLA. Tornillo 5,0x50mm FLA. Screw 5,0x50mm FLA. | B 34x  Parafuso 3,5x40mm CHT. Tornillo 3,5x40mm CHT. Screw 3,5x40mm CHT. | C 46x  Parafuso 3,5x14mm FLA. Tornillo 3,5x14mm FLA. Screw 3,5x14mm FLA. | D 24x  Parafuso 3,5x12mm CHT. Tornillo 3,5x12mm CHT. Screw 3,5x12mm CHT. | E 02x  Parafuso 3,0x30mm CHT. Tornillo 3,0x30mm CHT. Screw 3,0x30mm CHT. | F 06x  Parafuso 4x20mm CHT. ZB Tornillo 4x20mm CHT. ZB Screw 4x20mm CHT. ZB | G 08x  Parafuso 3,0x16mm CHT. Tornillo 3,0x16mm CHT. Screw 3,0x16mm CHT. |
| H 68x  Cavilha 8x25mm Cinta 8x25mm Dowel 8x25mm | I 04x  Prego 12x12mm Anelado Clavo 12x12mm Anillado Ringed Nails 12x12mm | J 87x  Prego 10x10mm Clavo 10x10mm Nail 10x10mm | K 30x  Fixador de fundos Fijador de fondos Bottom fixer | L 08x  Cantoneira plástica Cantonera plástica Plastic angle brackets | M 08x  Cantoneira suporte triangular Cantonera soporte triangular Triangle support angle | N 08x  Parafuso minifix Tornillo minifix Minifix bolt |
| O 08x  Tambor minifix Tambor minifix Minifix drum | P 02x  Puxador Pontual PZ14 Oval Tirador Pontual PZ14 Oval Oval Point Knob | Q 02x  Puxador Concha Tirador Concha Shell Handle | R 04x  Parafuso União 30mm Tornillo Unión 30mm Union Screw 30mm | S 03x  Suporte de fixação Soporte de fijación Mounting bracket | T 03x  Proteção para cantoneira Ángulo de protección Protection angle | U 05x  Buchta plástica 8mm Bucha de plástico 8mm 8mm plastic bushing |
| V 01x  Perfil "I" 672mm Perfil "I" 672mm | W 04x  Calço Removível Calzado extraíble Removable Shim | X 04x  Dobradica SlideOn Baixa Amortecedor 35mm Bisagra SlideOn Baja Amortiguador 35mm Low SlideOn Hinge 35mm Shock Absorber | Y 02x  Corredicea telescópica Diapositivas telescópicas Telescopic slides | Z 04x  Sapata "L" 16x20mm Zapata "L" 16x20mm "L" shoe 16x20mm | AA 01x  Sachê de cola Bolsa de pegamento Glue bag | AB 02x  Giz de correção Tiza de corrección Chalk of correction |
| AC 04x  Adesivo tampa parafuso 17mm Adhesivo tapón de tornillo 17mm Bolt cover adhesive 17mm | AD 28x  Adesivo tampa parafuso 10mm Adhesivo tapón de tornillo 10mm Bolt cover adhesive 10mm | AE 04x  Parafuso 4,5x50mm CHT. Tornillo 4,5x50mm CHT. Screw 4,5x50mm CHT. | AF 01x  Etiqueta resinada Henn Etiqueta resinada Henn Henn resin label | | | |



O parafuso (R) deve ser usada somente quando este módulo for acoplado a outro módulo componível Henn.

RECOMENDAÇÃO

Para fixar o móvel na parede usar o suporte de fixação (S), o parafuso 3,5x14mm FLA (C), a Bucha 8mm (U) e o parafuso 5,0x50mm FLA (A).



El tornillo (R) se debe utilizar sólo cuando el módulo está conectado a otro módulo componible Henn.

RECOMENDACIÓN

Para conectar el móvil a la pared con el soporte (S), tornillo 3,5 x14mm FLA (C), el casquillo de 8 mm (U) y el 5,0 x50mm tornillo FLA (A).



The screw (R) should be used only when this module is attached to another Henn modular module.

RECOMMENDATION

To fix the furniture to the wall use the mounting bracket (S), the 3.5x14mm FLA (C) screw, the 8mm bushing (U) and the 5.0x50mm FLA (A).