

Balcão Pia 02 Portas 03 Gavetas Essência

Fregadero 02 Puertas 03 Cajones Essência | Counter Sink 02 Doors 03 Drawers Essência

C558-133 Areia HP

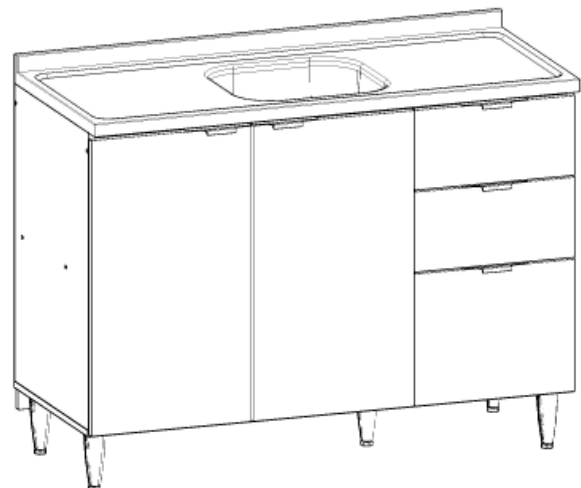
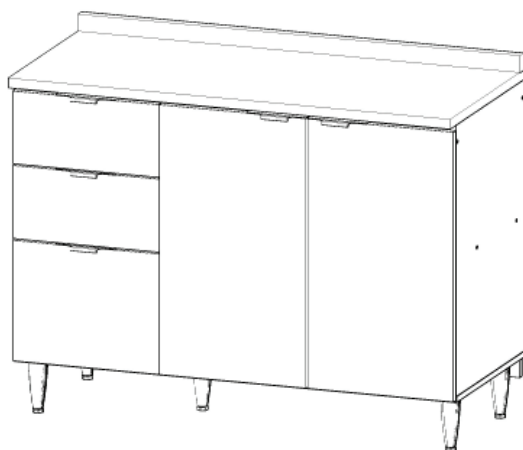
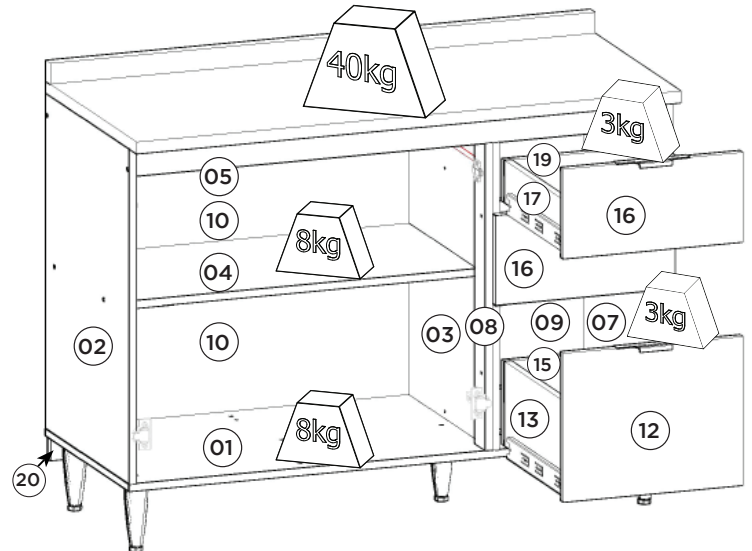
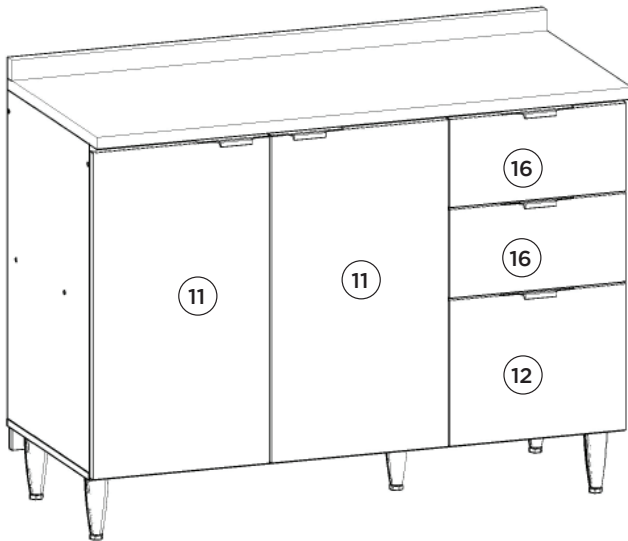

Pesos maximos recomendados com carga distribuida
Peso máximo recomendado con la carga distribuida
Recommended maximum weights with evenly distributed.

Requisitos para montagem Requisitor para la montaje Assembly Requirements

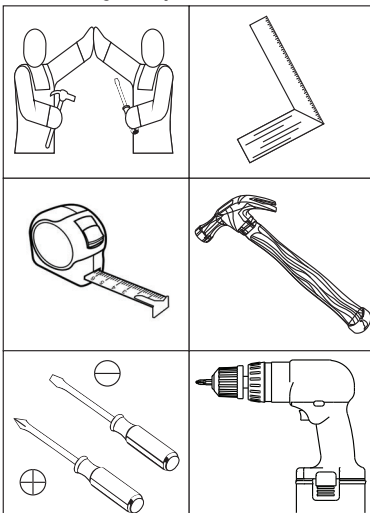

Imagens meramente ilustrativas
Imágenes meramente ilustrativas
Images for illustration only

AVISO

Para limpeza de seu móvel, use uma flanela seca ou umedecida, e não utilize produtos químicos que possam danificar seu produto.

SISTEMA DE MONTAGEM

O sistema de montagem dos produtos, funciona de acordo com a ordem crescente dos números indicados no desenho. Ex: 01, 02, 03, 04... até a conclusão da montagem.

ADVERTENCIA

Para limpieza de su móvil, use una flanela seca o húmeda, y no utilice productos químicos que puedan dañar su producto.

SISTEMA DE MONTAJE

El sistema de montaje de los productos funciona de acuerdo con el orden creciente de los números indicados en el dibujo. Ej.: 01, 02, 03, 04... hasta la conclusión del montaje.

NOTICE

To clean your furniture, use a dry or wet cloth, and do not use chemicals that may damage your product.

ASSEMBLY SYSTEM

The products' assembly system works according to the increasing order of the indicated numbers. For example: 01, 02, 03, 04 ... to the end of the assembly.

1º

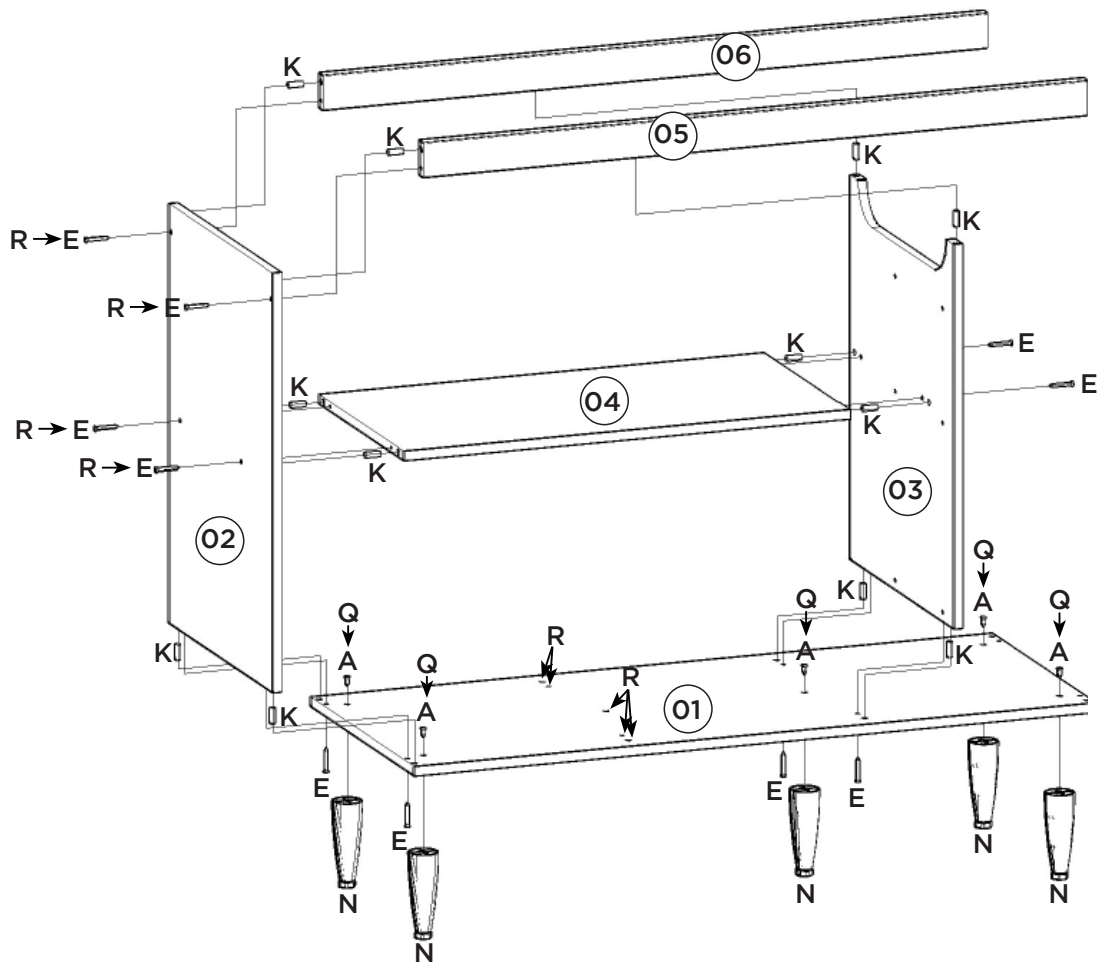

2º

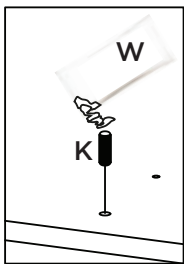

Utilizar o sachê de cola (W) em todas as cavilhas (K) do produto.

Con el pegamento sobre (W) en todos los pernos (K) producto.

Use the glue sachet (W) on all the pegs (K) of the product.

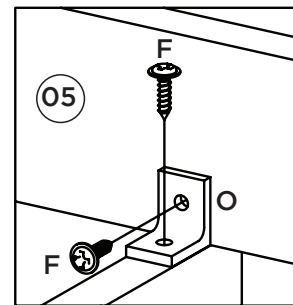

A pilastra da porta (08) deve estar alinhada com a divisão (03).

El pilar de la puerta (08) debe estar alineada con la división (03).

The door pillar (08) must be aligned with the partition (03).

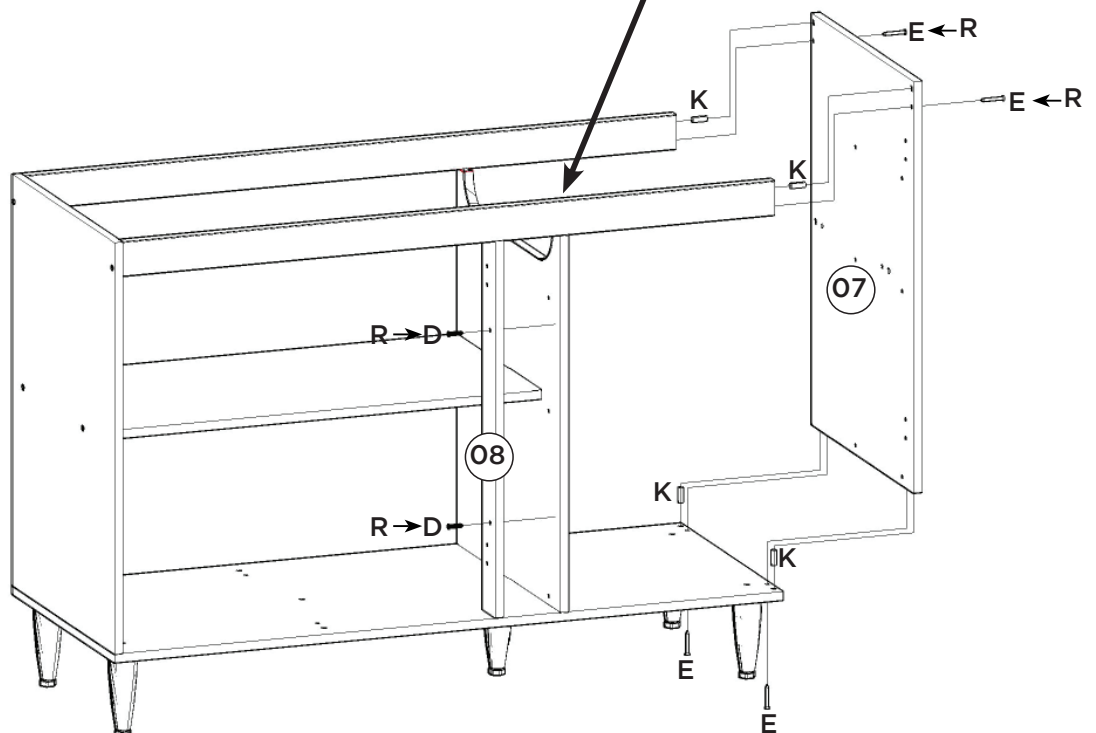

3º

Esse tampo é opcional e é vendido separadamente (C905-128).

Esta vez es opcional y se vende por separado (C905-128).

This top is optional and is sold separately (C905-128).

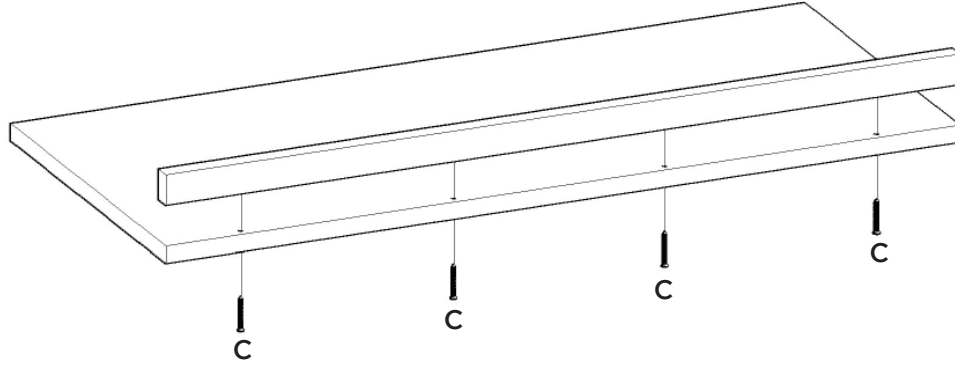

4º

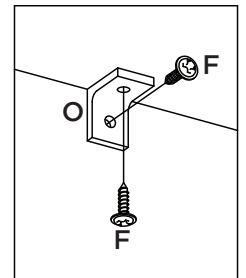
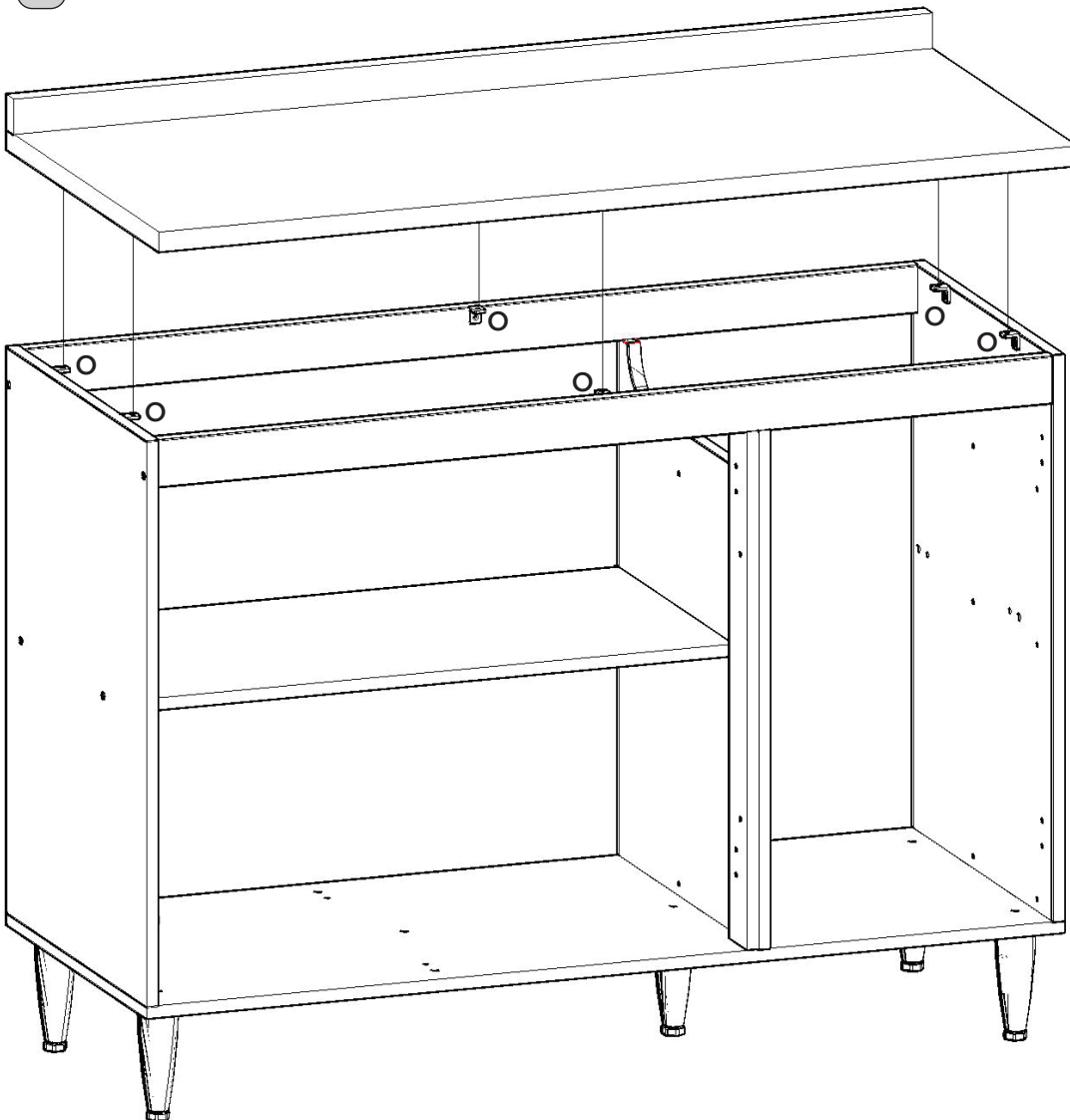

Caso o móvel seja montado com a opção do tampo, fixar o mesmo com 06 cantoneiras (O) e os parafusos 3,5x14mm (F).

Si se monta el auricular con la opción de la cubierta, fijarlo con Los ángulos 06 (O) y 3,5 x14mm tornillos (F).

If the furniture is to be installed with the top cover option, fix it with 06 (O) and 3.5x14mm screws (F).

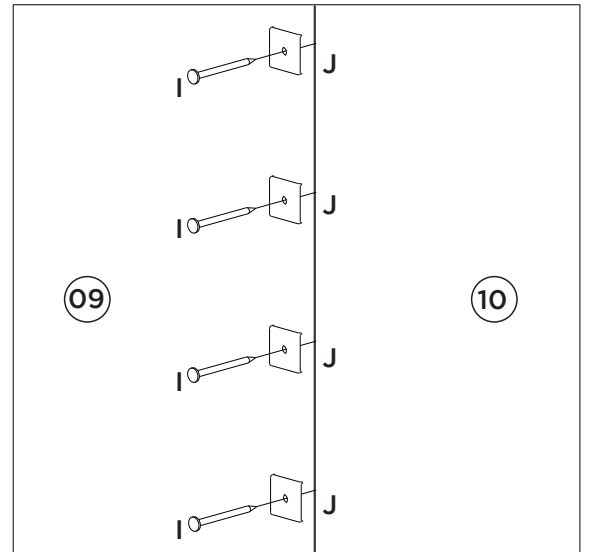
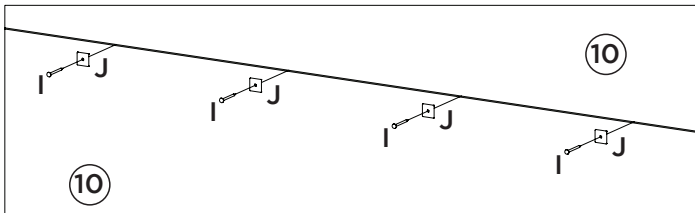
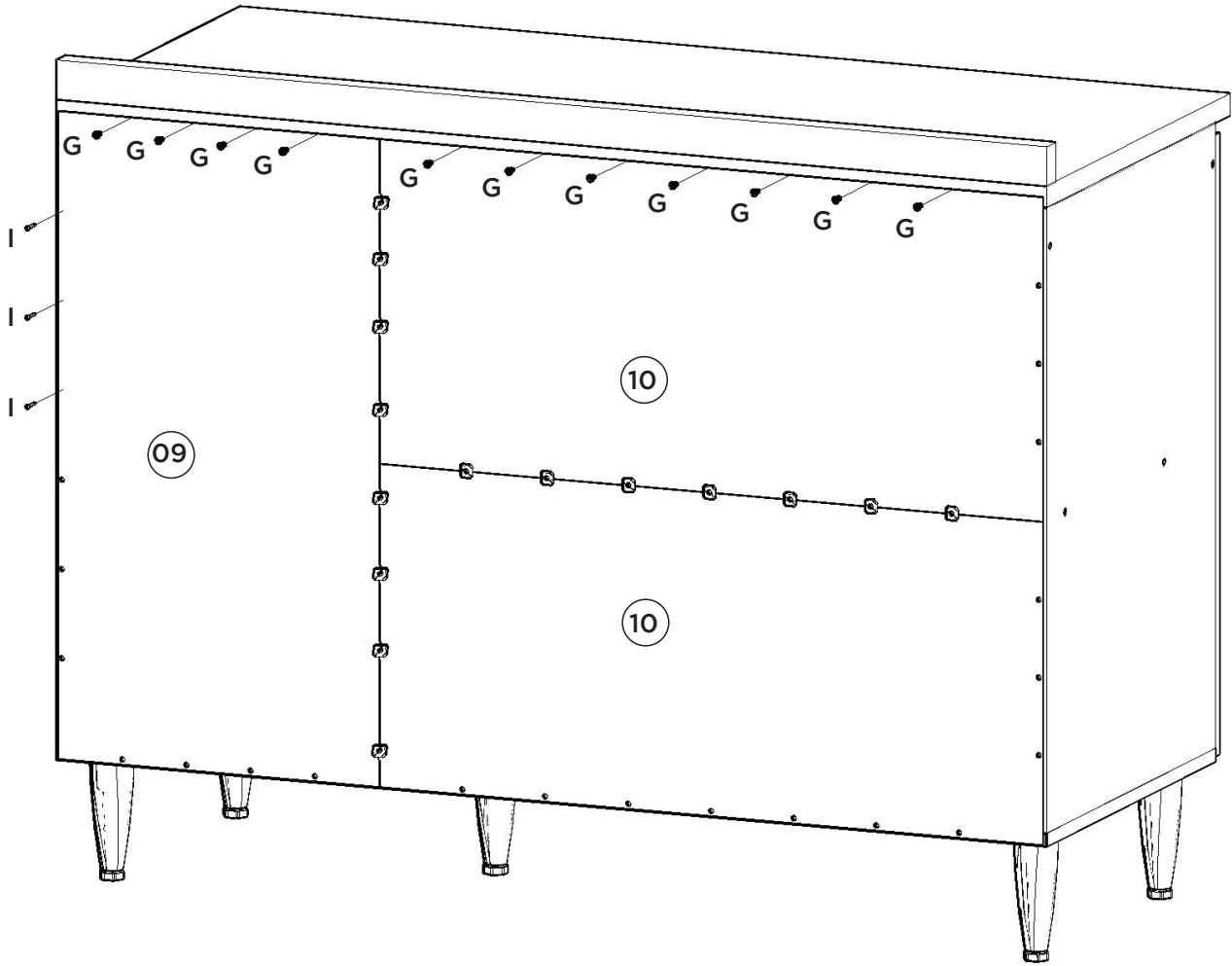

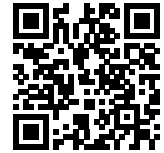
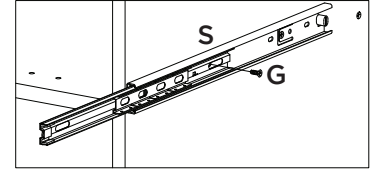
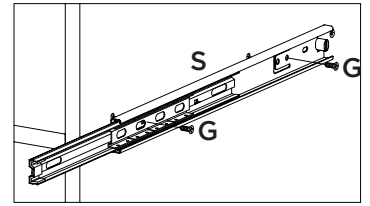
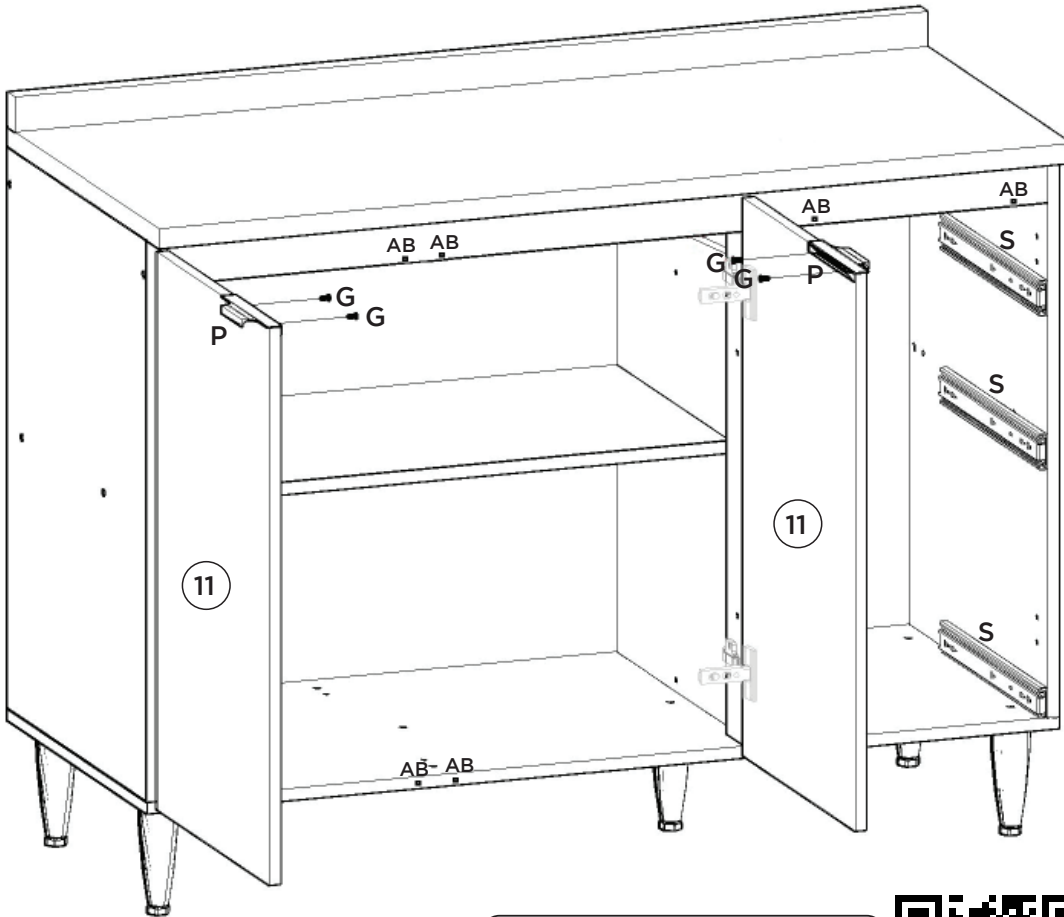

Vídeo: Dicas para fixar a Corrediça

Vídeo: Consejos para arreglar la diapositiva

Vídeo: Tips for Fixing the Slide

Vídeo: Instalar e regular Dobradiças

Vídeo: Instale y ajuste las bisagras

Vídeo: Install and adjust hinges

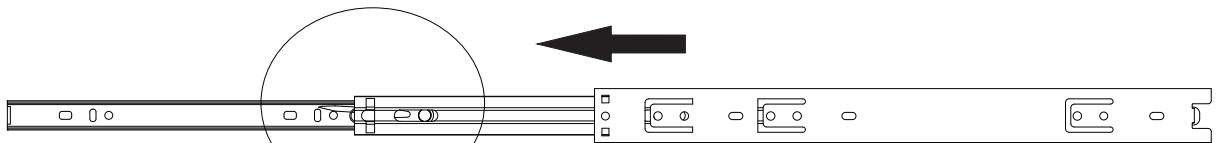
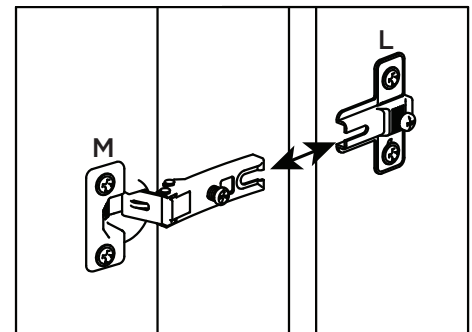
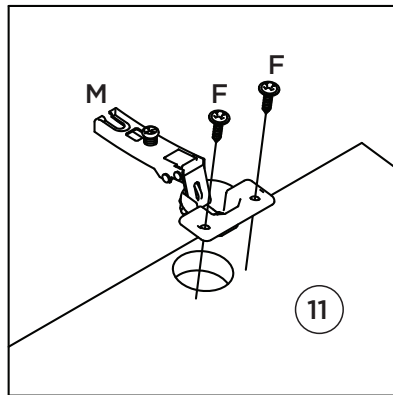
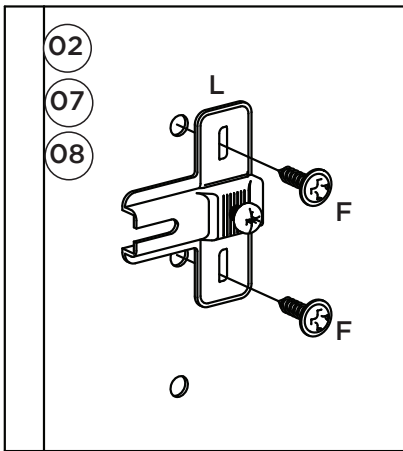
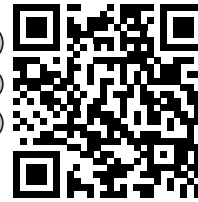

Para a desmontagem da corrediça siga a instrução ao lado.

Para el desmontaje seguimiento de diapositivas la instrucción siguiente a.

For the dismount of the sliding onem follows the instruction aside.

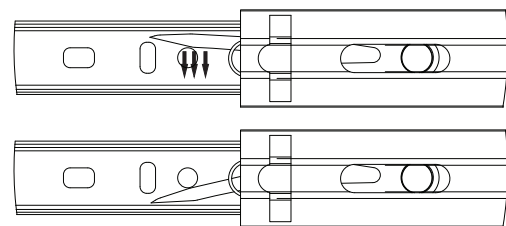

Fixar as corrediças nessas furações
 Fijar las diapositivas de estos agujeros
 Fix slides in these drillings

Parede
pared
Wall

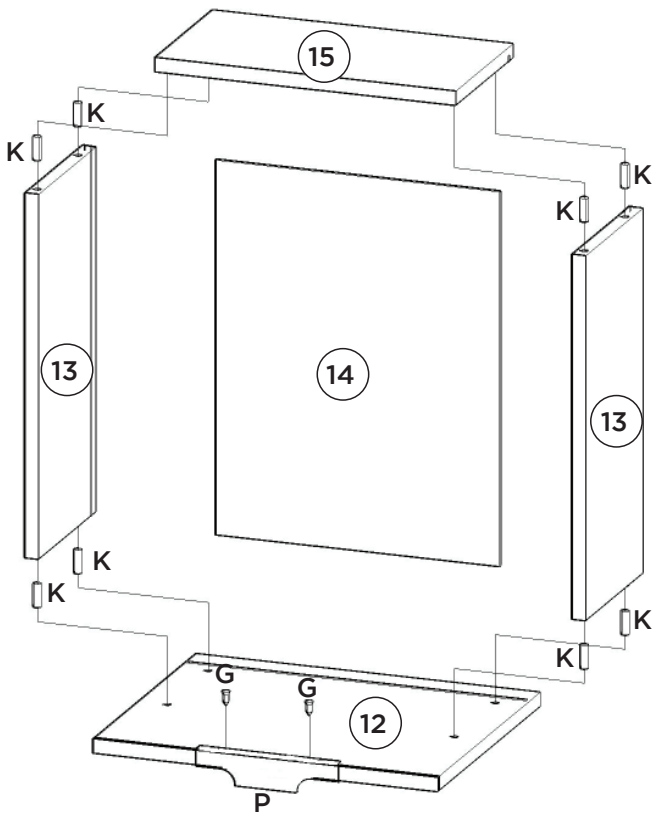
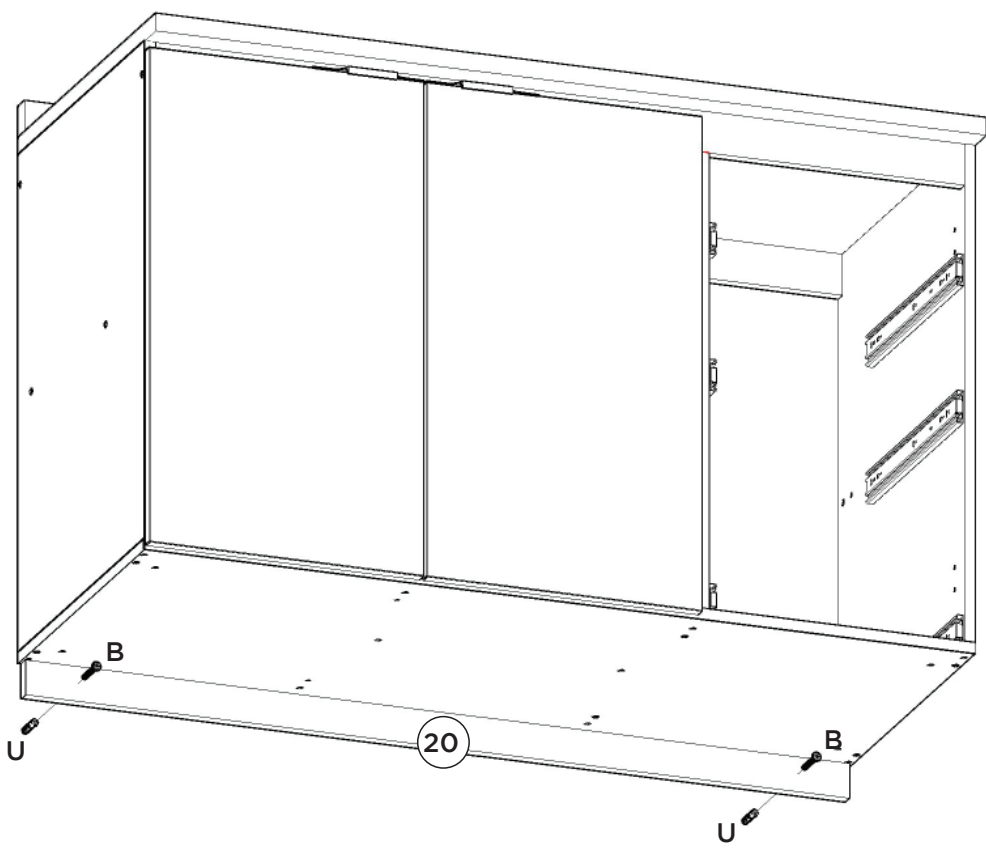

A corrediça (S) deverá ser alinhada com a parte de baixo do lado de gaveta (13).

La carcasa (S) será alineada con la parte de por el lado del cajón (13).

The slide (S) should be aligned with the underside of the drawer side (13).

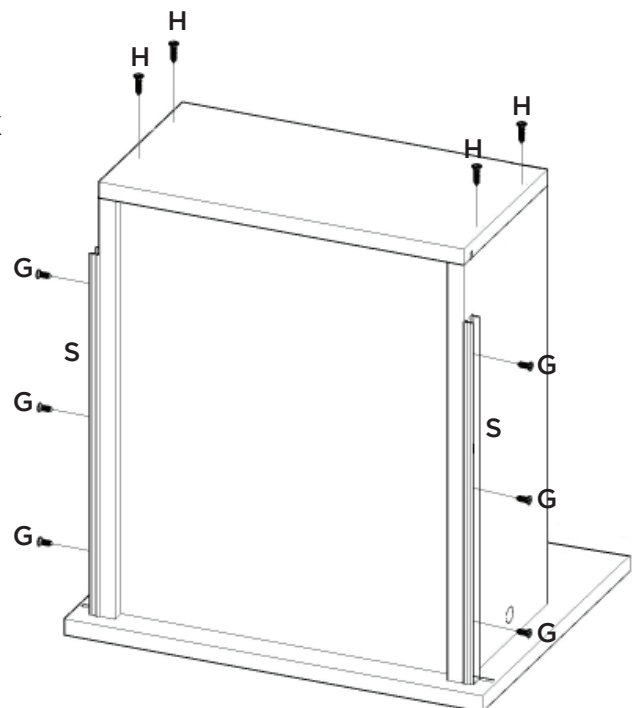
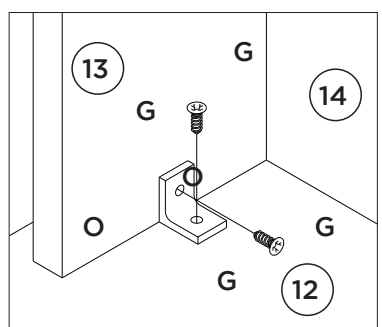

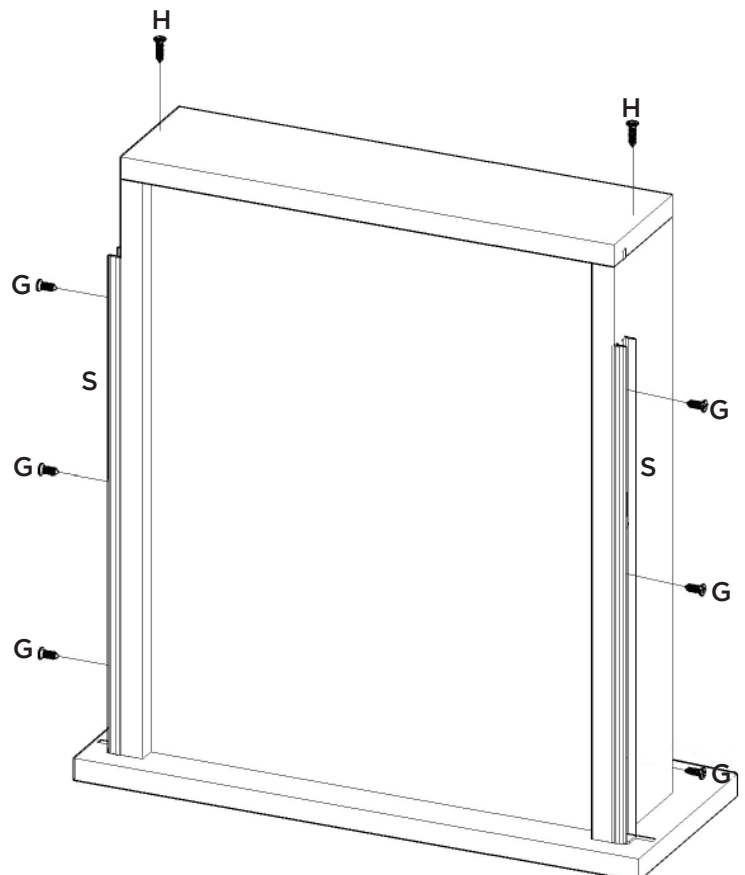
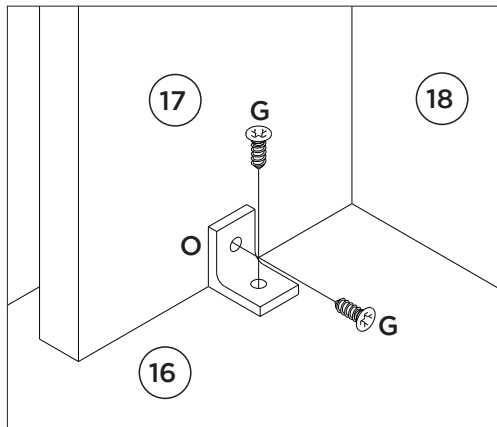
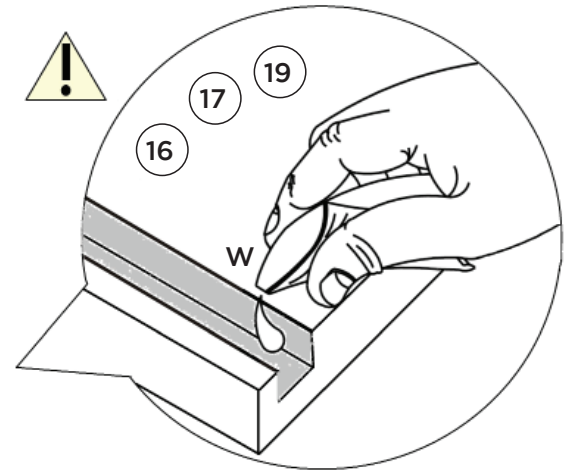
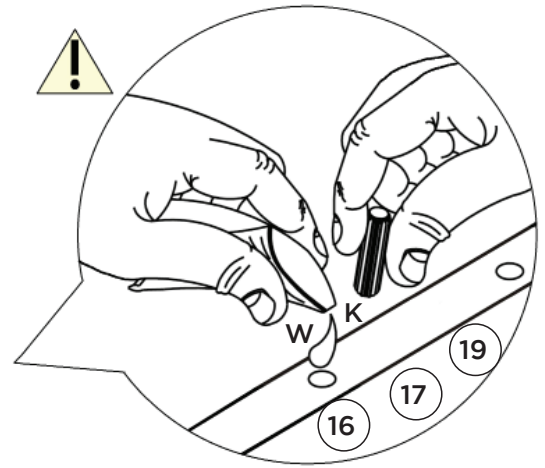
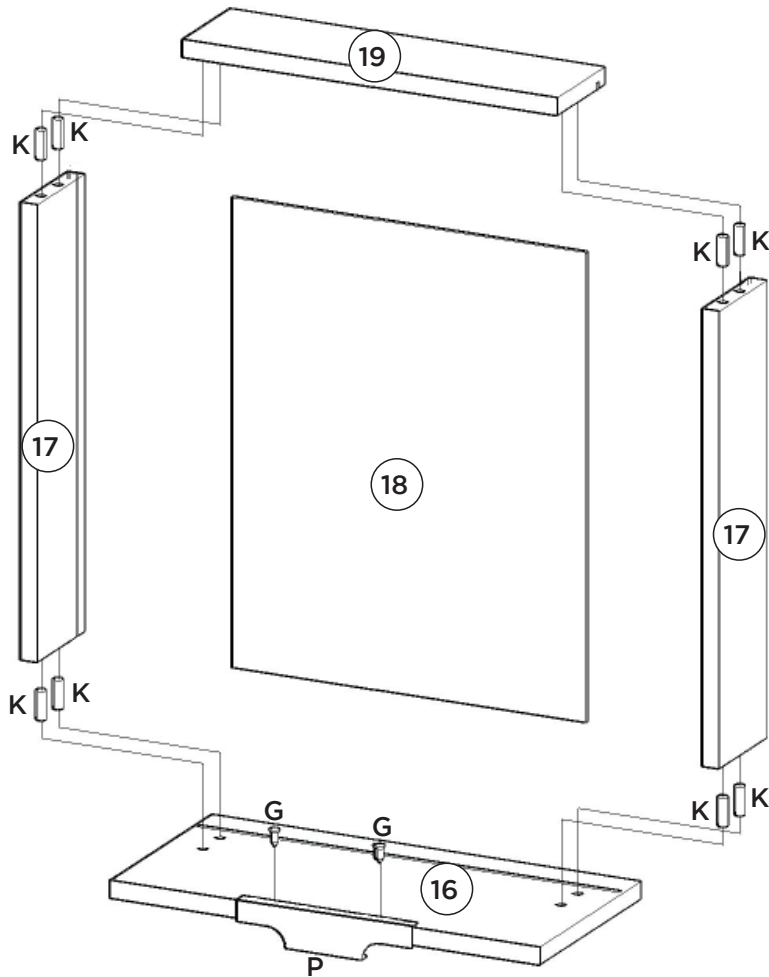











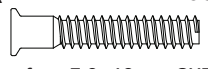
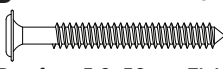

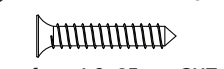
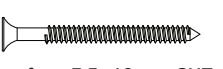

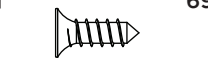

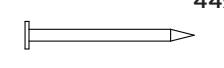
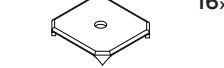





A correia (S) deverá ser alinhada com a parte de baixo do lado de gaveta (17).

La carcasa (S) será alineada con la parte de por el lado del cajón (17).

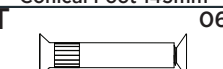
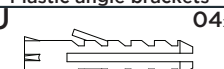
The slide (S) should be aligned with the underside of the drawer side (17).

Item	Caixa Caja Box	Qtd Ctd Qty	Descrição Descripción Description	Medidas (mm) Dimensions (mm) Size (measurements) (mm)
01	1/1	01	Base Base Base	1200x490x15
02	1/1	01	Lateral esquerda Lateral izquierda Left side	715x490x15
03	1/1	01	Divisão División Division	655x490x15
04	1/1	01	Prateleira Estante Shelf	784x400x15
05	1/1	01	Travessa frontal Travesaño frontal Front crossbar	1169x60x15
06	1/1	01	Travessa traseira Travesaño trasero Rear bumper	1169x60x15
07	1/1	01	Lateral direita Lateral derecha Right side	715x490x15
08	1/1	01	Pilastra da Porta Pilastra Puerta Pilaster door	654x60x15
09	1/1	01	Fundo menor Fondo menor Minor fund	727x389x3
10	1/1	02	Fundo maior Fondo mayor Greater Fund	803x363x3
11	1/1	02	Porta Puerta Door	710x396x15
12	1/1	01	Frente de Gaveta Maior Frente de cajón más grande Larger Drawer Front	396x318x15
13	1/1	02	Lado de gaveta Maior Lado del cajón más grande Larger drawer side	400x180x15
14=18	1/1	01	Fundo de gaveta Fondo de cajón Bottom of drawer	411x326x3
15	1/1	01	Ripa de Trás Maior Tablilla trasera más grande Larger rear clapboard	345x180x15
16	1/1	02	Frente de gaveta Frente de cajón Front of drawer	396x192x15
17	1/1	04	Lado de Gaveta Lado del cajón Drawer Side	400x90x15
18=14	1/1	02	Fundo de gaveta Fondo de cajón Bottom of drawer	411x326x3
19	1/1	02	Ripa de trás Malla detrás Rear lath	345x90x15
20	1/1	01	Travessa Sustentação Travessa Ayuda Support Travessa	1190x50x15

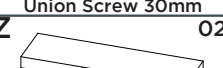
Ferragens | Herrajes | Hardware

A  Parafuso 7,0x40mm CHT. Tornillo 7,0x40mm CHT. Screw 7,0x40mm CHT.	B  Parafuso 5,0x50mm FLA. Tornillo 5,0x50mm FLA. Screw 5,0x50mm FLA.	C  Parafuso 4,5x50mm CHT. Tornillo 4,5x50mm CHT. Screw 4,5x50mm CHT.	D  Parafuso 4,0x25mm CHT. Tornillo 4,0x25mm CHT. Screw 4,0x25mm CHT.	E  Parafuso 3,5x40mm CHT. Tornillo 3,5x40mm CHT. Screw 3,5x40mm CHT.	F  Parafuso 3,5x14mm FLA. Tornillo 3,5x14mm FLA. Screw 3,5x14mm FLA.
G  Parafuso 3,5x12mm CHT. Tornillo 3,5x12mm CHT. Screw 3,5x12mm CHT.	H  Parafuso 3,0x30mm CHT. Tornillo 3,0x30mm CHT. Screw 3,0x30mm CHT.	I  Prego 10x10mm Clavo 10x10mm Nail 10x10mm	J  Fixador de fundos Fijador de fondos Bottom fixer	K  Cavilha 8x25mm Cinta 8x25mm Dowel 8x25mm	L  Calço metal alto 3mm Calzado metálico alto 3mm 3mm high metal chock
M  Dobradiça metal 35mm baixo Bisagras metálicas 35mm bajo Metal hinge 35mm low	N  Pé Cônico 145mm Pie Cónico 145mm Conical Foot 145mm	O  Cantoneira plástica Cantonera plástica Plastic angle brackets	P  Puxador PV392 160mm Tirador PV392 160mm PV392 Handle 160mm	Q  Adesivo tapa parafuso 17mm Adhesivo tapón de tornillo 17mm Bolt cover adhesive 17mm	R  Adesivo tapa parafuso 10mm Adhesivo tapón de tornillo 10mm Bolt cover adhesive 10mm
S  Corrediza telescópica Diapositivas telescópicas Telescopic slides	T  Parafuso União 30mm Tornillo Unión 30mm Union Screw 30mm	U  Bucha plástica 8mm Bucha de plástico 8mm 8mm plastic bushing	V  Divisor talheres 398x313mm Divisor cubiertos 398x313mm Cutlery divider 398x313mm	W  Sachê de cola Bolsa de pegamento Glue bag	X  Giz de correção Tiza de corrección Chalk of correction
Y  Suporte de fixação Soporte de fijación Mounting bracket	Z  Proteção para cantoneira Ángulo de protección Protection angle	AA  Etiqueta resinada Henn Etiqueta resinada Henn Henn resin label	AB  Batente PVC para Porta Parada de PVC para Puerta PVC Door Stop		



O parafuso (T) deve ser usada somente quando este módulo for acoplado a outro módulo componível Henn.

RECOMENDAÇÃO

Para fixar o móvel na parede usar o suporte de fixação (Y), o parafuso 3,5x14mm FLA (F), a Bucha 8mm (U) e o parafuso 5,0x50mm FLA (B).



El tornillo (T) se debe utilizar sólo cuando el módulo está conectado a otro módulo componible Henn.

RECOMENDACIÓN

Para conectar el móvil a la pared con el soporte (Y), tornillo 3,5 x14mm FLA (F), el casquillo de 8 mm (U) y el 5,0 x50mm tornillo FLA (B).



The screw (T) should be used only when this module is attached to another Henn modular module.

RECOMMENDATION

To fix the furniture to the wall use the mounting bracket (Y), the 3.5x14mm FLA (F) screw, the 8mm bushing (U) and the 5.0x50mm FLA (B).