

MONTAGEM DO PRODUTO / PRODUCT ASSEMBLY / MONTAJE DEL PRODUCTO

PASSO / STEP / PASO 8

Fixe as longarinas Nº 14 utilizando pregos 12 x 12 'D'.

Fix the pieces Nº 14 using 'D'.

Fije las piezas Nº 14 utilizando 'D'.

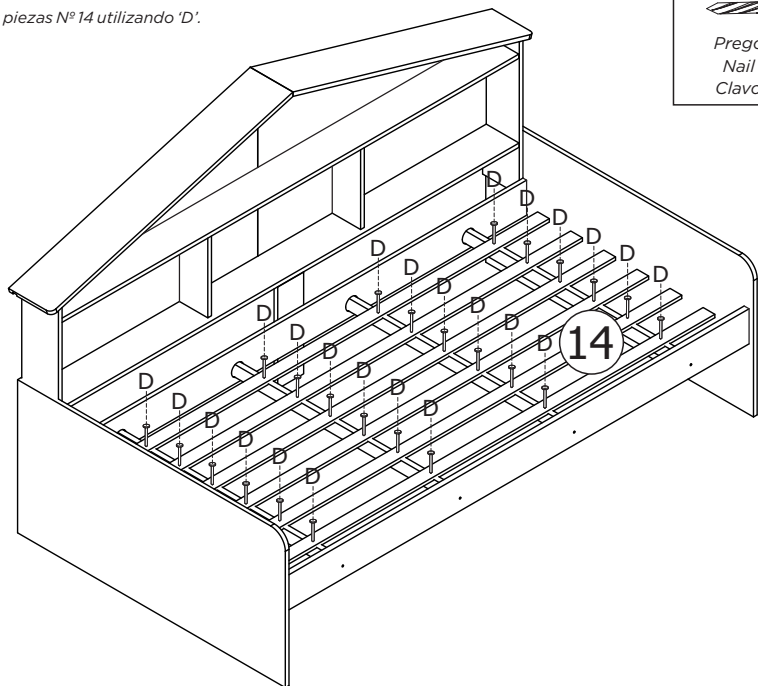
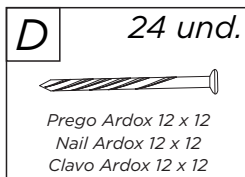

VISTA FRONTAL INVERTIDA
INVERTED FRON VIEW
VISTA FRONTAL INVERTIDA

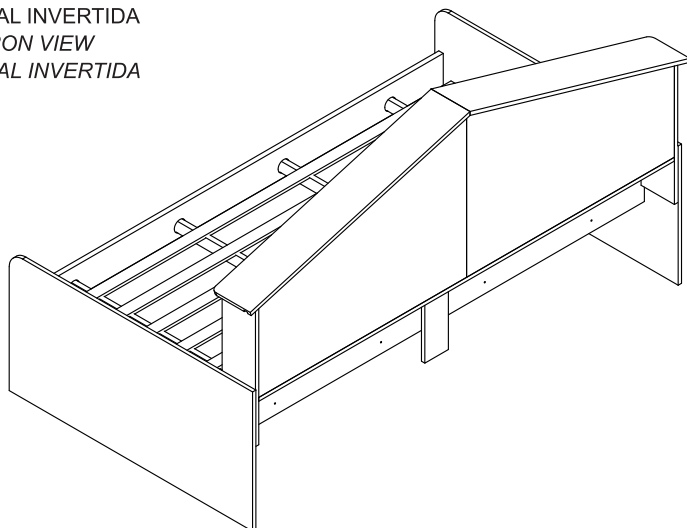

CAMA CASA DE BONECAS DIVERSAO - 8A
CASA DE BONECAS DIVERSÃO 8A BED
CAMA CASA DE BONECAS DIVERSAO - 8A

INSTRUÇÕES DE MONTAGEM
Assembly Instructions
Instrucciones de Montaje



Avenida Maracanã, 4.244 - Parque Industrial
Arapongas - PR - CEP: 86703-000
Assistência: 0800 645 2200
atendimento@puramagia.com.br
www.puramagia.com.br



facebook.com/puramagiamoveis



www.youtube.com/user/PuraMagiaMoveis



"Imagens meramente ilustrativas, sujeitas a alterações sem aviso prévio"
 "Image merely illustrative, subject to change without prior notice"
 "Imágenes ilustrativas, pueden ser cambiadas sin aviso previo"



PRODUTO: CAMA CASA DE BONECA DIVERSÃO - 8A

PRODUCT: CASA DE BONECA DIVERSÃO 8A BED

PRODUCTO: CAMA CASA DE BONECA DIVERSÃO - 8A



ATENÇÃO

Esta embalagem contém peças pequenas, mantenha afastada de crianças até que o produto esteja totalmente montado.
 Montagem requisitada para adultos!
 Utilizar parafusadeira com cabeça Phillips!
 As instruções são genéricas, as figuras podem variar!
 Mantenha todas as peças e componentes longe do alcance das crianças

ATTENTION

This package contains small parts, keep away from children until the product is fully assembled.
 Must be assembled by an adult!
 Use screwdriver with Phillips head.
 The instructions are generic, the figures may vary.
 Keep all parts and components out of the reach of children.

ATENCIÓN

Esa embalaje contiene piezas pequeñas, mantenga lejos de los chicos hasta el producto estea totalmente armado.
 Montaje debe ser hecha por adultos!
 Utilizar parafusadeira com cabeça Phillips!
 Las instrucciones son genericas, los dibujos pueden variar.
 Mantenga todas las piezas y componentes fuera del alcance de los niños.

MONTAGEM DO PRODUTO / PRODUCT ASSEMBLY / MONTAJE DEL PRODUCTO

PASSO / STEP / PASO 7

Encaixe o canal das peças N°04 e 05 nas peças N°11 e N°12 e parafuse utilizando 'B'.
 Unir as peças N°04 e 05 utilizando 'G' e 'C'. Fixe 'Q' com 'C' nas peças N°11 e N°12.
 Cole as tampas adesivas 'S'.

Put the channel on the pieces N°04 and 05 on the pieces N°11 and N°12 and fix using 'B'.
 Connect the pieces N°04 and 05 using 'G' and 'C'. Fix 'Q' with 'C' on the pieces N°11 and N°12.
 Paste the adhesives label 'S'.

Encaje el canal de las piezas N°04 y 05 en las piezas N°11 y N°12 y fije utilizando 'B'.
 Una las piezas N°04 y 05 utilizando 'G' y 'C'. Fije 'Q' con 'C' en las piezas N°11 y N°12.
 Pegue las tapas adhesivas 'S'.

B 04 und. Parafuso 4,0 x 40 CC Screw 4,0 x 40 CC Tornillo 4,0 x 40 CC	C 10 und. Parafuso 3,5 x 12 CC Screw 3,5 x 12 CC Tornillo 3,5 x 12 CC	G 01 und. Chapa 2 Furos Flat Plate Bracket Placa de metal conector
K 02 und. Cola Glue Pegamento	Q 02 und. Chapa 4 Furos Flat Plate Bracket Placa de metal conector	S 04 und. Tampa Adesiva 12mm Rosa Adhesive Label 12mm Pink Tapa Adhesiva 12mm Rosa

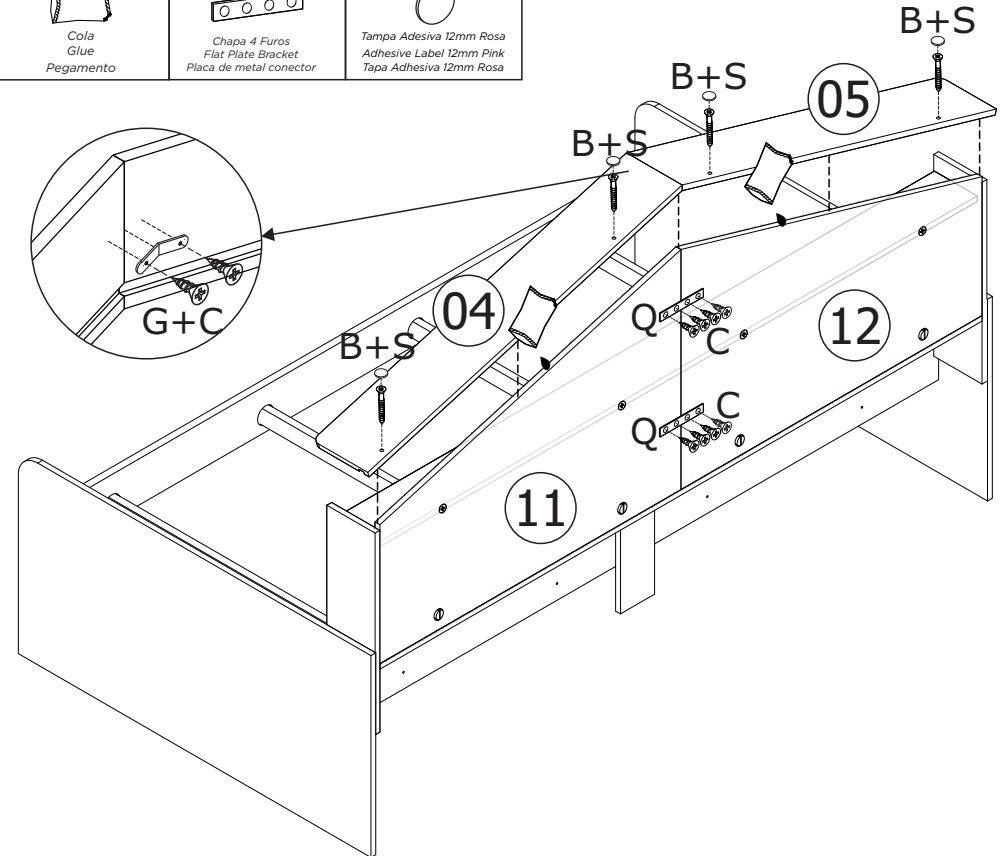

MONTAGEM DO PRODUTO / PRODUCT ASSEMBLY / MONTAJE DEL PRODUCTO



PASSO / STEP / PASO 6

Fixe as peças N°11 e N°12 utilizando parafusos 'A' e porca 'E'.
Cole as tampas adesivas 'J'.

Fix the pieces N°11 and N°12 using 'A' and 'E'.
Paste 'J'.

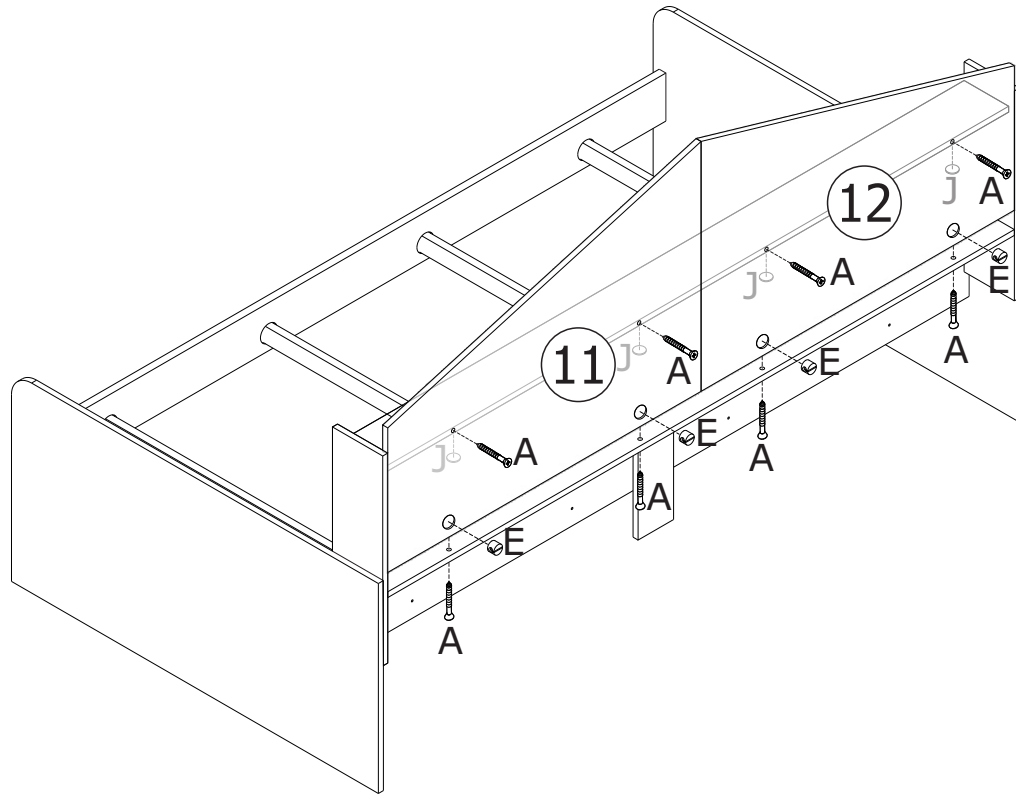
Fije las piezas N°11 y N°12 utilizando 'A' y 'E'.
Pegue 'J'.

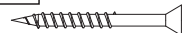

A	08 und.	E	04 und.	J	04 und.
					
Parafuso 5,0 x 50 CC Screw 5,0 x 50 CC Tornillo 5,0 x 50 CC		Porca Cilíndrica Plástica 12x09 Plastic Nuts 12x09 Tuerca Cilíndrica Plástica 12x09		Tampa Adesiva 18mm Branca Adhesive Label 18mm White Tapa Adhesiva 18mm Blanca	

PESO SUPORTADO / DIMENSÕES PRODUTO MONTADO
SUPPORTED WEIGHT / DIMENSIONS ASSEMBLED PRODUCT
PESO SOPORTADO / DIMENSIONES PRODUCTO ARMADO

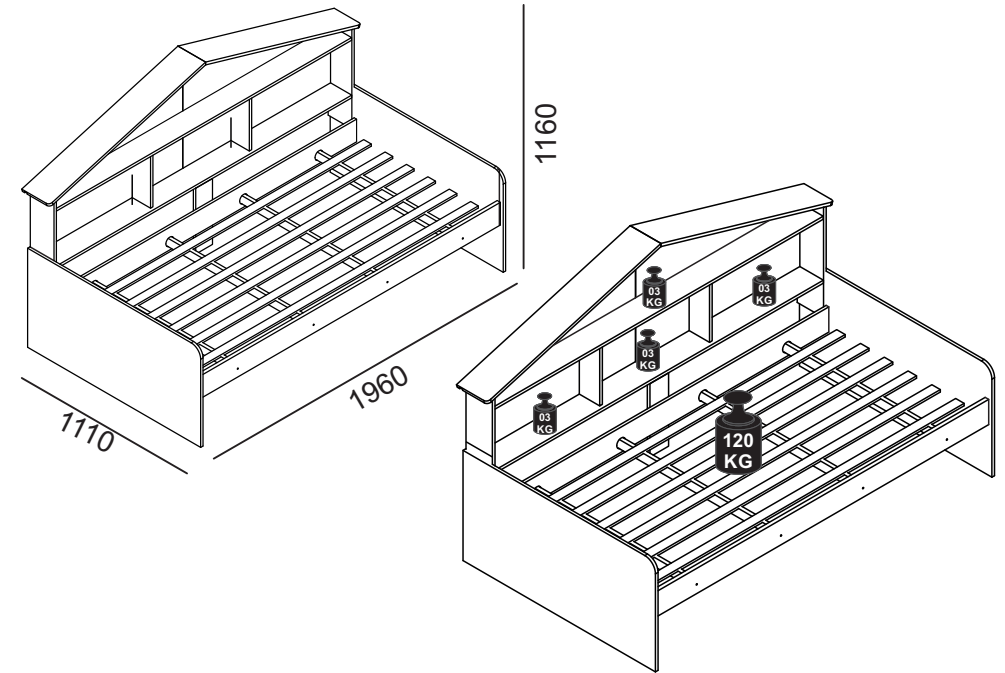

DICAS IMPORTANTES

1. Leia atentamente todas as instruções antes de iniciar a montagem.
2. Separe e guarde a etiqueta de identificação.
3. Confira se os volumes e quantidades de peças descritos no manual estão corretos.
4. Identifique as peças e separe os acessórios.
5. A montagem do produto deverá ser feita em uma superfície limpa e plana. Aconselhamos utilizar a própria embalagem para forrar o chão afim de não danificar o produto.
6. Reserve área livre para montagem do produto.
7. Evite batidas e o contato com objetos cortantes.

Limpeza e Conservação

1. Não expor o móvel a calor excessivo (luz solar direta), ou umidade elevada.
2. Para limpeza use um pano macio seco ou ligeiramente umedecido com água. Não use agentes de limpeza ou abrasivos.

IMPORTANT TIPS

1. Read all instructions before beginning assembly.
2. Separate and store the identification label.
3. Confirm the volumes and quantities of parts described in the manual.
4. Identify and separate the parts and accessories.
5. The assembly of the product should be done on a clean and flat surface. We recommend using the package itself to cover the floor to prevent product damage.
6. Reserve free area for product assembly.
7. Avoid impacts and contact with sharp objects.

Cleaning and Conservation

1. Do not expose the product to excessive heat (direct sunlight) or high humidity.
2. For cleaning use a dry or slightly moistened soft cloth with water. Do not use cleaning agents or abrasives.

FERRAMENTAS NECESSÁRIAS TOOLS REQUIRED / HERRAMIENTAS NECESARIAS

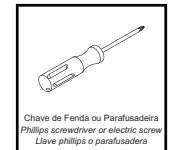
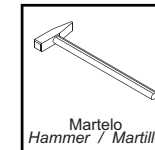

DICAS IMPORTANTES

1. Leer atentamente todas las instrucciones antes de empezar el montaje.
2. Separe y guarde las etiquetas de identificación.
3. Mire si los volúmenes y cantidades de piezas descritos en manual están correctos.
4. Identifique las piezas y separe los accesorios.
5. El montaje del producto debe realizarse sobre una superficie limpia y plana. Le recomendamos que utilice la propia embalaje para cubrir el suelo para evitar daños en el producto.
6. Dejar una area libre para armar el producto.
7. Evite impactos y contacto con objetos cortantes.

Limpeza y Conservación

1. No dejar el producto en locales muy calientes (luz del sol directa) o demasiada umidade.
2. Para la limpieza utilizar un paño suave y seco o ligeramente humedecido con agua. No utilice productos abrasivos.

IDENTIFICAÇÃO DAS PEÇAS
IDENTIFICATION OF PARTS / IDENTIFICACIÓN DE LAS PIEZAS

CÓD.	IDENTIFICAÇÃO DAS PEÇAS	IDENTIFICATION OF PARTS	IDENTIFICACIÓN DE LAS PIEZAS
01	Barra Traseira	Back Bar	Barra Trasera
02	Peseira	Footboard	Piecero
03	Cabeceira	Headboard	Cabecera
04	Telhado Casa Direito	Right Roof House	Tejado Derecho de la Casa
05	Telhado Casa Esquerdo	Left Roof House	Tejado Izquierdo de la Casa
06	Barra Frontal	Front Bar	Barra de la Frente
07	Laterais da Casa	House Side	Lados de la Casa
08	Travessa Superior Casa	Top Support House	Travesa Superior de la Casa
09	Travessa Inferior Casa	Standard Support House	Travesa Inferior de la Casa
10	Divisórias	Division	División
11	Painel Traseiro Direito	Right Back Panel	Panel Trasero Derecho
12	Painel Traseiro Esquerdo	Left Back Panel	Panel Trasero Izquierdo
12	Pé Traseiro	Back Foot	Pie Trasero
12	Longarina	Stringer	Zanca
12	Travessa do Estrado	Bed Slats Support	Travesa del estrado

ASSISTÊNCIA TÉCNICA

Ao solicitar assistência técnica, informe o número da peça, nome e cor do produto e a data de fabricação do lote que se encontra carimbado na peça nº14.

TECHNICAL ASSISTANCE

When request the technical assistance, inform the number of the piece name and color of the product and also the batch manufacturing date, that is stamped on the

ASISTENCIA TÉCNICA

Al solicitar la asistencia técnica, informe el número de la pieza, el nombre y el color del producto y también la fecha de fabricación del lote, que se estampa en la pieza nº14.

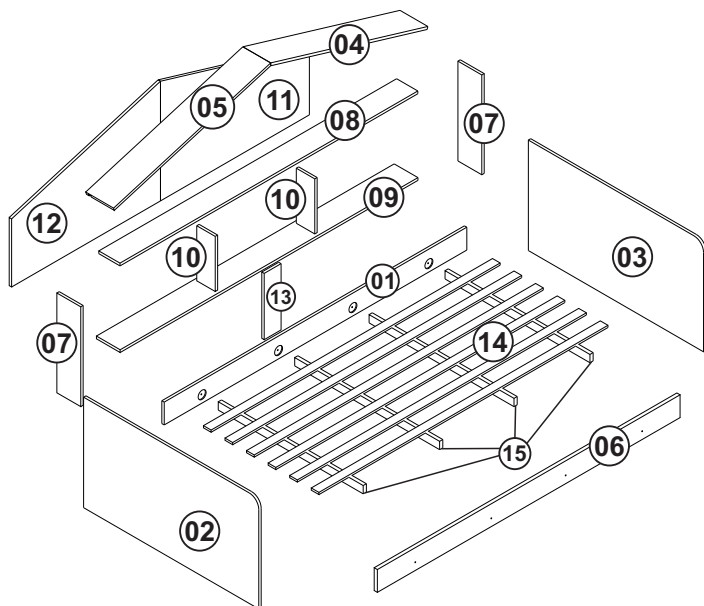

MONTAGEM DO PRODUTO / PRODUCT ASSEMBLY / MONTAJE DEL PRODUCTO

PASSO / STEP / PASO 5

Fixe o quadro da casa nas peças N° 02 e N°03 utilizando 'L'.

Fix the house frame on the pieces N° 02 and N°03 using 'L'.

Fije el marco de la casa en las piezas N° 02 y N°03 utilizando 'L'.

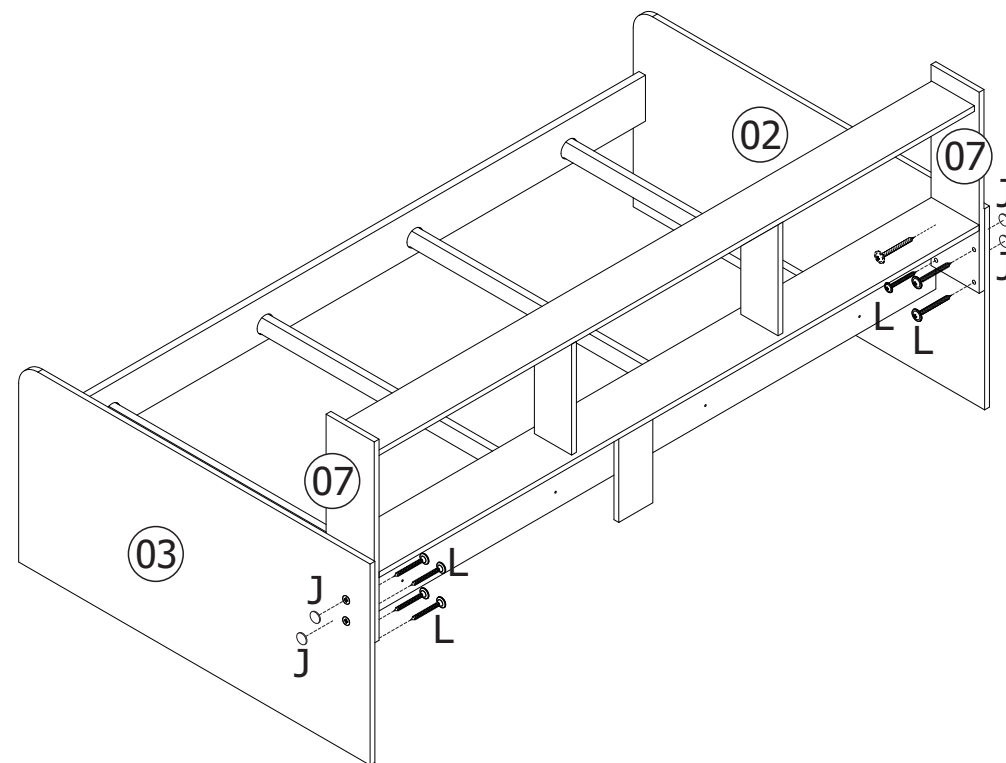

J	04 und.	L	08 und.
Tampa Adesiva 18mm Branca		Parafuso 4,0 x 25 Franjeado	
Adhesive Label 18mm White		Screw 4,0 x 25 Flanged	
Tapa Adhesiva 18mm Blanca		Tornillo 4,0 x 25 Franjeado	



MONTAGEM DO PRODUTO / PRODUCT ASSEMBLY / MONTAJE DEL PRODUCTO

PASSO / STEP / PASO 4

Fixe as divisórias N°10 nas peças N°08 e N°09 utilizando 'A'.
Fixe as laterais N°07 utilizando 'A'. Cole as tampas 'J'.

Fix the pieces N°10 on the pieces N°08 and N°09 using 'A'.
Fix the pieces N°07 using 'A'. Paste 'J'.

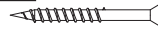



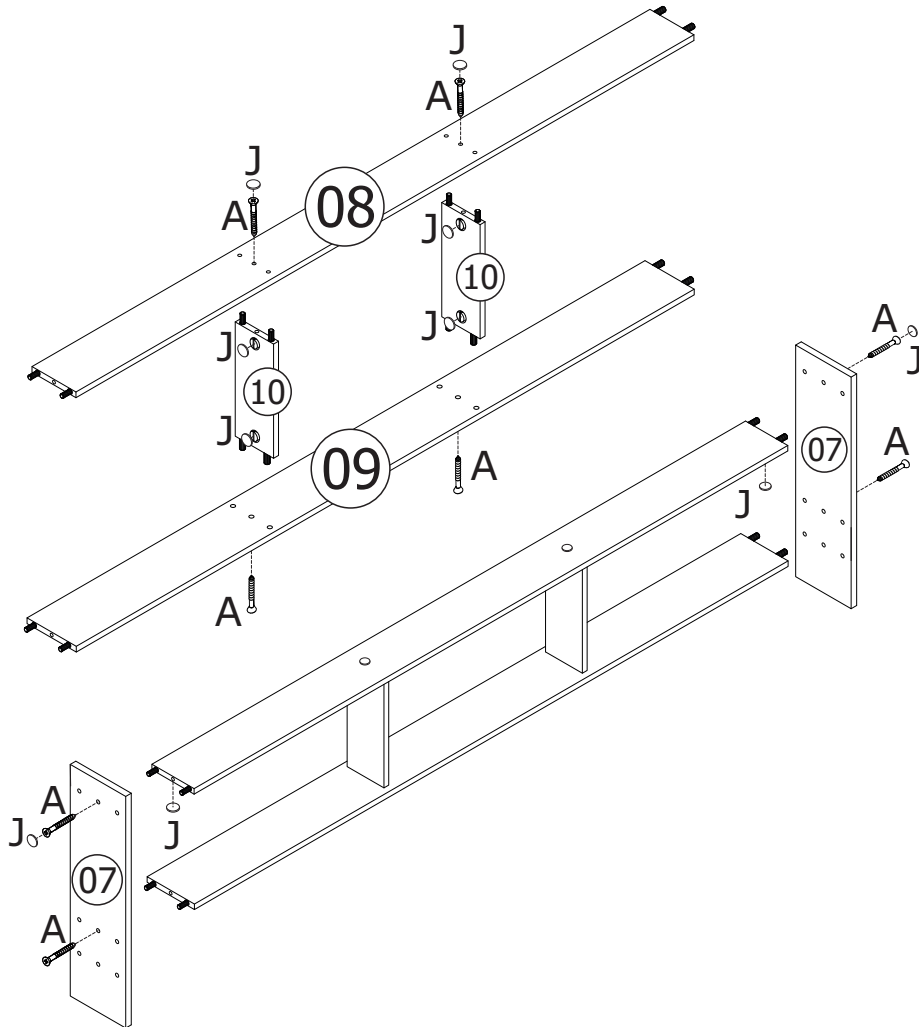











Fije las piezas N°10 en las piezas N°08 y N°09 utilizando 'A'.
Fije las piezas N°07 utilizando 'A'. Pegue 'J'.

A 08 und.	J 10 und.
	
Parafuso 5,0 x 50 CC Screw 5,0 x 50 CC Tornillo 5,0 x 50 CC	Tampa Adesiva 18mm Branca Adhesive Label 18mm White Tapa Adhesiva 18mm Blanca

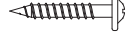

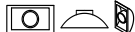
FERRAGENS

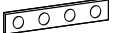
IRONMONGERY / HERRAJES

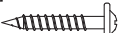
A 20 und.	B 12 und.	C 10 und.	D 32 und.	E 20 und.
				
Parafuso 5,0 x 50 CC Screw 5,0 x 50 CC Tornillo 5,0 x 50 CC	Parafuso 4,0 x 40 CC Screw 4,0 x 40 CC Tornillo 4,0 x 40 CC	Parafuso 3,5 x 12 CC Screw 3,5 x 12 CC Tornillo 3,5 x 12 CC	Prego Ardox 12 x 12 Nail Ardox 12 x 12 Clavo Ardox 12 x 12	Porca Cilíndrica Plástica 12x09 Plastic Nuts 12x09 Tuerca Cilíndrica Plástica 12x09
F 15 und.	G 01 und.	H 04 und.	I 08 und.	J 18 und.
				
Cavilha 8 x 30 Dowel 8 x 30 Clavija 8 x 30	Chapa 2 Furos Flat Plate Bracket Placa de metal conector	Sapata Deslizadora Shoes Zapata	Suporte Plástico Plastic Support Soporte plastico	Tampa Adesiva 18mm Branca Adhesive Label 18mm White Tapa Adhesiva 18mm Blanca
K 02 und.	L 08 und.	M 02 und.	N 04 und.	O 04 und.
				
Cola Glue Pegamento	Parafuso 4,0 x 25 Franjeado Screw 4,0 x 25 Flanged Tornillo 4,0 x 25 Franjeado	Cavilha 6 x 30 Dowel 6 x 30 Clavija 6 x 30	Parafuso CPL 1/4 x 3" Screw CPL 1/4 x 3" Tornillo CPL 1/4 x 3"	Porca Elíptica Elliptical Nut Tuerca Elíptica
P 04 und.	Q 02 und.	R 04 und.	S 08 und.	T 02 und.
				
Tapa Parafuso CPL Screw Cap CPL Tapa Tornillo CPL	Chapa 4 Furos Flat Plate Bracket Placa de metal conector	Cavilha 8 x 50 Dowel 8 x 50 Clavija 8 x 50	Tampa Adesiva 12mm Rosa Adhesive Label 12mm Pink Tapa Adhesiva 12mm Rosa	Parafuso 4,0 x 30 Franjeado Screw 4,0 x 30 Flanged Tornillo 4,0 x 30 Franjeado

FERRAGENS ESCALA REAL / REAL SCALE IRONMONGERY / HERRAJES EN TAMAÑO COMPLETO

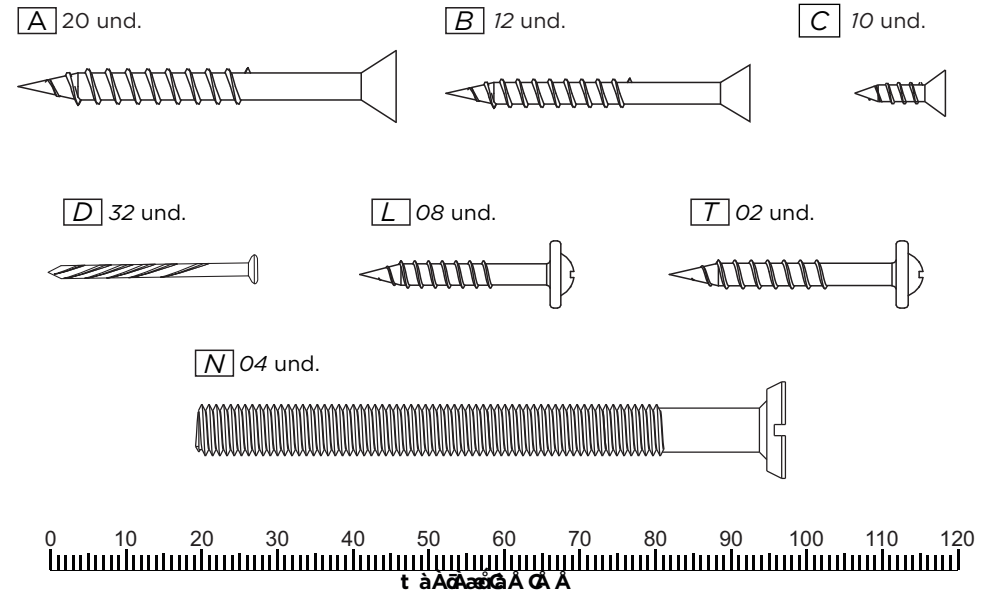



MONTAGEM DO PRODUTO / PRODUCT ASSEMBLY / MONTAJE DEL PRODUCTO

PASSO / STEP / PASO 1

Prepare as peças N° 01, 06, 08, 09 e 10 utilizando 'E', 'F', 'M', 'O' e 'R'.
Fixe 'H' nas peças N°02 e 03 utilizando 'D'.

Prepare the pieces N° 01, 06, 08, 09 and 10 using 'E', 'F', 'M', 'O' and 'R'.
Fix 'H' on the pieces N°02 and 03 using 'D'.

Prepárese las piezas N° 01, 06, 08, 09 y 10 utilizando 'E', 'F', 'M', 'O' y 'R'.
Fije 'H' en las piezas N°02 y 03 utilizando 'D'.

D 08 und.	R 04 und.
	
Preço Ardox 12 x 12 Nail Ardox 12 x 12 Clavo Ardox 12 x 12	Cavilha 8 x 50 Dowel 8 x 50 Clavija 8 x 50

E 16 und.

Porca Cilíndrica Plástica 12x09 Plastic Nuts 12x09 Tuerca Cilíndrica Plástica 12x09

F 14 und.

Cavilha 8 x 30 Dowel 8 x 30 Clavija 8 x 30

H 04 und.

Sapata Deslizadora Shoes Zapata

M 02 und.

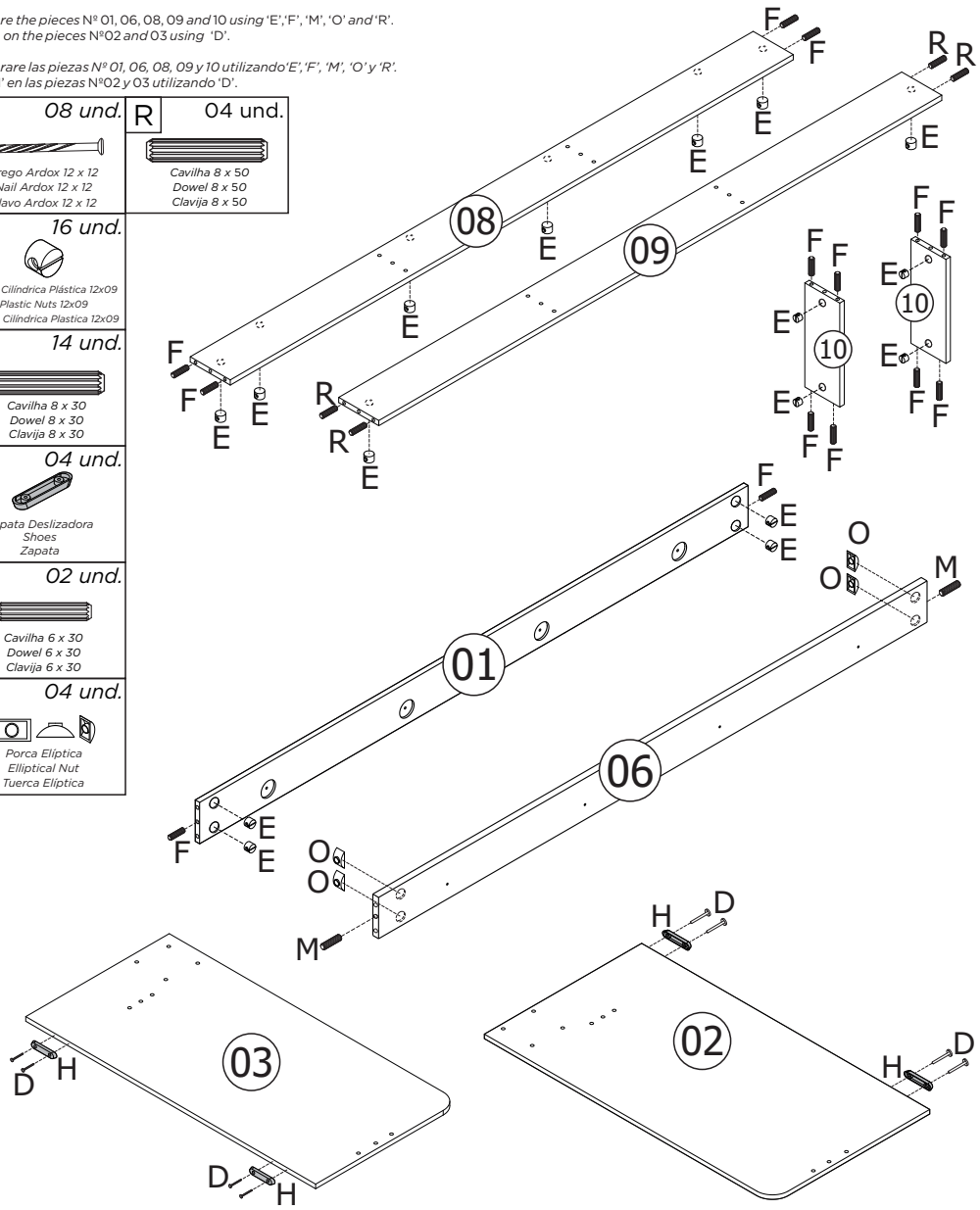
Cavilha 6 x 30 Dowel 6 x 30 Clavija 6 x 30

O 04 und.

Porca Elíptica Elliptical Nut Tuerca Elíptica





MONTAGEM DO PRODUTO / PRODUCT ASSEMBLY / MONTAJE DEL PRODUCTO

PASSO / STEP / PASO 2

Fixe as peças N°15 nas barras N°01 e 06 utilizando 'B' e 'I'. Cole as tampas 'S'.

Fix the pieces N°15 on the pieces N°01 and 06 using 'B' and 'I'. Paste 'S'.

Fije las piezas N°15 en las piezas N°01 y 06 utilizando 'B' y 'I'. Pegue 'S'.

B 08 und.

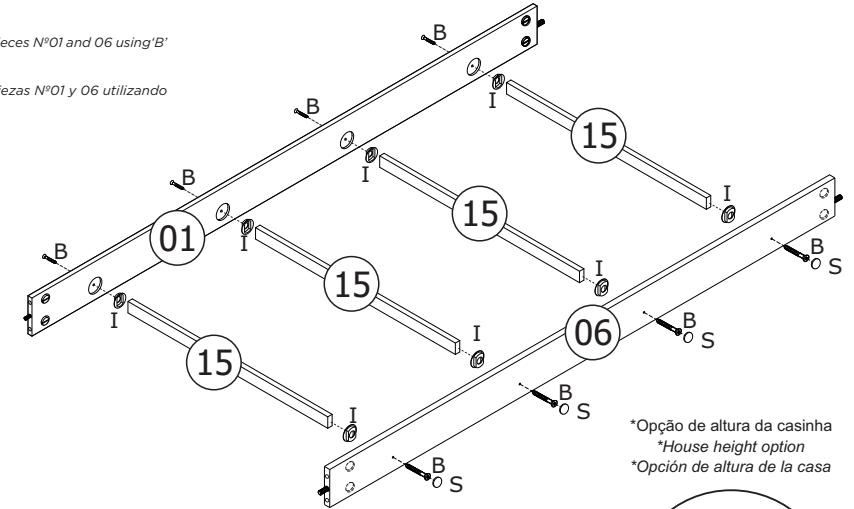
Parafuso 4,0 x 40 CC Screw 4,0 x 40 CC Tornillo 4,0 x 40 CC
I 08 und.

Suporte Plástico Plastic Support Soporte plástico
S 04 und.

Tampa Adesiva 18mm Rosa Adhesive Label 18mm Pink Tapa Adhesiva 18mm Rosa



*Opção de altura da casinha
*House height option
*Opción de altura de la casa

PASSO / STEP / PASO 3





Unir as peças N°01 e N°06 nas peças N°02 e N°03 utilizando 'A' e 'N'.
Fixe a peça N°13 utilizando 'T'. Cole as tampas 'P'.

Connect the pieces N°01 and N°06 on the pieces N°02 and N°03 using 'A' and 'N'.
Fix the piece N°13 using 'T'. Paste 'P'.

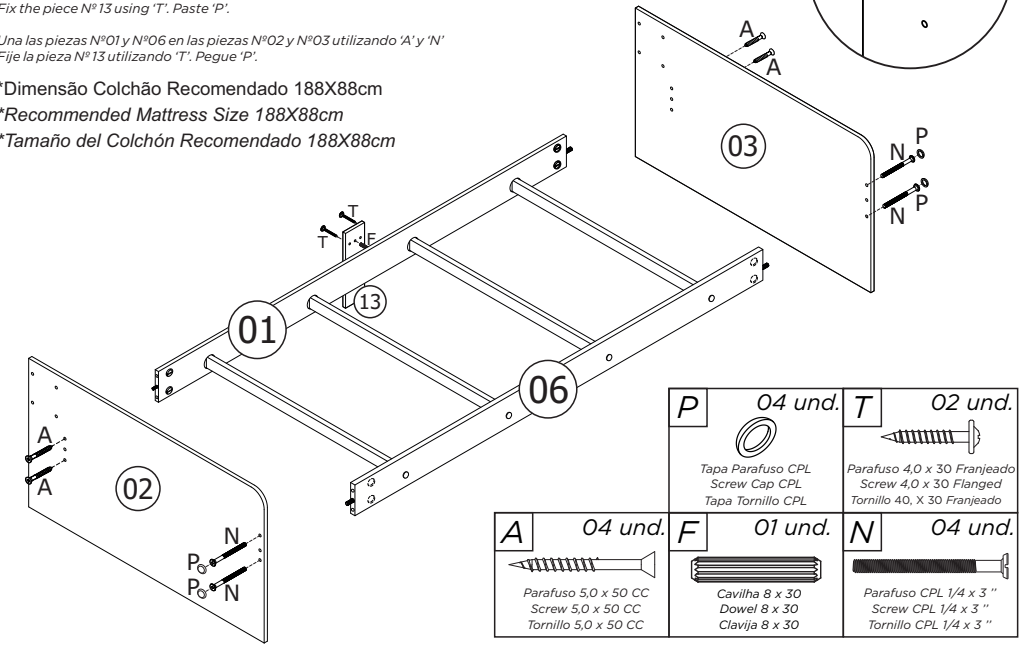
Una las piezas N°01 y N°06 en las piezas N°02 y N°03 utilizando 'A' y 'N'.
Fije la pieza N°13 utilizando 'T'. Pegue 'P'.

*Dimensão Colchão Recomendado 188X88cm
*Recommended Mattress Size 188X88cm
*Tamaño del Colchón Recomendado 188X88cm



A 04 und.	F 01 und.	N 04 und.	P 04 und.	T 02 und.
				
Parafuso 5,0 x 50 CC Screw 5,0 x 50 CC Tornillo 5,0 x 50 CC	Cavilha 8 x 30 Dowel 8 x 30 Clavija 8 x 30	Parafuso CPL 1/4 x 3" Screw CPL 1/4 x 3" Tornillo CPL 1/4 x 3"	Tapa Parafuso CPL Screw Cap CPL Tapa Tornillo CPL	Parafuso 4,0 x 30 Franjeado Screw 4,0 x 30 Flanged Tornillo 4,0 x 30 Franjeado