

DETALHAMENTO EXTERNO
 Outer detail / Detalle externo

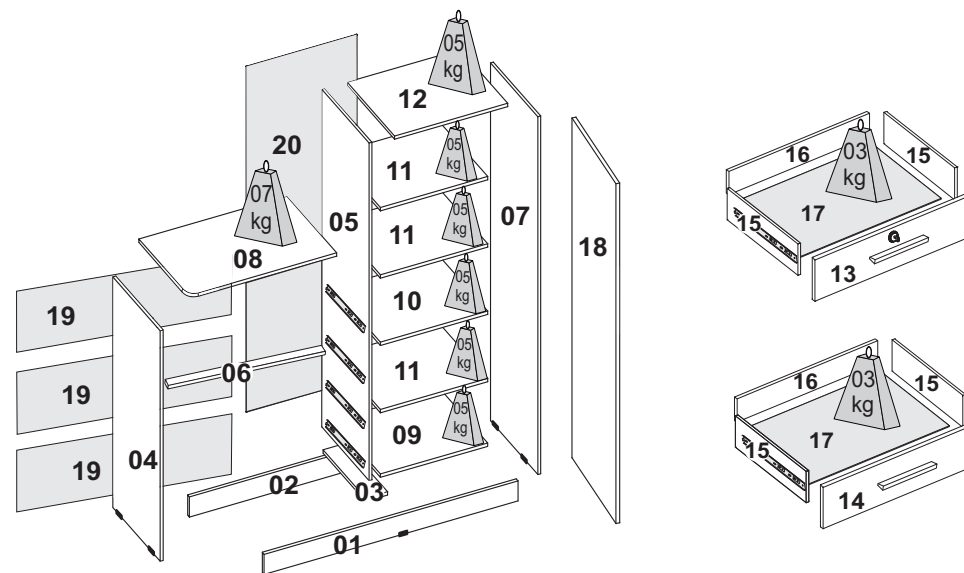

DETALHAMENTO INTERNO
 Inside detail / Detalle interno



INSTRUÇÃO MONTAGEM PRODUTO

Intructions to Assembly / Instrucciones de montaje

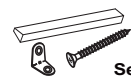

Separe as peças e acessórios de maneira organizada
 Separate parts and accessories in way organized
 Separe las piezas y accesorios de manera organizada

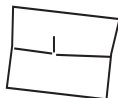

Forrar o chão com o papelão das embalagens.
 Cover the floor with the cardboard
 Cubra el suelo con la embalaje de cartón



É necessário 01 pessoa para montar o produto
 It is necessary one person to assembly
 Es necesario una persona para ensamblar

O produto deve ser a montado por um profissional qualificado
 The product must be assembly by a professional
 El producto debe ser ensamblado por un profesional calificado

Ferramentas necessárias
 (não fornecidas)



Not include tools / No herramientas

CUIDADO PARA CONSERVAÇÃO E LIMPEZA DO MÓVEL

Care to conservation and clean / Cuidados de limpieza



O peso máximo de carga informado refere-se a objetos distribuído de maneira uniforme sobre toda área de contato da peça
 Set maximum weight load refers to objects distributed uniformly over the entire contact area of the workpiece.

Conjunto de carga máxima de peso se refere a objetos distribuídos uniformemente sobre toda el área de contacto de la pieza de trabajo.



Não molhar o móvel e não expor em lugar úmido
 Do not wet the mobile and do not expose in a wet place
 No moje el producto y no exponer en un lugar húmedo



Não expor o móvel próximo de fontes de calor.
 Do not expose the mobile near heat sources
 no exponga cercano de fuentes de calor

















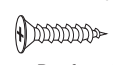

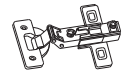

Não usar produtos abrasivos.
 Do not use abrasive products.
 No utilice productos abrasivos.



Limpe com flanela limpa e seca.
 Clean with dry cloth

Limpieza con un paño limpio y seco

LISTA DE ACESSÓRIOS E FERRAGEM
ACCESSORIES AND HARDWARE / ACCESORIOS Y EQUIPOS

 18PÇS A Cavilha - 6x30 madeira Dowel / Clavija	 20PÇS B Parafuso 4,5x45 Screw / Tornillo	 26PÇS C Parafuso -3,5x28 Screw / Tornillo	 74PÇS D Parafuso -3,0x12 Screw Tornillo	 70PÇS E Parafuso -3,5x12 Screw Tornillo	 70PÇS F Prego - 10x10 Nail / Clavo
 04PÇ G Dobradiça metal Hinge / Bisagra	 12PÇS H Suporte prateleira plástico Shelf Support / Soporte	 04PÇS I Sapata 12 mm plástico Shoe / Zapata	 02PÇS J Sapata 15 mm plástico Shoe / Zapata	 01PÇ K Fecho rolete metal Roller Closing / Cierre	 01PÇ L Sache cola 20g Glue / Goma
 18PÇS M Cantoneira Corner / Esquinero	 6PÇS N Junção traseira metal Rear Junction / Unión	 05PÇS O Puxador 250 mm Handle / Manija	 01PÇ P Kit fechadura metal Lock Kit / Cerradura	 04PÇS Q Kit corredeira telescópica 300 mm meta Slider / Correderal	 02PÇS R Perfil H 590mm Frame / perfil

LISTA DE PEÇAS / Pieces List / Lista de Piezas

Nº	DESCRIÇÃO			MAT.	MEDIDAS	QTDE
1	LATERAL EXT. ESQUERDA	LATERAL EXT. LEFT	LATERAL EXT IZQUIERDA	MDP	360x295x15	1
2	LATERAL EXT. DIREITA	LATERAL EXT. RIGHT	LATERAL EXTDERECHO	MDP	360x295x15	1
3	BASE	BASE	BASE	MDP	295x268x15	2
4	TAMPO	TOP	TAMPO	MDP	295x268x15	2
5	DIVISÓRIA DIREITA	RIGHT DIVISION	REPARTO DERECHO	MDP	360x295x15	1
6	DIVISÓRIA ESQUERDA	LEFT DIVISION	REPARTO IZQUIERDO	MDP	360x295x15	1
7	PRATELEIRACENTRAL	CENTRAL SHELF	PLATAFORMACENTRAL	MDP	720x265x15	1
8	DIVISÓRIA	SPLIT	PARTICIÓN	MDP	265x88x15	3
9	VISTA FRONTAL	FRONT VIEW	VISTA FRONTAL	MDP	720x145x15	1
10	PAINEL	PANEL	PANEL	MDP	1355x448x15	1
11	PORTAC/ ESPELHO	DOOR WITH MIRROR	PUERTAC / ESPEJO	MDP	710x292x15	1
12	TRAVA LATERAL	LATERALLATCH	LATERAL DE CERROJO	MDP	447x88x15	2
13	TRAVA MACHO/FEMEAC/ BORDA	MALE LOCK / FEMALE WITH EDGE	LATCH	MDP	1080x88x15	1
14	TRAVAMACHO/FEMEA	LATCH MALE / FEMALE	LATCH	MDP	1030x88x15	1
15	PRATELEIRA MÓVEL	MOBILE SHELF	PLATAFORMA MÓVIL	MDP	279x268x15	2
16	PORTA DIREITA	RIGHT DOOR	PUERTA DERECHA	MDP	322x263x15	1
17	PORTA ESQUERDA	LEFT DOOR	PUERTA IZQUIERDA	MDP	322x263x15	1
12	OBS:TRAVA LATERAL É CRU, APENAS FITA DE BORDA NA COR DE	OBS: LATERAL LATCH IS RAW, ONLY EDGE RIBBON IN PRODUCT COLOR	NOTA: LA TRAVA LATERALÉS CRUDA, LAS LLANTAS DE BORDA EN COLOR DEL PRODUCTO			

PASSO 1 Prepare a peça 4,5 e 7 utilizando as ferragens (A,D,E,F,G,H,I,K,M e Q). Prepare a peça 18 utilizando as ferragens (C,E,G,O e K).

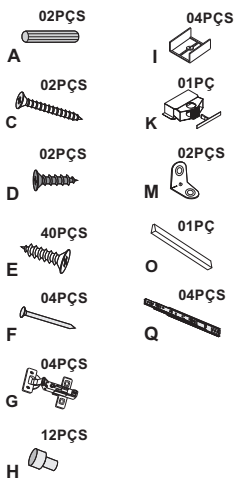

Colocar 3º parafuso no primeiro furo da correia.
Put the 3rd screw in the first hole.
Ponga el tercer tornillo en el hoyo.

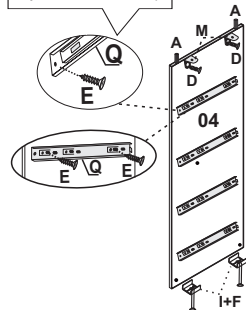

STEP 1 Prepare the piece 4,5 and 7 using the tools (A,D,E,F,G,H,I,K,Q and M). Prepare the 18 using the (C,E,G,O and K).

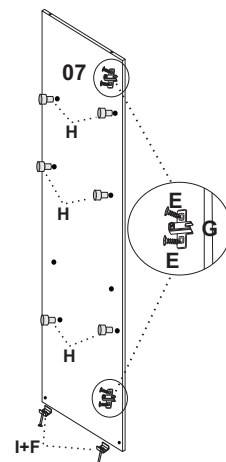
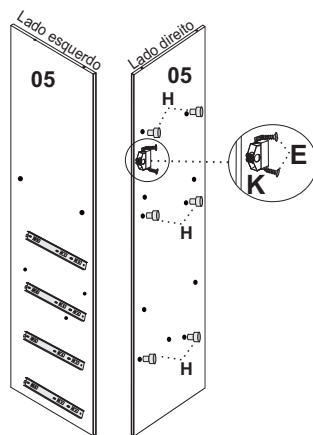

PASO 1 Prepare la pieza 4,5 y 7 usando las herramientas (A,D,E,F,G,H,I,K,Q y M). Prepare la 18 usando las (C,E,G,O y K).

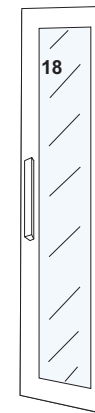
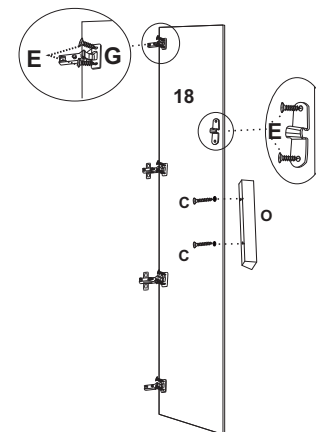

PASSO 2 Prepare as peças 1 e 2 utilizando as ferragens (F e J). Fixe a peça 3 nas peças 1 e 2 utilizando a ferragem (B).
STEP 2 Prepare the pieces 1 and 2 using the tools (F and J). Fix the 3 in the 1 and 2 using (B).
PASO 2 Prepare las piezas 1 y 2 usando (F y J). Fije la pieza 3 en las 1 y 2 usando (B).

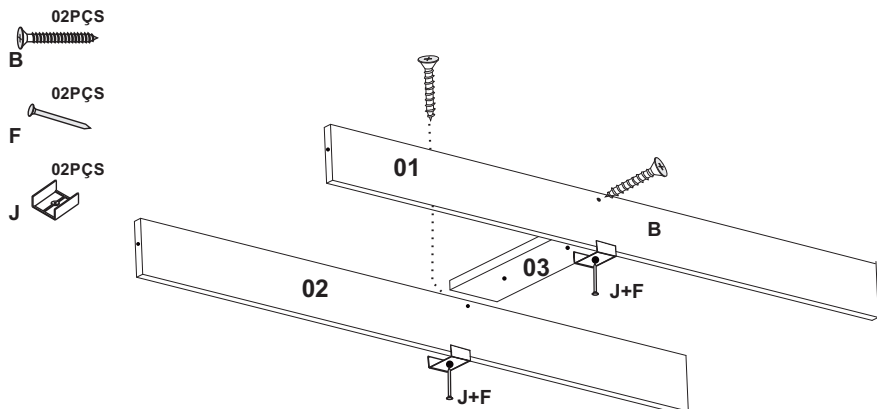

PASSO 3 Fixe a peça 5 na peça 3 utilizando a ferragem (B).
STEP 3 Fix the piece 5 in the 3 using the tool (B).
PASO 3 Fije la pieza 5 en la 3 usando la herramienta (B).

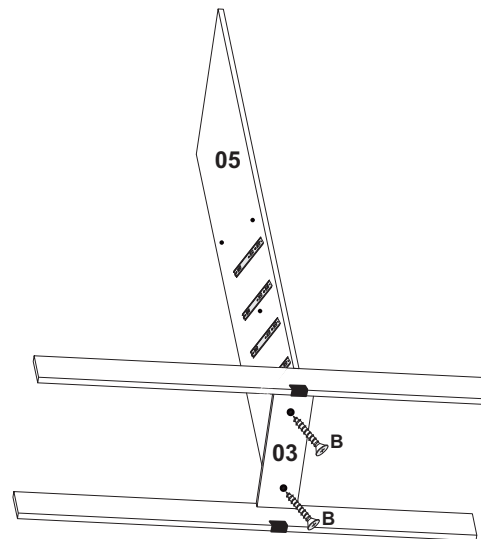

PASSO 4 Fixe a peça 6 na peça 5 utilizando a ferragem (B)
 Fixe a peça 4 nas peças 1,2 e 6 utilizando a ferragem (B)

STEP 4 Fix the piece 6 in the 5 using the tool (B). Fix the 4 in the 1,2 and 6 using (B)
PASO 4 Fije la pieza 6 en la 5 usando la herraje (B). Fije la 4 en las 1,2 y 6 usando (B)

04PÇS
B

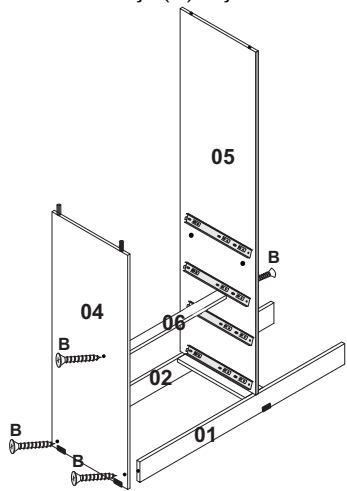

PASSO 6 Fixe a peça 18 na peça 7 utilizando a ferragem (E).

STEP 6 Fix the piece 18 in the 7 using the tool (E).

PASO 6 Fije la pieza 18 en la 7 usando la herraje (E).

04PÇS
E

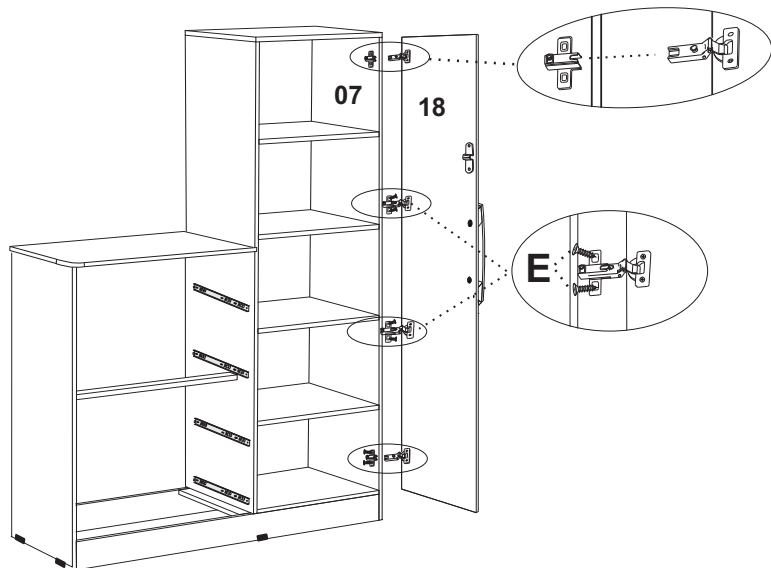

PASSO 5 Fixe a peça 7 nas peças 1 e 2 utilizando a ferragem (B).
 Fixe as peças 10 e 12 nas peças 5 e 7 utilizando a ferragem (B).
 Fixe a peça 8 nas peças 4 e 5 utilizando a ferragem (B e D).

STEP 5 Fix the 7 in the 1 and 2 using (B). Fix the 10 and 12 in the 5 and 7 using (B).
 Fix the 8 in the 4 and 5 using (B e D).

PASO 5 Fije la 7 en las 1 y 2 usando (B). Fije la 10 y 12 en las 5 y 7 usando (B).
 Fije la 8 en las 4 y 5 usando la (B e D).

12PÇS
B
02PÇS
D

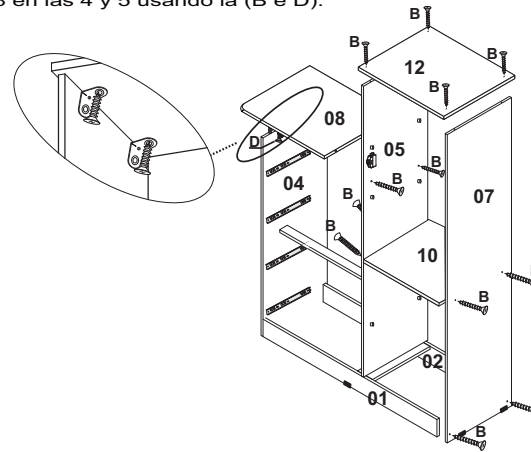

PASSO 7 Ao pregar os fundos inicie pregando peça 19 encaixando o acessório (R) entre as duas peças dividindo os espaços. Pregue a peça 20 utilizando também a ferragem (N).

STEP 7 By preaching the funds start preaching piece 19 fitting the accessory (R) between the two parts dividing the space. Nail piece 20 also using hardware (N).

PASO 7 Al poner clavos en los fondos comienze con la pieza 19 encaje (R) entre las dos piezas dividiendo los espacios. Ponga clavos en la 20 usando (N).

33PÇS
F
06PÇS
N
02PÇS
R

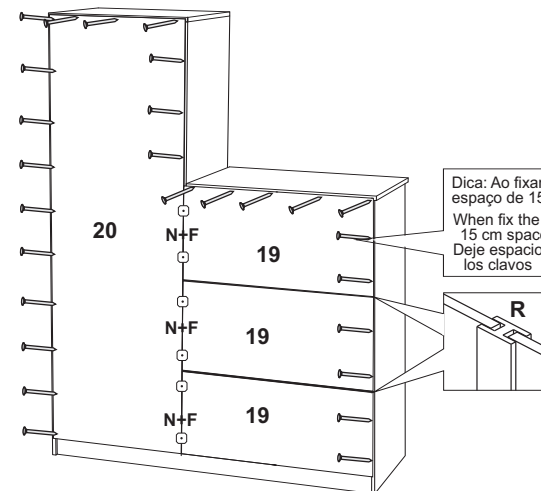

Dica: Ao fixar os fundos deixar espaço de 15 cm entre os pregos.
 When fix the background leave 15 cm space between the nails
 Deje espacio de 15 cm entre los clavos

PASSO 1 Preparar as peças 15 utilizando as ferragens(A,M,D e L)
E fixar na peça 14.Fixar a peça 16 nas peças 15 utilizando a ferragem(C)
Fixar o acessório(O)na peça14 utilizando a ferragem (C).

STEP 1 Prepare the 15 using (A,M,D and L) and fix in the 14. Fix the 16 in the 15 using (C).
Fix the (O) in the 14 using (C).

PASO 1

- 12PÇS
- A
- 18PÇS
- C
- 24PÇS
- D
- 01PÇ
- L
- 12PÇS
- M
- 03PÇS
- O

Fazer par na lateral da gaveta
Make couple on the side
Hacer par en la lateral

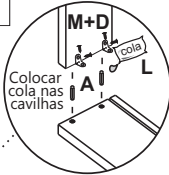

MONTAGEM DA GAVETA S/ CHAVE
DRAWER ASSEMBLY / MONTAJE DE CAJÓN

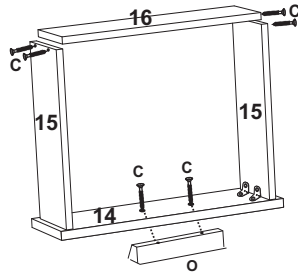

PASSO 2 Fixar o acessório (Q) nas peças 15 utilizando a ferragem (E).
Fixar a peça 17 nas peças 15 e 16 utilizando as ferragens (D e F).

STEP 2 Fix the (Q) in the 15 using (E). Fix the 17 in the 15 and 16 using (D and F).

PASO 2 Fije (Q) en la 15 usando (E). Fije 17 en la 15 y 16 usando (D y F).

- 30PÇS
- D
- 18PÇS
- E
- 18PÇS
- F
- L
- 03PÇS
- Q

Dica: Passar cola na peça 15 e 16 para ajudar a fixar a peça 17.
Tip: Put glue in the 15 and 16 to fix 17.
Ponga goma en la 15 y 16 para fijar la 17

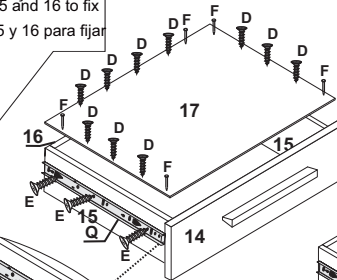
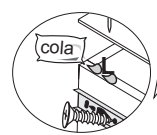

Dica: Colocar corredeira na marcação da lateral
Put the slide in the mark
Ponga la corredera en la marca

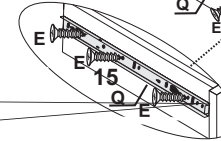

Repetir processo nas três gavetas
Repeat the process in all drawers
Repetir el proceso en los cajones

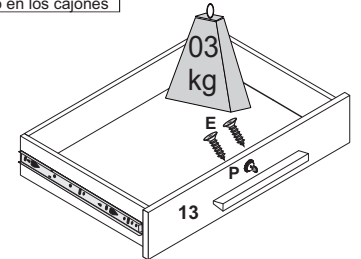
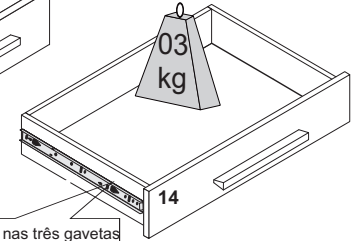

ASPECTO FINAL DO PRODUTO
FINAL ASPECT / ASPECTO FINAL

