

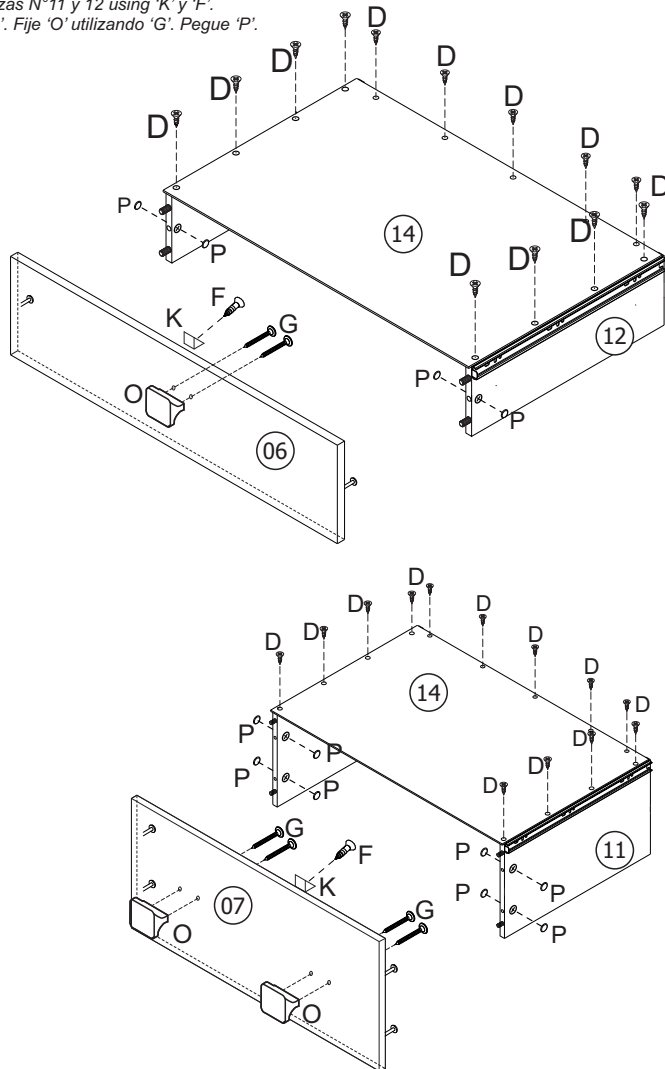





## PASSO / STEP / PASO 8

Fixe as peças N°06 e 07 nas peças N°11 e 12 utilizando 'K' e 'F'.  
Fixe os fundos N°14 utilizando 'D'.  
Fixe os puxadores 'O' utilizando 'G'. Cole 'P'.

Fix the pieces N°06 and 07 on the pieces N°11 and 12 using 'K' and 'F'.  
Fix the piece N°14 using 'D'. Fix 'O' using 'G'. Paste 'P'.

Fije las piezas N°06 y 07 en las piezas N°11 y 12 using 'K' y 'F'.  
Fije la pieza N°14 y 'U' utilizando 'D'. Fije 'O' utilizando 'G'. Pegue 'P'.



<b>D</b>	52 und.
	Parafuso 3,0 x 20 CC Screw 3,0 x 20 CC Tornillo 3,0 x 20 CC
<b>F</b>	04 und.
	Parafuso 4,0 x 16 CC Screw 4,0 x 16 CC Tornillo 4,0 x 16 CC
<b>G</b>	10 und.
	Parafuso 4,5 x 30 Franjeado Screw 4,5 x 30 Franjeado Tornillo 4,5 x 30 Franjeado
<b>K</b>	04 und.
	Cantoneira Triangular Triangle Corner Brace Cantoneira Triangular
<b>O</b>	05 und.
	Puxador Handle Tirador
<b>P</b>	20 und.
	Tampa Adesiva 18mm Branca Adhesive Label 18mm White Tapa Adhesiva 18mm Blanco

**M.E. GONÇALVES**  
INDÚSTRIA DE MÓVEIS LTDA.  
Avenida Maracanã, 4244 - Parque Industrial  
Arapongas - PR - Brasil  
Fone: +55 (43) 3274-8800  
www.moveisestrela.com.br

# MANUAL DE INSTRUÇÕES

MANUAL DE INSTRUCCIONES

INSTRUCTION MANUAL

CERTIFICADO

90

dias

GARANTIA

CÔMODA MELODY - 9A  
MELODY - 9A DRESSER  
CÓMODA MELODY - 9A

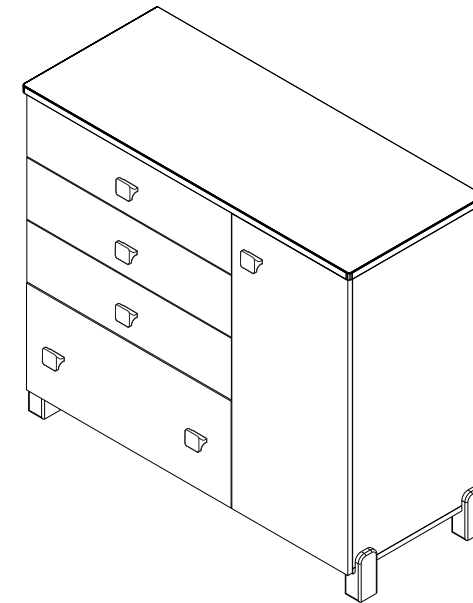

 **Móveis  
Estrela**

SUA CASA, SEU ESTILO

“IMAGENS MERAMENTE ILUSTRATIVAS,  
SUJEITAS À ALTERAÇÕES SEM PRÉVIO AVISO”



1 Adulto  
1 Adult  
1 Adulto

**Pessoas Necessárias para montagem**

*Necessary people for assembly*

**Gente necesaria para el montaje**

**Ferramentas Necessárias (Não Inclusas)**

*Tools needed (not included)*

**Herramientas necesarias (no incluido)**



Martelo  
hammer  
martillo



Parafusadeira  
Screwdriver  
destornillador



Chave Fenda  
Slot Key  
Clave de runura



Chave Phillips  
Phillips Key  
Clave Phillips

## INFORMAÇÕES SOBRE SEGURANÇA

1. Esta embalagem contém peças pequenas, mantenha afastada de crianças até que o produto esteja montado.
2. As instruções são genéricas, as figuras podem variar.
3. Leia atentamente todas as instruções antes de iniciar a montagem.
4. Separe e guarde a etiqueta de identificação.
5. Confira se os volumes e quantidades de peças descritos no manual estão corretos.
6. Identifique as peças e separe os acessórios.
7. A montagem do produto deverá ser feita em uma superfície limpa e plana. Aconselhamos utilizar a própria embalagem para forrar o chão a fim de não danificar o produto.
8. Reservar área livre para montagem do produto.
9. Evitar batidas e o contato com objetos cortantes.
10. Não expor o móvel a calor excessivo (luz solar direta), ou umidade elevada.
11. Para limpeza use um pano macio seco ou ligeiramente umedecido com água. Não use agentes de limpeza ou abrasivos.

## SAFETY INFORMATION

1. This package contains small parts, keep away from children until the product is assembled.
2. The instructions are generic, the figures may vary.
3. Read all instructions carefully before starting assembly.
4. Separate and store the ID tag.
5. Check if the volumes and quantities of pieces described in the manual are correct.
6. Identify the pieces and separate accessories.
7. The assembly of the product shall be made on a clean and flat surface. We recommend using the package itself to cover the floor in order not to damage the product.
8. Reserve a specific area to assembly the product.
9. Avoid shocks and contact with sharp objects.
10. Do not expose the furniture to excessive heat (direct sunlight), or high humidity.
11. For cleaning use a dry soft cloth or slightly moistened with water. Do not use cleaning agents or abrasives

## INFORMACIÓN DE SEGURIDAD

1. Este paquete contiene piezas pequeñas, mantenga lejos de los niños hasta que el producto esté montado.
2. Las instrucciones son genéricas, los dibujos pueden variar.
3. Lea todas las instrucciones con cuidado antes de empezar el montaje.
4. Separar y almacenar la etiqueta de identificación.
5. Verifique si los volúmenes y cantidades de las piezas descritas en el manual estan correctas.
6. Identificar las piezas y separar los accesorios.
7. El montaje del producto se efectuará sobre una superficie limpia y plana. Se recomienda usar el propio paquete para cubrir el suelo con el fin de no dañar el producto.
8. Reserve una área específica para el montaje del producto.
9. Evitar los golpes y el contacto con objetos afilados.
10. No exponga el mueble a un calor excesivo (luz solar directa), o alta humedad.
11. Para la limpieza utilice un paño suave y seco o ligeramente humedecido con agua. No utilice productos de limpieza o abrasivos

## PASSO / STEP / PASO 8

Fixe as peças N°11 e 12 nas peças N°10 e 13 utilizando utilizando 'C'.  
Fixe as corredeiras 'U' utilizando 'E'.

*Fix the pieces N°11 and 12 on the pieces N°10 and 13 using 'C'.  
Fix 'U' using and 'E'.*

*Fije las piezas N°10 y 12 en las piezas N°10 y 13 utilizando 'C'.  
Fije 'U' utilizando 'E'.*

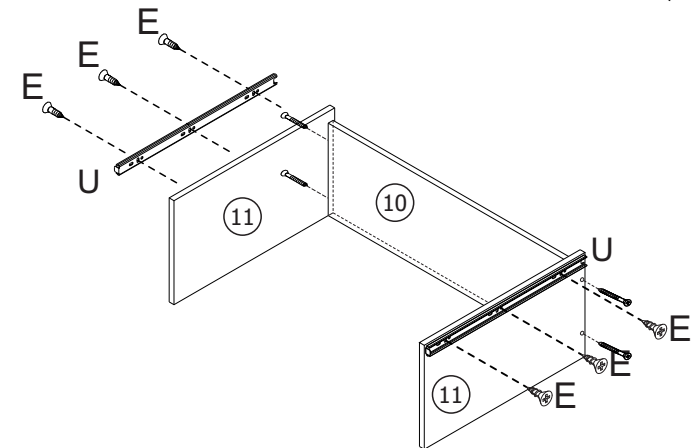
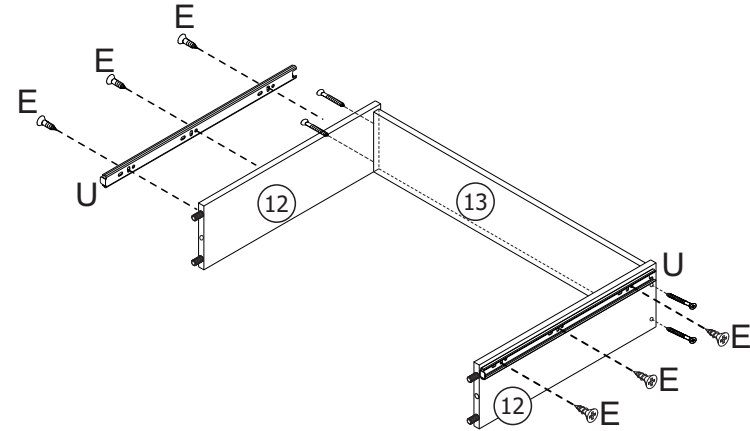

<b>C</b>	16 und.
	Parafuso 4,0 x 40 CC Screw 4,0 x 40 CC Tornillo 4,0 x 40 CC
<b>E</b>	24 und.
	Parafuso 3,5 x 12 CC Screw 3,5 x 12 CC Tornillo 3,5 x 12 CC
<b>U</b>	08 und.
	Corrediza Telescópica 400mm Telescopic Sliding Rail 400mm Rieles Telescópicos 400mm

### PASSO / STEP / PASO 6

Fixe os fundos N°15 e 16 utilizando 'J' e 'S'.  
Encaixe 'V' entre as peças N°16.

Fix the pieces N°15 and 16 using 'J' and 'S'.  
Fitting 'V' between pieces N°16.

Fije las piezas N°15 y 16 utilizando 'J' y 'S'.  
Encaje 'V' entre las piezas N°16.

<b>J</b>	32 und.
	Cavilha 6 x 30 Dowel 6 x 30 Clavija 6 x 30
<b>S</b>	04 und.
	Chapa Junção Fundo Insulation Pins Chapa Prendedora
<b>V</b>	01 und.
	Perfil H 860mm Profile H 860mm Perfil H 860mm

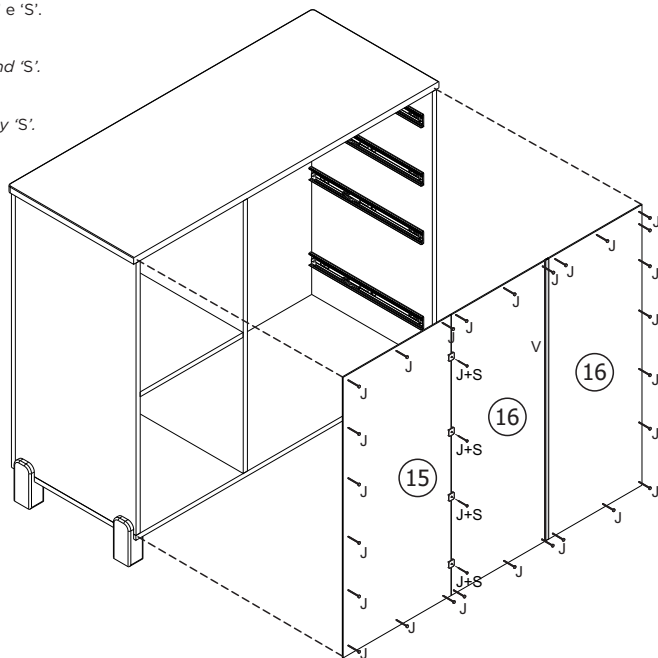

### PASSO / STEP / PASO 7

Fixe 'L' no tampo N°01 utilizando 'F'.  
Fixe 'N' na parede e trave na cómoda utilizando 'B'.

Fix 'L' on the piece N°01 using 'F'.  
Fix 'N' on the wall and lock on the dresser using 'B'.

Fije 'L' en la pieza N°01 utilizando 'F'.  
Fije 'N' en la pared y traba en la cómoda utilizando 'B'.

<b>B</b>	02 und.
	Parafuso 5,0 x 60 CC Screw 5,0 x 60 CC Tornillo 5,0 x 60 CC
<b>F</b>	02 und.
	Parafuso 4,0 x 16 CC Screw 4,0 x 16 CC Tornillo 4,0 x 16 CC
<b>L</b>	02 und.
	Cantoneira Metálica Metallic Corner Brace Cantoneira Metálica
<b>N</b>	02 und.
	Bucha Ivasa 8mm Ivasa Bushing 8mm Casquillo Ivasa 8mm

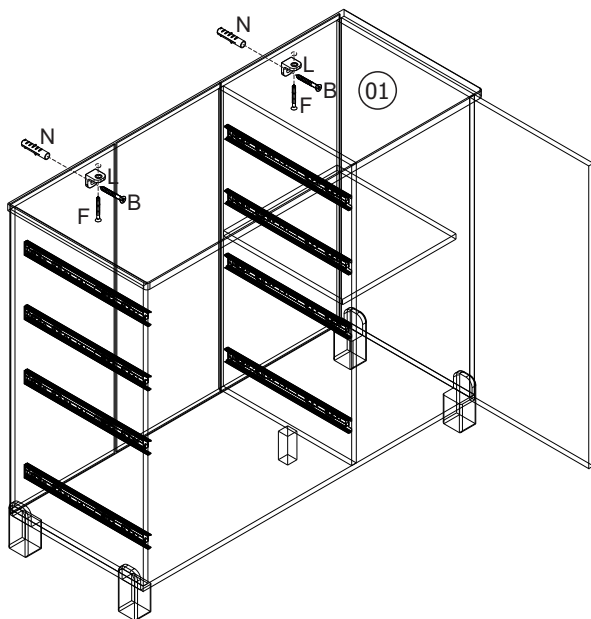

10

## FERRAGENS HARDWARE / HERRAJES

<b>A</b>	32 und.	<b>B</b>	02 und.	<b>C</b>	16 und.	<b>D</b>	52 und.	<b>E</b>	64 und.	<b>F</b>	06 und.
	Cavilha 6 x 30 Dowel 6 x 30 Clavija 6 x 30		Parafuso 5,0 x 60 CC Screw 5,0 x 60 CC Tornillo 5,0 x 60 CC		Parafuso 4,0 x 40 CC Screw 4,0 x 40 CC Tornillo 4,0 x 40 CC		Parafuso 3,0 x 20 CC Screw 3,0 x 20 CC Tornillo 3,0 x 20 CC		Parafuso 3,5 x 12 CC Screw 3,5 x 12 CC Tornillo 3,5 x 12 CC		Parafuso 4,0 x 16 CC Screw 4,0 x 16 CC Tornillo 4,0 x 16 CC
<b>G</b>	12 und.	<b>H</b>	05 und.	<b>I</b>	26 und.	<b>J</b>	32 und.	<b>K</b>	04 und.	<b>L</b>	02 und.
	Parafuso 4,0 x 30 Franjeado Screw 4,0 x 30 Franjeado Tornillo 4,0 x 30 Franjeado		Parafuso 7,0 x 50 Estrutural Structural Screw 7,0 x 50 Tornillo 7,0 x 50 Estrutural		Parafuso Minifix Minifix Screw Tornillo Minifix		Prego 8 x 8 Nail 8 x 8 Clavo 8 x 8		Cantoneira Triangular Triangle Corner Brace Cantoneira Triangular		Cantoneira Metálica Metallic Corner Brace Cantoneira Metálica
<b>M</b>	26 und.	<b>N</b>	02 und.	<b>O</b>	06 und.	<b>P</b>	28 und.	<b>R</b>	05 und.	<b>S</b>	04 und.
	Tambor Minifix Minifix Nut Tambor Minifix		Bucha Ivasa 8mm Ivasa Bushing 8mm Casquillo Ivasa 8mm		Puxador Handle Tirador		Tampa Adesiva 18mm Branca Adhesive Label 18mm White Tapa Adhesiva 18mm Blanco		Pés de Madeira Wood Feet Pies de Madera		Chapa Junção Fundo Insulation Pins Chapa Prendedora
<b>KIT CORREDIÇA KIT SLIDING RAILS KIT RIELES</b>		<b>T</b>	08 und.	<b>U</b>	08 und.	<b>V</b>	01 und.	<b>W</b>	01 und.	<b>X</b>	02 und.
			Corrediça Telescópica 400mm Telescopic Sliding Rail 400mm Rieles Telescópicos 400mm		Corrediça Telescópica 400mm Telescopic Sliding Rail 400mm Rieles Telescópicos 400mm		Perfil H 860mm Profile H 860mm Perfil H 860mm		Etiqueta Móveis Estrela Móveis Estrela Label Etiqueta Móveis Estrela		Calço Dobradiça Shins Hinge Catzón Bisagra
<b>Y</b>	02 und.										
	Dobradiça 26mm Hinge 26mm Bisagra 26mm										

## FERRAGENS ESCALA REAL REAL SIZE / TAMAÑO REAL

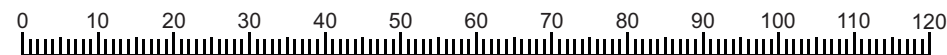
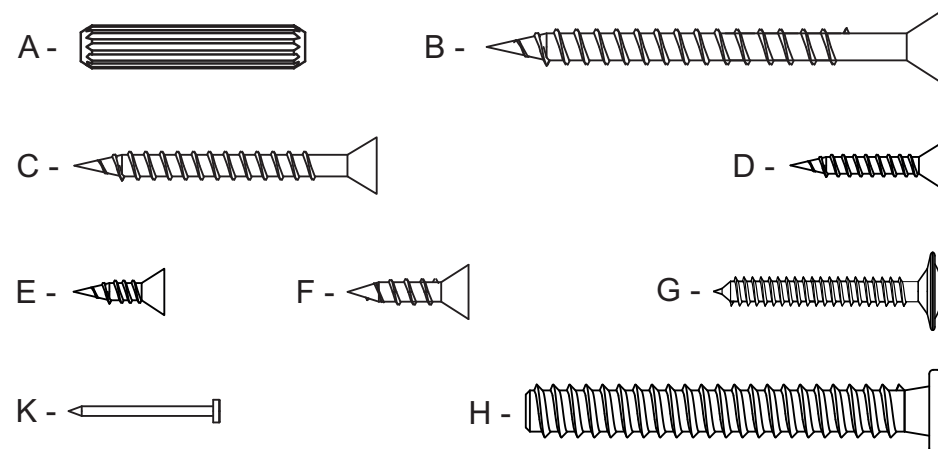

Medidas em mm

03

IDENTIFICAÇÃO DAS PEÇAS  
IDENTIFICATION OF PARTS / IDENTIFICACIÓN DE LAS PIEZAS

CÓD.	IDENTIFICAÇÃO DAS PEÇAS	IDENTIFICATION OF PARTS	IDENTIFICACIÓN DE LAS PIEZAS	QTD
01	Tampo	Surface	Tapa	01
02	Prateleira	Shelf	Repisa	01
03	Lateral Direita	Right side	Lateral derecha	01
04	Lateral Esquerda	Left side	Lateral izquierda	01
05	Divisória	Partition	Separador	01
06	Frente de Gaveta Pequena	Smaller Drawer Front	Frente del Cajón Menor	03
07	Frente de Gaveta Grande	Larger Drawer Front	Frente del Cajón Mayor	01
08	Porta	Door	Puerta	01
09	Base	Base	Base	01
10	Contra Fundo Grande	Larger Drawer Back	Trasera del Cajón Mayor	01
11	Lateral de Gaveta Grande	Larger Drawer Side	Lado del Cajón Mayor	02
12	Lateral de Gaveta Pequena	Smaller Drawer Side	Lado del Cajón Menor	06
13	Contra Fundo Pequeno	Smaller Drawer Back	Trasera del Cajón Menor	03
14	Fundo da Gaveta	Drawer Bottom	Fondo del Cajón	04
15	Fundo Porta	Door Bottom	Fondo de la Puerta	01
16	Fundo Gaveteiro	Back Bottom	Fondo Trasero del Cajón	02

ASSISTÊNCIA TÉCNICA

Ao solicitar assistência técnica, informe o número da peça, nome e cor do produto e a data de fabricação do lote que se encontra carimbado na peça nº16.

TECHNICAL ASSISTANCE

When request the technical assistance, inform the number of the piece name and color of the product and also the batch manufacturing date, that is stamped on the piece nº16.

ASISTENCIA TÉCNICA

Al solicitar la asistencia técnica, informe el número de la pieza, el nombre y el color del producto y también la fecha de fabricación del lote, que se estampa en la pieza nº16.



04

PASSO / STEP / PASO 4

Fixe as corredeiras 'T' utilizando 'E'

Fix 'T' using 'E'

Fije 'T' utilizando 'E'

<b>E</b>	32 und.
	Parafuso 3,5 x 12 CC Screw 3,5 x 12 CC Tornillo 3,5 x 12 CC
<b>T</b>	08 und.
	Correção Telescópica 400mm Telescopic Sliding Rail 400mm Rieles Telescópicos 400mm

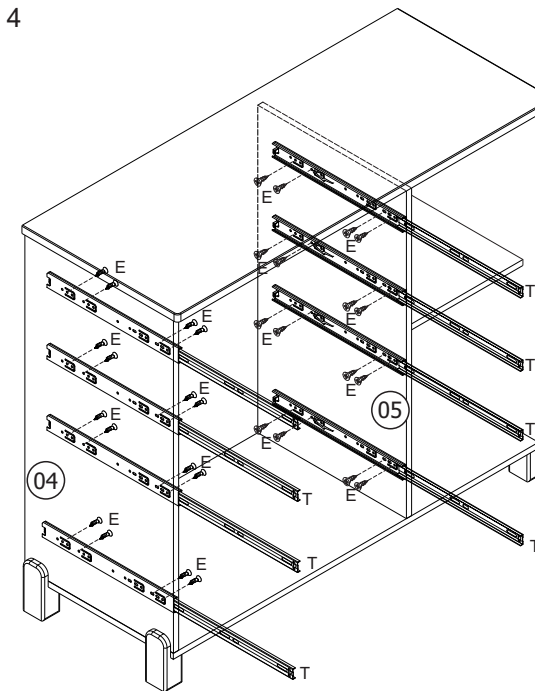







PASSO / STEP / PASO 5

Fixe os calços 'X' na peça N°03 utilizando 'E' e as dobradiças 'Y' na peça N°08 utilizando 'E'.  
Fixe o puxador 'O' na peça N°08 utilizando 'G'.  
Cole a etiqueta 'W'.

Fix 'X' on the piece N°03 using 'E' and fix 'Y' on the piece N°08 using 'E'.  
Fix 'O' on the piece N°08 using 'G'.  
Paste 'W'.

Fije 'X' en la pieza N°03 utilizando 'E' y fije 'Y' en la pieza N°08 utilizando 'E'.  
Fije 'O' en la pieza N°08 utilizando 'G'.  
Pegue 'W'.

<b>E</b>	08 und.	<b>O</b>	01 und.
	Parafuso 3,5 x 12 CC Screw 3,5 x 12 CC Tornillo 3,5 x 12 CC		Puxador Handle Tirador
<b>X</b>	02 und.	<b>G</b>	02 und.
	Calço Dobradiça Shins Hinge Calzón Bisagra		Parafuso 4,0 x 30 Franjeado Screw 4,0 x 30 Franjeado Tornillo 4,0 x 30 Franjeado
<b>Y</b>	02 und.	<b>W</b>	01 und.
	Dobradiça 26mm Hinge 26mm Bisagra 26mm		Etiqueta Móveis Estrela Móveis Estrela Label Etiqueta Móveis Estrela

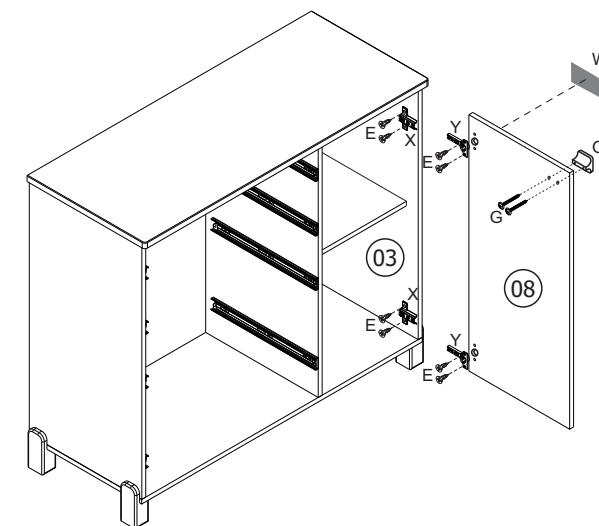

09

## PASSO / STEP / PASO 2

Fixe os pés 'R' na peça N° 09 utilizando parafuso 'H'.

Fix the feet 'R' on the piece N° 09 using 'H'.

Fije los pies 'R' en la pieza N° 09 utilizando 'H'.

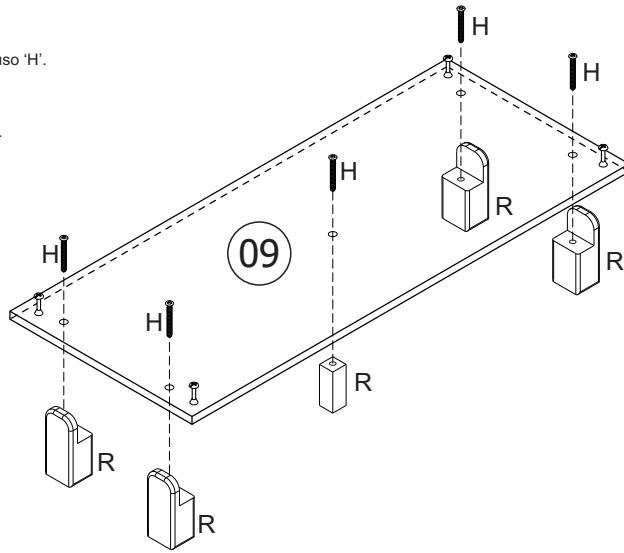
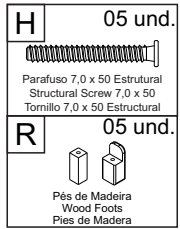

## PASSO / STEP / PASO 3

Una as peças N°01, 02, 03, 04, 05 e 09.

Em seguida cole a 'P'.

Fit the pieces N°01, 02, 03, 04, 05 and 09.  
Then paste 'P'.

Encaje las piezas N°01, 02, 03, 04, 05 y 09  
Después pegue 'P'.

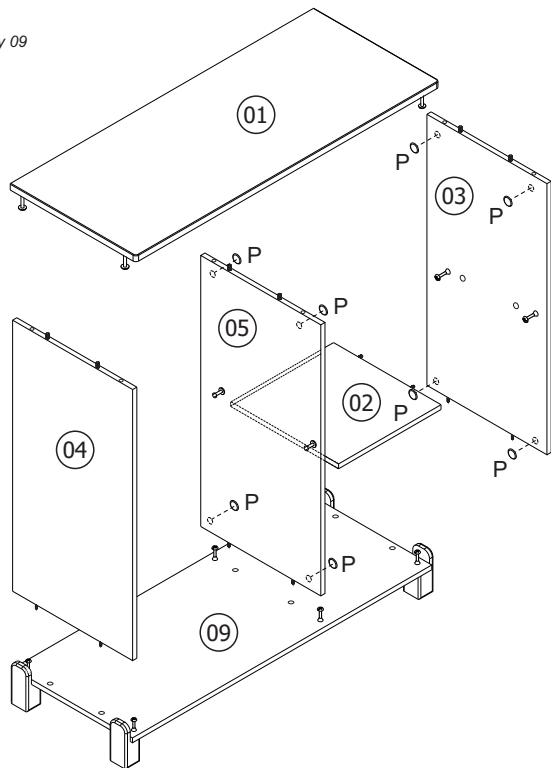
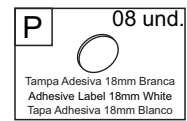

## IDENTIFICAÇÃO DAS PEÇAS IDENTIFICATION OF PARTS / IDENTIFICACIÓN DE LAS PIEZAS

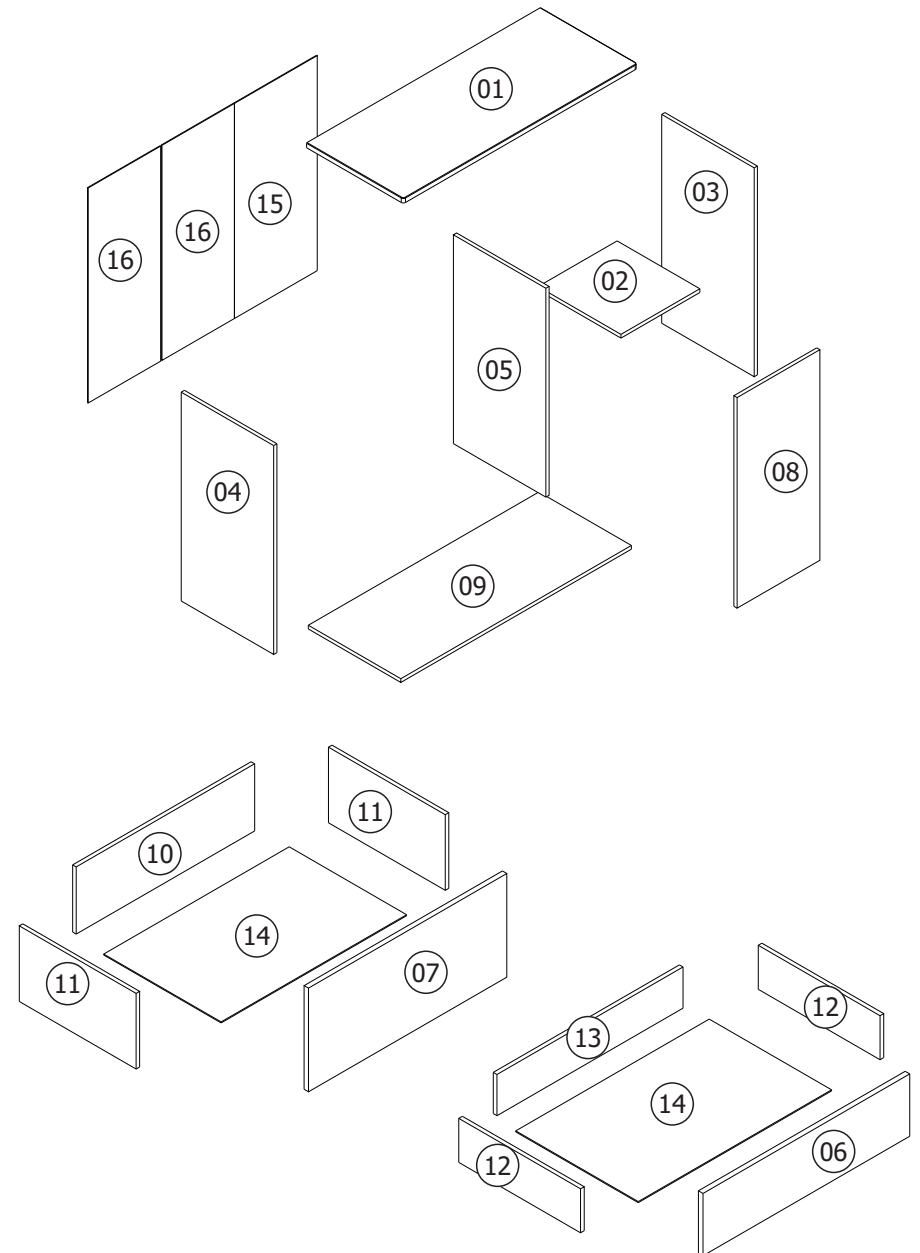

**DIMENSÕES PRODUTO MONTADO / PESO SUPORTADO**  
**DIMENSIONS ASSEMBLED / SUPPORTED WEIGHT**  
**DIMENSIONES PRODUCTO ARMADO / PESO SUPORTADO**

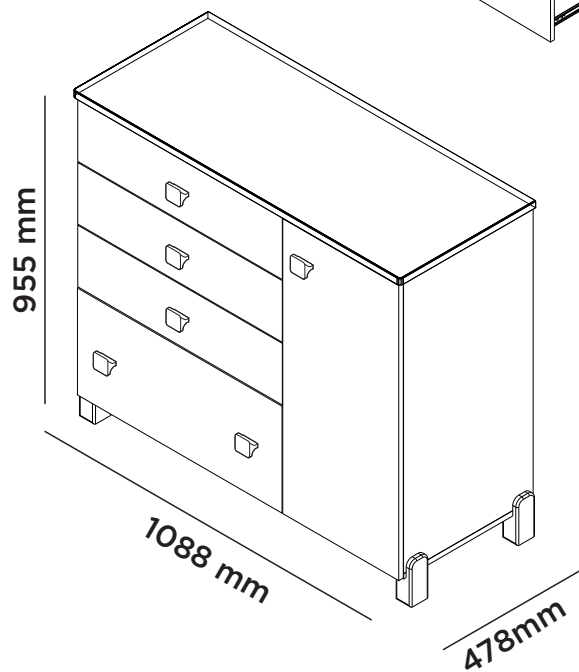
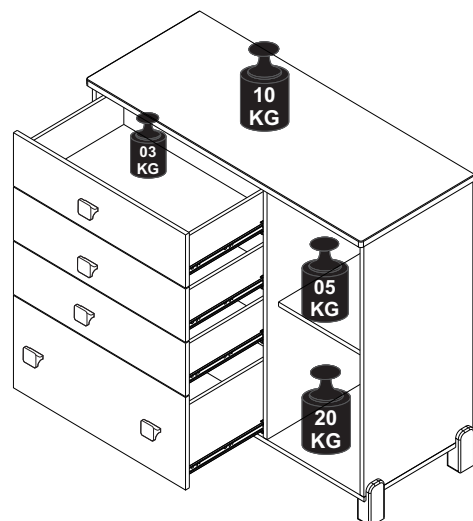

06

**MONTAGEM DO PRODUTO / PRODUCT ASSEMBLY / MONTAJE DEL PRODUCTO**

**PASSO / STEP / PASO 1**

Prepare as peças N°01, 02, 03, 04, 05, 06, 07, 09, 11 e 12 utilizando 'A', 'I' e 'M'.

Prepare the pieces N°01, 02, 03, 04, 05, 06, 07, 09, 11 and 12 using 'A', 'I' and 'M'.

Preparare las piezas N°01, 02, 03, 04, 05, 06, 07, 09, 11 y 12 utilizando 'A', 'I' y 'M'.

<b>A</b>	32 und.	<b>I</b>	26 und.
	Cavilha 6 x 30 Dowel 6 x 30 Clavija 6 x 30		Parafuso Minifix Minifix Screw Tornillo Minifix
		<b>M</b>	26 und.
			Tambor Minifix Minifix Nut Tambor Minifix

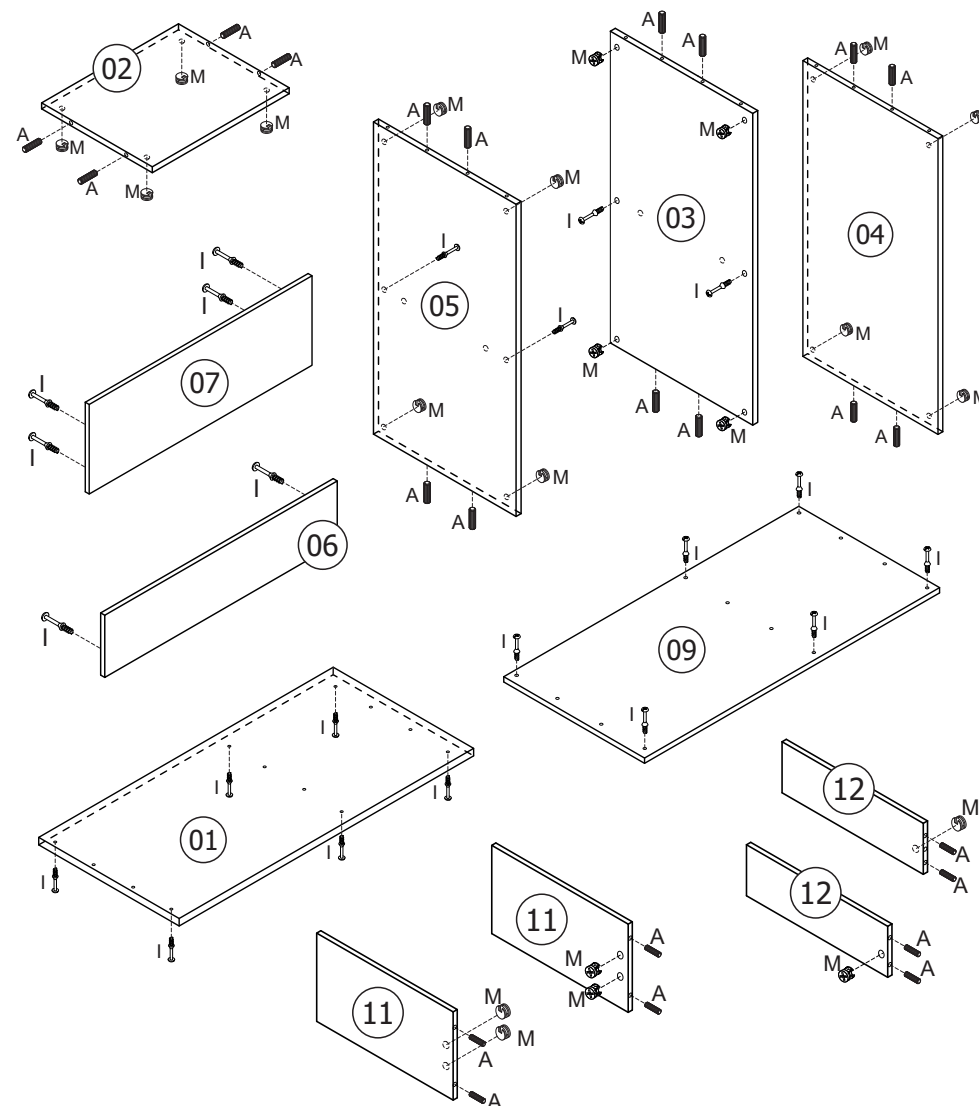

07