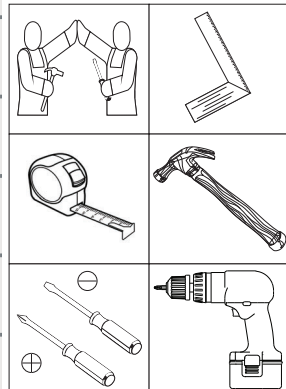
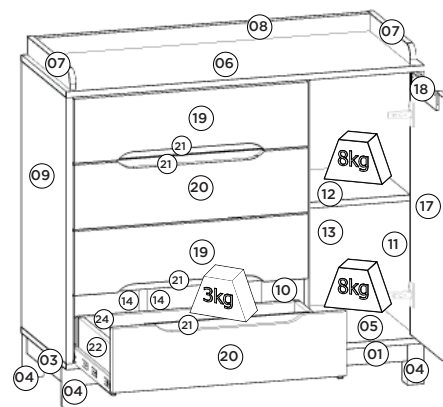
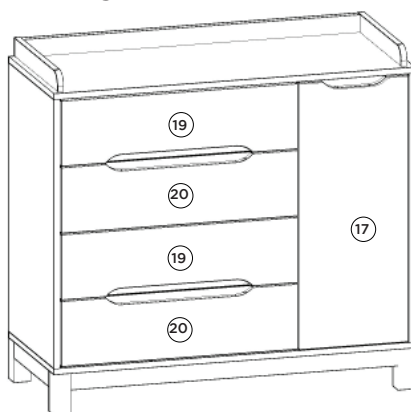

HENNInd. e Com. de Móveis Henn
Mondai - SC - Brasil

☎+55 49 3674.3500

📧@moveishenn
www.henn.com.br**INSTRUÇÕES DE MONTAGEM**INSTRUCCIONES DE MONTAJE
ASSEMBLY INSTRUCTIONS**CÔMODA ALEGRIA 01 PORTA 04 GAVETAS | CÔMODA ALEGRIA 01 PUERTA 4 CAJONES |
ALEGRIA DRESSER 01 DOOR 04 DRAWERS**I713-05 Branco HP
I713-131 CinzaRequisitos para montagem
Requisitor para la montaje
Assembly RequirementsImagens meramente ilustrativas
Imágenes meramente ilustrativas
Images for illustration onlyPesos máximos recomendados com carga distribuída
Peso máximo recomendado con la carga distribuída
Recommended maximum weights with evenly distributed.

Lista de Peças | Lista de piezas | List of parts

Item	Caixa Caja Box	Qtd Ctd Qty	Descrição Descripción Description	Medidas (mm) Dimensions (mm) Size (measure- ments) (mm)
01	1/1	01	Rodapé frontal delante de pie de página Front footer	888x45x15
02	1/1	01	Rodapé traseiro Pie de página trasera Rear footer	888x45x15
03	1/1	02	Rodapé lateral Pie de página lado Side Footer	318x45x15
04	1/1	04	Pé Pie Foot	110x45x45
05	1/1	01	Base Base Base	980x410x15
06	1/1	01	Tampo Tapa Top	980x410x15
07	1/1	02	Moldura Lateral Marco lateral Side Frame	390x50x15
08	1/1	01	Moldura Superior Marco Superior Upper Frame	917x48x15
09	1/1	01	Lateral esquerda Lateral izquierda Left side	722x410x15
10	1/1	01	Divisão División Division	722x395x15
11	1/1	01	Lateral direita Lateral derecha Right side	722x410x15
12	1/1	01	Prateleira Estante Shelf	335x293x15
13	1/1	01	Fundo Fondo Fund	750x312x3
14	1/1	02	Fundo Cru Fondo crudo Raw Bottom	750x329x3
15	1/1	01	Ripa lateral menor Listón lateral más pequeño Smaller side lath	720x60x9
16	1/1	01	Ripa lateral Listón lateral Side lath	720x70x9
17	1/1	01	Porta Puerta Door	715x295x15
18	1/1	01	Aplique Porta Aplicar puerta Apply Door	250x45x6
19	1/1	02	Frente de gaveta superior Frente del cajón superior Top drawer front	640x175x15
20	1/1	02	Frente de gaveta inferior Frente del cajón inferior Lower drawer front	640x175x15
21	1/1	04	Aplique Gaveta Aplicar cajón Apply Drawer	475x45x6
22	1/1	08	Lado de gaveta Lado del cajón Side of drawer	350x110x15
23	1/1	04	Fundo de gaveta Fondo del cajón Drawer bottom	587x361x3
24	1/1	04	Ripa de trás Malla detrás Rear lath	606x110x15

AVISO

Para limpeza de seu móvel, use uma flanela seca ou umedecida, e não utilize produtos químicos que possam danificar seu produto.

SISTEMA DE MONTAGEM

O sistema de montagem dos produtos, funciona de acordo com a ordem crescente dos números indicados no desenho. Ex: 01, 02, 03, 04... até a conclusão da montagem.

ADVERTENCIA

Para limpieza de su móvil, use una flanela seca o húmeda, y no utilice productos químicos que puedan dañar su producto.

SISTEMA DE MONTAJE

El sistema de montaje de los productos funciona de acuerdo con el orden creciente de los números indicados en el dibujo. Ej.: 01, 02, 03, 04... hasta la conclusión del montaje.

NOTICE

To clean your furniture, use a dry or wet cloth, and do not use chemicals that may damage your product.

ASSEMBLY SYSTEM

The products' assembly system works according to the increasing order of the indicated numbers. For example: 01, 02, 03, 04 ... to the end of the assembly.

Ferragens | Herrajes | Hardware

A 21x Parafuso 3,5x40mm CHT. Tornillo 3,5x40mm CHT. Screw 3,5x40mm CHT.	B 46x Parafuso 3,5x14mm FLA. Tornillo 3,5x14mm FLA. Screw 3,5x14mm FLA.	C 60x Parafuso 3,5x12mm CHT. Tornillo 3,5x12mm CHT. Screw 3,5x12mm CHT.	D 08x Parafuso 3,0x30mm CHT. Tornillo 3,0x30mm CHT. Screw 3,0x30mm CHT.	E 08x Parafuso 3,0x16mm CHT. Tornillo 3,0x16mm CHT. Screw 3,0x16mm CHT.	F 54x Cavilha 8x25mm Cinta 8x25mm Dowel 8x25mm	G 42x Prego 10x10mm Clavo 10x10mm Nail 10x10mm
H 08x Fixador de fundos Fijador de fondos Bottom fixer	I 11x Cantoneira plástica Cantonera plástica Plastic angle brackets	J 08x Cantoneira suporte triangular Cantonera soporte triangular Triangle support angle	K 06x Parafuso 3,0x20mm CHT. Tornillo 3,0x20mm CHT. Screw 3,0x20mm CHT.	L 08x Cantoneira de metal Soporte de metal Metal bracket	M 01x Parafuso 5,0x50mm FLA. Tornillo 5,0x50mm FLA. Screw 5,0x50mm FLA.	N 04x Parafuso minifix Tornillo minifix Minifix bolt
O 04x Tambor minifix Tambor minifix Minifix drum	P 02x Calço metal 12mm Calzado metálico 12mm 12mm metal shim	Q 02x Dobradilha metal 26mm Bisagra de metal 26mm 26 mm metal hinge	R 01x Buchsa plástica 8mm Buchsa de plástico 8mm 8mm plastic bushing	S 01x Suporte de fixação Soporte de fijación Mounting bracket	T 04x Corredilha telescópica Corredera telescópica Telescopic slide	U 02x Sachê de cola Bolsa de pegamento Glue bag
V 02x Giz de correção Tiza de corrección Chalk of correction	W 01x Perfil "I" 735mm Perfil "I" 735mm Profile "I" 735mm	X 05x Adesivo tapa parafuso 10mm Adhesivo tapón de tornillo 10mm Bolt cover adhesive 10mm	Y 02x Adesivo tapa parafuso 17mm Adhesivo tapón de tornillo 17mm Bolt cover adhesive 17mm	Z 01x Etiqueta resinada Henn Etiqueta resinada Henn Henn resin label		

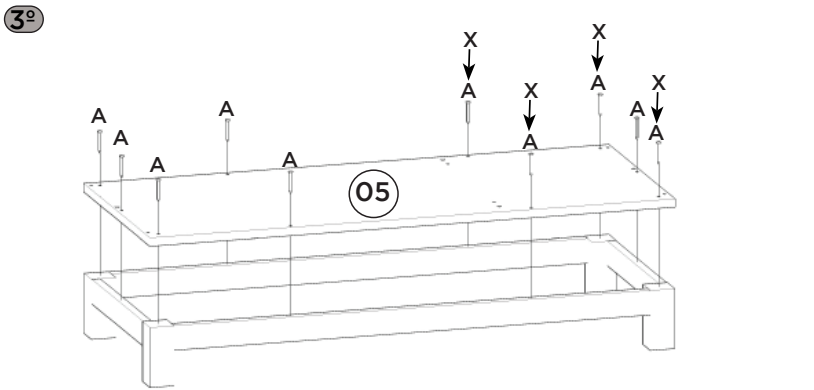
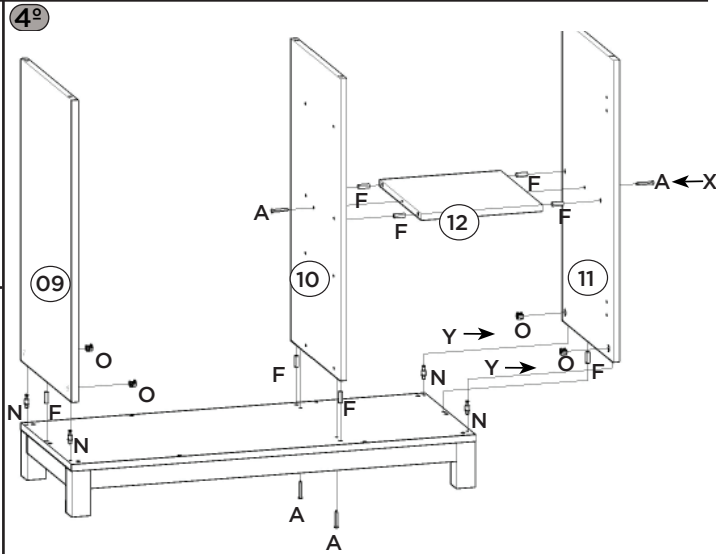
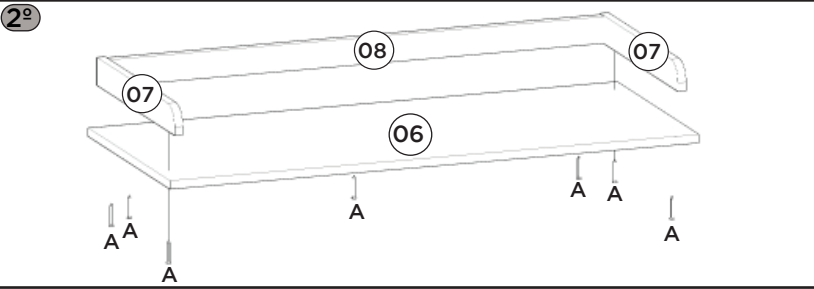
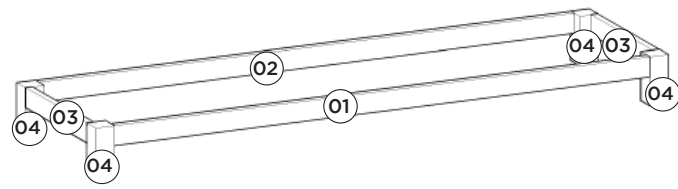
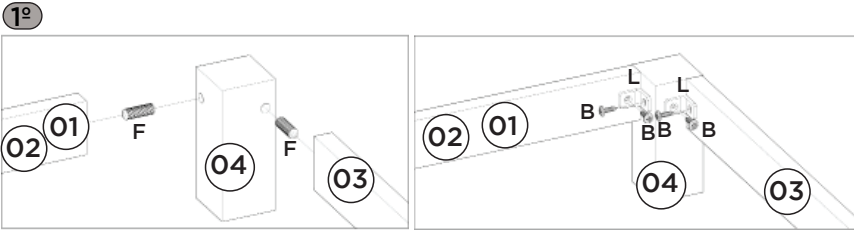

- Video: Dicas para fixar o Minifix
- Video: Consejos para arreglar Minifix
- Video: Tips for Fixing Minifix

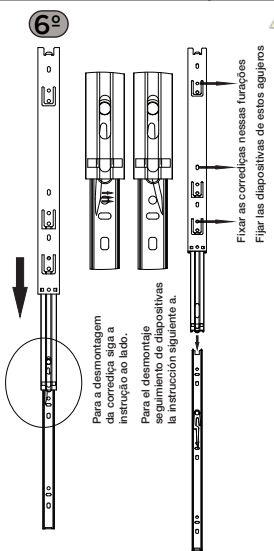
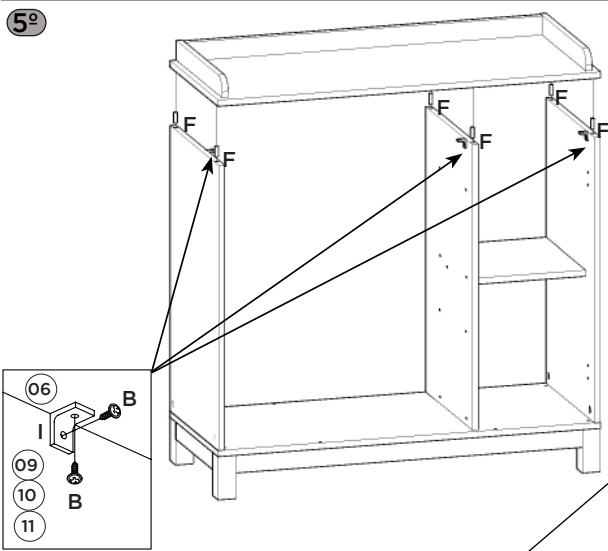

Imprescindible a fijación del producto en la pared, a não colocação destas ferragens para fixação (M, B, R e S), poderá permitir que o produto vire, causando acidente.

Es imprescindible la fijación del producto en la pared, la no colocación de estos herrajes para fijación (M, B, R y S), podrá permitir que el producto se vuelva, causando accidente.

Indispensable to fix the product on the wall, not the placement of these attachment fittings (M, B, R and S) may allow the product to turn, causing an accident.

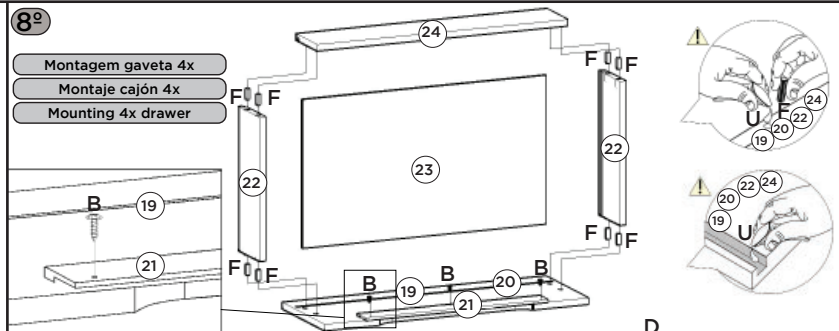
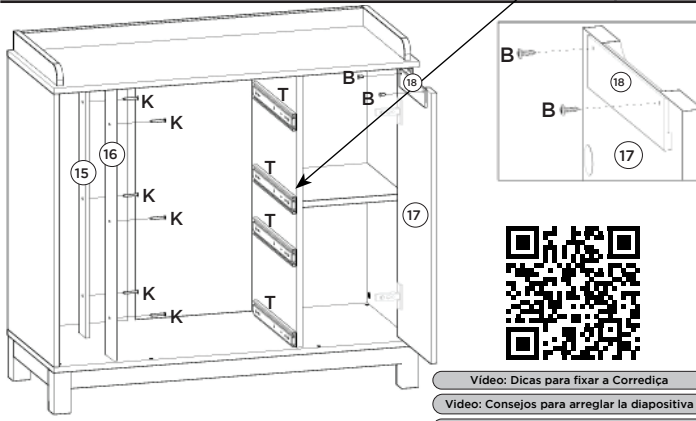
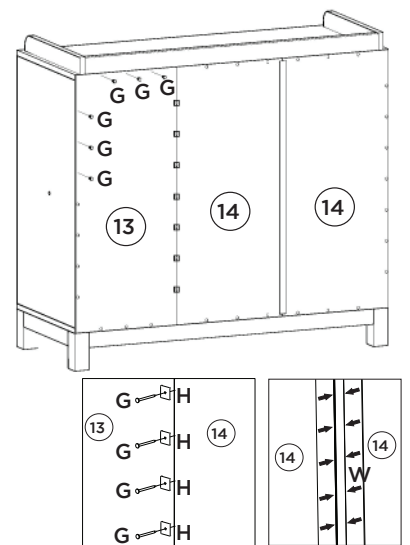

- Montagem gaveta 4x
- Montaje cajón 4x
- Mounting 4x drawer



- Video: Dicas para fixar a Corrediça
- Video: Consejos para arreglar la diapositiva
- Video: Tips for Fixing the Slide

