

MONTAGEM DO PRODUTO

PRODUCT ASSEMBLY / MONTAJE DEL PRODUCTO

PASSO / STEP / PASO 5

Fixe 'N' no tampo N°01 utilizando 'E'.
Fixe 'P' na parede e trave na cómoda utilizando 'B' e 'N'.

Fix 'N' on the piece N°01 using 'E'.
Fix 'P' on the wall and lock on the dresser using 'B' and 'N'.

Fije 'N' en la pieza N°01 utilizando 'E'.
Fije 'P' en la pared y traba en la cómoda utilizando 'B' y 'N'.

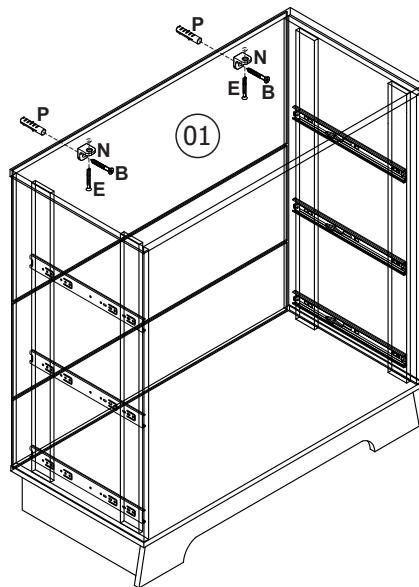

B 02 und.

Parafuso 5,0 x 50 CC
Screw 5,0 x 50 CC
Tornillo 5,0 x 50 CC

N 02 und.

Cantoneira Metálica
Metallic Corner Brace
Cantenera Metálica

P 02 und.

Bucha Ivasa 8mm
Ivsa Bushing 8mm
Casquillo Ivasa 8mm

E 02 und.

Parafuso 3,5 x 12 CC
Screw 3,5 x 12 CC
Tornillo 3,5 x 12 CC

PASSO / STEP / PASO 6

Fixe as peças N°10 e 12 nas peças N°09 e 11 utilizando 'C'.
Fixe as peças N°05 e 06 nas peças N°09 e 11 utilizando 'J', 'M' e 'F'.
Fixe os fundos N°13 e as corredeiras 'U' utilizando 'D' e 'E'.
Fixe os puxadores 'V' utilizando 'H'.
Cole 'R' conforme mostra abaixo.

Fix the pieces N°10 and 12 on the pieces N°09 and 11 using 'C'.
Fix the pieces N°05 and 06 on the pieces N°09 and 11 using 'J', 'M' and 'F'.
Fix the piece N°13 and 'U' using 'D' and 'E'. Fix 'V' using 'H'.
Paste 'R'

Fije las piezas N°10 y 12 en las piezas N°09 y 11 utilizando 'C'.
Fije las piezas N°05 y 06 en las piezas N°09 y 11 using 'J', 'M' y 'F'.
Fije la pieza N°13 y 'U' utilizando 'D' y 'E'. Fije 'V' utilizando 'H'.
Pegue 'R'.

C 12 und. Parafuso 4,0 x 40 CC Screw 4,0 x 40 CC Tornillo 4,0 x 40 CC	D 39 und. Parafuso 3,0 x 20 CC Screw 3,0 x 20 CC Tornillo 3,0 x 20 CC	E 18 und. Parafuso 3,5 x 12 CC Screw 3,5 x 12 CC Tornillo 3,5 x 12 CC
F 06 und. Parafuso 4,0 x 16 CC Screw 4,0 x 16 CC Tornillo 4,0 x 16 CC	H 06 und. Parafuso 4,0 x 25 Franjeado Screw 4,0 x 25 Franjeado Tornillo 4,0 x 25 Franjeado	M 06 und. Cantoneira Triangular Triangle Corner Brace Cantenera Triangular
R 20 und. Tampa Adesiva 18mm Branca Adhesive Label 18mm White Tapa Adhesiva 18mm Blanco	U 06 und. Corredeira Telescópica 400mm Telescopic Sliding Rail 400mm Rieles Telescópicos 400mm	V 06 und. Puxador AL AL Handle Tirador AL

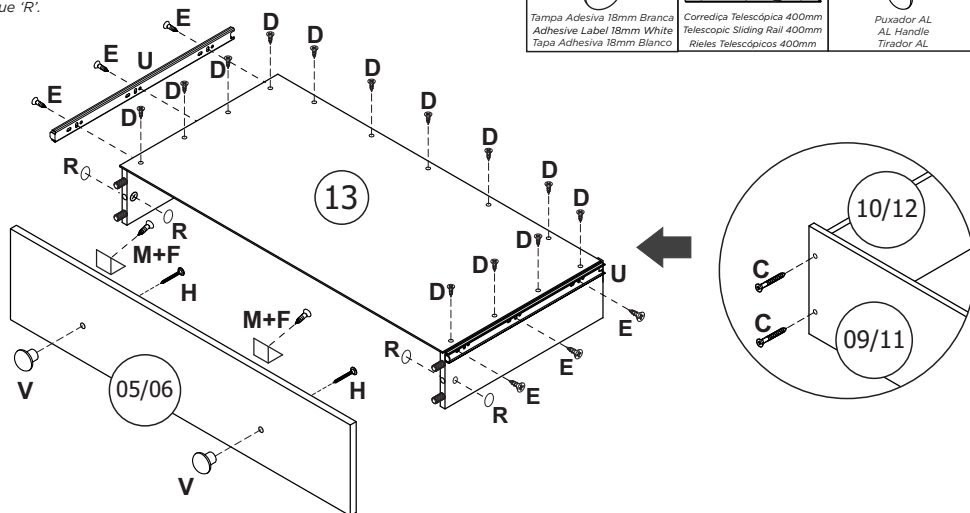

973 mm

450 mm

905mm

MANUAL DE INSTRUÇÕES

MANUAL DE INSTRUCCIONES
INSTRUCTION MANUAL

CERTIFICADO
90
dias
GARANTIA

CÔMODA CARÍCIA S/PT CR8A
CR8A CARÍCIA S/PT DRESSER
CÓMODA CARÍCIA S/PT CR8A

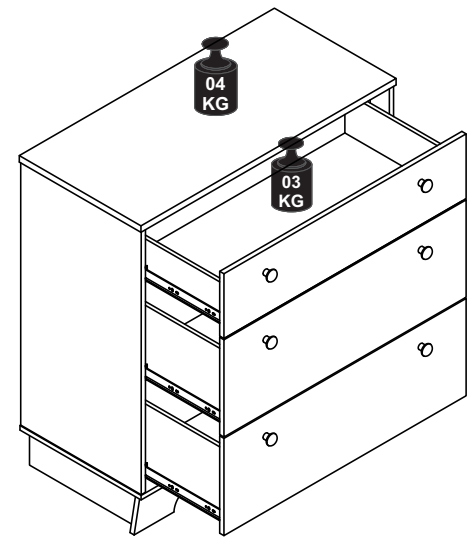
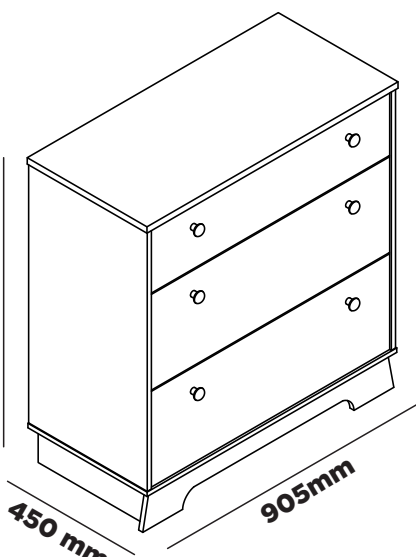

Móveis Estrela
SUA CASA, SEU ESTILO

M.E. GONÇALVES
INDÚSTRIA DE MÓVEIS LTDA.
Avenida Maracanã, 4244 - Parque Industrial
Arapongas - PR - Brasil
Fone: +55 (43) 3274-8800
www.moveisestrela.com.br

"IMAGENS MERAMENTE ILUSTRATIVAS,
SUJEITAS À ALTERAÇÕES SEM PRÉVIO AVISO"



1 Adulto
1 Adult

Pessoas Necessárias para montagem

Necessary people for assembly

Gente necesaria para la asamblea

Ferramentas Necessárias (Não Inclusas)

Tools needed (not included)

Herramientas necesarias (no incluido)



Martelo
Martillo
Hammer



Parafusadeira
Screwdriver
Destornillador



Chave Fenda
Slot Key
Clave de runura



Chave Phillips
Phillips Key
Clave Phillips

INFORMAÇÕES SOBRE SEGURANÇA

1. Esta embalagem contém peças pequenas, mantenha afastada de crianças até que o produto esteja montado.
2. As instruções são genéricas, as figuras podem variar.
3. Leia atentamente todas as instruções antes de iniciar a montagem.
4. Separe e guarde a etiqueta de identificação.
5. Confira se os volumes e quantidades de peças descritos no manual estão corretos.
6. Identifique as peças e separe os acessórios.
7. A montagem do produto deverá ser feita em uma superfície limpa e plana. Aconselhamos utilizar a própria embalagem para forrar o chão a fim de não danificar o produto.
8. Reservar área livre para montagem do produto.
9. Evitar batidas e o contato com objetos cortantes.
10. Não expor o móvel a calor excessivo (luz solar direta), ou umidade elevada.
11. Para limpeza use um pano macio seco ou ligeiramente umedecido com água. Não use agentes de limpeza ou abrasivos.

SAFETY INFORMATION

1. This package contains small parts, keep away from children until the product is assembled.
2. The instructions are generic, the figures may vary.
3. Read all instructions carefully before starting assembly.
4. Separate and store the ID tag.
5. Check if the volumes and quantities of pieces described in the manual are correct.
6. Identify the pieces and separate accessories.
7. The assembly of the product shall be made on a clean and flat surface. We recommend using the package itself to cover the floor in order not to damage the product.
8. Reserve a specific area to assembly the product.
9. Avoid shocks and contact with sharp objects.
10. Do not expose the furniture to excessive heat (direct sunlight), or high humidity.
11. For cleaning use a dry soft cloth or slightly moistened with water. Do not use cleaning agents or abrasives

INFORMACIÓN DE SEGURIDAD

1. Este paquete contiene piezas pequeñas, mantenga alejado de los niños hasta que el producto esté montado.
2. Las instrucciones son genéricas, los dibujos pueden variar.
3. Lea todas las instrucciones cuidadosamente antes de empezar el montaje.
4. Separar y almacenar la etiqueta de identificación.
5. Verifique si los volúmenes y cantidades de las piezas descritas en el manual estan correctas.
6. Identificar las piezas y separar los accesórios.
7. El montaje del producto se efectuará sobre una superficie limpia y plana. Se recomienda usar el propio envase para cubrir el suelo con el fin de no dañar el producto.
8. Reserve una área específica para el montaje del producto.
9. Evitar los golpes y el contacto con objetos afilados.
10. No exponga el mueble a un calor excesivo (luz solar directa), o alta humedad.
11. Para la limpieza utilice un paño suave y seco o ligeramente humedecido con agua. No utilice productos de limpieza o abrasivos

MONTAGEM DO PRODUTO

PRODUCT ASSEMBLY / MONTAJE DEL PRODUCTO

PASSO / STEP / PASO 3

Fixe as corredeiras 'T' utilizando 'E' e 'G'.

Fix 'T' using 'E' and 'G'.

Fije 'T' utilizando 'E' y 'G'.

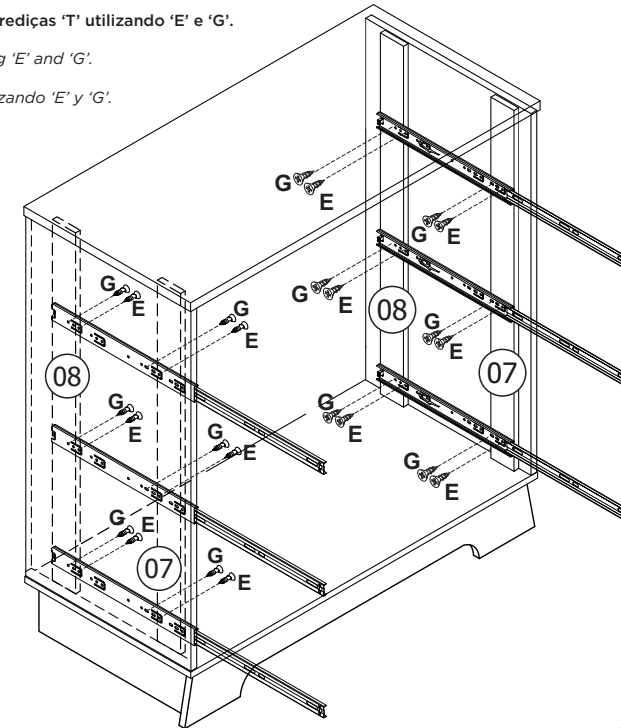

Para efetuar a montagem da corredeira, retirar a peça 'U' da peça 'T' puxando a trava de segurança para baixo.

Unlock the safety lock to fix the sliding rails.

Desbloquee la traba de seguridad para fijar los rieles.

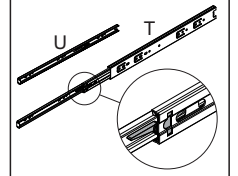

E	12 und.
	Parafuso 3,5 x 12 CC Screw 3,5 x 12 CC Tornillo 3,5 x 12 CC
G	12 und.
	Parafuso 4,0 x 22 CC Screw 4,0 x 22 CC Tornillo 4,0 x 22 CC
T	06 und.
	Corredeira Telescópica 400mm Telescopic Sliding Rail 400mm Rieles Telescópicos 400mm

PASSO / STEP / PASO 4

Fixe os fundos N°14, 15 e 16 utilizando 'K' e 'W'.

Fix the pieces N°14, 15 and 16 using 'K' and 'W'.

Fije las piezas N°14, 15 y 16 utilizando 'K' y 'W'.

K	32 und.
	Prego 8 x 8 Nail 8 x 8 Clavo 8 x 8
W	02 und.
	Perfil H 860mm Profile H 860mm Perfil H 860mm

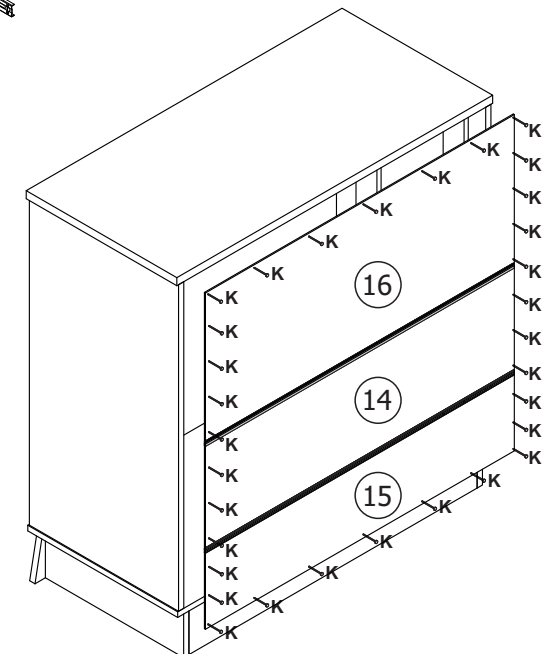

MONTAGEM DO PRODUTO



PRODUCT ASSEMBLY / MONTAJE DEL PRODUCTO

PASSO / STEP / PASO 1

Fixe as peças N°24, 25 e 26 utilizando 'B', 'E' e 'L'.

Fix the pieces N°24, 25 and 26 using 'B', 'E' and 'L'.

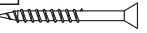
Fije las piezas N°24, 25 y 26 utilizando 'B', 'E' y 'L'.

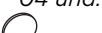
B	04 und.
	Parafuso 5,0 x 50 CC Screw 5.0 x 50 CC Tornillo 5.0 x 50 CC
E	32 und.
	Parafuso 3,5 x 12 CC Screw 3.5 x 12 CC Tornillo 3.5 x 12 CC
L	08 und.
	Cantoneira Bicromatizada Corner Brace Cantoneira Bicromatizada
Q	04 und.
	Tampa Adesiva 12mm Branca Adhesive Label 12mm White Tapa Adhesiva 12mm Blanco

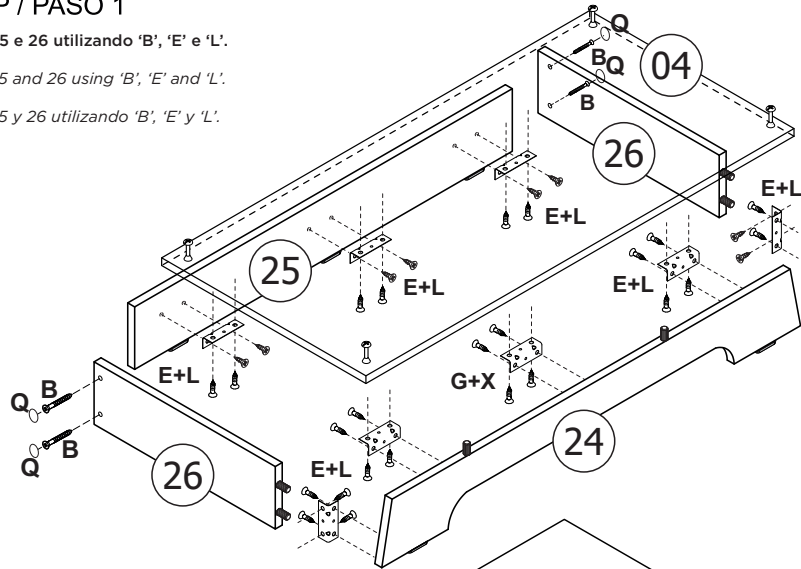

PASSO / STEP / PASO 2

Una as peças N°01, 02, 03 e 04.

Fixe as peças N°07 e 08 seguindo as marcações nas peças N°02 e 03 utilizando 'G'.







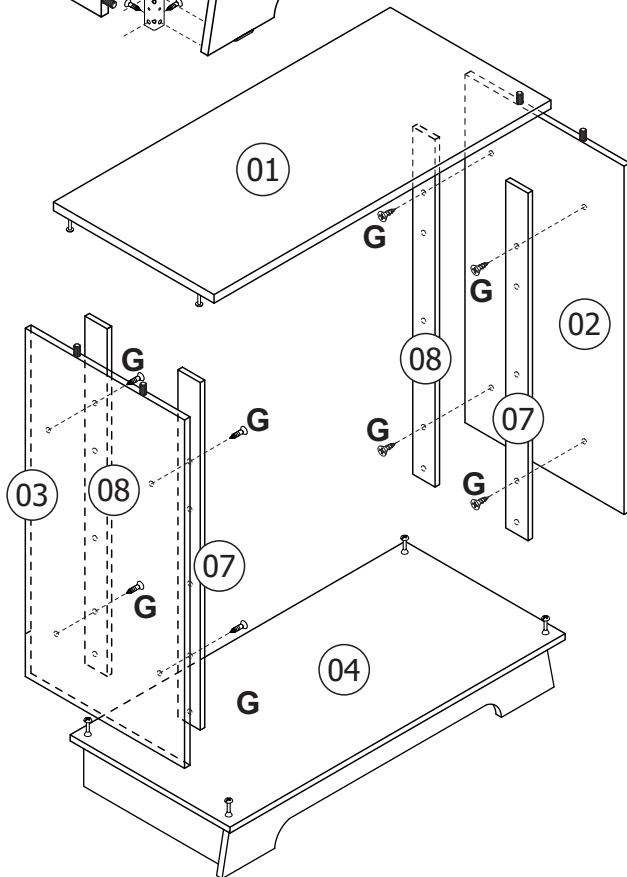





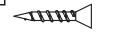

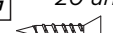
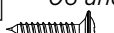
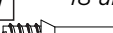
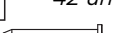
Fit the pieces N°01, 02, 03 and 04.
Fix the pieces N°07 and 08 following the margins on the pieces N°02 and 03 using 'G'.

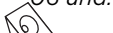
Encaje las piezas N°01, 02, 03 y 04.
Fije las piezas N°07 y 08 siguiendo las marchas en las piezas N°02 y 03 utilizando 'G'.

G	08 und.
	Parafuso 4,0 x 22 CC Screw 4.0 x 22 CC Tornillo 4.0 x 22 CC

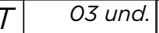
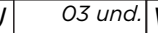

FERRAGENS IRONMONGERY / HERRAJES

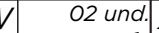
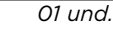
A	26 und.	B	06 und.	C	12 und.	D	39 und.	E	62 und.	F	06 und.
	Cavilha 6 x 30 Dowel 6 x 30 Clavija 6 x 30		Parafuso 5,0 x 50 CC Screw 5.0 x 50 CC Tornillo 5.0 x 50 CC		Parafuso 4,0 x 40 CC Screw 4.0 x 40 CC Tornillo 4.0 x 40 CC		Parafuso 3,0 x 20 CC Screw 3.0 x 20 CC Tornillo 3.0 x 20 CC		Parafuso 3,5 x 12 CC Screw 3.5 x 12 CC Tornillo 3.5 x 12 CC		Parafuso 4,0 x 16 CC Screw 4.0 x 16 CC Tornillo 4.0 x 16 CC
G	20 und.	H	06 und.	J	18 und.	K	42 und.	L	08 und.	M	06 und.
	Parafuso 4,0 x 22 CC Screw 4.0 x 22 CC Tornillo 4.0 x 22 CC		Parafuso 4,5 x 25 Franjeado Screw 4.5 x 25 Franjeado Tornillo 4.5 x 25 Franjeado		Parafuso Minifix Minifix Screw Tornillo Minifix		Prego 8 x 8 Nail 8 x 8 Clavo 8 x 8		Cantoneira Bicromatizada Corner Brace Cantoneira Bicromatizada		Cantoneira Triangular Triangle Corner Brace Cantoneira Triangular
N	02 und.	O	18 und.	P	02 und.	Q	04 und.	R	20 und.	S	05 und.
	Cantoneira Metálica Metallic Corner Brace Cantoneira Metálica		Tambor Minifix Minifix Nut Tambor Minifix		Bucha Ivusa 8mm Ivusa Bushing 8mm Casquillo Ivusa 8mm		Tampa Adesiva 12mm Branca Adhesive Label 12mm White Tapa Adhesiva 12mm Blanco		Tampa Adesiva 18mm Branca Adhesive Label 18mm White Tapa Adhesiva 18mm Blanco		Sapata Retangular Rectangular Shoes Zapata Rectangular
KIT CORREDIÇA KIT SLIDING RAILS KIT RIELES	T	03 und.	U	03 und.	V	06 und.	W	02 und.	X	01 und.	
	Corredica Telescópica 400mm Telescopic Sliding Rail 400mm Rieles Telescópicos 400mm		Corredica Telescópica 400mm Telescopic Sliding Rail 400mm Rieles Telescópicos 400mm		Puxador Vitoria Vitoria Handle Tirador Vitoria		Perfil H 860mm Profile H 860mm Perfil H 860mm		Etiqueta Móveis Estrela Móveis Estrela Label Etiqueta Móveis Estrela		

FERRAGENS ESCALA REAL REAL SIZE / TAMAÑO REAL

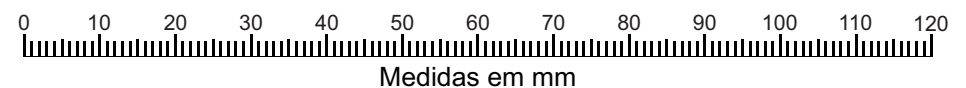
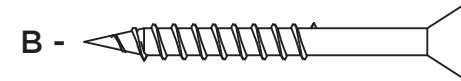
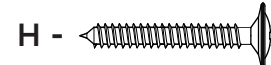
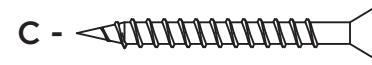

IDENTIFICAÇÃO DAS PEÇAS
IDENTIFICATION OF PARTS / IDENTIFICACIÓN DE LAS PIEZAS

CÓD.	IDENTIFICAÇÃO DAS PEÇAS	IDENTIFICATION OF PARTS	IDENTIFICACIÓN DE LAS PIEZAS	QTD
01	Tampo	Surface	Tapa	01
02	Lateral Direita	Right side	Lateral derecha	01
03	Lateral Esquerda	Left side	Lateral izquierda	01
04	Base	Panel	Montante	01
05	Frente de Gaveta Grande	Smaller Drawer Front	Frente del Cajón Mayor	02
06	Frente de Gaveta Menor	Larger Drawer Front	Frente del Cajón Menor	01
07	Apoio da Corrediça Frontal	Front Slide Support	Apoyo de la Rieles Frontal	02
08	Apoio da Corrediça Traseiro	Back Slide Support	Apoyo de la Rieles Trasero	02
09	Lateral de Gaveta Menor	Smaller Drawer Side	Lado del Cajón Menor	02
10	Contra Fundo Menor	Smaller Drawer Back	Trasera del Cajón Menor	01
11	Lateral de Gaveta Maior	Larger Drawer Side	Lado del Cajón Mayor	04
12	Contra Fundo Maior	Larger Drawer Back	Trasera del Cajón Mayor	02
13	Fundo da Gaveta	Drawer Bottom	Fondo del Cajón	03
14	Fundo Traseiro	Back Bottom	Fondo Trasero	01
15	Fundo Traseiro A	A Back Bottom	Fondo Trasero A	01
16	Fundo Traseiro B	B Back Bottom	Fondo Trasero B	01
24	Rodapé Frontal Usinado	Front Baseboard	Zócalo de la Frente	01
25	Rodapé Traseiro	Back Baseboard	Zócalo Trasero	01
26	Rodapé Lateral	Side Baseboard	Zócalo Lateral	02

ASSISTÊNCIA TÉCNICA

Ao solicitar assistência técnica, informe o número da peça, nome e cor do produto e a data de fabricação do lote que se encontra carimbado na peça nº16.

TECHNICAL ASSISTANCE

When request the technical assistance, inform the number of the piece name and color of the product and also the batch manufacturing date, that is stamped on the piece nº16.

ASISTENCIA TÉCNICA

Al solicitar la asistencia técnica, informe el número de la pieza, el nombre y el color del producto y también la fecha de fabricación del lote, que se estampa en la pieza nº16.

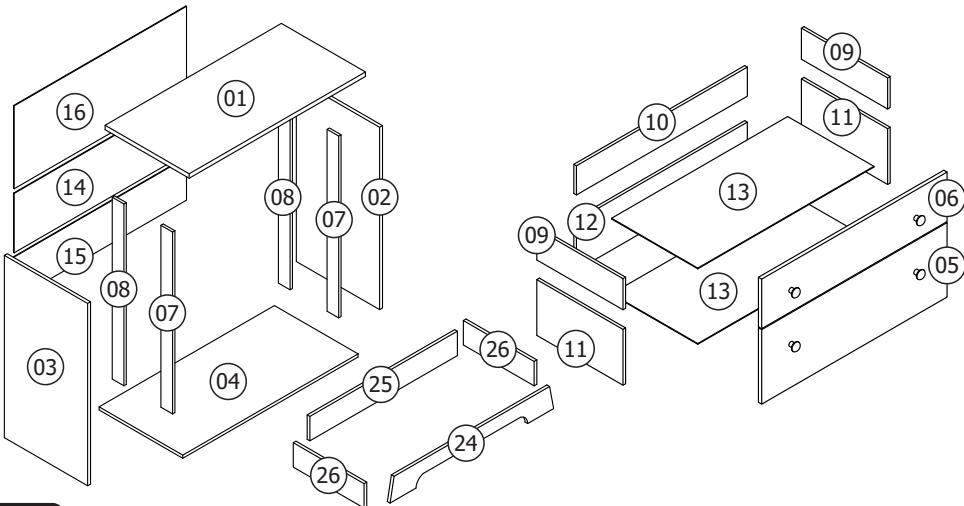

04





MONTAGEM DO PRODUTO
PRODUCT ASSEMBLY / MONTAJE DEL PRODUCTO

PASSO / STEP / PASO 1

Prepare as peças N°01, 02, 03, 04, 05, 06, 09, 11, 24, 25 e 26 'J', 'A' e 'O'. Fixe 'S' nas peças N°24 e 25 utilizando 'K'.

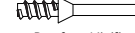
Prepare the pieces N°01, 02, 03, 04, 05, 06, 09, 11, 24, 25 e 26 using 'J', 'A' and 'O'. Fix 'S' on the pieces N°24 and 25 using 'K'.

Preparare las piezas N°01, 02, 03, 04, 05, 06, 09, 11, 24, 25 y 26 utilizando 'J', 'A' y 'O'. Fije 'S' en las piezas N°24 y 25 utilizando 'K'.

A	20 und.	J	18 und.	O	18 und.
					
Cavilha 6 x 30 Dowel 6 x 30 Clavija 6 x 30		Parafuso Minifix Minifix Screw Tornillo Minifix		Tambor Minifix Minifix Nut Tambor Minifix	
K	10 und.	S	05 und.		
					
Prego 8 x 8 Nail 8 x 8 Clavo 8 x 8		Sapata Retangular Rectangular Shoes Zapata Rectangular			

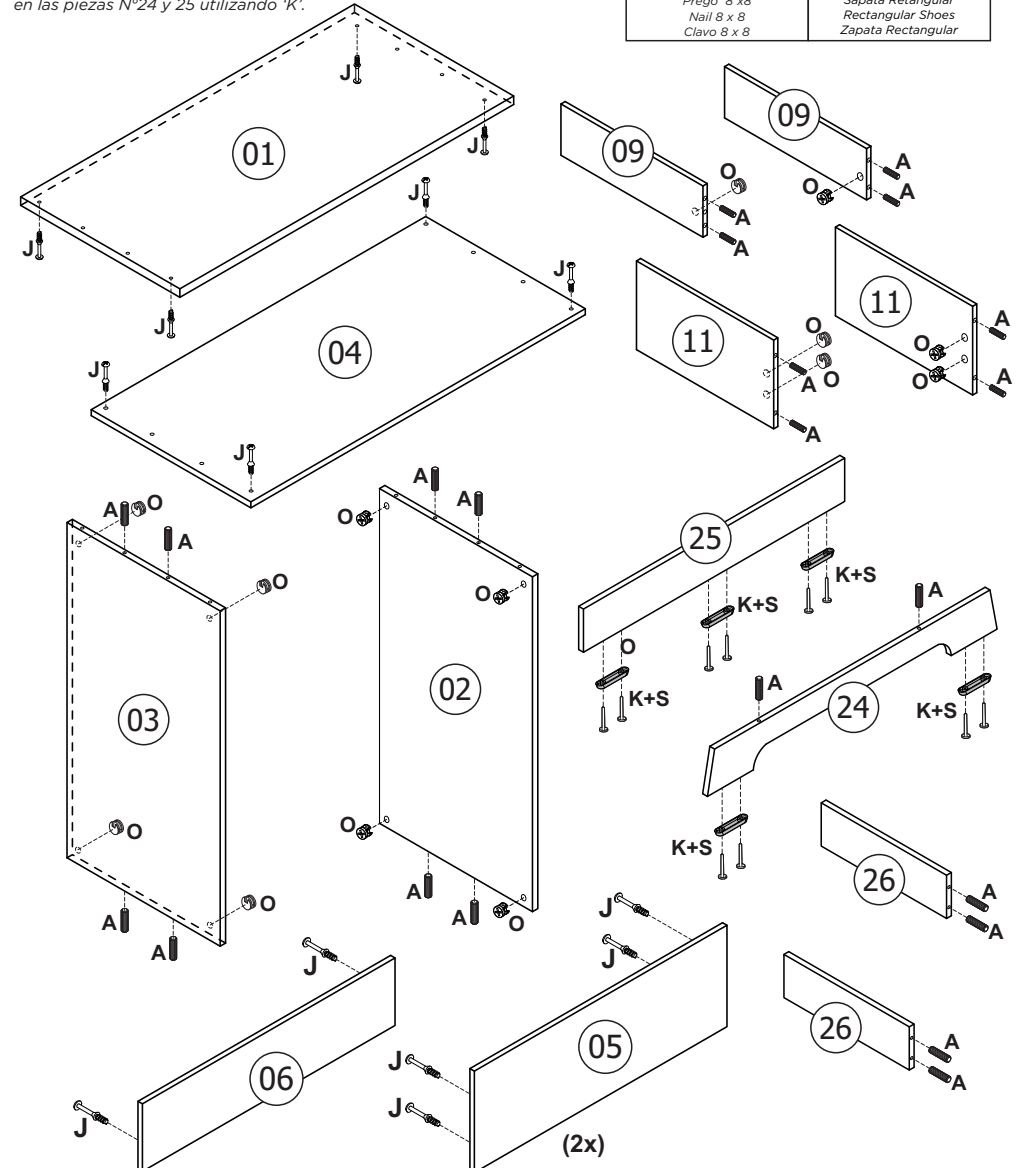

05