

Mesa Dora Quadrada 900mm | Mesa Plaza Dora 900mm | Dora Aquare Table 1600mm

S211-127 - Nature/OFF White

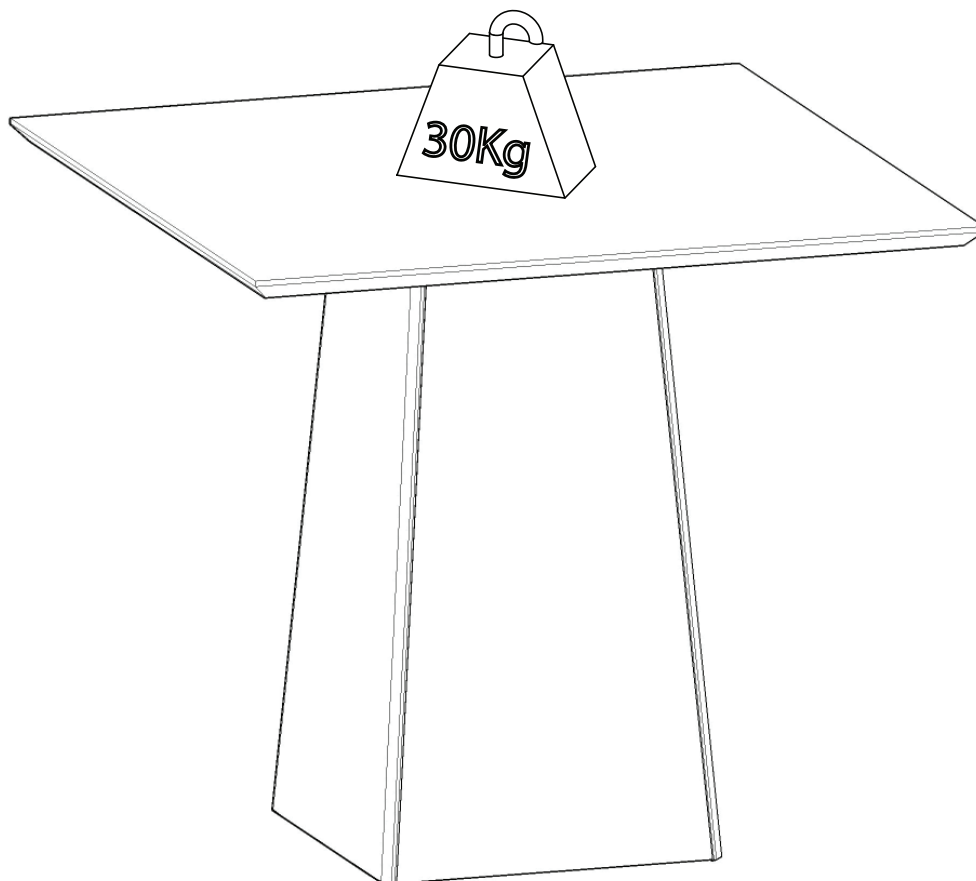

Pesos máximos recomendados com carga distribuída
Peso máximo recomendado con la carga distribuida
Recommended maximum weights with evenly distributed.

Requisitos para montagem Requisitor para la montaje Assembly Requirements

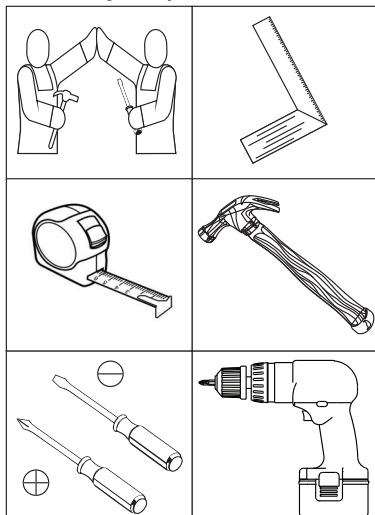

Imagens meramente ilustrativas
Imágenes meramente ilustrativas
Images for illustration only

AVISO

Para limpeza de seu móvel, use uma flanela seca ou umedecida, e não utilize produtos químicos que possam danificar seu produto.

SISTEMA DE MONTAGEM

O sistema de montagem dos produtos, funciona de acordo com a ordem crescente dos números indicados no desenho. Ex: 01, 02, 03, 04... até a conclusão da montagem.

ADVERTENCIA

Para limpieza de su móvel, use una flanela seca o húmeda, y no utilice productos químicos que puedan dañar su producto.

SISTEMA DE MONTAJE

El sistema de montaje de los productos funciona de acuerdo con el orden creciente de los números indicados en el dibujo. Ej.: 01, 02, 03, 04... hasta la conclusión del montaje.

NOTICE

To clean your furniture, use a dry or wet cloth, and do not use chemicals that may damage your product.

ASSEMBLY SYSTEM

The products' assembly system works according to the increasing order of the indicated numbers. For example: 01, 02, 03, 04 ... to the end of the assembly.

1

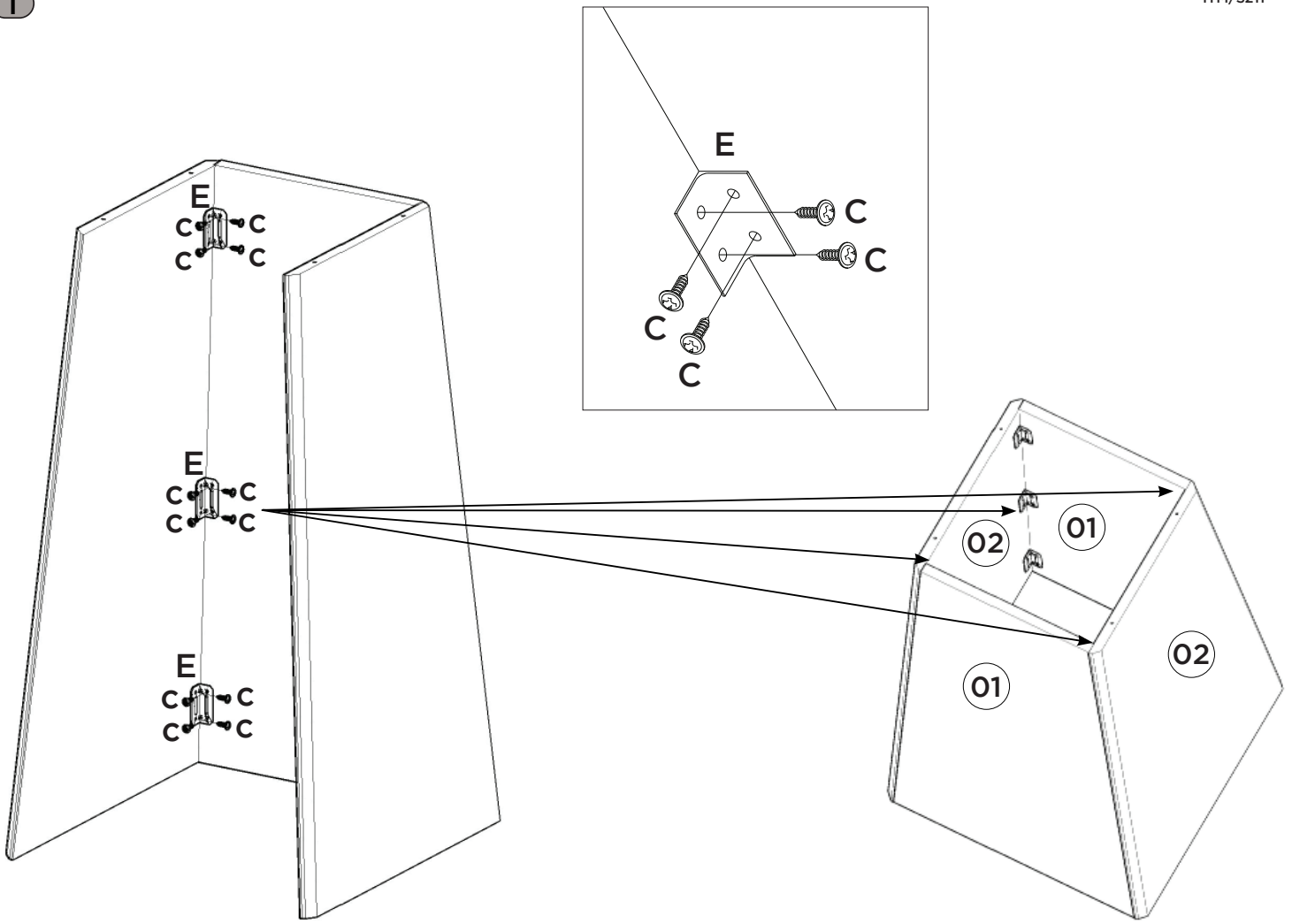

2

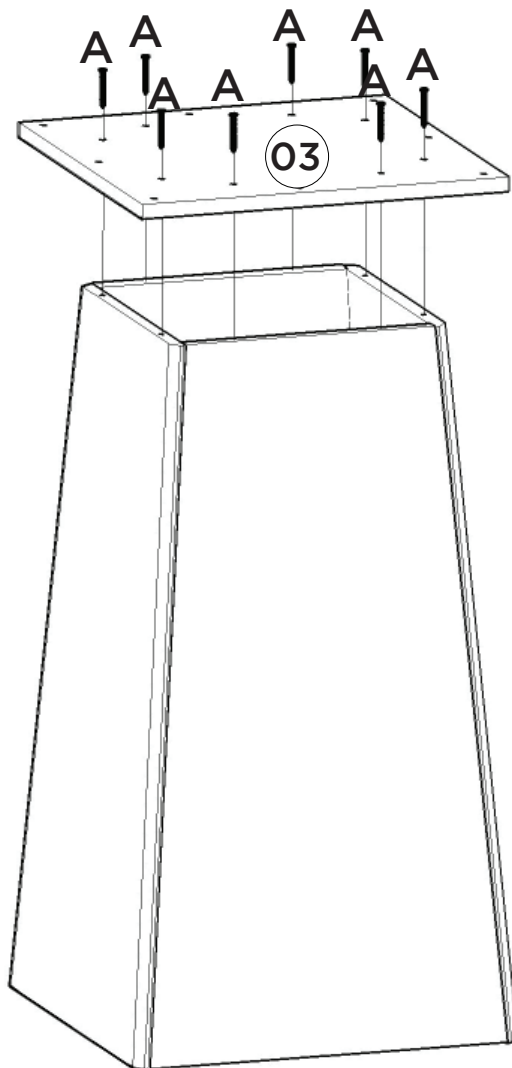

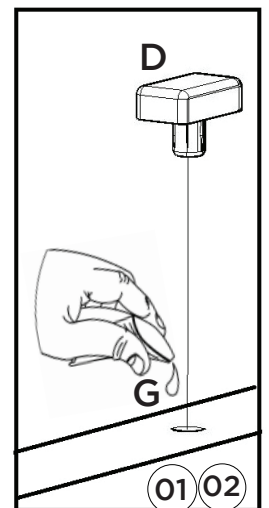
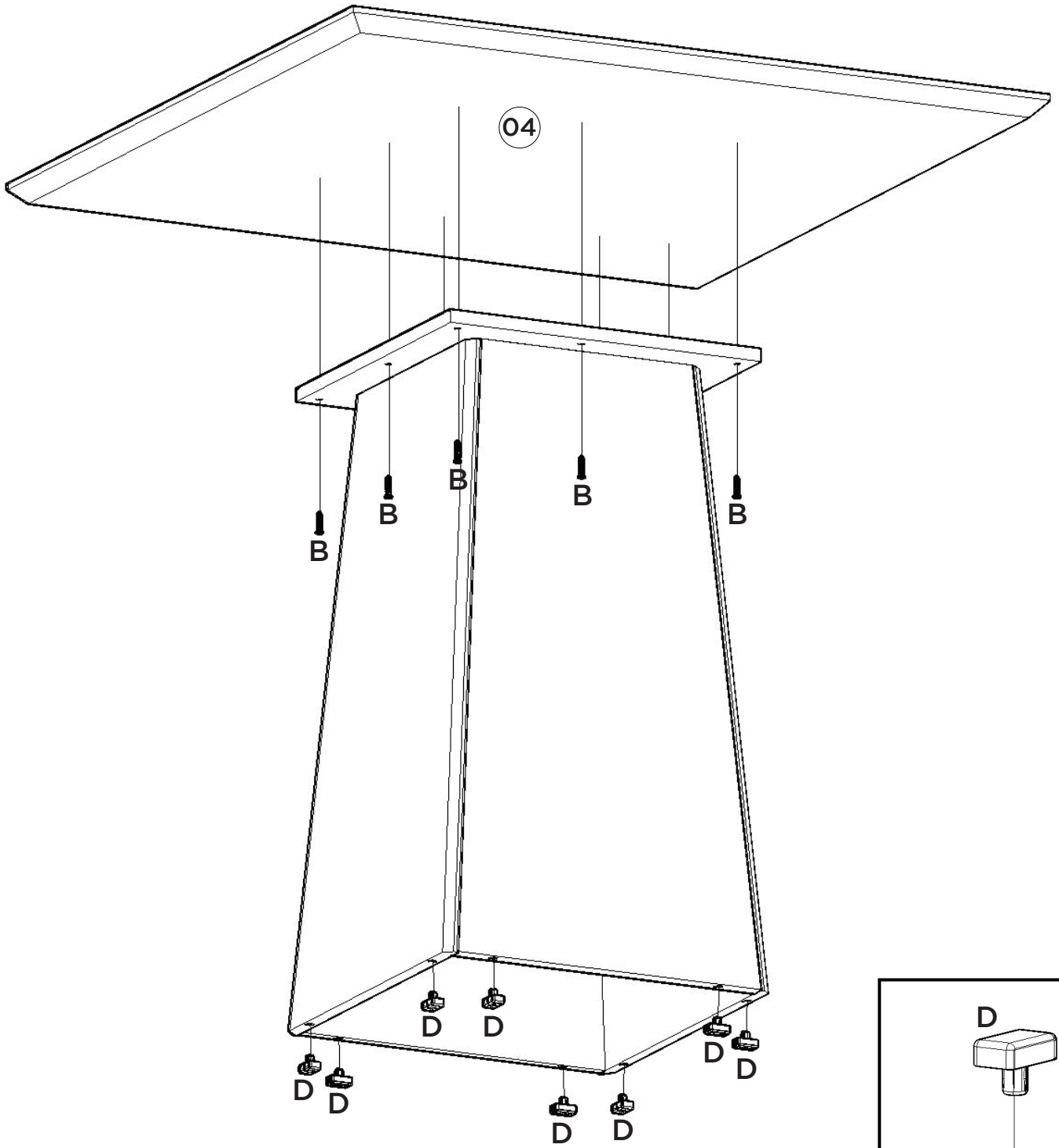

Item	Caixa Caja Box	Qtd Ctd Qty	Descrição Descripción Description	Medidas (mm) Dimensions (mm) Size (measurements) (mm)
01	1/2	02	Painel Menor Panel más pequeño Smaller panel	757x390x15
02	1/2	02	Painel Panel Panel	757x420x15
03	1/2	01	Tampo Estrutural Superfície estrutural Structural Top	400x400x15
04	2/2	01	Tampo Tapa Top	898x898x25

Ferragens | Herrajes | Hardware

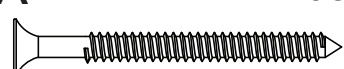
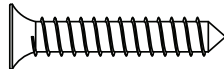
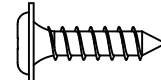
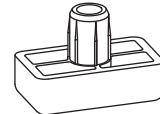
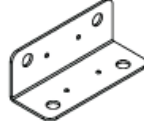
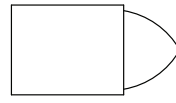
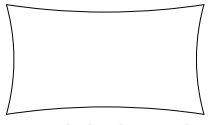
<p>A 08x</p>  <p>Parafuso 3,5x40mm CHT. Tornillo 3,5x40mm CHT. Screw 3,5x40mm CHT.</p>	<p>B 08x</p>  <p>Parafuso 4,0x25mm CHT. Tornillo 4,0x25mm CHT. Screw 4,0x25mm CHT.</p>	<p>C 48x</p>  <p>Parafuso 3,5x14mm FLA. Tornillo 3,5x14mm FLA. Screw 3,5x14mm FLA.</p>	<p>D 08x</p>  <p>Sapata Deslizante 15x26x8mm Zapato deslizante 15x26x8mm Sliding Shoe 15x26x8mm</p>
<p>E 12x</p>  <p>Cantoneira 17,5x17,5x44 Cantonera 17,5x17,5x44 Angle 17,5x17,5x44</p>	<p>F 02x</p>  <p>Giz de correção Tiza de corrección Chalk of correction</p>	<p>G 01x</p>  <p>Sachê de cola Bolsa de pegamento Glue bag</p>	

CADEIRA ISA

S11-500 Nature Marrom

S11-501 Nature Bege

S11-502 Nature Linho

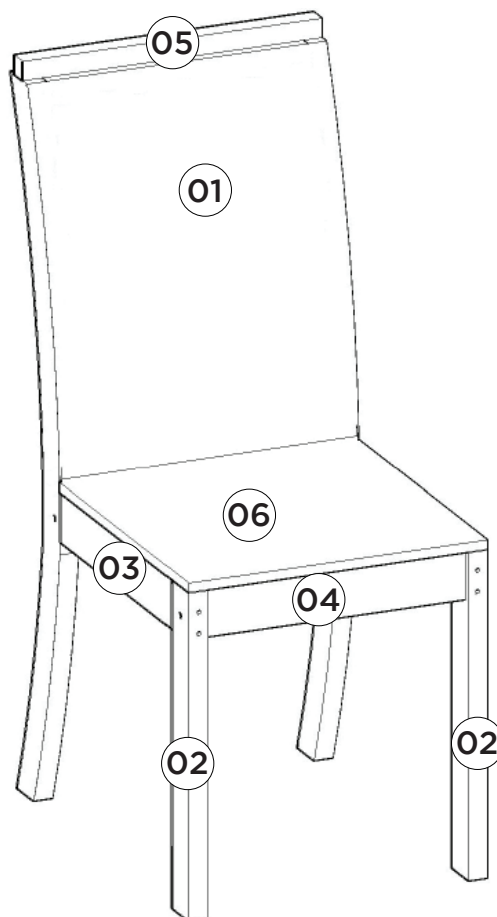
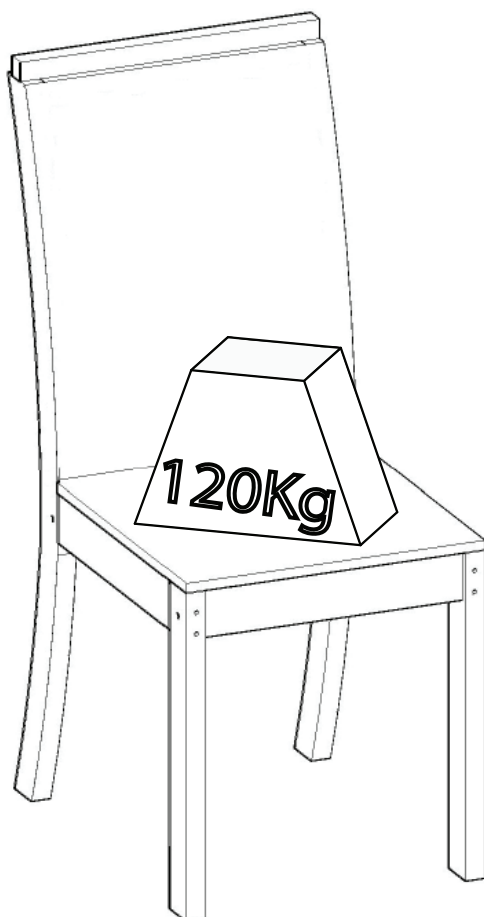

Requisitos para montagem Requisitor para la montaje Assembly Requirements

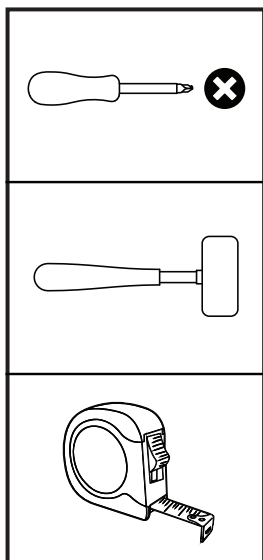

Imagens meramente ilustrativas,
não acompanha o produto.
Imágenes ilustrativas, no incluidas
con el producto.
Illustrative images, not included
with the product.

AVISO

Para limpeza de seu móvel, use uma flanela seca ou umedecida, e não utilize produtos químicos que possam danificar seu produto.

SISTEMA DE MONTAGEM

O sistema de montagem dos produtos, funciona de acordo com a ordem crescente dos números indicados no desenho. Ex: 01, 02, 03, 04... até a conclusão da montagem.

ADVERTENCIA

Para limpieza de su móvil, use una flanela seca o húmeda, y no utilice productos químicos que puedan dañar su producto.

SISTEMA DE MONTAJE

El sistema de montaje de los productos funciona de acuerdo con el orden creciente de los números indicados en el dibujo. Ej.: 01, 02, 03, 04... hasta la conclusión del montaje.

NOTICE

To clean your furniture, use a dry or wet cloth, and do not use chemicals that may damage your product.

ASSEMBLY SYSTEM



The products' assembly system works according to the increasing order of the indicated numbers. For example: 01, 02, 03, 04 ... to the end of the assembly.

1 Pré Montagem Preasamblea | Pre-assembly

Peças Necessárias | Partes requeridas | Required Parts:

1	Encosto Respaldo Backrest	x4
2	Pé Frontal Pie delantero Front foot	x8

Ferragens | Herrajes | Hardware:

F		x16
K		

Ferramentas | Instrumentos | Tools:

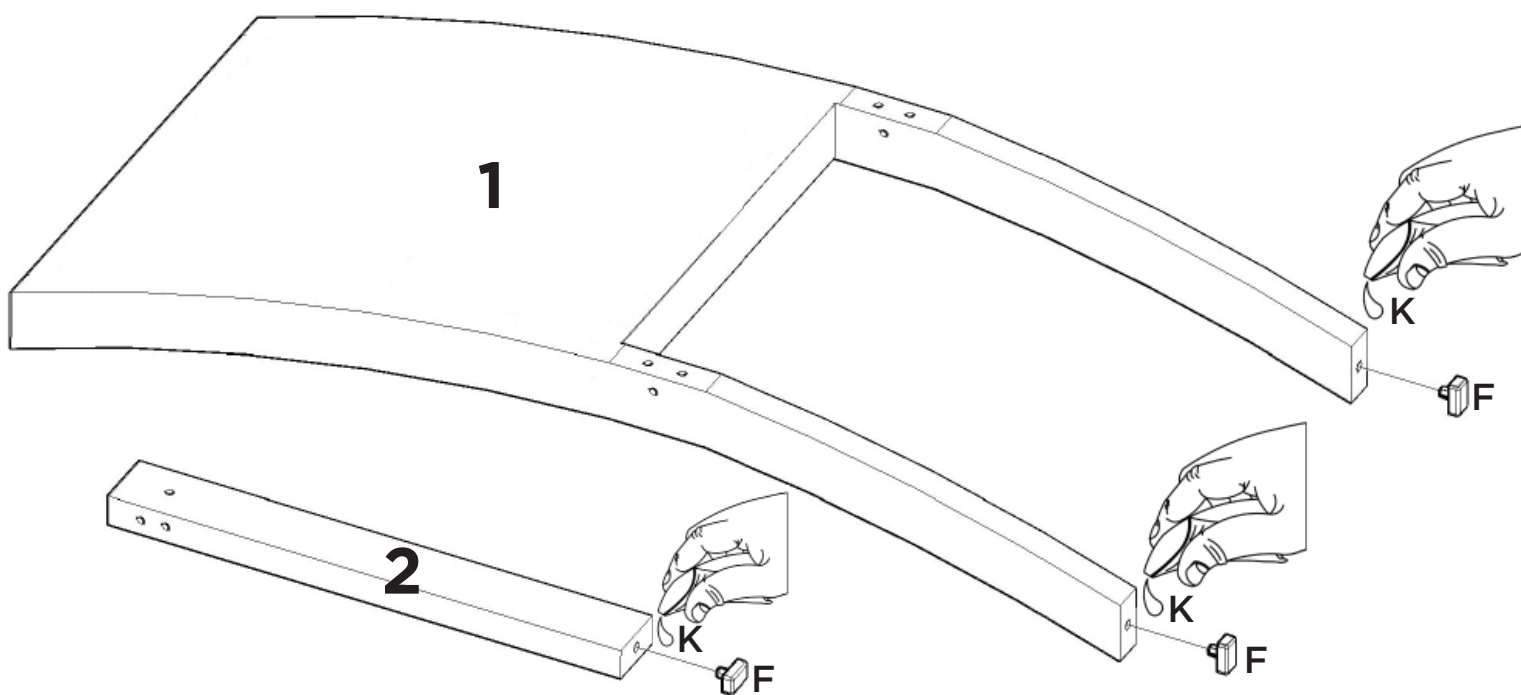
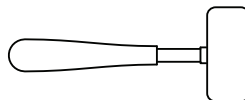



2 Pré Montagem Preasamblea | Pre-assembly

Peças Necessárias | Partes requeridas | Required Parts:

3	Travessa Lateral Plato lateral Side Platter	x8
4	Travessa Frontal Plato delantero Front Platter	x8
5	Moldura Superior Marco superior Top Frame	x4

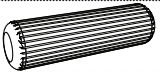
Ferragens | Herrajes | Hardware:

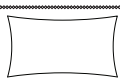
D		x8
E		x48
K		

Ferramentas | Instrumentos | Tools:

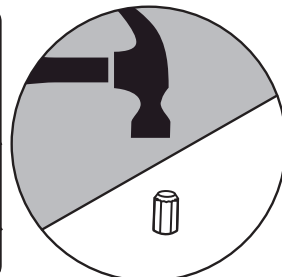
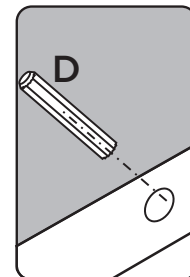
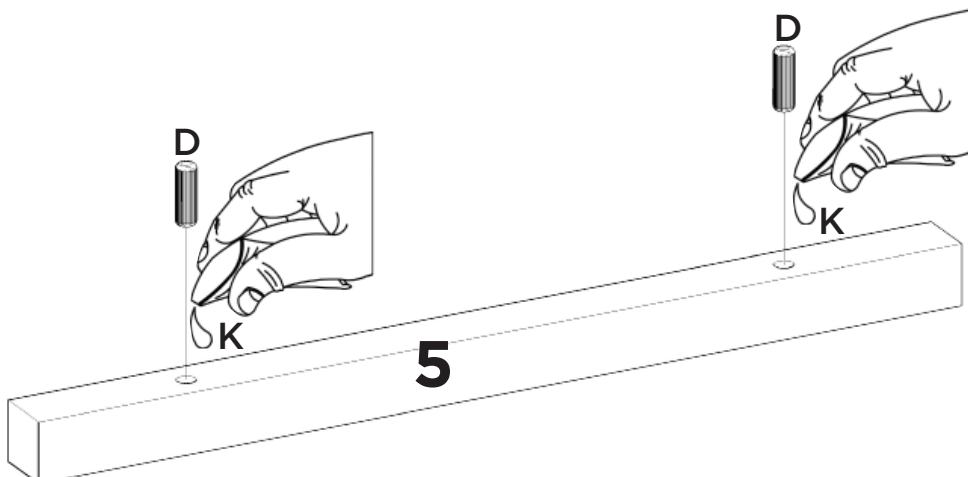
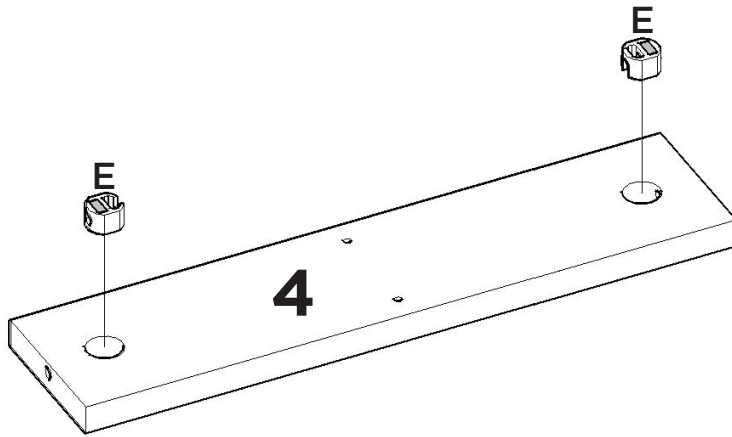
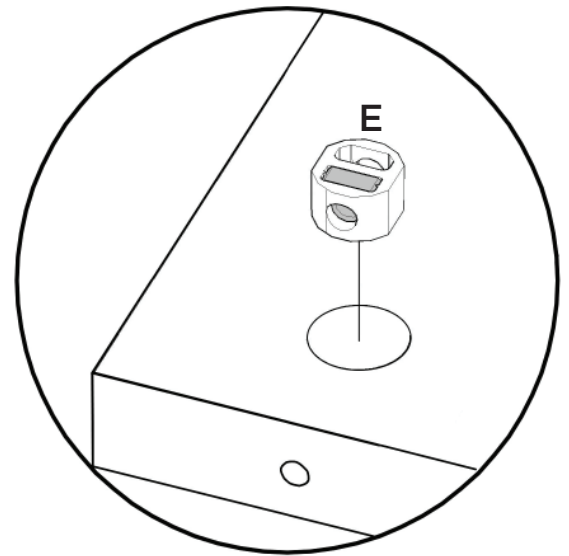
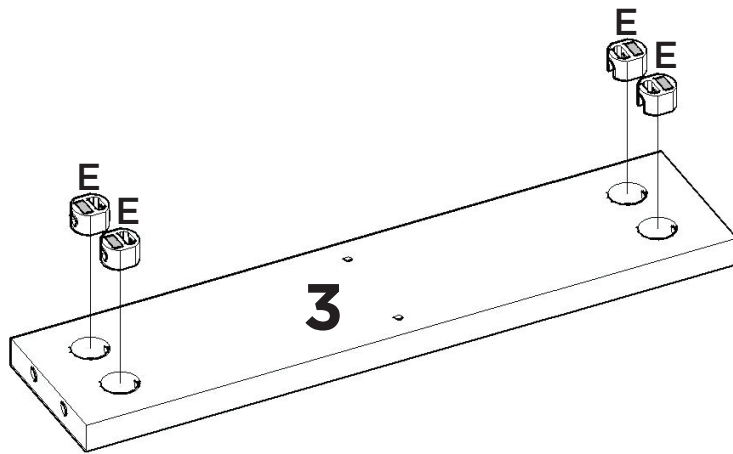
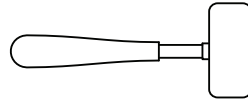



3

Peças Necessárias | Partes requeridas | Required Parts:

1	Encosto Respaldo Backrest	x4
2	Pé Frontal Pie delantero Front foot	x4
3	Travessa Lateral Plato lateral Side Platter	x4

Ferragens | Herrajes | Hardware:

A		x16
H		

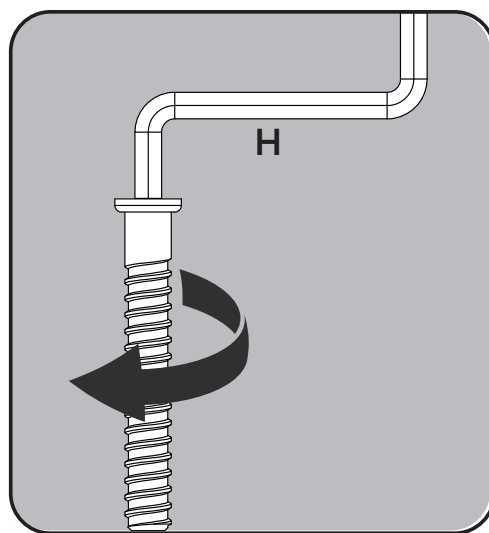
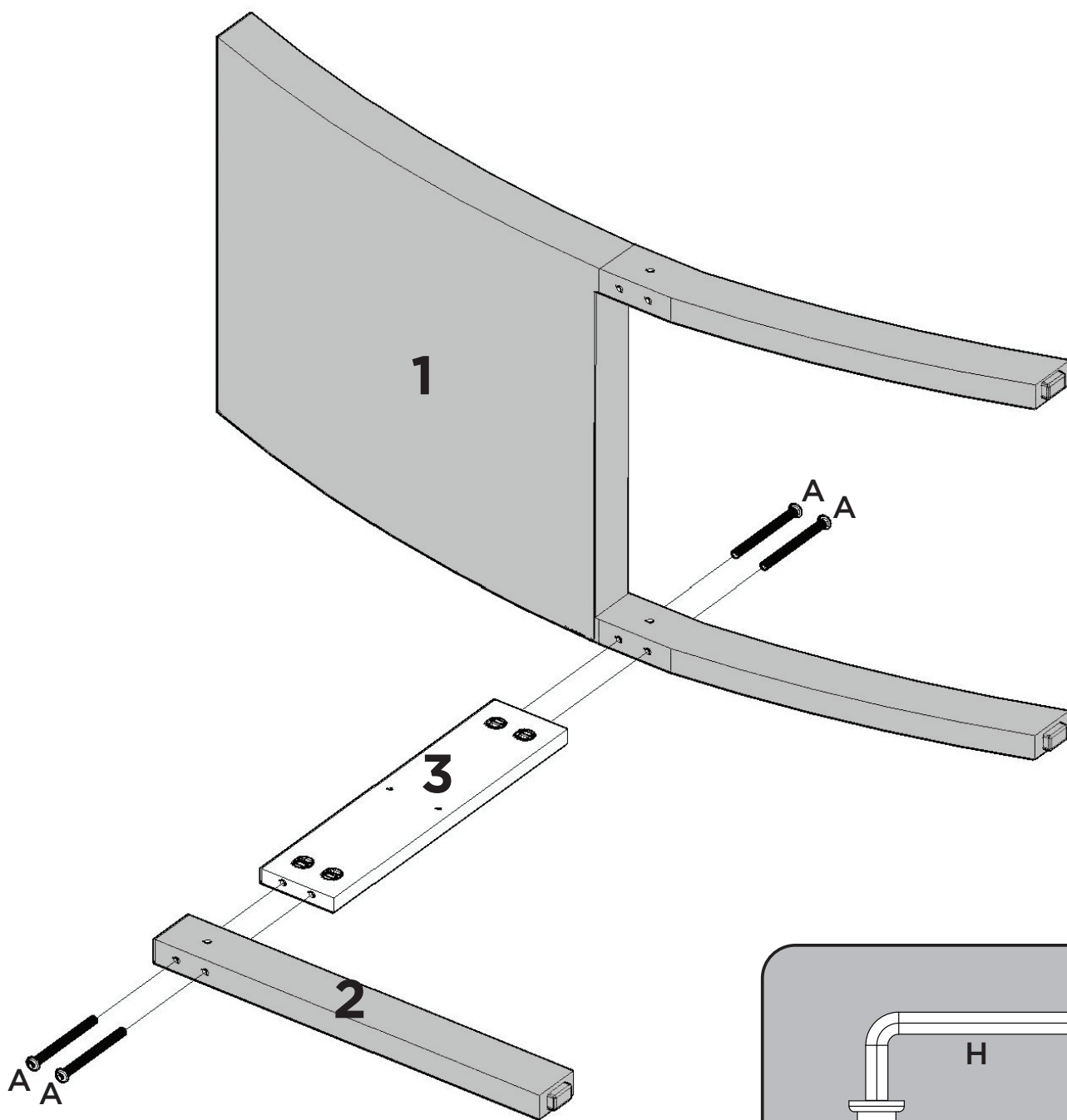



4

Peças Necessárias | Partes requeridas | Required Parts:

4	Travessa Frontal Plato delantero Front Platter	x4
---	--	----

Ferragens | Herrajes | Hardware:

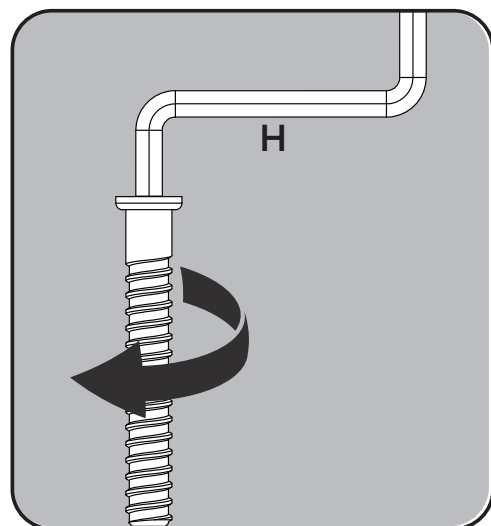
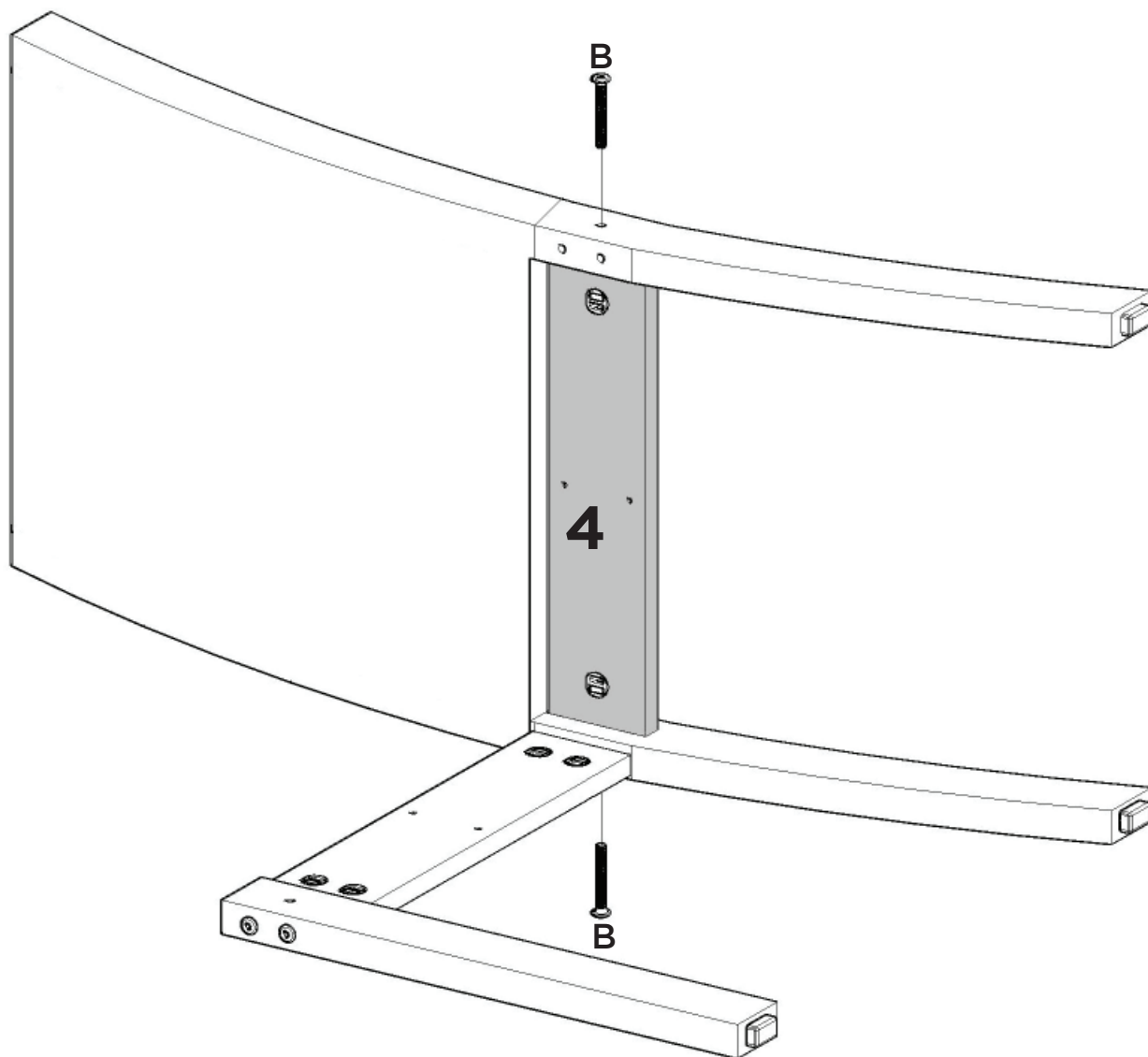

B		x8
H		



Peças Necessárias | Partes requeridas | Required Parts:

2	Pé Frontal Pie delantero Front foot	x4
3	Travessa Lateral Plato lateral Side Platter	x4

Ferragens | Herrajes | Hardware:

A		x16
H		

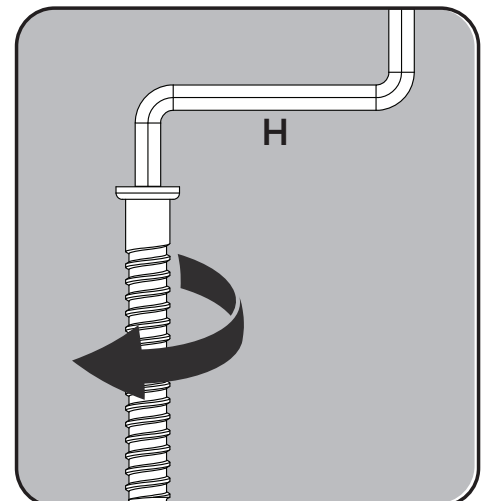
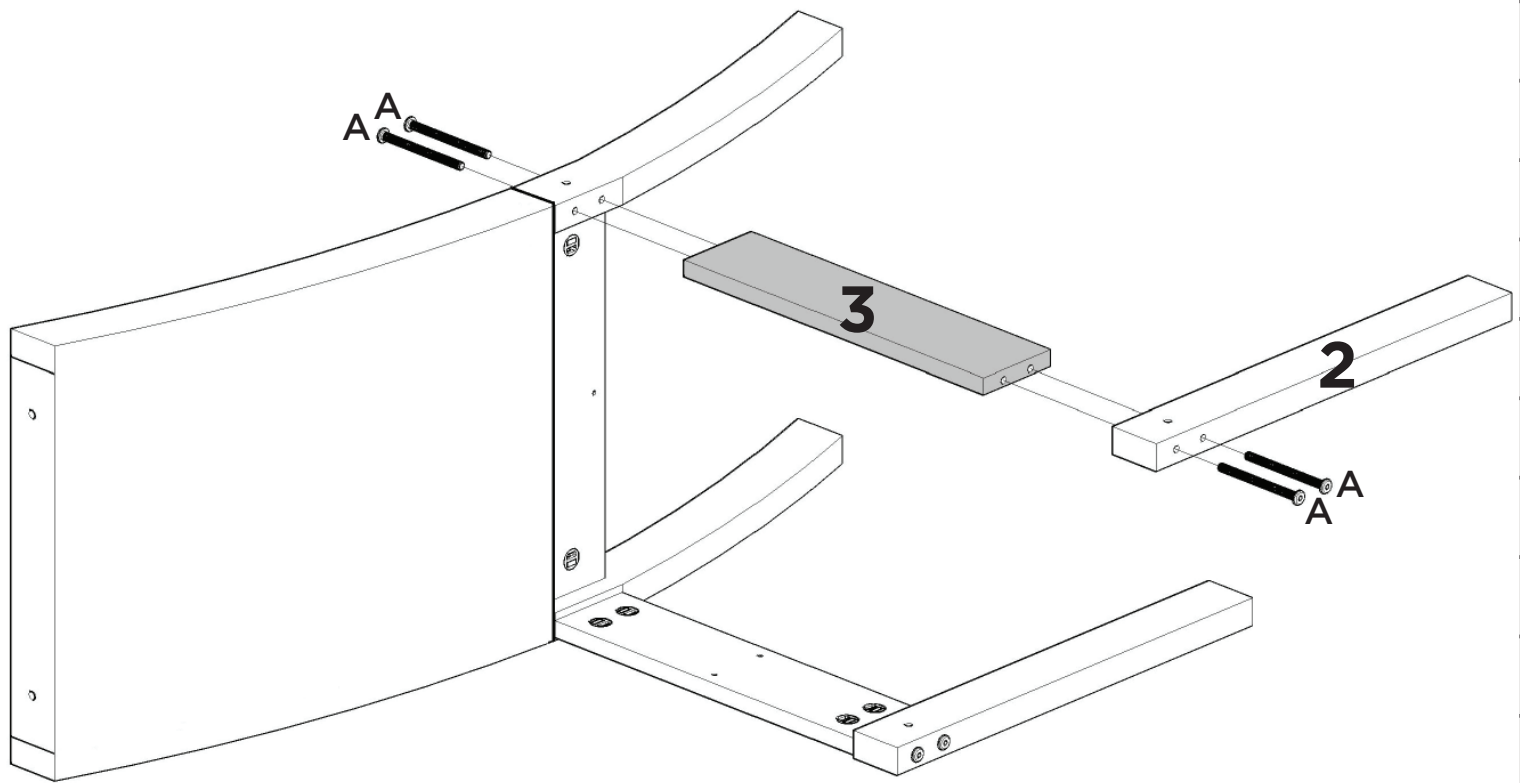



6

Peças Necessárias | Partes requeridas | Required Parts:

4	Travessa Frontal Plato delantero Front Platter	x4
---	--	----

Ferragens | Herrajes | Hardware:

B		x8
H		

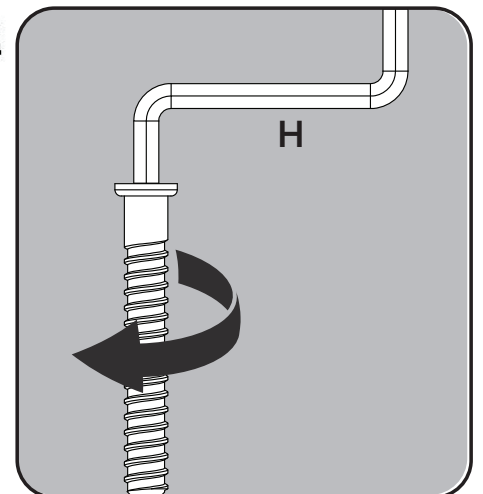
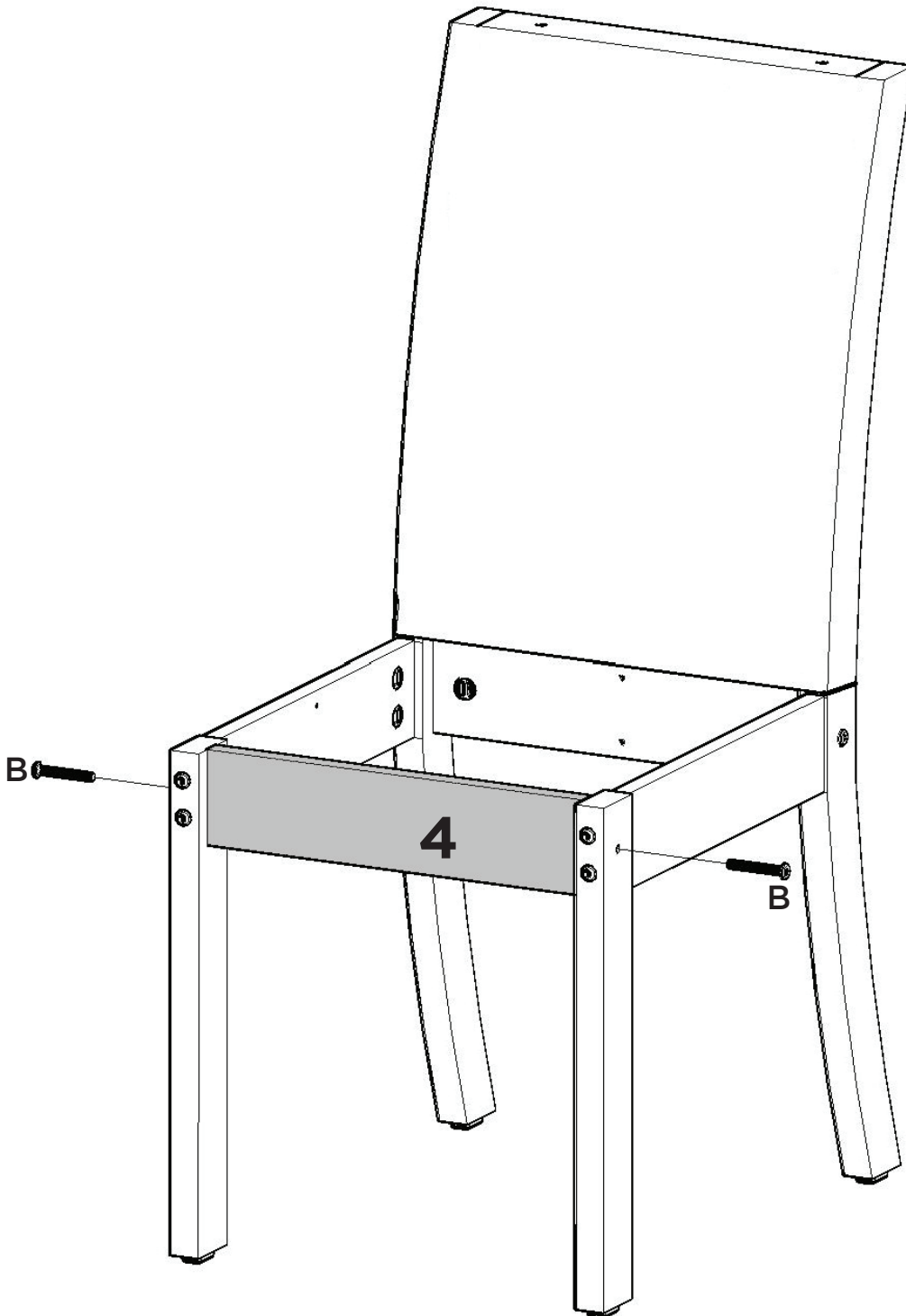



7

Peças Necessárias | Partes requeridas | Required Parts:

5	Moldura Superior Marco superior Top Frame	x4
---	---	----

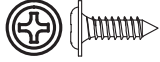
Ferragens | Herrajes | Hardware:

C		x16
G		x16
K		

Ferramentas | Instrumentos | Tools:

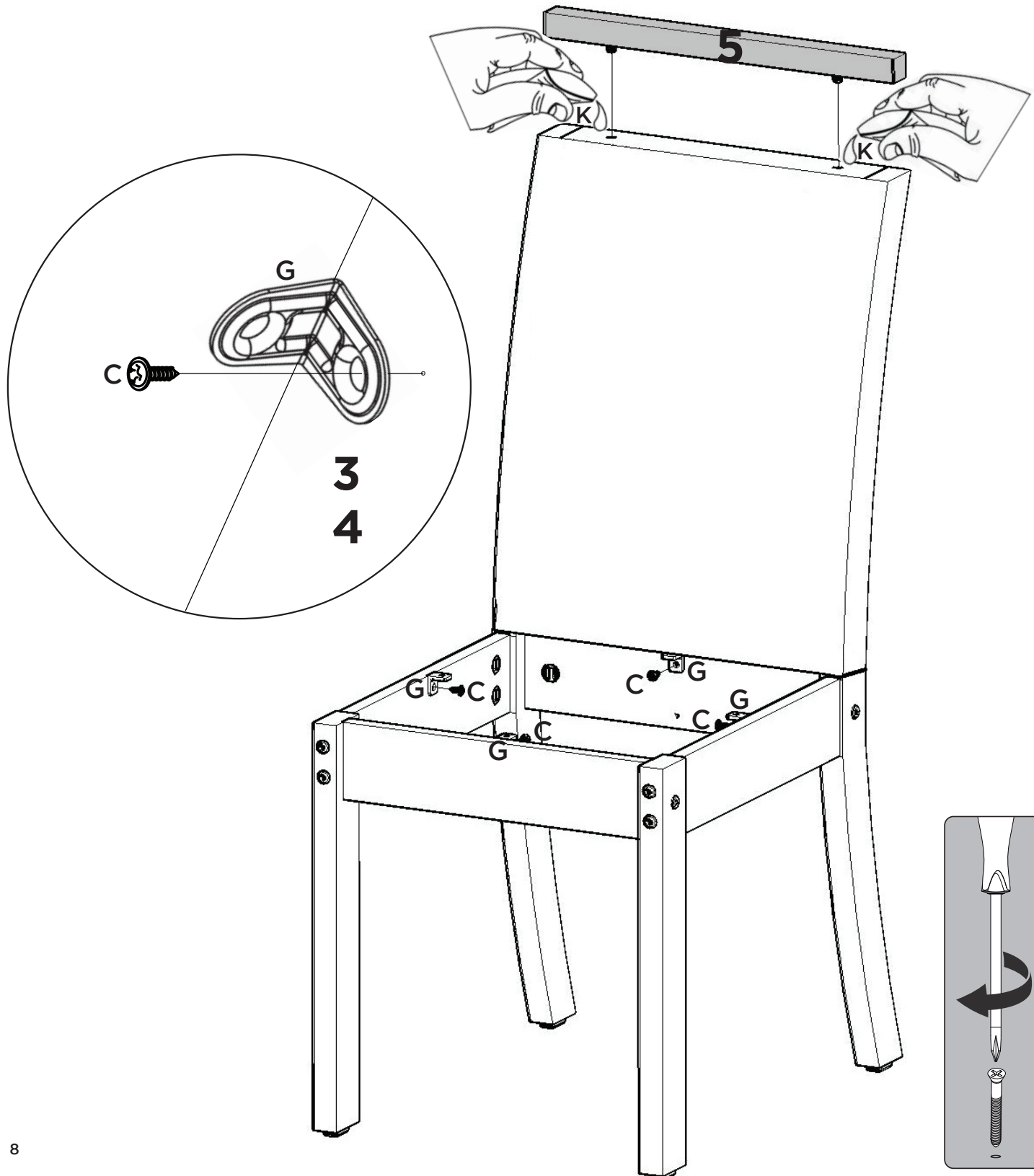
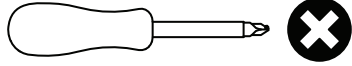

Peças Necessárias | Partes requeridas | Required Parts:

6	Assento Asiento Seat	x4
---	--------------------------	----

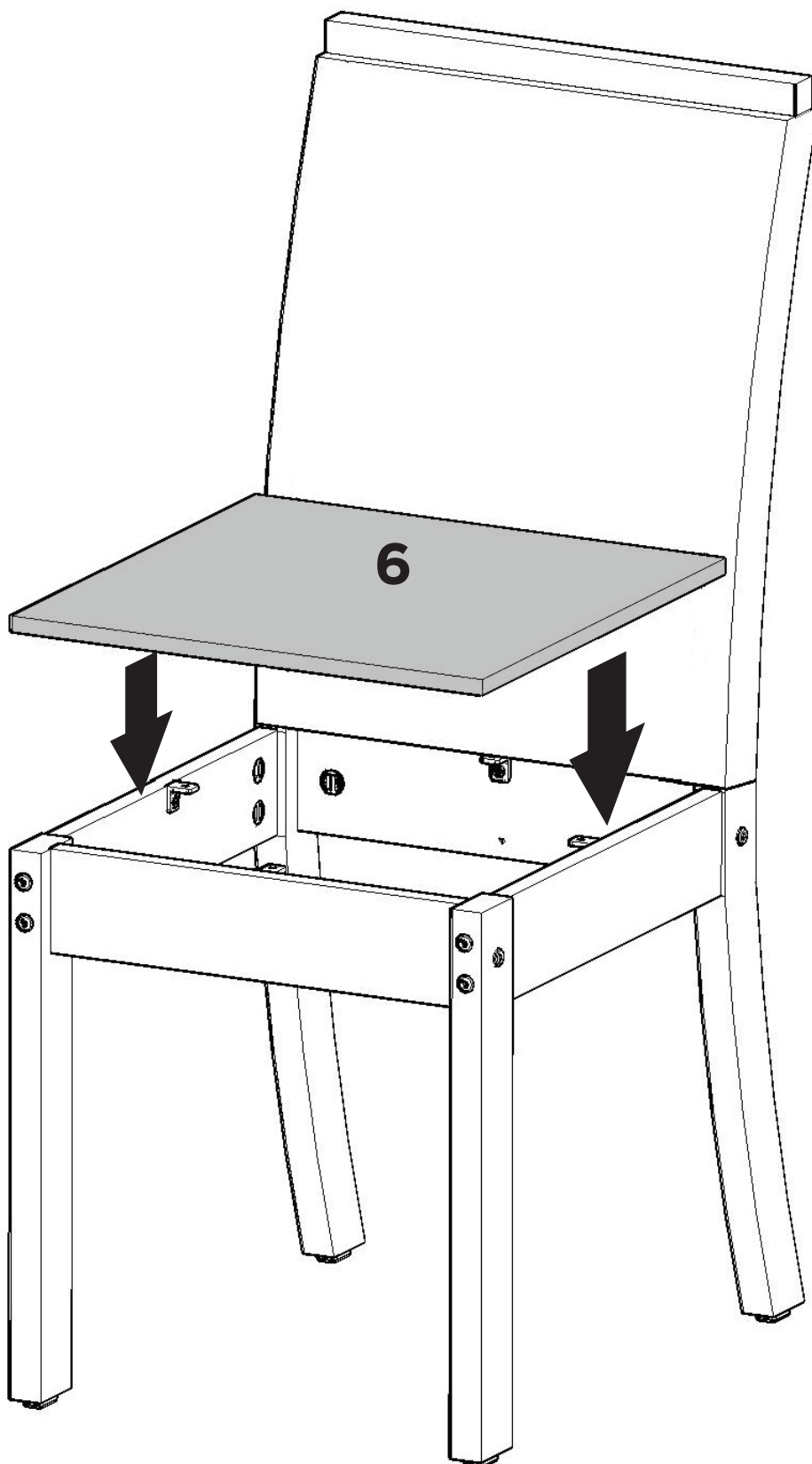

9

Ferragens | Herrajes | Hardware:

C		x16
---	---	-----

Ferramentas | Instrumentos | Tools:

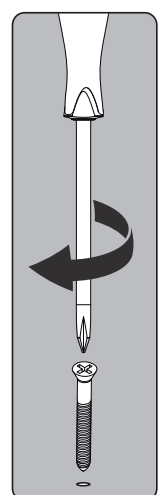
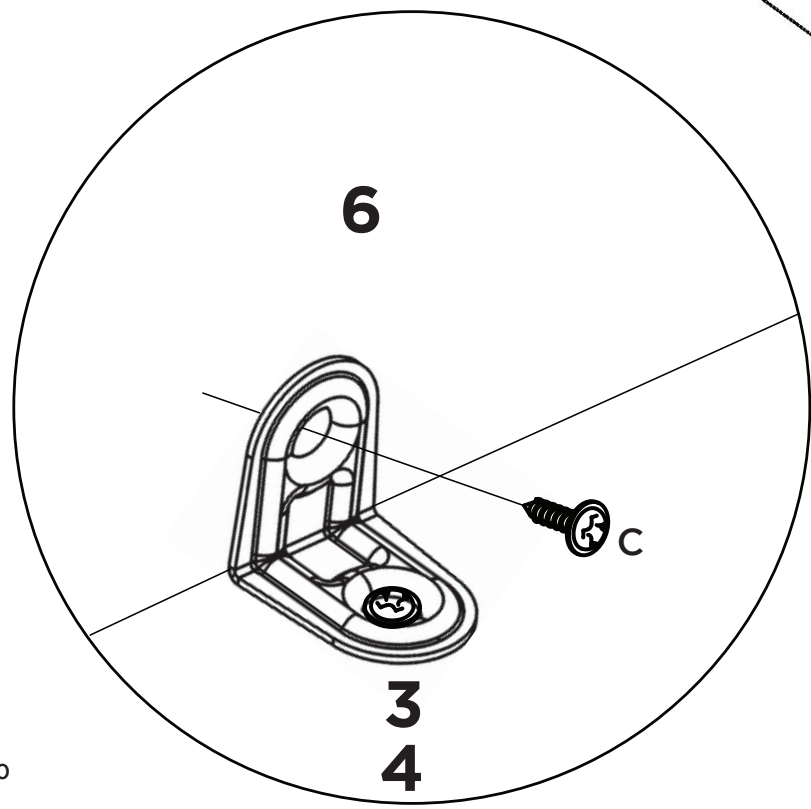
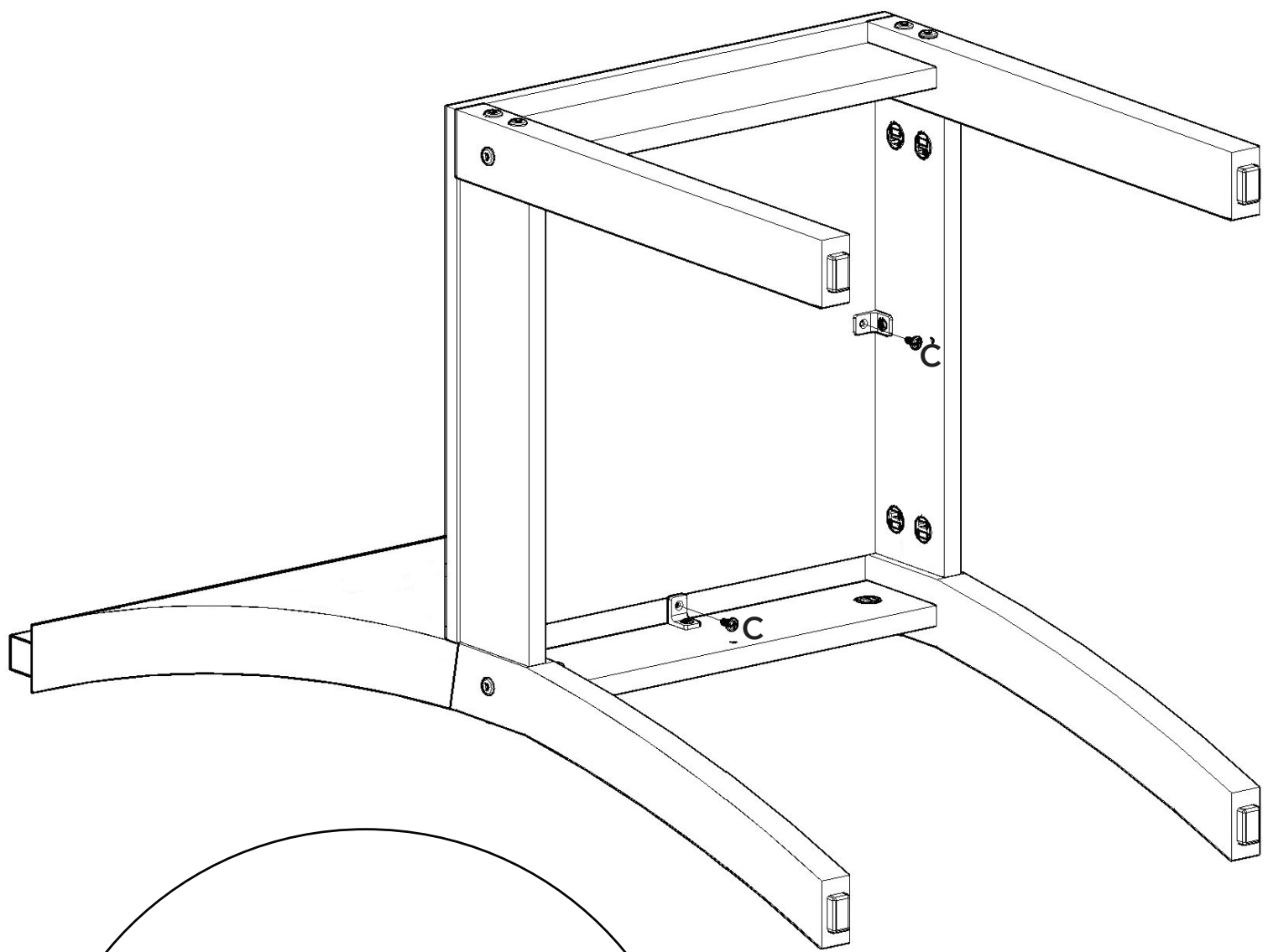
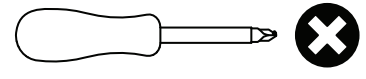

Ferragens | Herrajes | Hardware:

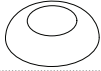
I		x48
---	---	-----

Pesos máximos recomendados com carga distribuída
Peso máximo recomendado con la carga distribuida
Recommended maximum weights with evenly distributed.

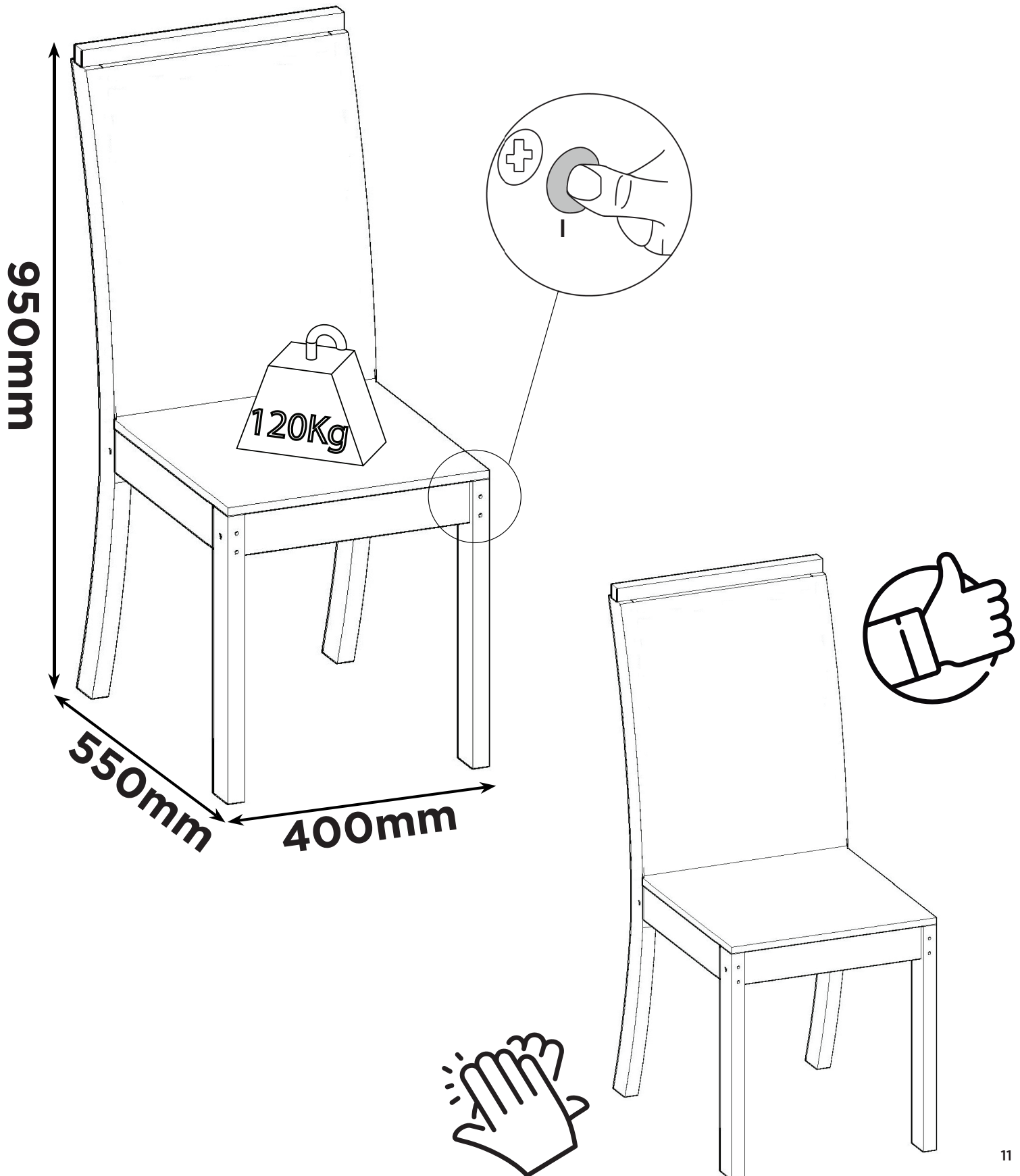





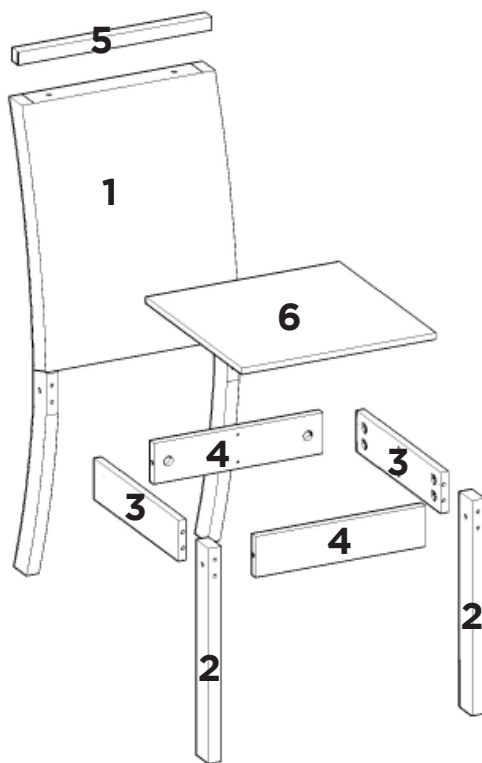

Item	Caixa Caja Box	Qtd Ctd Qty	Descrição Descripción Description	Medidas (mm) Dimensions (mm) Size (measurements) (mm)
1	1/1	04	Encosto Estofado Respaldo tapizado Upholstered backrest	925 x 400 x 155
2	1/1	08	Pé Frontal Pie delantero Front foot	425 x 50 x 25
3	1/1	08	Travessa Lateral Plato lateral Side Platter	345 x 80 x 15
4	1/1	08	Travessa Frontal Plato delantero Front Platter	345 x 80 x 15
5	1/1	04	Moldura Superior Marco superior Top Frame	395 x 25 x 25
6	1/1	04	Assento Estofado Asiento tapizado Upholstered seat	400 x 400 x 40

O volume contém peças para montagem de 4 Cadeiras.
 El volumen contiene piezas para montar 4 sillas.
 The volume contains parts for mounting 4 Chairs.

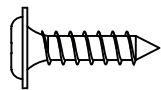
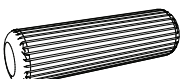
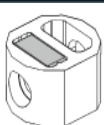

Ferragens | Herrajes | Hardware

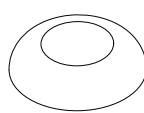
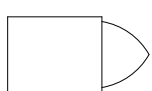
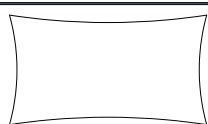
A	32x	B	16x	C	32x	D	08x
							
Parafuso Cab PL 17 Allen 4.14x3.12 (90mm) Tornillo PL 17 Allen 4.14x3.12 (90mm) Screw PL 17 Allen 4.14x3.12 (90mm)		Parafuso Cab PL 17 Allen 4.14x3.12 (60mm) Tornillo PL 17 Allen 4.14x3.12 (60mm) Screw PL 17 Allen 4.14x3.12 (60mm)		Parafuso 3,5x14mm FLA. Tornillo 3,5x14mm FLA. Screw 3,5x14mm FLA.		Cavilha Madeira 10x35mm Taco de madeira de 10x35 mm 10x35mm wooden dowel	
E	48x	F	16x	G	16x	H	01x
							
Porca meia lua plástica rosca 1/4 1/4 tuerca de media luna de plástico 1/4 plastic half moon nut		Sapata Deslizante 15x26x8mm Zapato deslizante 15x26x8mm Sliding Shoe 15x26x8mm		Cantoneira Metal 18x18mm 18x18mm esquina de metal Soporte Metal Corner Bracket 18x18mm		Chave Allen llave Allen Allen key	
I	48x	J	01x	K	02x		
							
Tapa Parafuso Soft 17mm Tapón de rosca suave de 17 mm Soft Screw Cap 17mm		Giz de correção Tiza de corrección Chalk of correction		Sachê de cola Bolsa de pegamento Glue bag			