

HENN

Ind. e Com. de Móveis Henn
Mondai - SC - Brasil

+55 49 3674.3500

@moveishenn
www.henn.com.br

INSTRUÇÕES DE MONTAGEM

INSTRUCCIONES DE MONTAJE
ASSEMBLY INSTRUCTIONS

CADEIRA ISA

S12-500 Nature Marrom

S12-501 Nature Bege

S12-502 Nature Linho

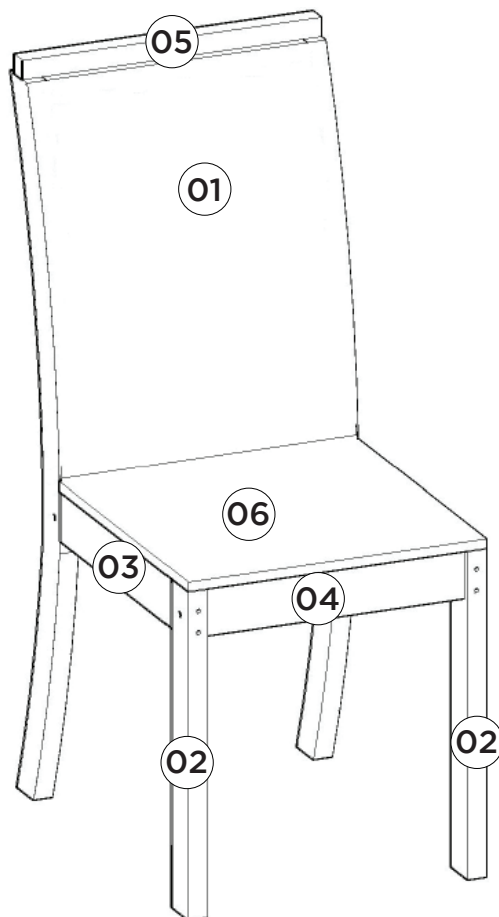
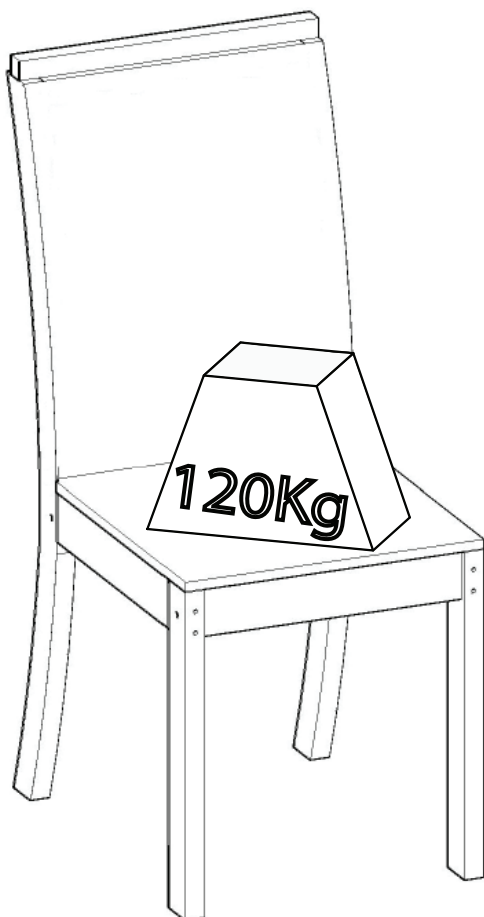

Requisitos para montagem
Requisitor para la montaje
Assembly Requirements

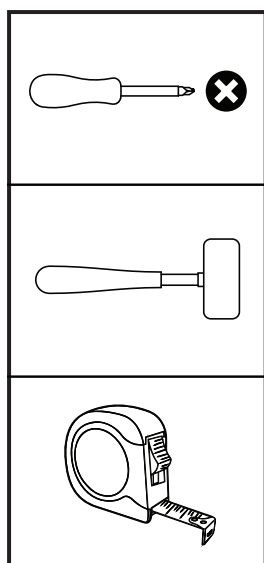

Imagens meramente ilustrativas,
não acompanha o produto.
Imágenes ilustrativas, no incluidas
con el producto.
Illustrative images, not included
with the product.

AVISO

Para limpeza de seu móvel, use uma flanela seca ou umedecida, e não utilize produtos químicos que possam danificar seu produto.

SISTEMA DE MONTAGEM

O sistema de montagem dos produtos, funciona de acordo com a ordem crescente dos números indicados no desenho. Ex: 01, 02, 03, 04... até a conclusão da montagem.

ADVERTENCIA

Para limpieza de su móvil, use una flanela seca o húmeda, y no utilice productos químicos que puedan dañar su producto.

SISTEMA DE MONTAJE

El sistema de montaje de los productos funciona de acuerdo con el orden creciente de los números indicados en el dibujo. Ej.: 01, 02, 03, 04... hasta la conclusión del montaje.

NOTICE

To clean your furniture, use a dry or wet cloth, and do not use chemicals that may damage your product.

ASSEMBLY SYSTEM



The products' assembly system works according to the increasing order of the indicated numbers. For example: 01, 02, 03, 04 ... to the end of the assembly.

1 Pré Montagem Preasamblea | Pre-assembly

Peças Necessárias | Partes requeridas | Required Parts:

1	Encosto Respaldo Backrest	x6
2	Pé Frontal Pie delantero Front foot	x12

Ferragens | Herrajes | Hardware:

F		x24
K		

Ferramentas | Instrumentos | Tools:

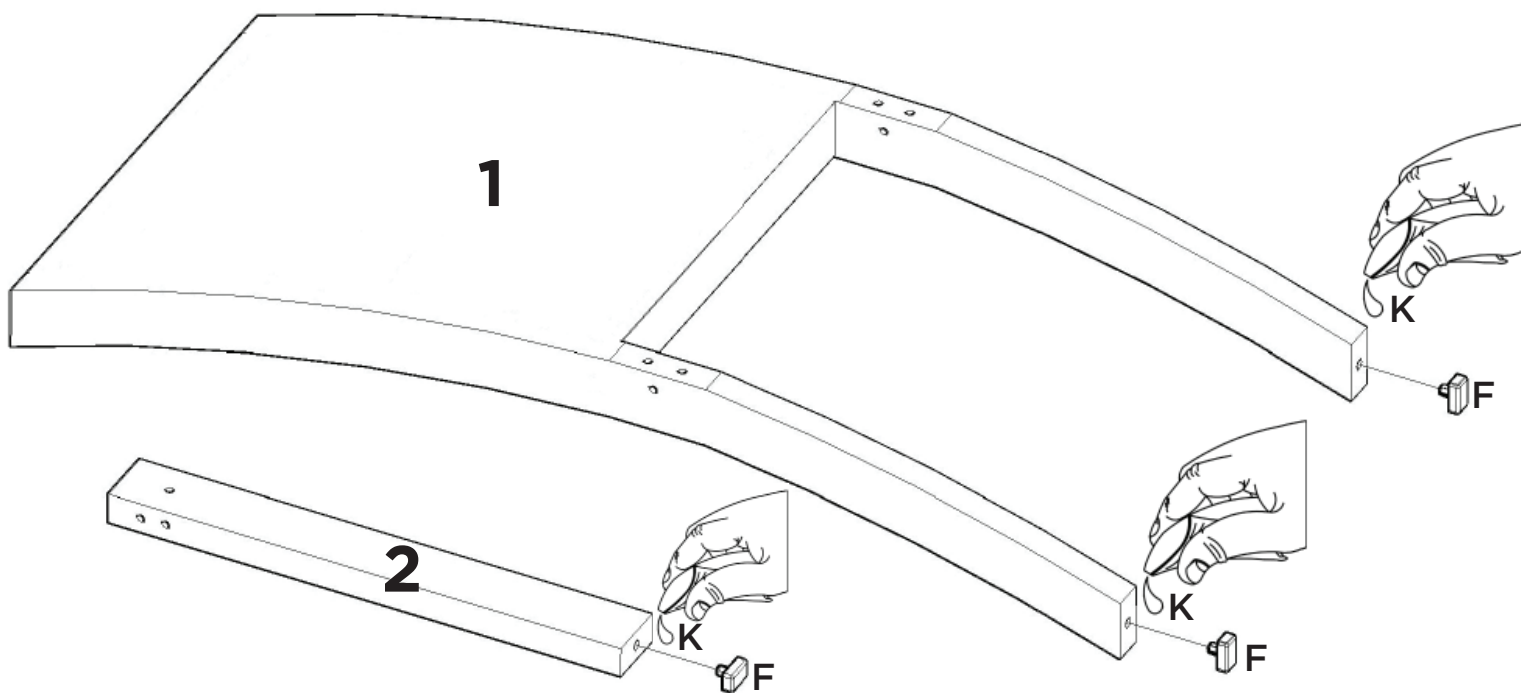
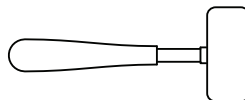



2 Pré Montagem Preasamblea | Pre-assembly

Peças Necessárias | Partes requeridas | Required Parts:

3	Travessa Lateral Plato lateral Side Platter	x12
4	Travessa Frontal Plato delantero Front Platter	x12
5	Moldura Superior Marco superior Top Frame	x6

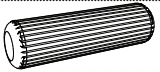
Ferragens | Herrajes | Hardware:

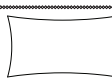
D		x12
E		x72
K		

Ferramentas | Instrumentos | Tools:

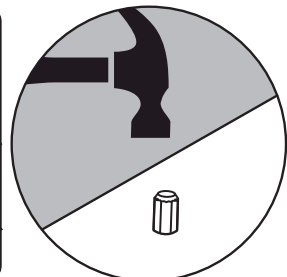
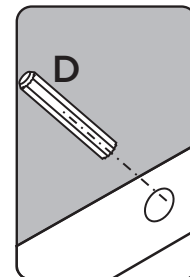
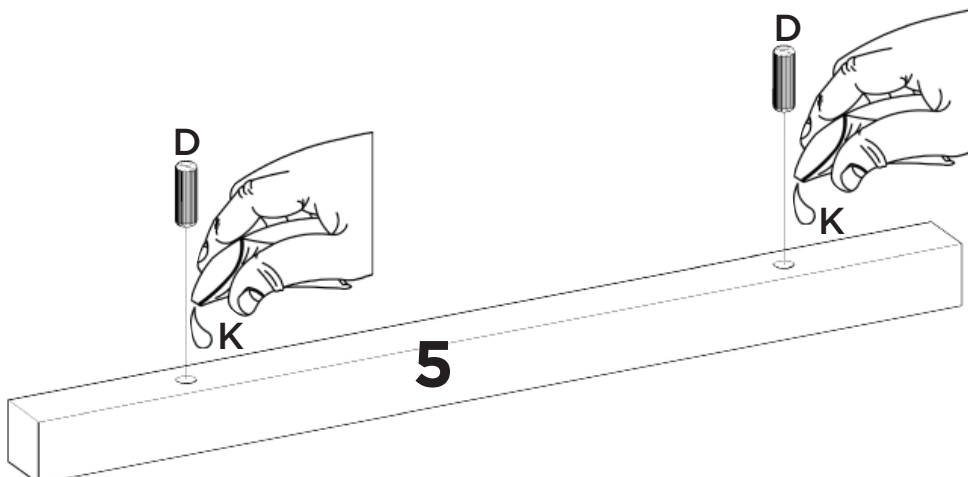
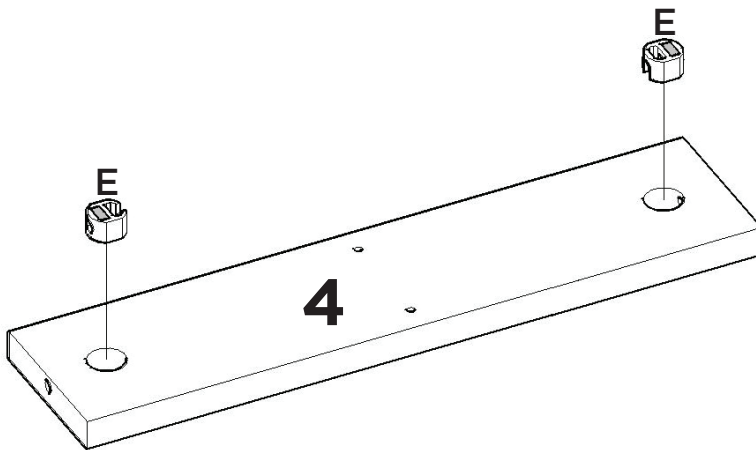
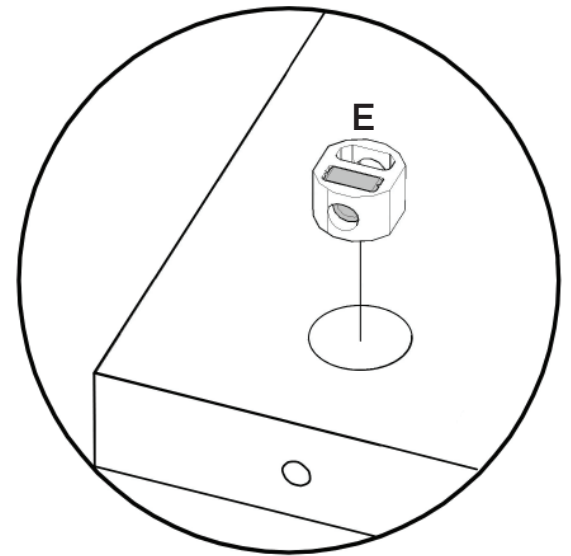
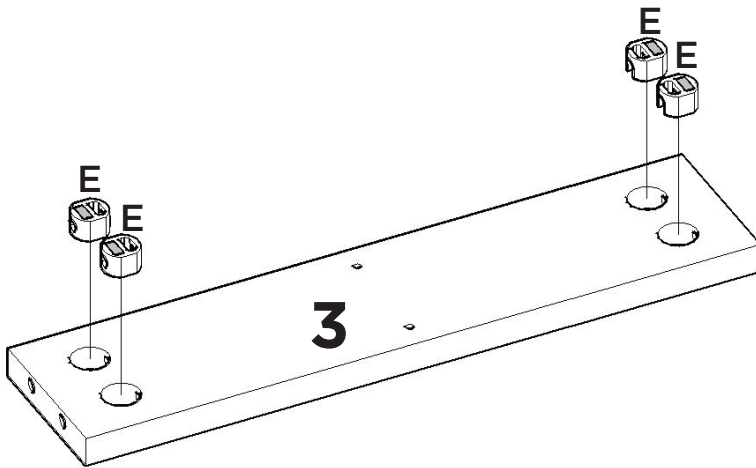
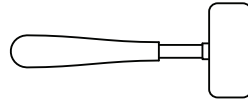



3

Peças Necessárias | Partes requeridas | Required Parts:

1	Encosto Respaldo Backrest	x6
2	Pé Frontal Pie delantero Front foot	x6
3	Travessa Lateral Plato lateral Side Platter	x6

Ferragens | Herrajes | Hardware:

A		x24
H		

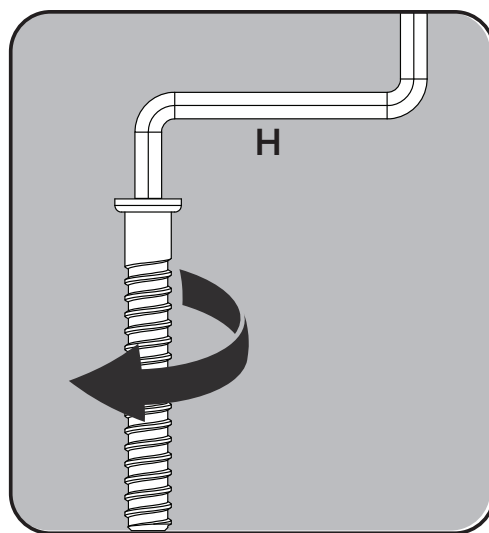
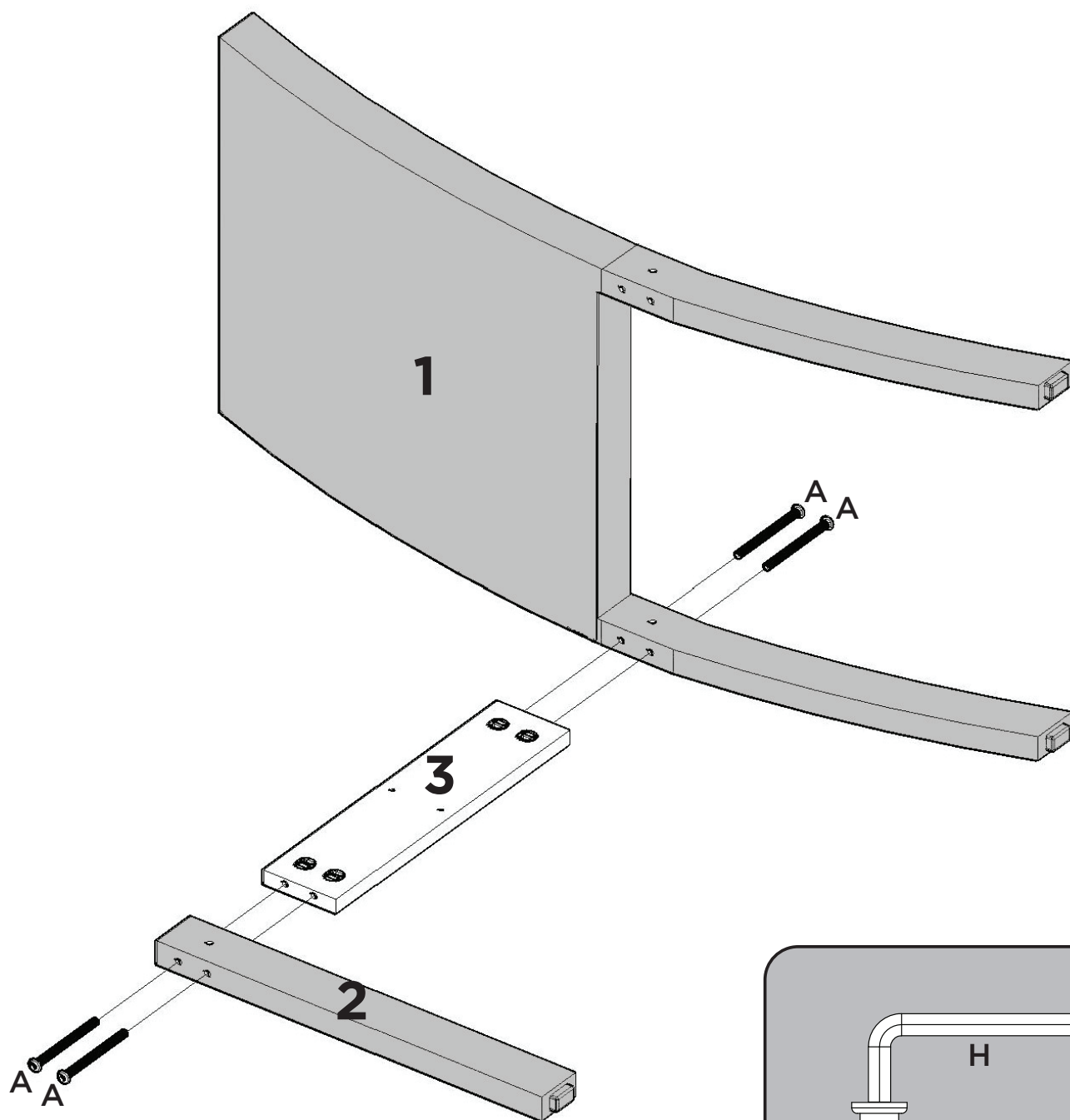



4

Peças Necessárias | Partes requeridas | Required Parts:

4	Travessa Frontal Plato delantero Front Platter	x6
---	--	----

Ferragens | Herrajes | Hardware:

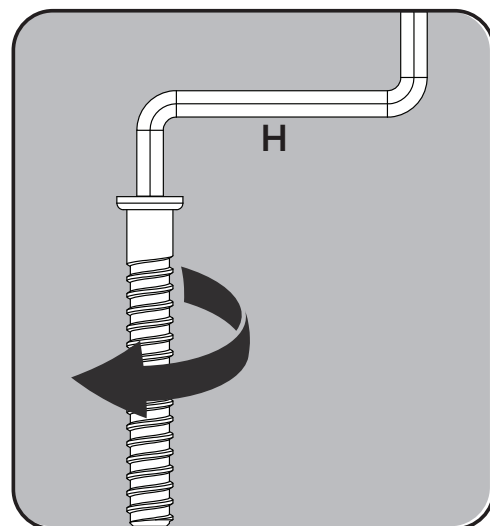
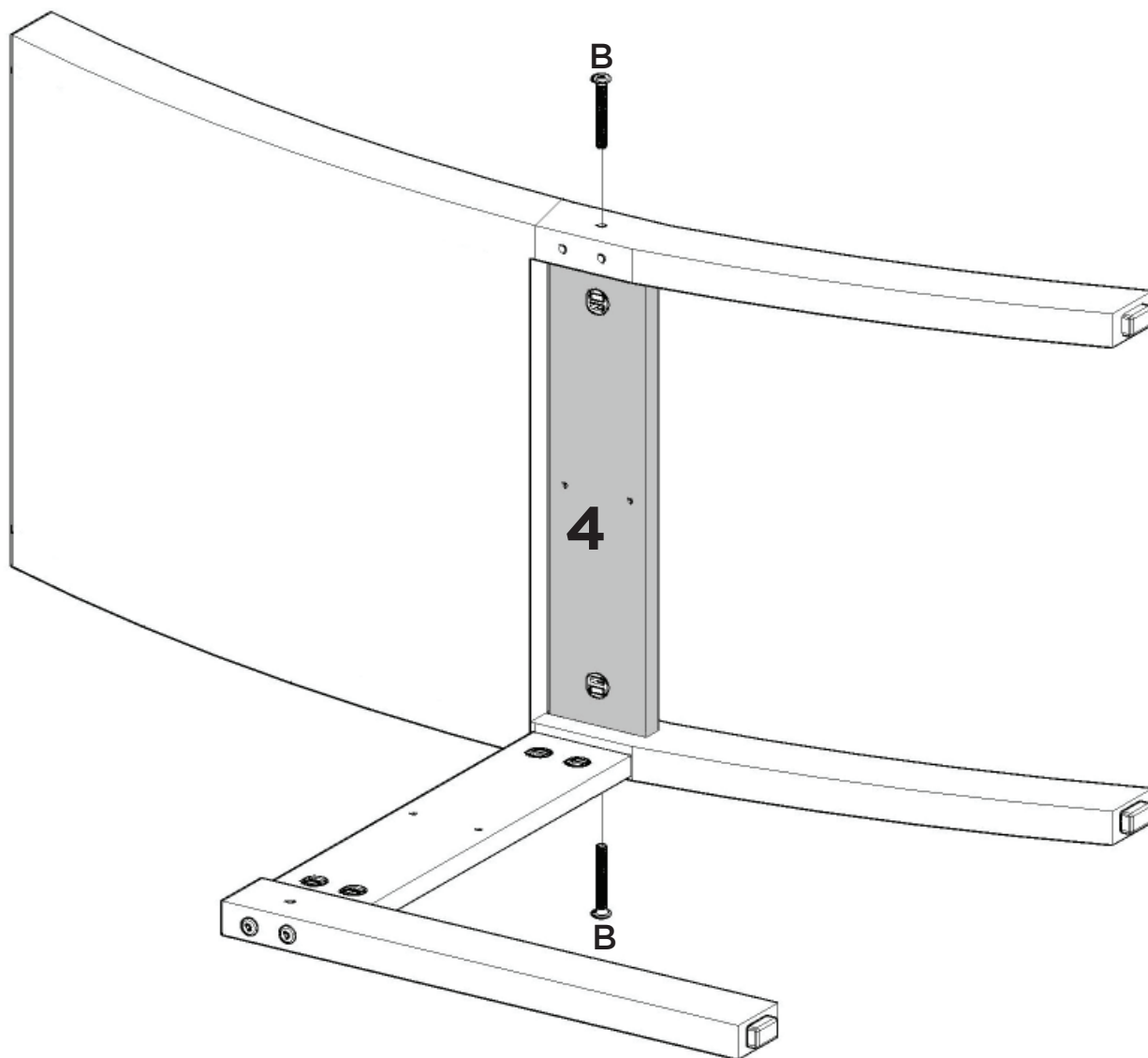

B		x12
H		



Peças Necessárias | Partes requeridas | Required Parts:

2	Pé Frontal Pie delantero Front foot	x6
3	Travessa Lateral Plato lateral Side Platter	x6

Ferragens | Herrajes | Hardware:

A		x24
H		

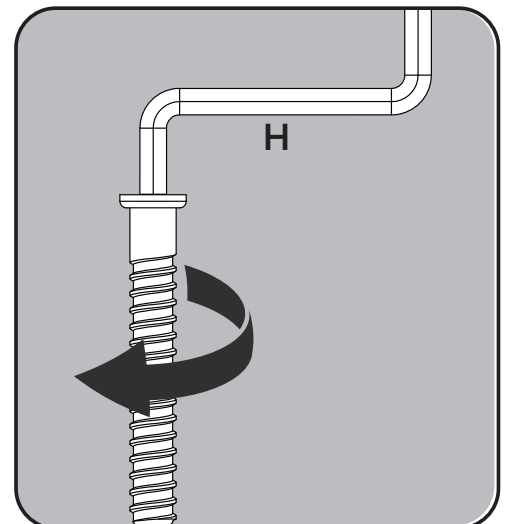
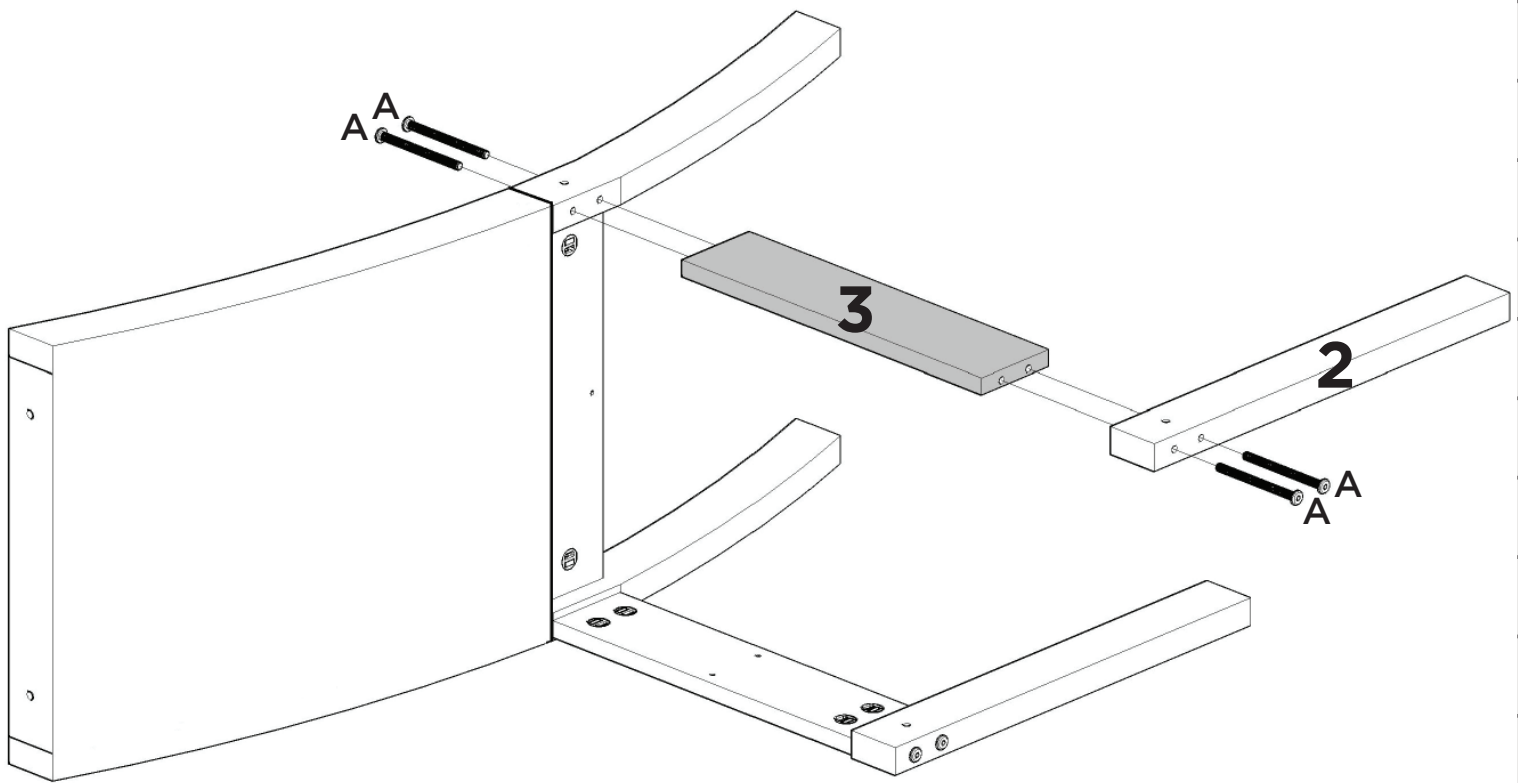



6

Peças Necessárias | Partes requeridas | Required Parts:

4	Travessa Frontal Plato delantero Front Platter	x6
---	--	----

Ferragens | Herrajes | Hardware:

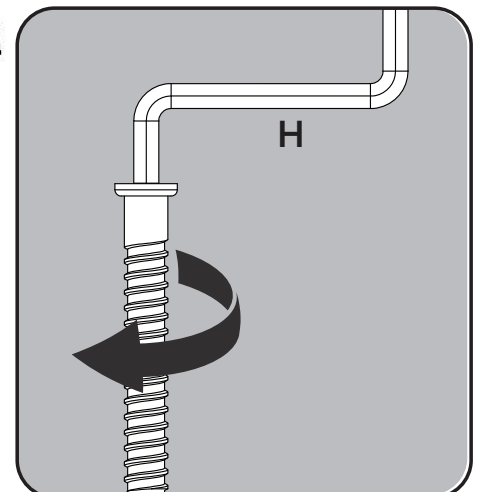
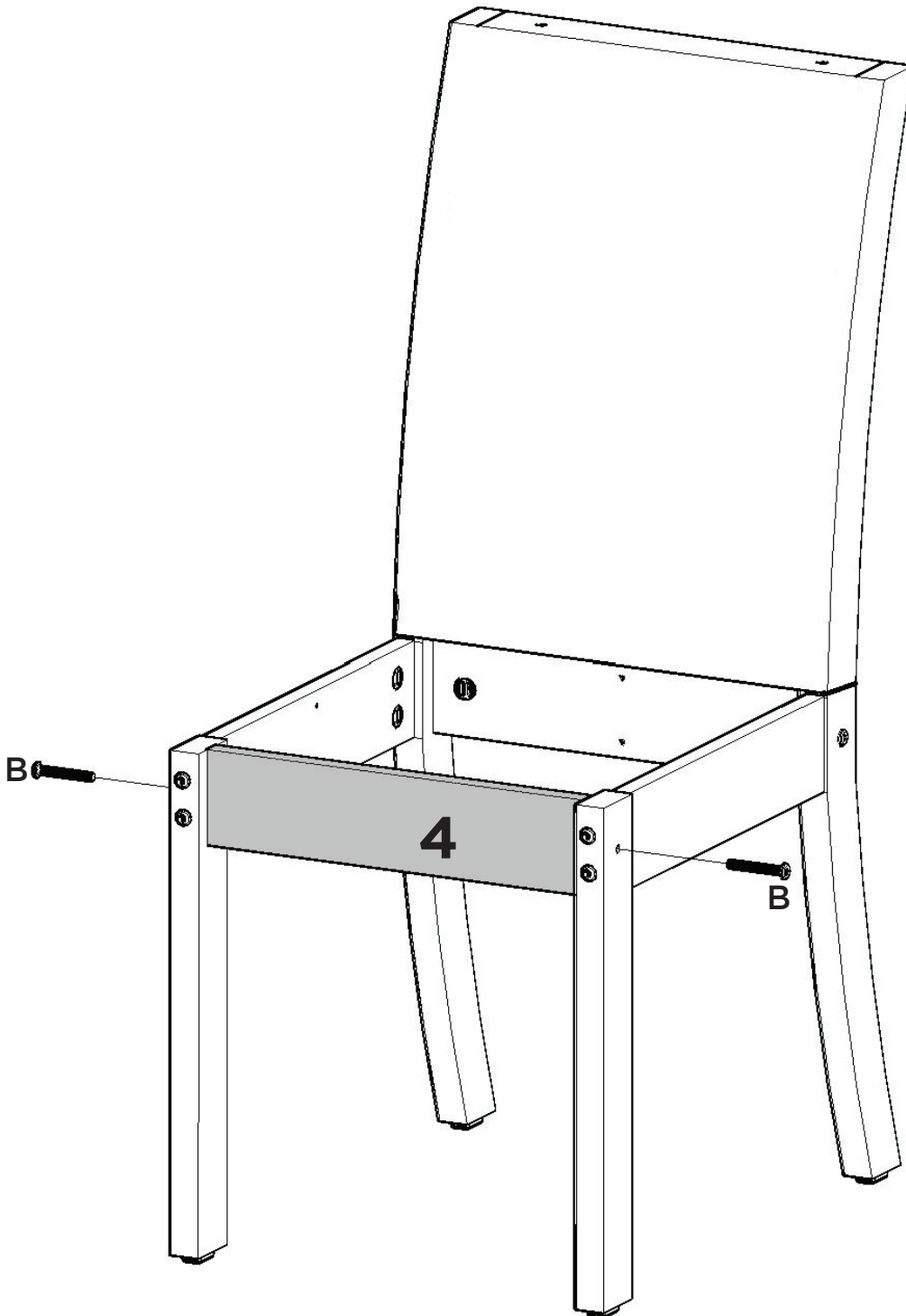

B		x12
H		



Peças Necessárias | Partes requeridas | Required Parts:

5	Moldura Superior Marco superior Top Frame	x6
---	---	----

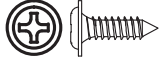
Ferragens | Herrajes | Hardware:

C		x24
G		x24
K		

Ferramentas | Instrumentos | Tools:

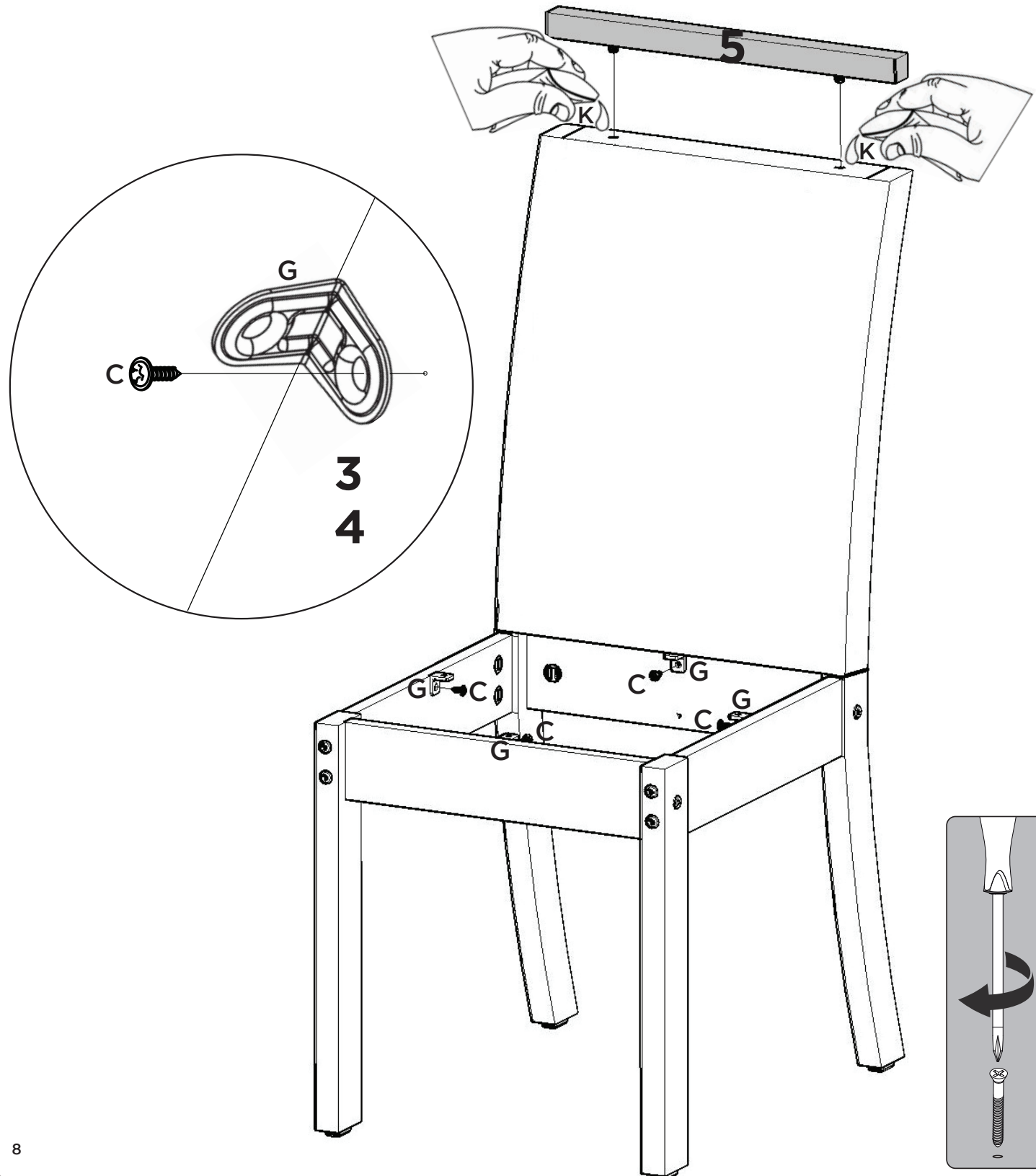
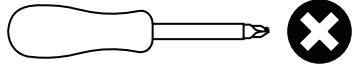

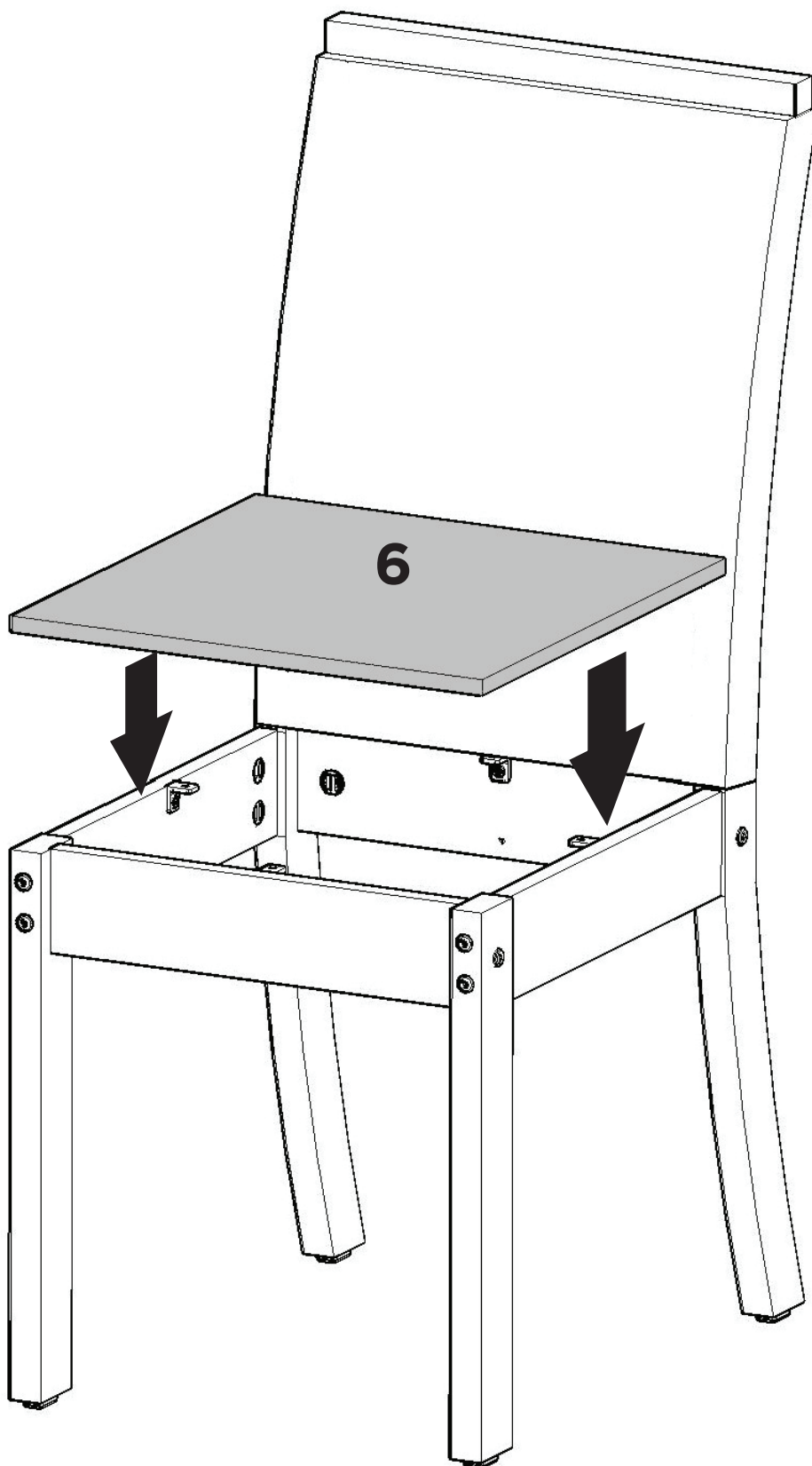

Peças Necessárias | Partes requeridas | Required Parts:

6	Assento Asiento Seat	x6
---	--------------------------	----



9

Ferragens | Herrajes | Hardware:

C	 	x24
---	---	-----

Ferramentas | Instrumentos | Tools:

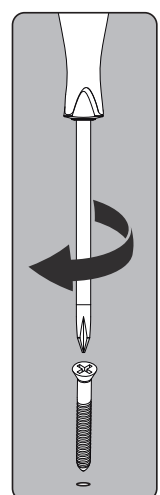
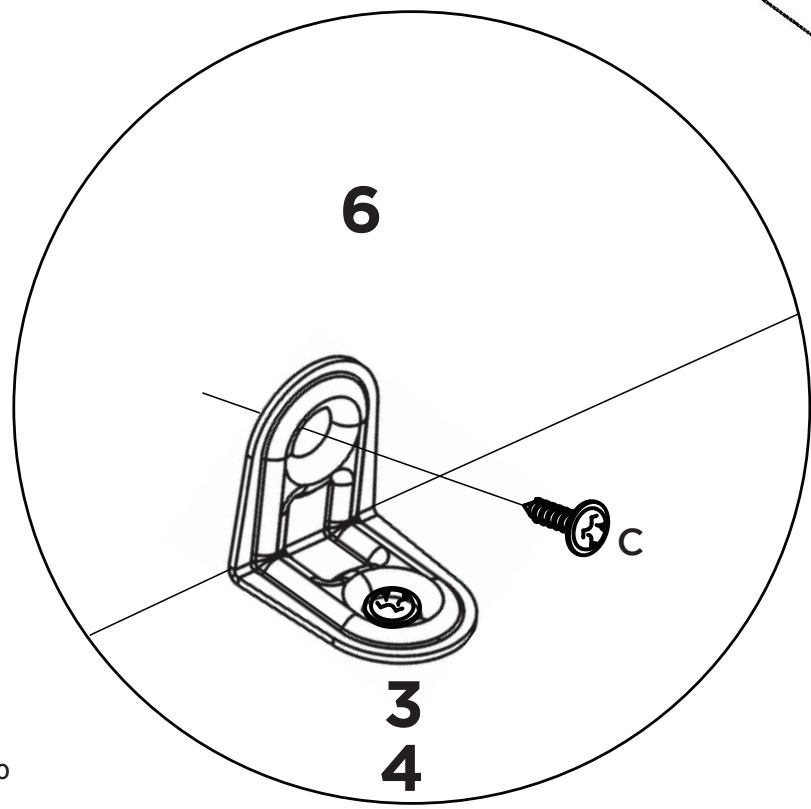
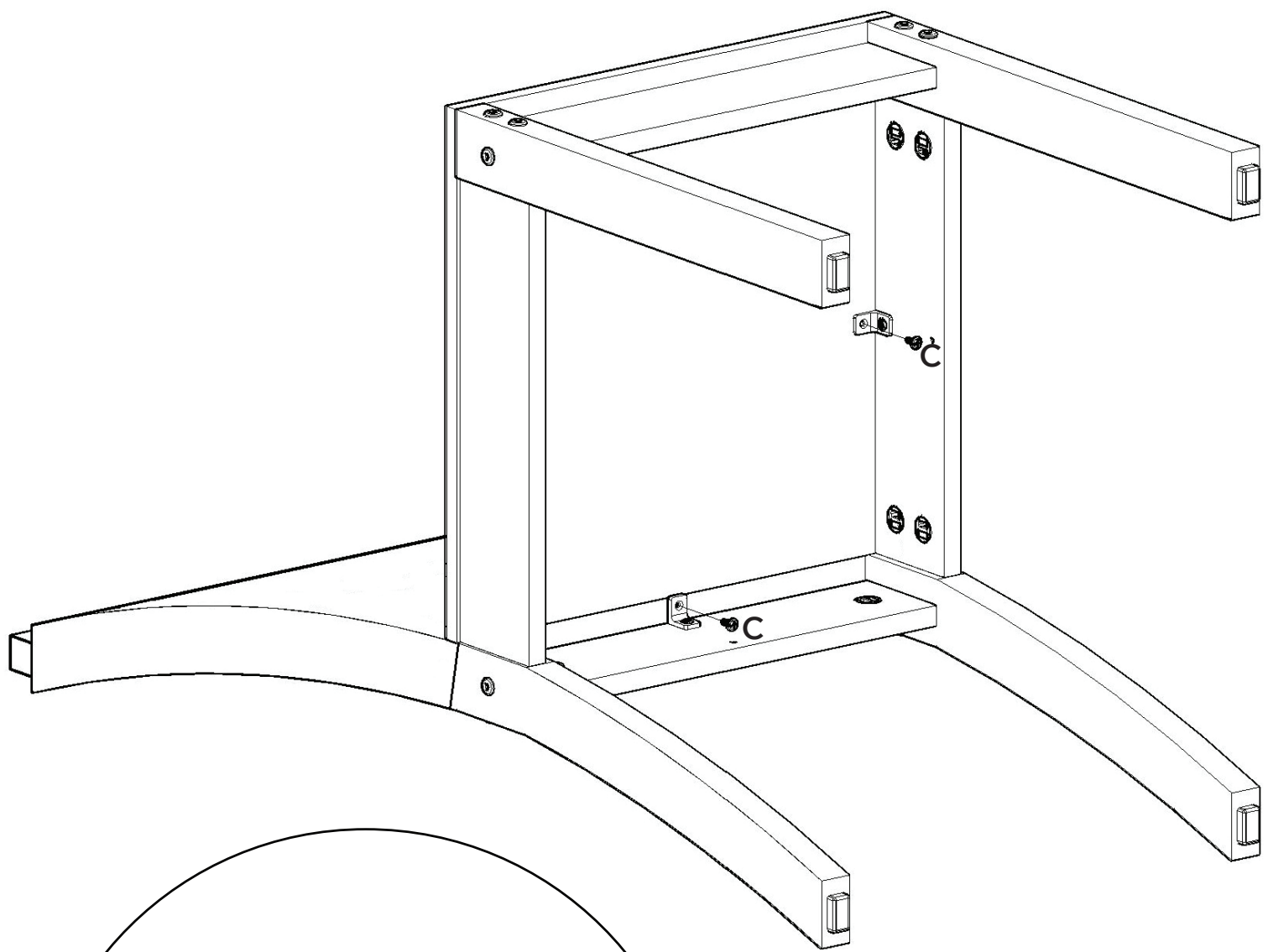
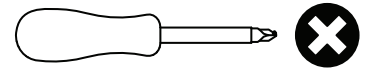

Ferragens | Herrajes | Hardware:

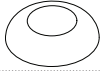
I		x72
---	---	-----

Pesos máximos recomendados com carga distribuída
Peso máximo recomendado con la carga distribuida
Recommended maximum weights with evenly distributed.

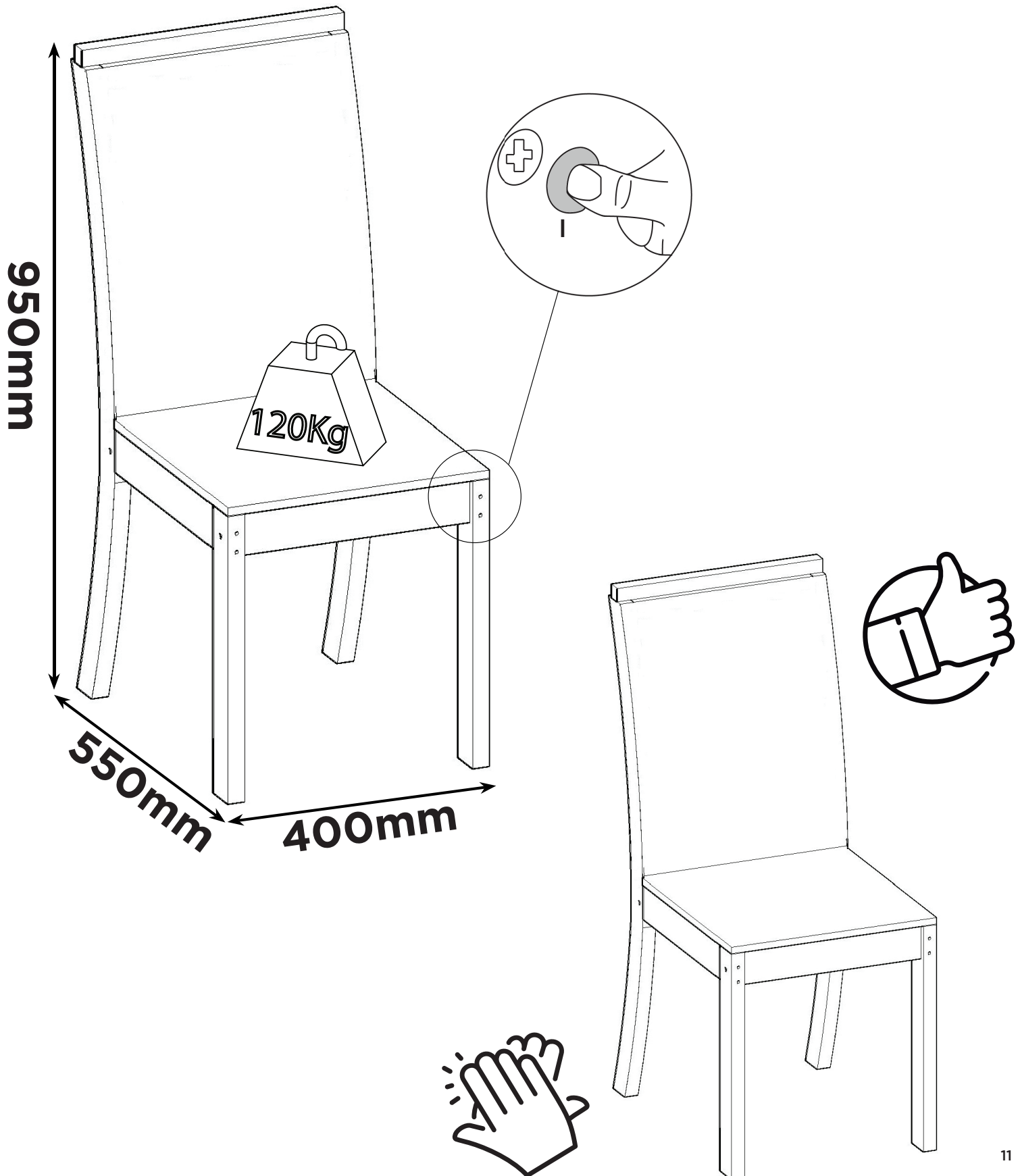





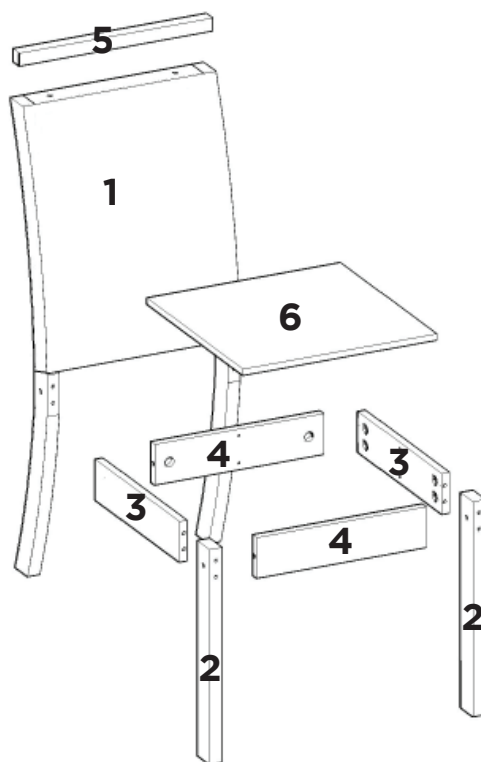

Item	Caixa Caja Box	Qtd Ctd Qty	Descrição Descripción Description	Medidas (mm) Dimensions (mm) Size (measurements) (mm)
1	1/1	06	Encosto Estofado Respaldo tapizado Upholstered backrest	925 x 400 x 155
2	1/1	12	Pé Frontal Pie delantero Front foot	425 x 50 x 25
3	1/1	12	Travessa Lateral Plato lateral Side Platter	345 x 80 x 15
4	1/1	12	Travessa Frontal Plato delantero Front Platter	345 x 80 x 15
5	1/1	06	Moldura Superior Marco superior Top Frame	395 x 25 x 25
6	1/1	06	Assento Estofado Asiento tapizado Upholstered seat	400 x 400 x 40

O volume contém peças para montagem de 6 Cadeiras.
 El volumen contiene piezas para montar 6 sillas.
 The volume contains parts for mounting 6 Chairs.

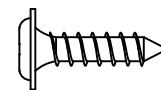
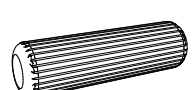

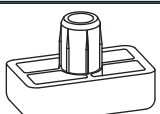
Ferragens | Herrajes | Hardware

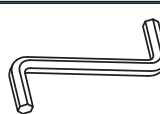
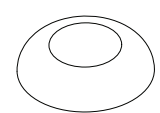
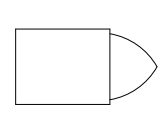
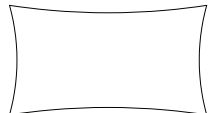
<p>A 48x</p>  <p>Parafuso Cab PL 17 Allen 4.14x3,12 (90mm) Tornillo PL 17 Allen 4.14x3.12 (90mm) Screw PL 17 Allen 4.14x3.12 (90mm)</p>	<p>B 24x</p>  <p>Parafuso Cab PL 17 Allen 4.14x3,12 (60mm) Tornillo PL 17 Allen 4.14x3.12 (60mm) Screw PL 17 Allen 4.14x3.12 (60mm)</p>	<p>C 48x</p>  <p>Parafuso 3,5x14mm FLA. Tornillo 3,5x14mm FLA. Screw 3,5x14mm FLA.</p>	<p>D 12x</p>  <p>Cavilha Madeira 10x35mm Taco de madeira de 10x35 mm 10x35mm wooden dowel</p>
<p>E 72x</p>  <p>Porca meia lua plástica rosca 1/4 1/4 tuerca de media luna de plástico 1/4 plastic half moon nut</p>	<p>F 24x</p>  <p>Sapata Deslizante 15x26x8mm Zapato deslizante 15x26x8mm Sliding Shoe 15x26x8mm</p>	<p>G 24x</p>  <p>Cantoneira Metal 18x18mm 18x18mm esquina de metal Soporte Metal Corner Bracket 18x18mm</p>	<p>H 01x</p>  <p>Chave Allen llave Allen Allen key</p>
<p>I 72x</p>  <p>Tapa Parafuso Soft 17mm Tapón de rosca suave de 17 mm Soft Screw Cap 17mm</p>	<p>J 01x</p>  <p>Giz de correção Tiza de corrección Chalk of correction</p>	<p>K 02x</p>  <p>Sachê de cola Bolsa de pegamento Glue bag</p>	

HENN

Ind. e Com. de Móveis Henn
Mondai - SC - Brasil

+55 49 3674.3500

@moveishenn
www.henn.com.br

INSTRUÇÕES DE MONTAGEM

INSTRUCCIONES DE MONTAJE
ASSEMBLY INSTRUCTIONS

Mesa Vértice 1600mm | Vértice Mesa 1600mm | Vértice Table 1600mm

S203-127 Nature/OFF White

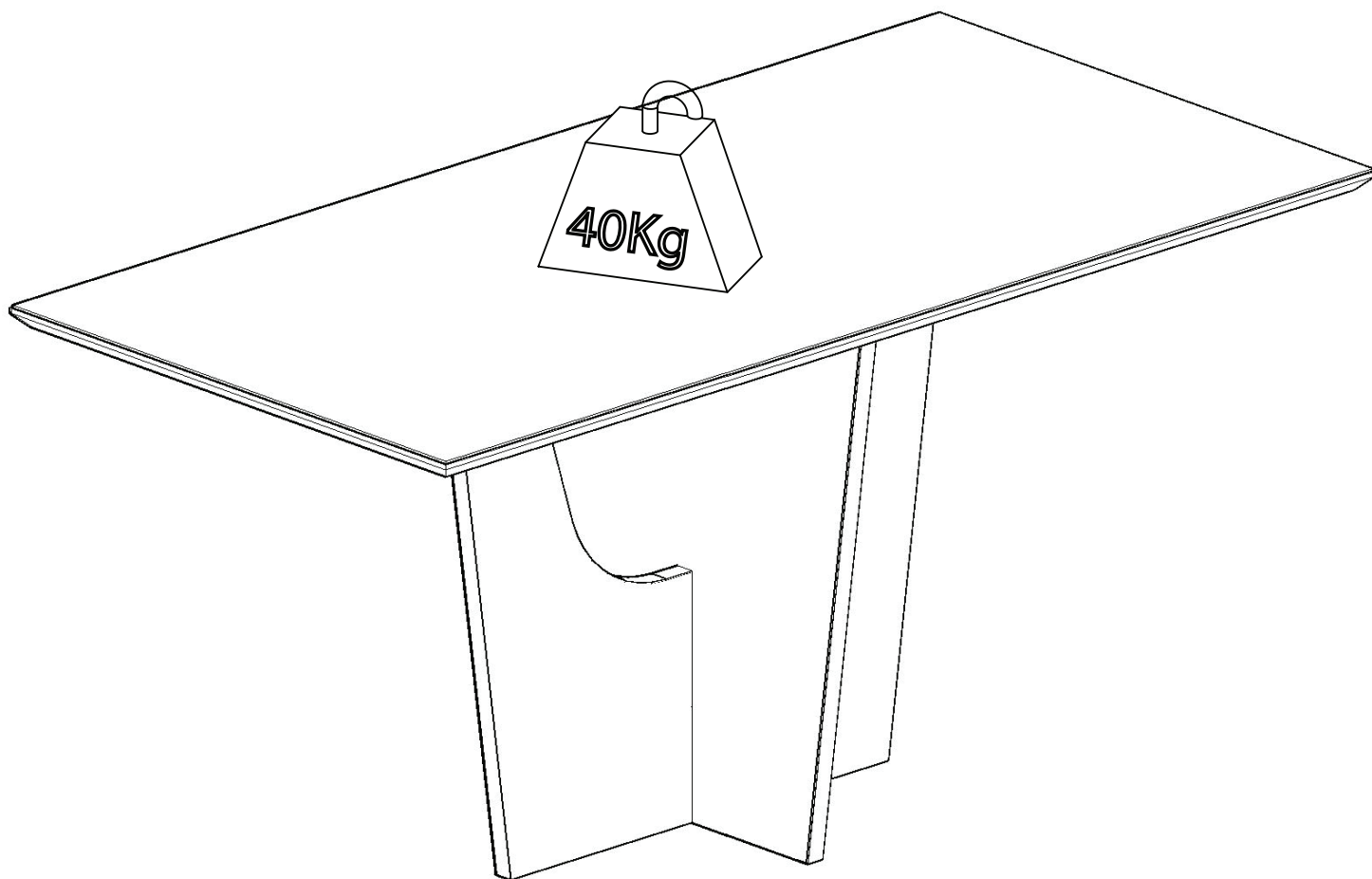

Pesos máximos recomendados com carga distribuída
Peso máximo recomendado con la carga distribuida
Recommended maximum weights with evenly distributed.

Requisitos para montagem
Requisitor para la montaje
Assembly Requirements

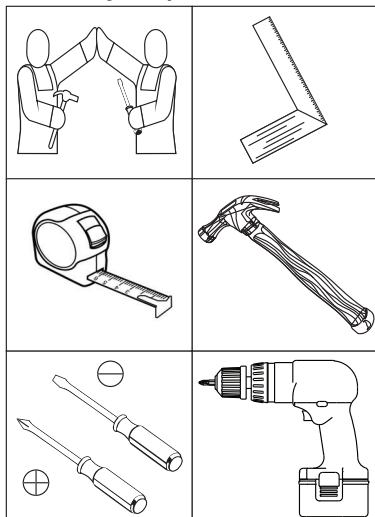

Imagens meramente ilustrativas
Imágenes meramente ilustrativas
Images for illustration only

AVISO

Para limpeza de seu móvel, use uma flanela seca ou umedecida, e não utilize produtos químicos que possam danificar seu produto.

SISTEMA DE MONTAGEM

O sistema de montagem dos produtos, funciona de acordo com a ordem crescente dos números indicados no desenho. Ex: 01, 02, 03, 04... até a conclusão da montagem.

ADVERTENCIA

Para limpieza de su móvil, use una flanela seca o húmeda, y no utilice productos químicos que puedan dañar su producto.

SISTEMA DE MONTAJE

El sistema de montaje de los productos funciona de acuerdo con el orden creciente de los números indicados en el dibujo. Ej.: 01, 02, 03, 04... hasta la conclusión del montaje.

NOTICE

To clean your furniture, use a dry or wet cloth, and do not use chemicals that may damage your product.

ASSEMBLY SYSTEM

The products' assembly system works according to the increasing order of the indicated numbers. For example: 01, 02, 03, 04 ... to the end of the assembly.

1

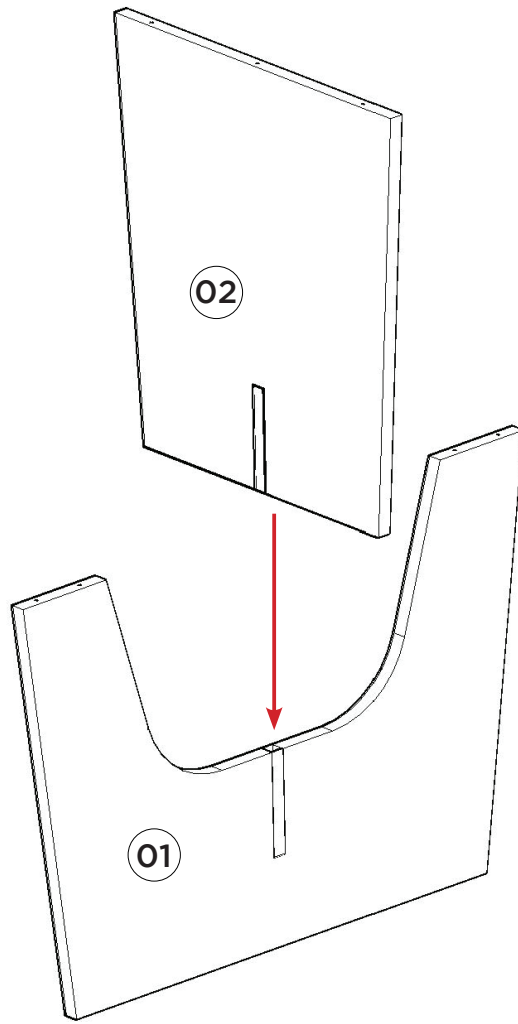

2

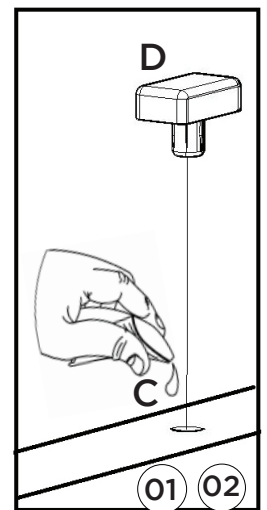
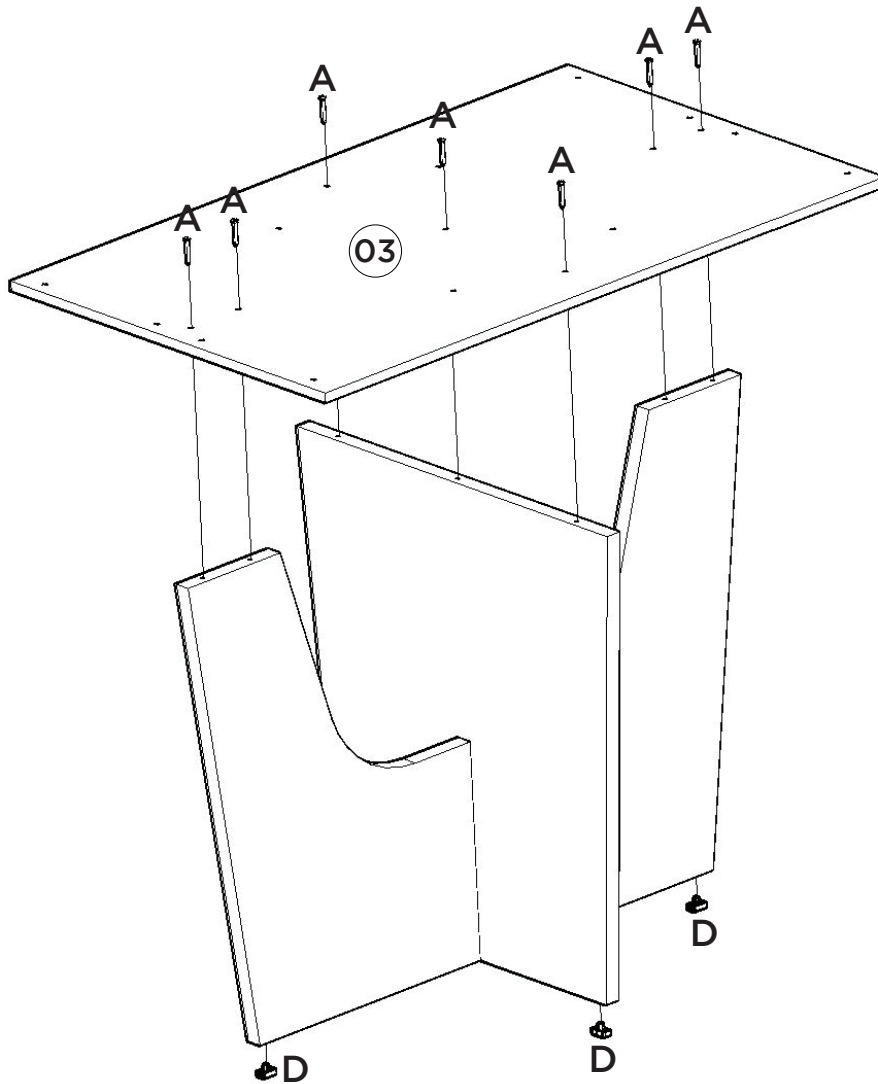

3

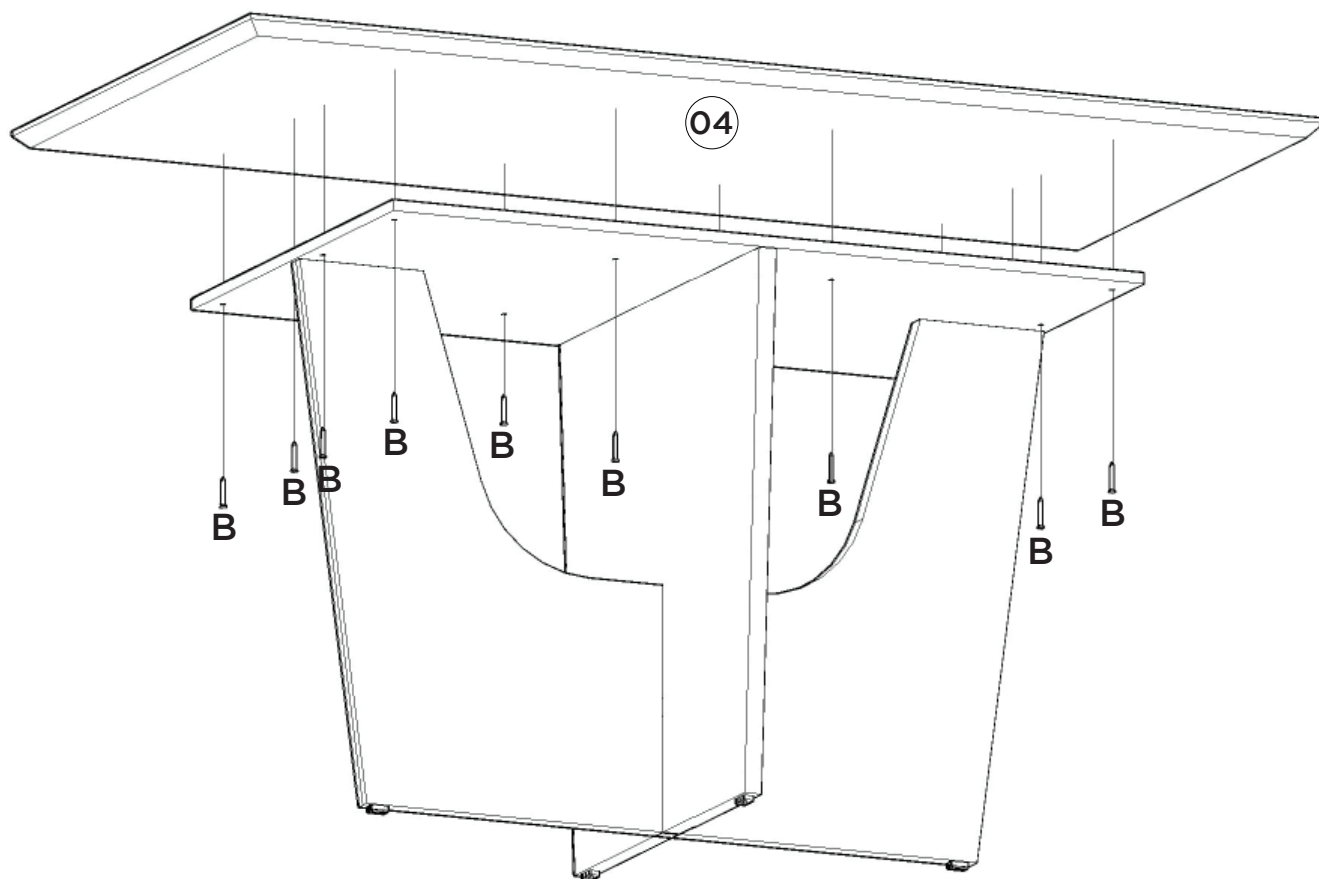

4

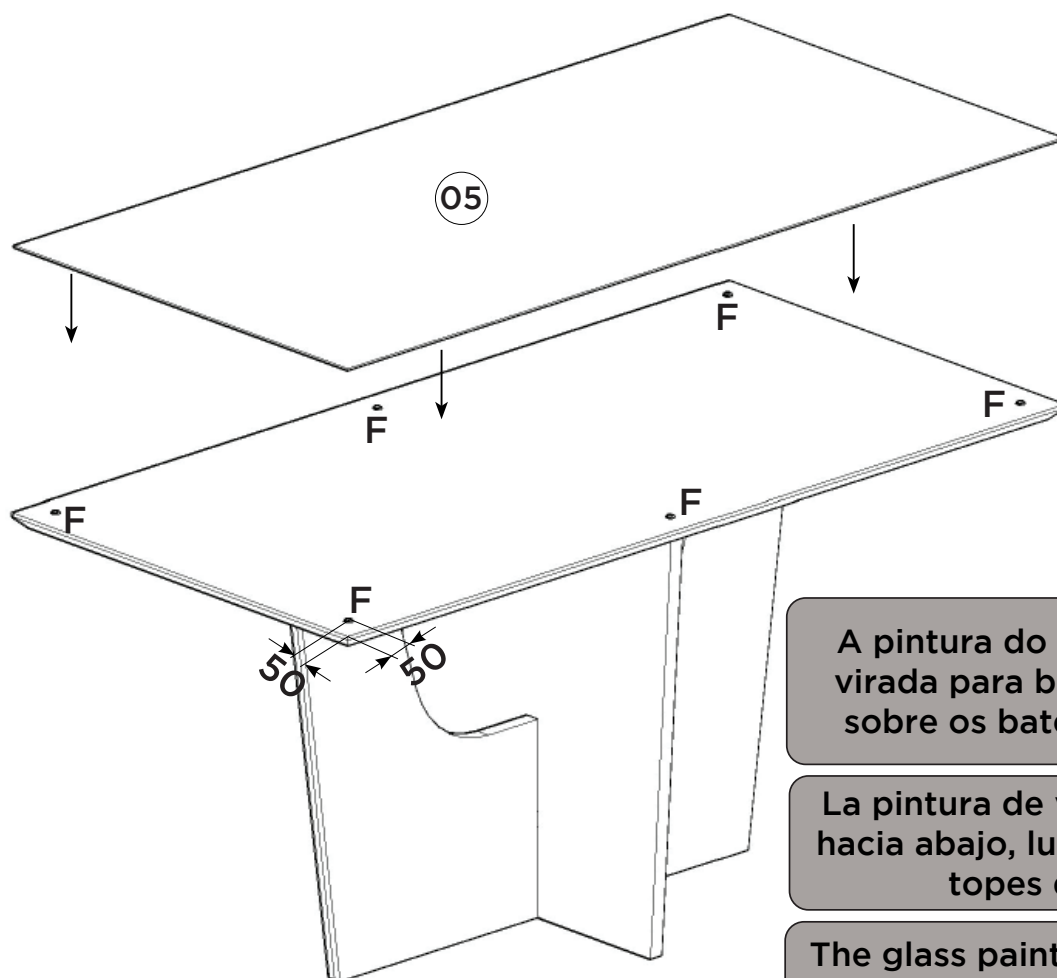

A pintura do Vidro (05) deve ficar virada para baixo, depois ajustá-lo sobre os batentes de silicone (F).

La pintura de vidrio (05) debe mirar hacia abajo, luego ajustarla sobre los toques de silicona (F).

The glass paint (05) should be facing downwards, then adjust it over the silicone stops (F).

Item	Caixa Caja Box	Qty Ctd Qty	Descrição Descripción Description	Medidas (mm) Dimensions (mm) Size (measurements) (mm)
01	2/2	01	Lateral Maior Lateral mayor Greater lateral	1110x751x25
02	2/2	01	Lateral Menor Lado menor Minor Side	751x665x25
03	2/2	01	Tampo Estrutural Tapa estructural Structural Top	1120x675x15
04	1/2	01	Tampo Tapa Top	1598x798x25
05	1/2	01	Vidro com Pintura Vidrio con pintura Glass with Painting	1598x798x4

Ferragens | Herrajes | Hardware

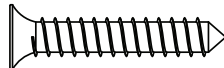
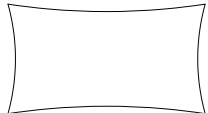
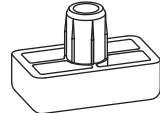
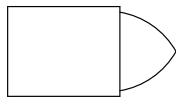
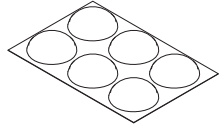
<p>A 07x</p>  <p>Parafuso 3,5x40mm CHT. Tornillo 3,5x40mm CHT. Screw 3,5x40mm CHT.</p>	<p>B 12x</p>  <p>Parafuso 4,0x25mm CHT. Tornillo 4,0x25mm CHT. Screw 4,0x25mm CHT.</p>	<p>C 01x</p>  <p>Sachê de cola Bolsa de pegamento Glue bag</p>	<p>D 04x</p>  <p>Sapata Deslizante 15x26x8mm Zapato deslizante 15x26x8mm Sliding Shoe 15x26x8mm</p>
<p>E 02x</p>  <p>Giz de correção Tiza de corrección Chalk of correction</p>	<p>F 01x</p>  <p>Kit Batente silicone (6 unidades) tapón de silicona Kit (6 unidades) Kit silicone stopper (6 units)</p>		