

# MESA URCA 1500X800

## FICHA TÉCNICA

## CÓDIGOS DE PEÇAS

## FERRAMENTAS NECESSÁRIAS

Nº	DESCRIÇÃO	MEDIDAS (mm)	QUANTIDADE	RÚSTICO	CANELA
1	Travessa	850x210x15	1	5011731578	5011731530
2	Lateral maior da travessa	388x770x12	2	5011701478	5011701430
3	Lateral menor	80x770x15	4	5011701278	5011701230
4	Lateral maior da travessa	388x770x12	2	5011701378	5011701330

TAMPOS	RÚSTICO	CANELA	BRANCO	OFF-WHITE
5A Tampo Urca	1500x800x40	1	5011660178	5011660130
5B Tampo Primus (p/ vid incolor)	1500x800x25	1	5011890184 (sup preta)	5011890132 (sup preta)
5B Tampo Isis (p/ vid pintado)	1500x800x25	1	5011975578	5011975530
			5011890151	5011890152
			5011975551	5011975552

VIDROS	INCOLOR	BRANCO	PRETO	OFF-WHITE
6 Vidro retangular	1500x800x4	1	409056	409069
			409070	409071

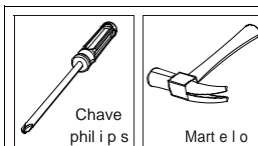

**Não utilizar furadeira. Se usar parafusadeira, defina o torque máximo em 10 para evitar danos ao produto.**

## FERRAGENS E ACESSÓRIOS

A x18		Cavilha 8x30mm	B x28		Parafuso Philips 5x40mm	C x24		Tapa-furo 13mm	D x8		Sapata 14x4mm
E x8		Prego 8x8	F x4		Cantoneira 18x18mm	G x8		Parafuso Philips 3,5x14mm	H x9		Silicone adesivo

### PASSO 1

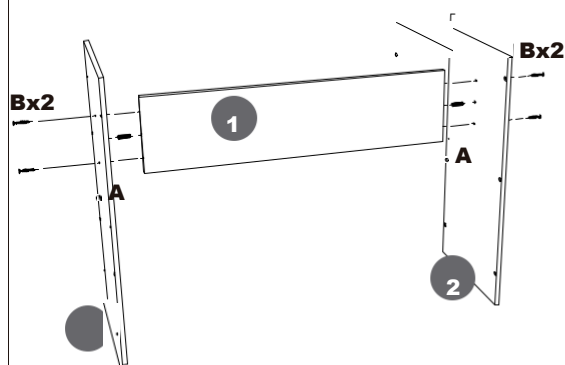

Junte a travessa (1) e as laterais maiores da travessa (2) e fixe-as utilizando os parafusos 5x40 (B).

### PASSO 2

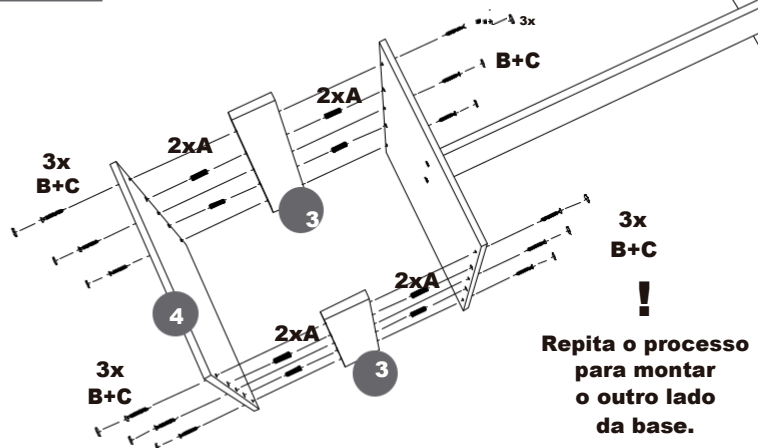

Junte a lateral maior (4) às laterais menores (3) e à lateral maior da travessa (2) utilizando as cavilhas (A) como auxílio. Fixe tudo utilizando os parafusos 5x50 (B) e tampe-s utilizando os tapa-furos (C).

### PASSO 3

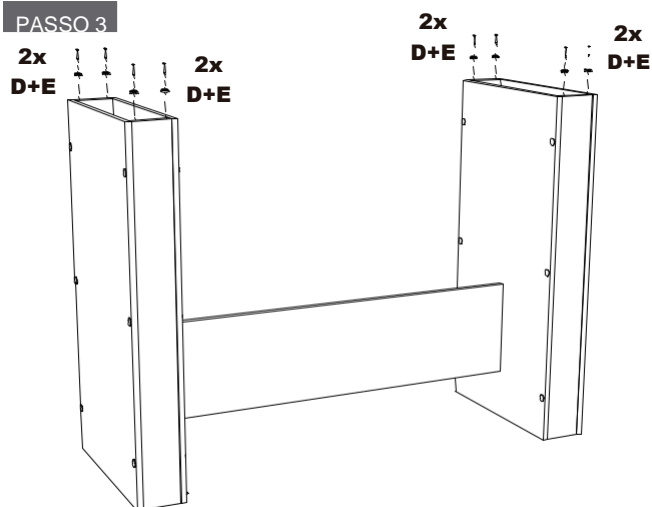

Fixe as sapatas (D) utilizando os pregos (E).

**!**  
Vire a página para a montagem dos tampo de acordo com as suas variações.

PASSO 4

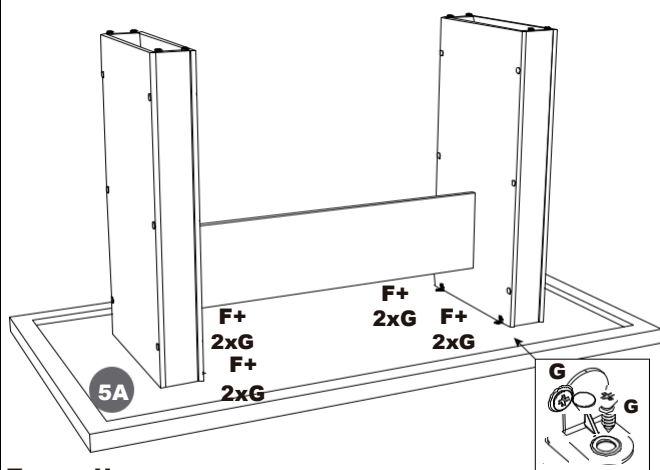

**Tampo Urca**

Centralize a base no tampo da mesa e fixe-a utilizando as cantoneiras (F) e os parafusos 3,5x14 (G).

PASSO 4

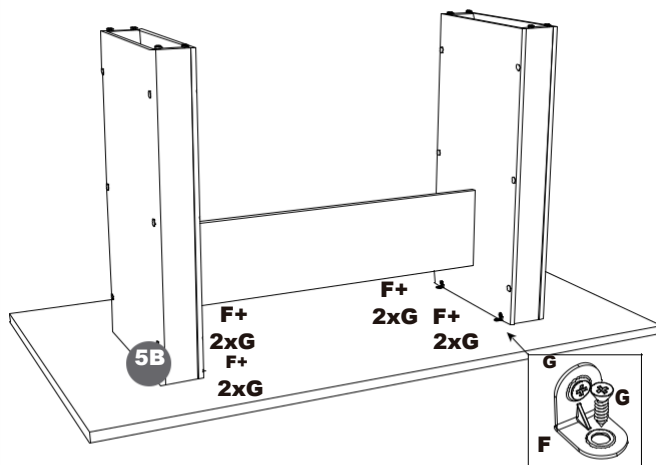

**Tampo Primus ou Isis**

Centralize a base no tampo da mesa e fixe-a utilizando as cantoneiras (F) e os parafusos 3,5x14 (G).

CONCLUÍDO

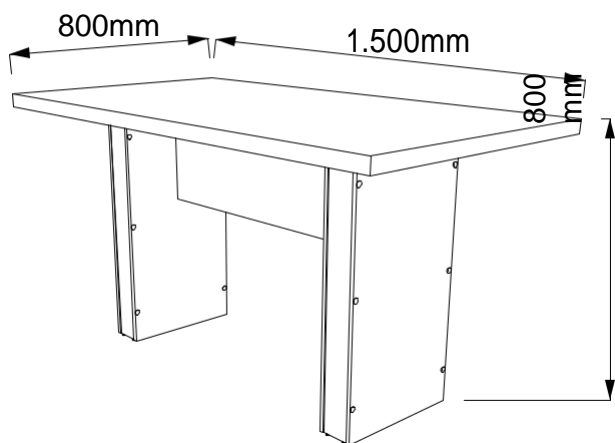

PASSO 5

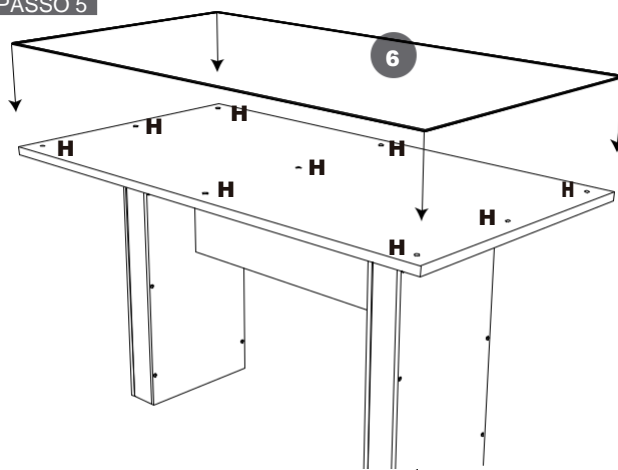

Cole o silicone adesivo (H) sobre o tampo da mesa conforme indicado na imagem e depois centralize o vidro (6) sobre o tampo.

CONCLUÍDO

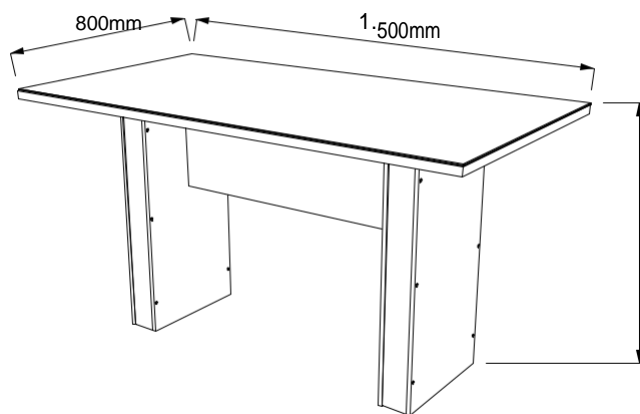

# CADEIRA ALICE

## FICHA TÉCNICA







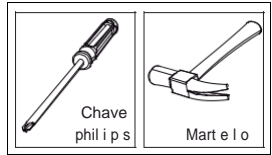

## CÓDIGOS DE PEÇAS

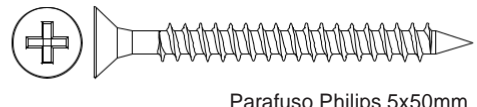
## FERRAMENTAS NECESSÁRIAS

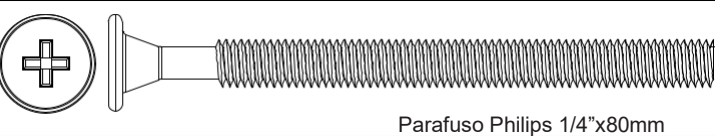
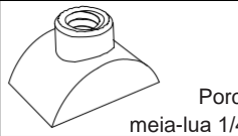
Nº	DESCRIÇÃO	MEDIDAS (mm)	QUANTIDADE	BRANCA	CANELA	GRISS	RÚSTICO	CARVALHO	CASTANHO
1	Encosto	340x455x40	1	5012580500	5012580500	5012580500	5012580500	5012580500	5012580500
2	Travessa do encosto superior	340x120x25	1	5012690651	5012690630	5012690640	5012690678	5012690690	5012690698
3	Travessa da lateral	340x90x18	2	5012570951	5012570930	5012570940	5012570978	5012570990	5012570998
4	Pé traseiro esquerdo	125x970x25	1	5012571051	5012571030	5012571040	5012571078	5012571090	5012571098
5	Pé traseiro direito	125x970x25	1	5012571151	5012571130	5012571140	5012571178	5012571190	5012571198
6	Pé frontal	45x430x25	2	5012570851	5012570830	5012570840	5012570878	5012570890	5012570898
7	Travessa inferior	340x80x18	2	5012570351	5012570330	5012570340	5012570378	5012570390	5012570398
8	Assento	410x410x40	1	5012570700	5012570700	5012570700	5012570700	5012570700	5012570700

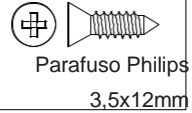

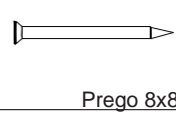
## FERRAGENS E ACESSÓRIOS

A x4	 Furadeira 8x30mm	B x12	 Parafuso Philips 5x50mm	C x12	 Tapa-furo 13mm	D x8	 Arruela 1/4x5/8"
E x8	 Parafuso Philips 1/4"x80mm	F x8	 Porca meia-lua 1/4"	G x8	 Tampa do parafuso 1/4xmm		
H x3	 Cantoneira 18x18mm	I x6	 Parafuso Philips 3,5x12mm	J x4	 Sapata 14x4mm	K x4	 Prego 8x8
L x8	 Porca cilíndrica 12x10						

### PASSO 1

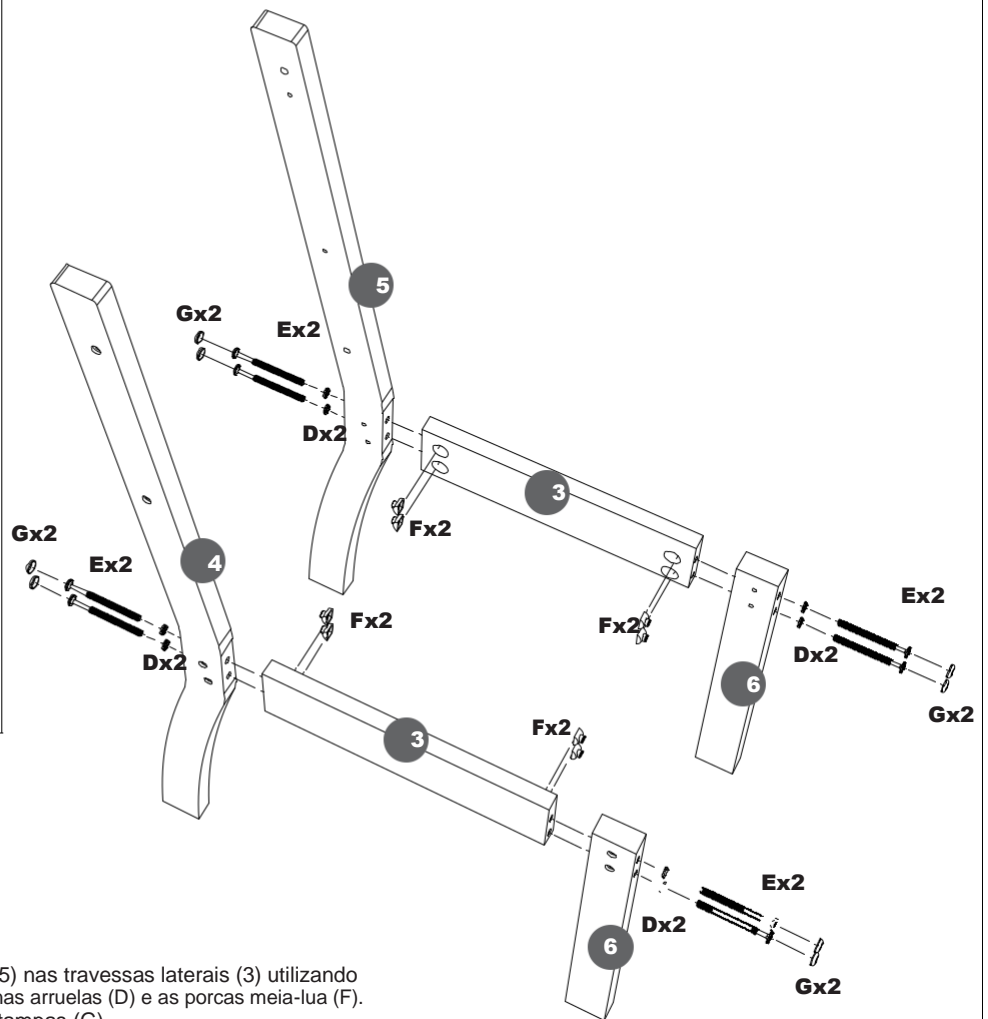
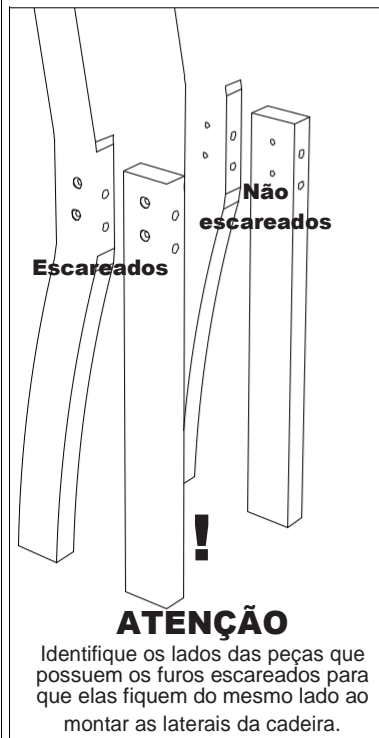

Fixe os pés frontais (6) e traseiros (4 e 5) nas travessas laterais (3) utilizando os parafusos 1/4"x80mm (E) já inseridos nas arruelas (D) e as porcas meia-lua (F). Depois, cubra os parafusos usando as tampas (G).

**PASSO 2**

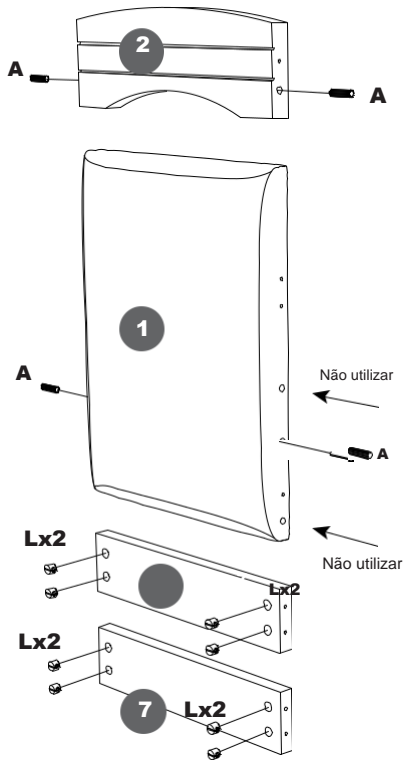

Encaixe as cavilhas (A) e as porcas cilíndricas (L) nos locais indicados.

**PASSO 3**



**ATENÇÃO**

Verifique o alinhamento das porcas cilíndricas (L) antes de apertar os parafusos.

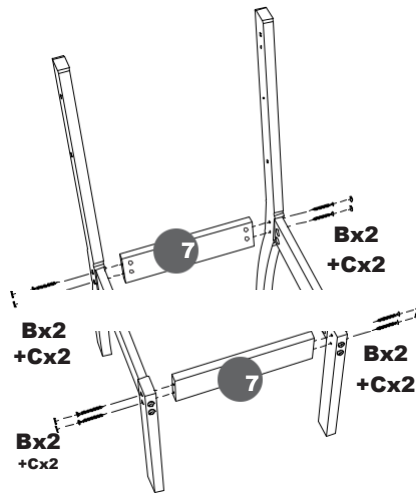

Utilizando os parafusos 5x50 (C), fixe as travessas inferiores (7) nos locais indicados. Depois, cole os tapa-furos (C).

**PASSO 4**

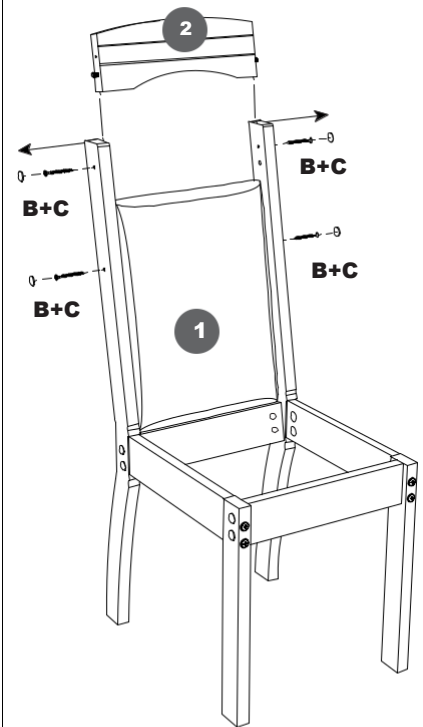

Abra levemente as laterais da cadeira para encaixar o encosto (1) e a travessa do encosto (2). Depois fixe-as utilizando os parafusos 5x50 (B) e cubra-os utilizando os tapa-furos (C).

**PASSO 5**

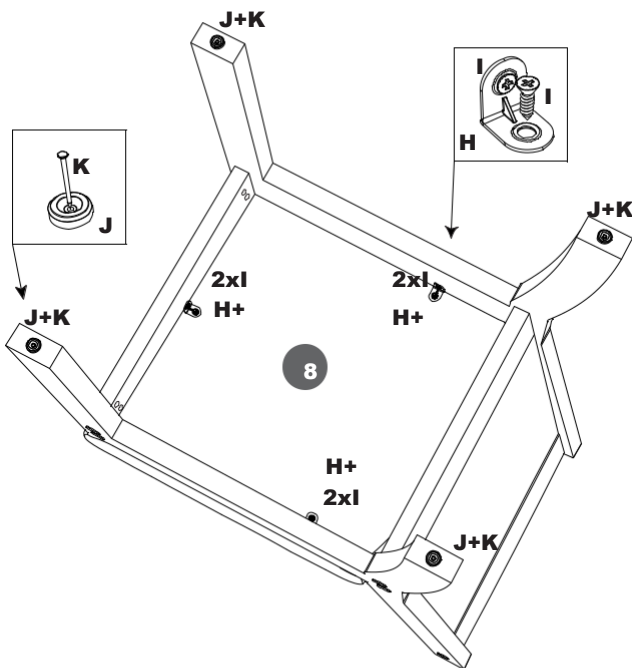

Encaixe o assento (8) na estrutura da cadeira e fixe-o utilizando as cantoneiras (H) e os parafusos 3,5x12 (I). Depois fixe as sapatas (J) nos pés da cadeira utilizando os pregos 8x8 (K).

**CONCLUÍDO**

