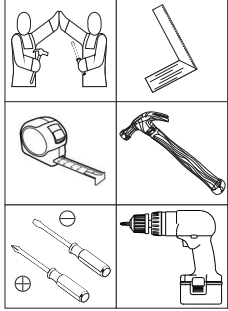
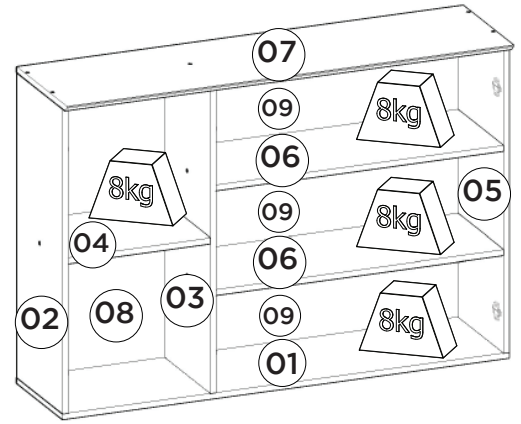
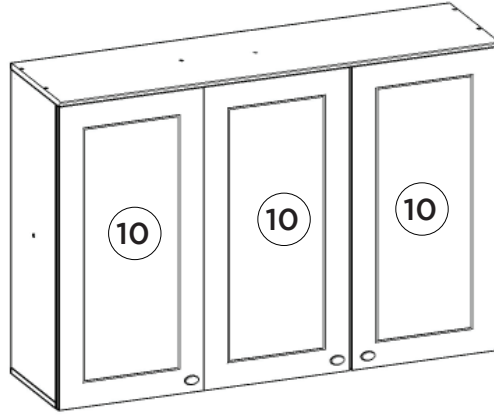

**HENN**Ind. e Com. de Móveis Henn  
Mondai - SC - Brasil

☎ +55 49 3674.3500

📷 @moveishenn  
www.henn.com.br**INSTRUÇÕES DE MONTAGEM****INSTRUCCIONES DE MONTAJE  
ASSEMBLY INSTRUCTIONS****Aéreo 03 Portas 1200mm Americana | Aéreo 03 Puertas 1200mm Americana |  
Aerial 03 Doors 1200mm Americana**Referência/Cor  
c C352-05 Branco HPRequisitos para montagem  
Requisitos para la montaje  
Assembly RequirementsImagens meramente ilustrativas  
Imágenes meramente ilustrativas  
Images for illustration only**Pesos máximos recomendados com carga distribuída  
Peso máximo recomendado con la carga distribuida  
Recommended maximum weight with distributed load.****Lista de Peças | Lista de piezas | List of parts**

Item	Caixa Caja Box	Qtd Ctd Qty	Descrição   Descripción   Description	Medidas (mm)   Dimensions (mm)   Size (measurements) (mm)
01	1/1	01	Base   Base   Base	1200x295x15
02	1/1	01	Lateral Esquerda   Lateral Izquierda   Right Left	800x295x15
03	1/1	01	Divisão   División   Division	800x295x15
04	1/1	01	Prateleira Menor   Estante Pequeño   Smaller Shelf	382x295x15
05	1/1	01	Lateral Direita   Lateral Derecha   Right Side	800x295x15
06	1/1	02	Prateleira   Estante   Shelf	772x295x15
07	1/1	01	Tampo   Tapa   Top	1200x322x15
08	1/1	01	Fundo Lateral   Fondo Lateral   Lateral Background	824x401x3
09	1/1	03	Fundo   Fondo   Bottom	791x274x3
10	1/1	03	Porta   Puerta   Door	813x396x15

**AVISO**Para limpeza de seu móvel,  
use uma flanela seca ou  
umedecida, e não utilize  
produtos químicos que  
possam danificar seu  
produto.**SISTEMA DE MONTAGEM**O sistema de montagem  
dos produtos, funciona  
de acordo com a ordem  
crescente dos números  
indicados no desenho.  
Ex: 01, 02, 03, 04... até a  
conclusão da montagem.**ADVERTENCIA**Para limpieza de su móvil,  
use una flanela seca  
o húmeda, y no utilice  
productos químicos que  
puedan dañar su producto.**Ferragens | Herrajes | Hardware**

<b>A</b>  Parafuso 5,0x50mm FLA. Tornillo 5,0x50mm FLA. Screw 5.0x50mm FLA.	<b>B</b>  Parafuso 3,5x40mm CHT. Tornillo 3,5x40mm CHT. Screw 3.5x40mm CHT.	<b>C</b>  Parafuso 3,5x14mm FLA. Tornillo 3,5x14mm FLA. Screw 3.5x14mm FLA.	<b>D</b>  Parafuso M4x20mm CHT. ZB. Tornillo M4x20mm CHT. ZB. Screw M4x20mm CHT. ZB.	<b>E</b>  Cavilha 8x25mm Cinta 8x25mm Dowel 8x25mm	<b>F</b>  Calço Removível Calzado extraíble Removable Shim
<b>G</b>  Dobradilha SlideOn Baixa Amortecedor 35mm Bisagra SlideOn Baja Amortiguador 35mm Low SlideOn Hinge 35mm Shock Absorber	<b>H</b>  Puxador Pontual PZ14 Oval Tirador Pontual PZ14 Oval PZ14 Oval Point Knob	<b>I</b>  Bucha plástica 8mm Bucha de plástico 8mm 8mm plastic bushing	<b>J</b>  Suporte de fixação Soporte de fijación Mounting bracket	<b>K</b>  Proteção para cantoneira Ángulo de protección Protection angle	<b>L</b>  Parafuso União 30mm Tornillo Unión 30mm Union Screw 30mm
<b>M</b>  Giz de correção Tiza de corrección Chalk of correction	<b>N</b>  Sachê de cola Bolsa de pegamento Glue bag	<b>O</b>  Adesivo tapa parafuso 10mm Adhesivo tapón de tornillo 10mm Bolt cover adhesive 10mm	<b>P</b>  Fixador de fundos Fijador de fondos Bottom fixer	<b>Q</b>  Prego 10x10mm Clavo 10x10mm Nail 10x10mm	<b>R</b>  Etiqueta resinada Henn Etiqueta resinada Henn Henn resin label

**SISTEMA DE MONTAJE**El sistema de montaje de  
los productos funciona  
de acuerdo con el orden  
crescente de los números  
indicados en el dibujo. Ej.:  
01, 02, 03, 04... hasta la  
conclusión del montaje.**NOTICE**To clean your furniture, use  
a dry or wet cloth, and do  
not use chemicals that may  
damage your product.O parafuso (L) deve ser usada  
somente quando este módulo for  
acoplado a outro módulo componível  
Henn.**RECOMENDAÇÃO**Para fixar o móvel na parede usar o suporte de fixação (J), o parafuso  
3,5x14mm FLA (C), a Bucha 8mm (I) e o parafuso 5,0x50mm FLA (A).El tornillo (L) se debe utilizar sólo  
cuando el módulo está conectado a  
otro módulo componible Henn.**RECOMENDACIÓN**Para conectar el móvil a la pared con el soporte (J), tornillo 3,5 x14mm  
FLA (C), el casquillo de 8 mm (I) y el 5,0 x50mm tornillo FLA (A).The screw (L) should be used only  
when this module is attached to  
another Henn modular module.**RECOMMENDATION**To fix the furniture to the wall use the fixing bracket (J), the 3.5x14mm  
FLA (C) screw, the 8mm bushing (I) and the 5.0x50mm FLA screw (A).**ASSEMBLY SYSTEM**The products' assembly system  
works according to the  
increasing order of the indicated  
numbers. For example:  
01, 02, 03, 04 ... to the end of  
the assembly.

1º

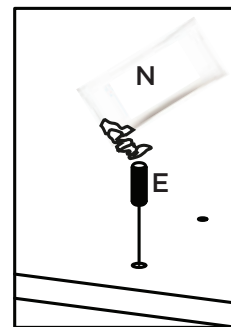
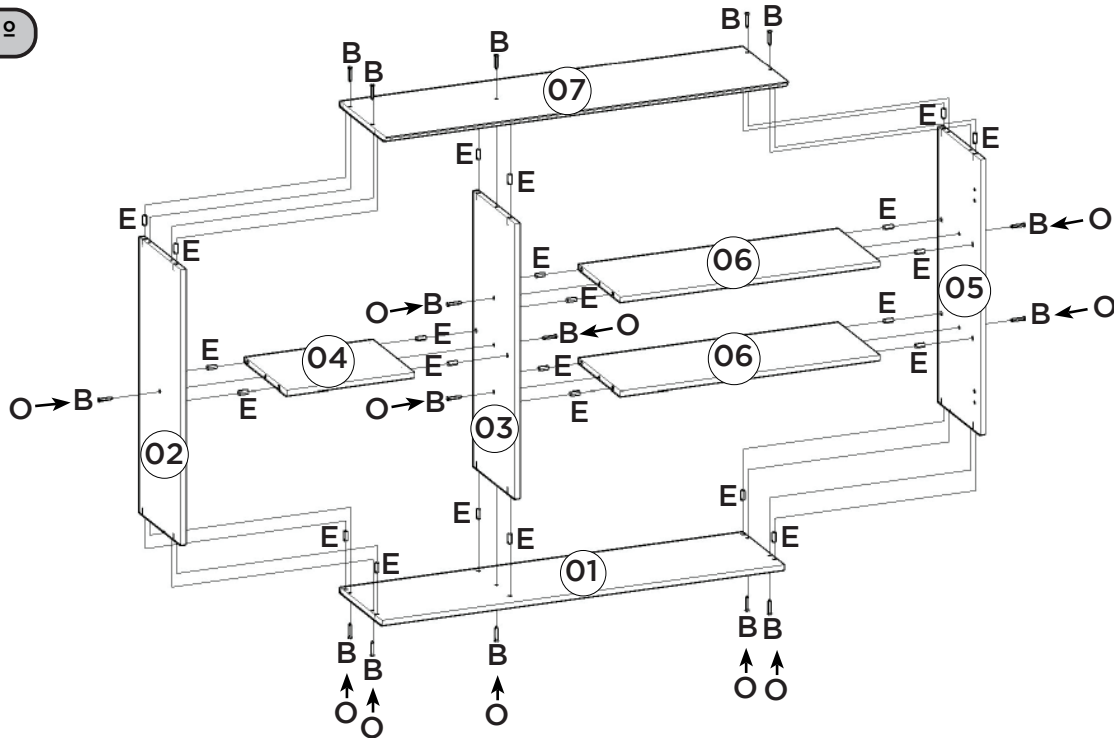

Utilizar o sachê de cola (N) em todas as cavilhas (E) do produto.

Con el pegamento sobre (N) en todos los pernos (E) producto.

Use the glue sachet (N) on all the pegs (E) of the product.

2º

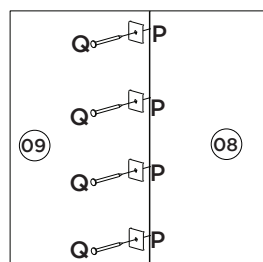
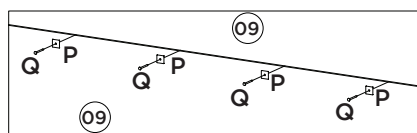
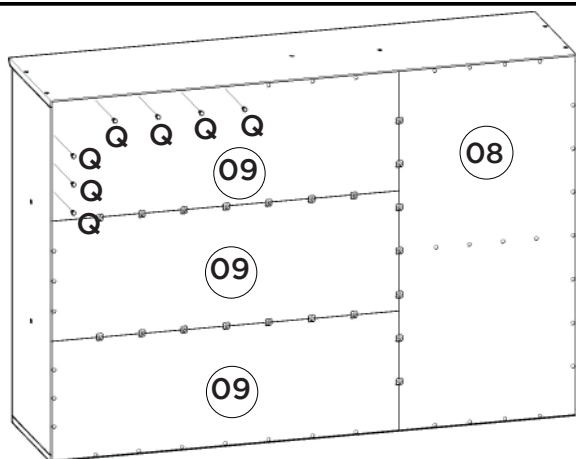

3º

Para saber mais sobre como fixar o móvel de maneira correta, acesse:

Para obtener más información sobre cómo arreglar los muebles correctamente, visite:

To learn more about how to fix the furniture correctly, visit:



<http://bit.ly/guia-de-fixacao-henn>



Imprescindível a fixação do produto na parede.

Es imprescindible la fijación del producto en la pared.

Indispensable to fix the product on the wall.

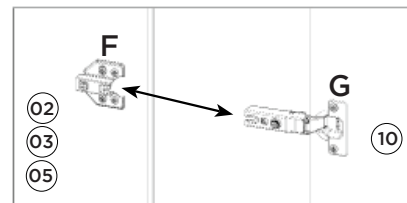
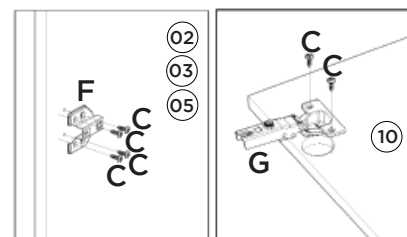
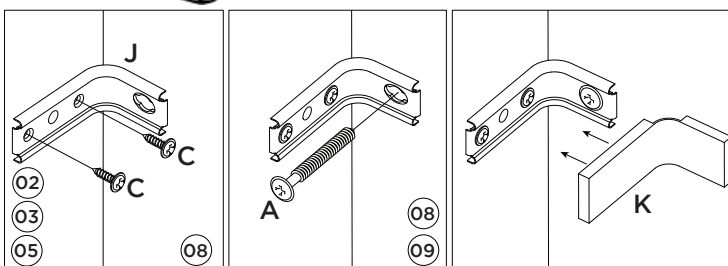

Video: Instalar e regular Dobradiças

Video: Instale y ajuste las bisagras

Video: Install and adjust hinges

Para colocação dos puxadores, é necessário fazer a furação passante, com Broca de 5mm.

Para la colocación de las asas, es necesario perforar a través, con una broca de 5mm.

To place the handles is necessary to make the through hole, drill 5mm.

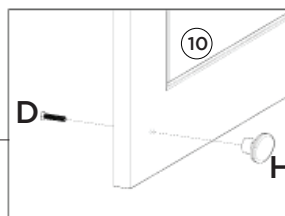
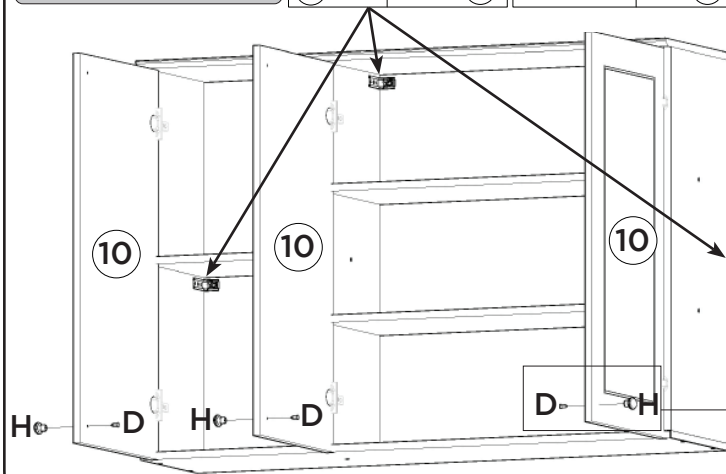

### Torre Quente 2 Fornos Americana | Torre caliente 2 Hornos Americana | 2 Hot Americana Tower furnaces C351-05 Branco HP

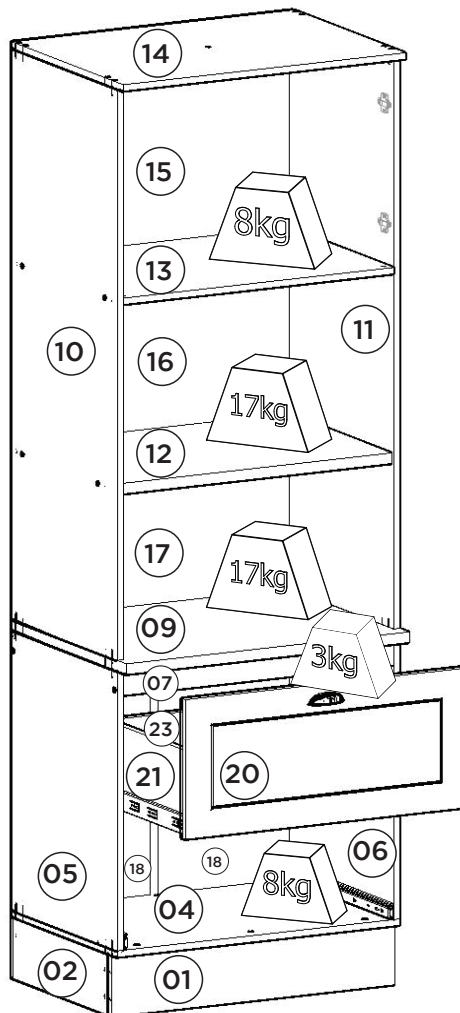
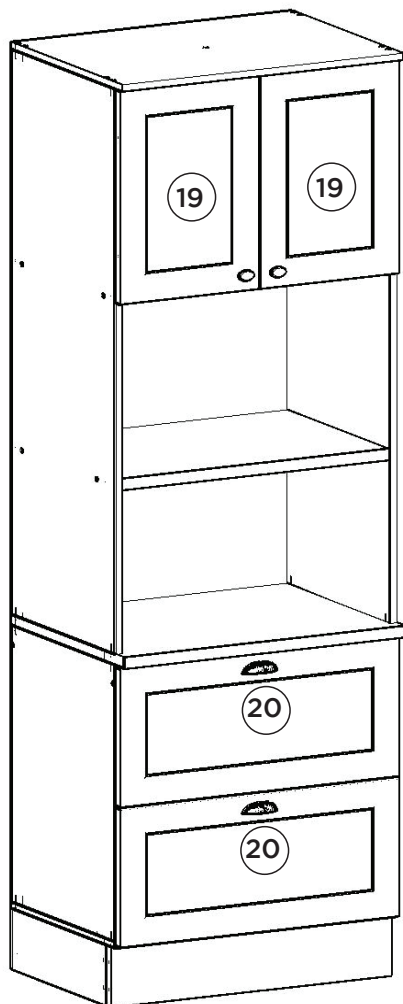

Pesos máximos recomendados com carga distribuída  
Peso máximo recomendado con la carga distribuida  
Recommended maximum weights with evenly distributed.

#### Requisitos para montagem Requisitor para la montaje Assembly Requirements

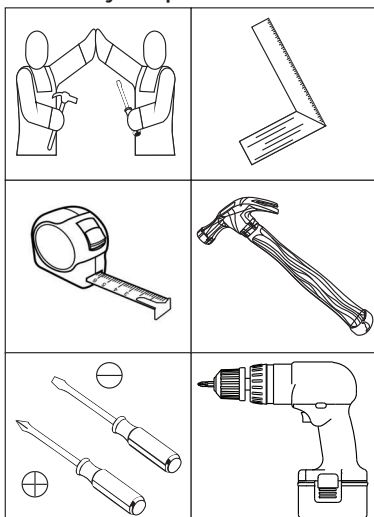

Imagens meramente ilustrativas  
Imágenes meramente ilustrativas  
Images for illustration only

#### AVISO

Para limpeza de seu móvel, use uma flanela seca ou umedecida, e não utilize produtos químicos que possam danificar seu produto.

#### SISTEMA DE MONTAGEM

O sistema de montagem dos produtos, funciona de acordo com a ordem crescente dos números indicados no desenho. Ex: 01, 02, 03, 04... até a conclusão da montagem.

#### ADVERTENCIA

Para limpieza de su móvil, use una flanela seca o húmeda, y no utilice productos químicos que puedan dañar su producto.

#### SISTEMA DE MONTAJE

El sistema de montaje de los productos funciona de acuerdo con el orden creciente de los números indicados en el dibujo. Ej.: 01, 02, 03, 04... hasta la conclusión del montaje.

#### NOTICE

To clean your furniture, use a dry or wet cloth, and do not use chemicals that may damage your product.

#### ASSEMBLY SYSTEM

The products' assembly system works according to the increasing order of the indicated numbers. For example: 01, 02, 03, 04 ... to the end of the assembly.

1º

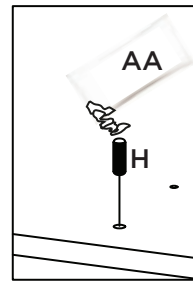
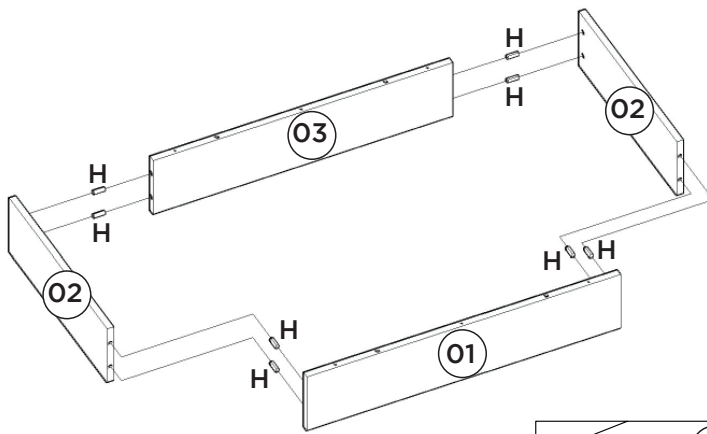

Utilizar o sachê de cola (AA) em todas as cavilhas (H) do produto.

Con el pegamento sobre (AA) en todos los pernos (H) producto.

Use the glue sachet (AA) on all the pegs (H) of the product.

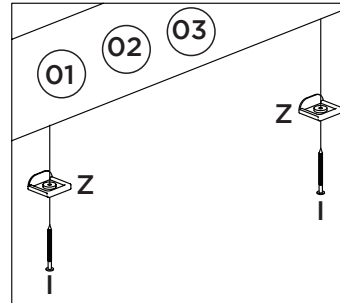
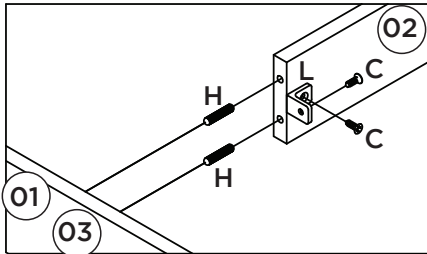

2º

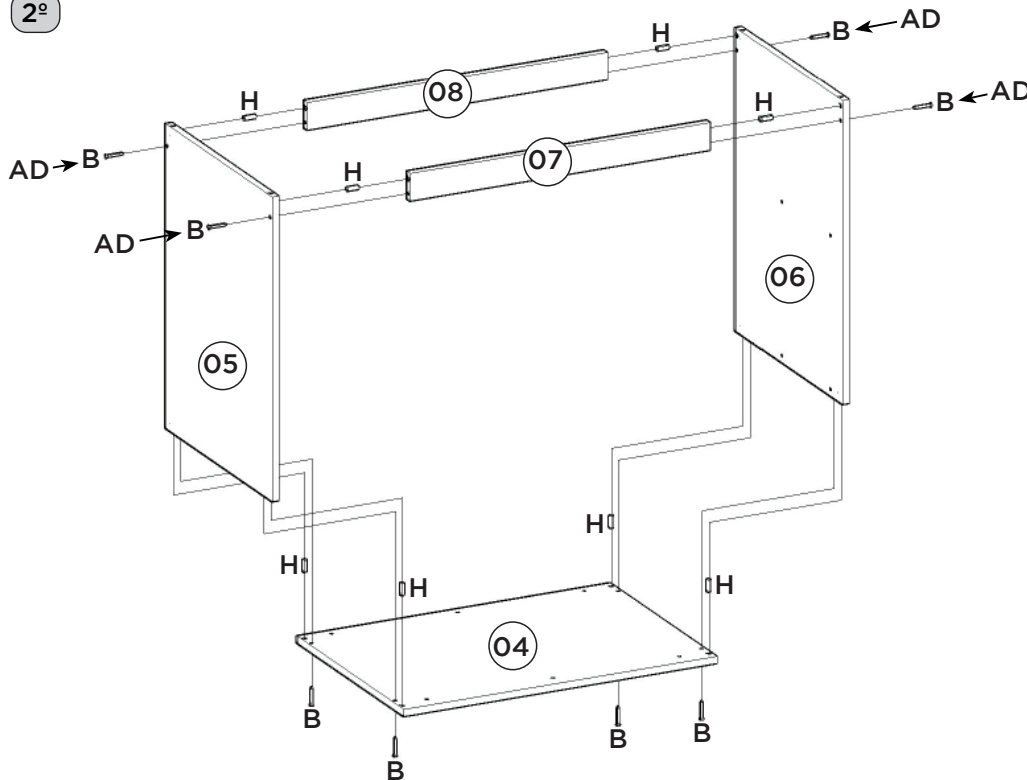
**OPCIONAL:**

O944-121 Kit Pé Cônico 145mm (vendido separadamente). Caso opte em colocar pé no produto, utilizar as pré-furações que possui na Base e fixá-lo com o Parafuso que consta no Kit.

**OPCIONAL:**

O944-121 Kit Pie Cónico 145mm (se vende por separado). Si opta por colocar pie en el producto, utilizar las pre-huracuras que tenga en la Base y fijarlo con el Tornillo que consta en el Kit.

**OPTIONAL:**

O944-121 Tapered Foot Kit 145mm (sold separately). If you choose to put foot in the product, use the pre-drillings in the Base and fix it with the Screw included in the Kit.

3º

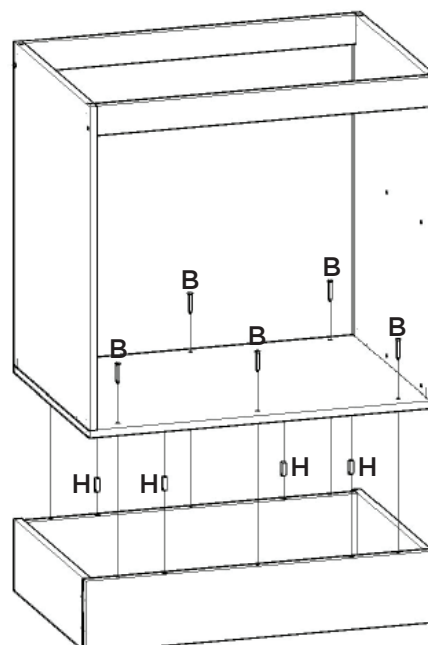

4°

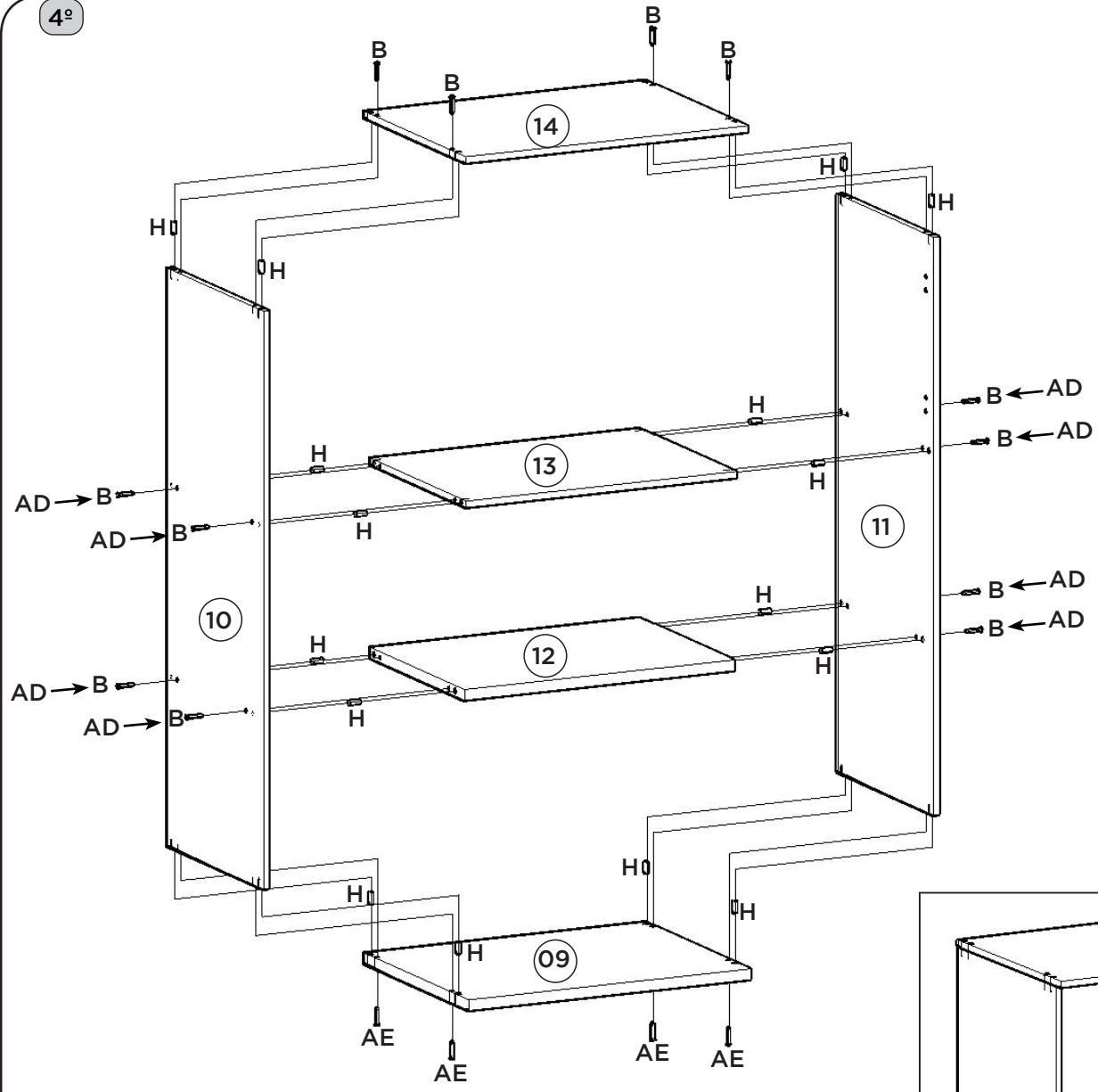

5°

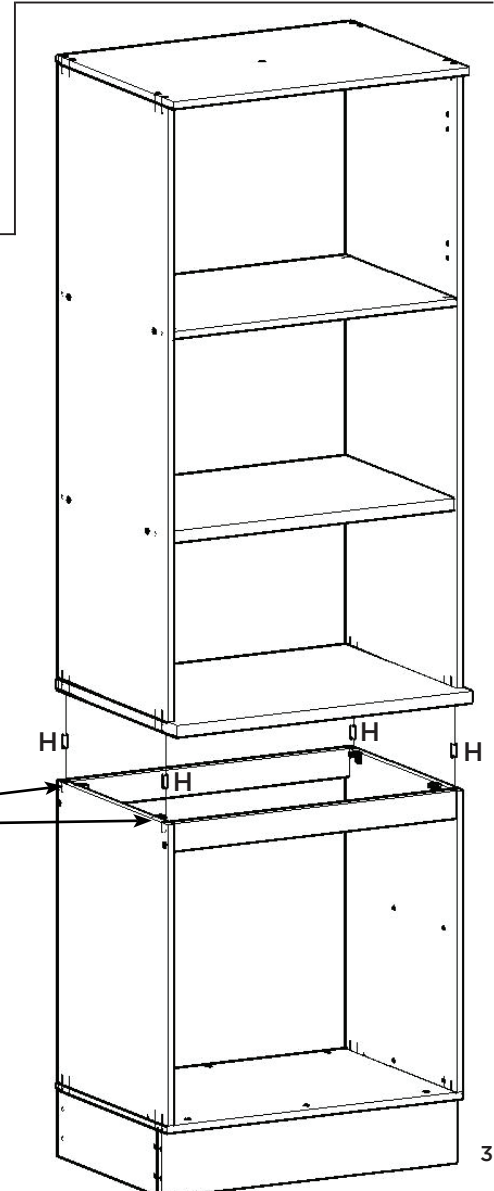
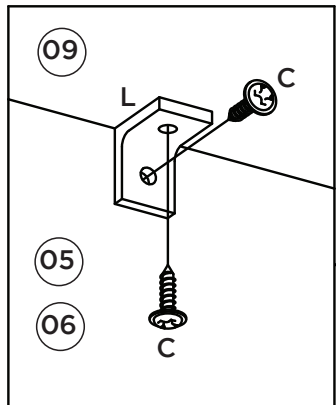



**ATENÇÃO:** Por questão de segurança, recomendamos a não utilização dos Fundos (16 e 17) caso o espaço seja utilizado por forno elétrico ou forno embutido, dessa forma, haverá melhor propagação do calor, evitando danos em seu móvel.

**ATENCIÓN:** Por razones de seguridad, recomendamos la no utilización de los Fondos (16 y 17) en caso de que el espacio sea utilizado por horno eléctrico o horno embutido, de esa forma, habrá mejor propagación del calor, evitando daños en su mueble.

**WARNING:** For safety reasons, we recommend that you do not use the bottoms (16 and 17) if the space is used by an electric oven or built-in oven, in this way, there will be better propagation of the heat, avoiding damage to your furniture.

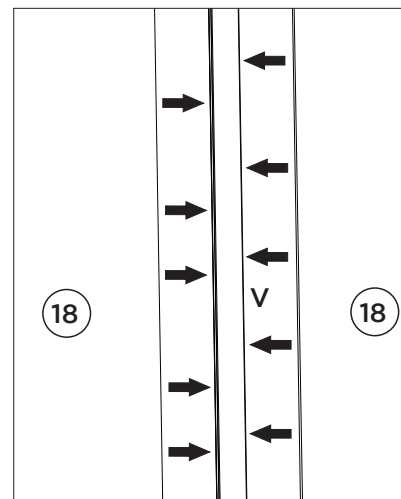
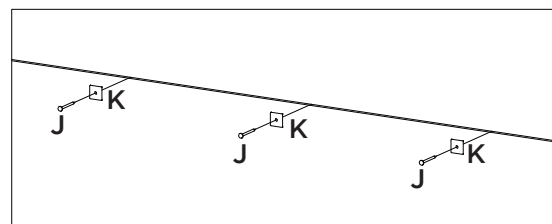
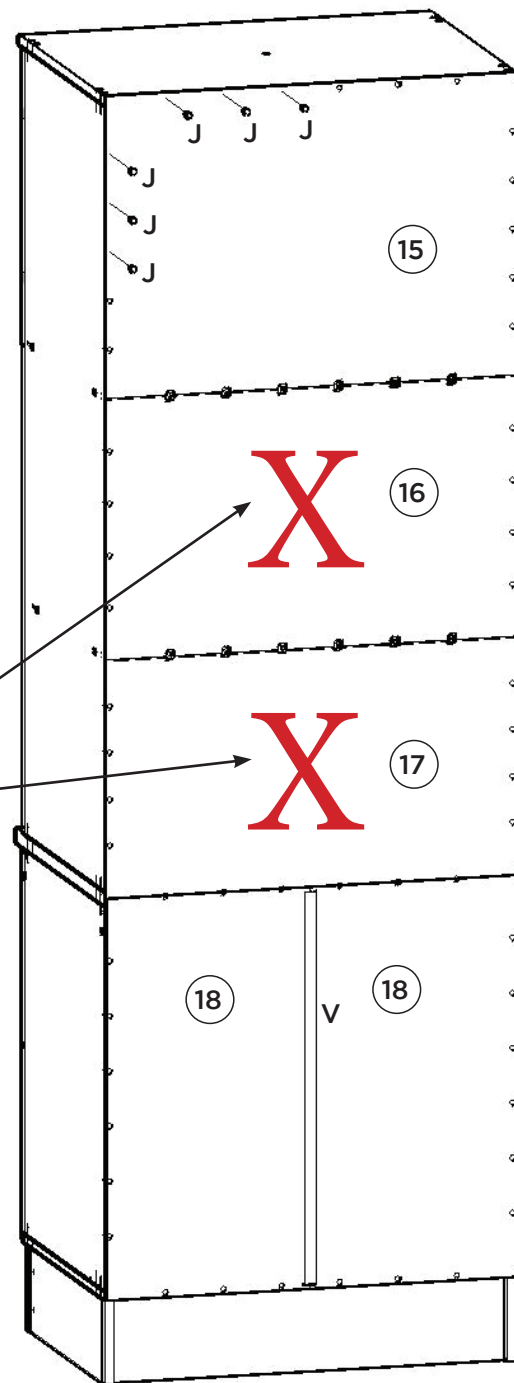

7º

Opção Suspensa

Opción suspendida

Suspended Option



Parede  
pared  
Wall

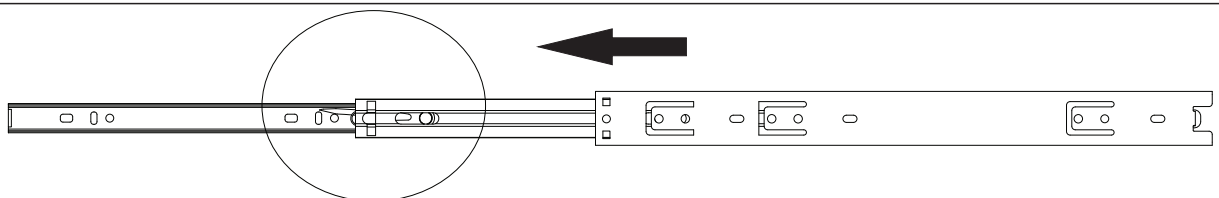
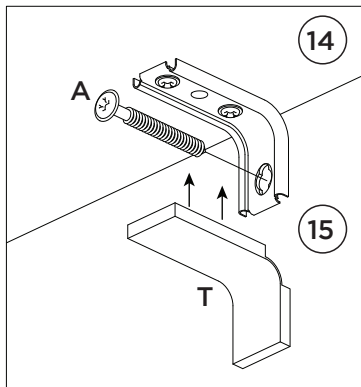
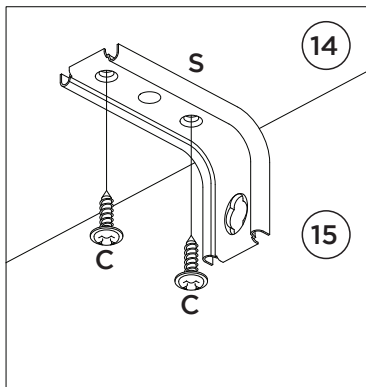
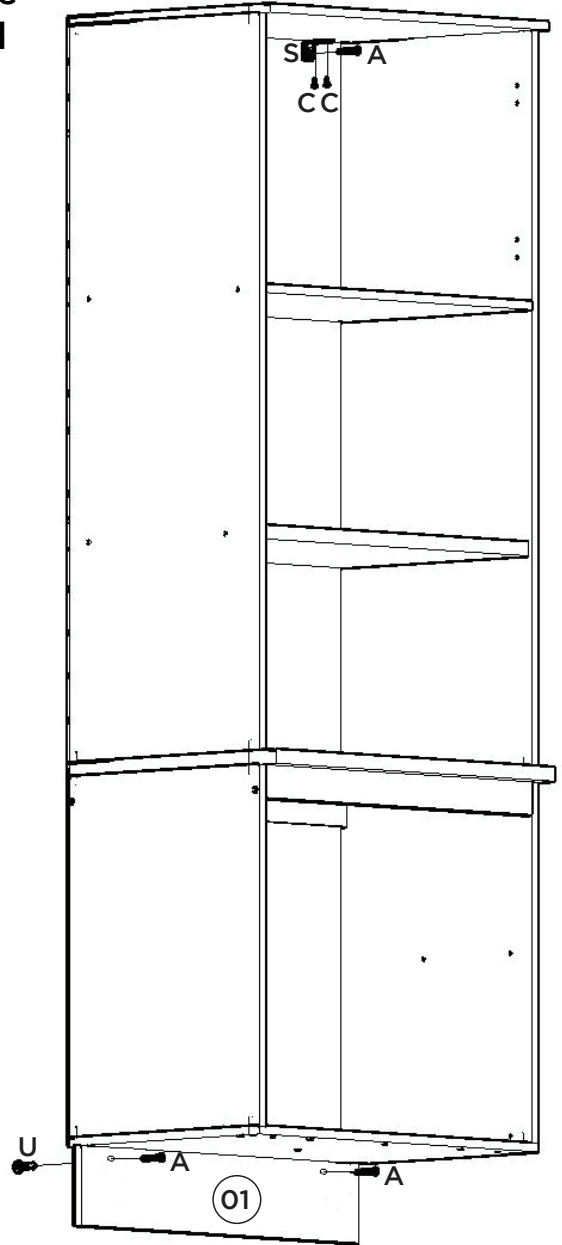

Para a desmontagem da corredeira siga a instrução ao lado.

Para el desmontaje seguimiento de diapositivas la instrucción siguiente a.

For the dismount of the sliding onem follows the instruction aside.

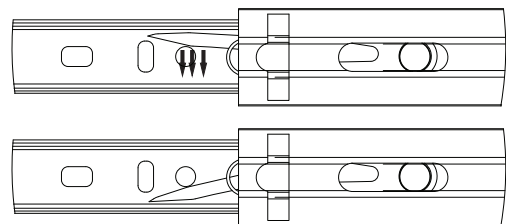

Fixar as corredeiras nessas furações  
Fijar las diapositivas de estos agujeros  
Fix slides in these drillings

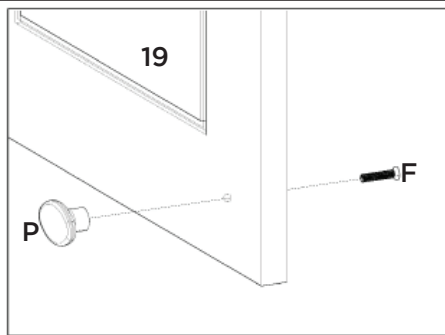

Para colocação dos puxadores, é necessário fazer a furação passante, com Broca de 5mm.

Para la colocación de las asas, es necesario perforar a través, con una broca de 5mm.

To place the handles is necessary to make the through hole, drill 5mm.

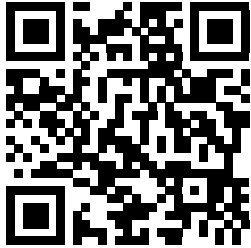

Vídeo: Instalar e regular Dobradiças

Video: Instale y ajuste las bisagras

Video: Install and adjust hinges

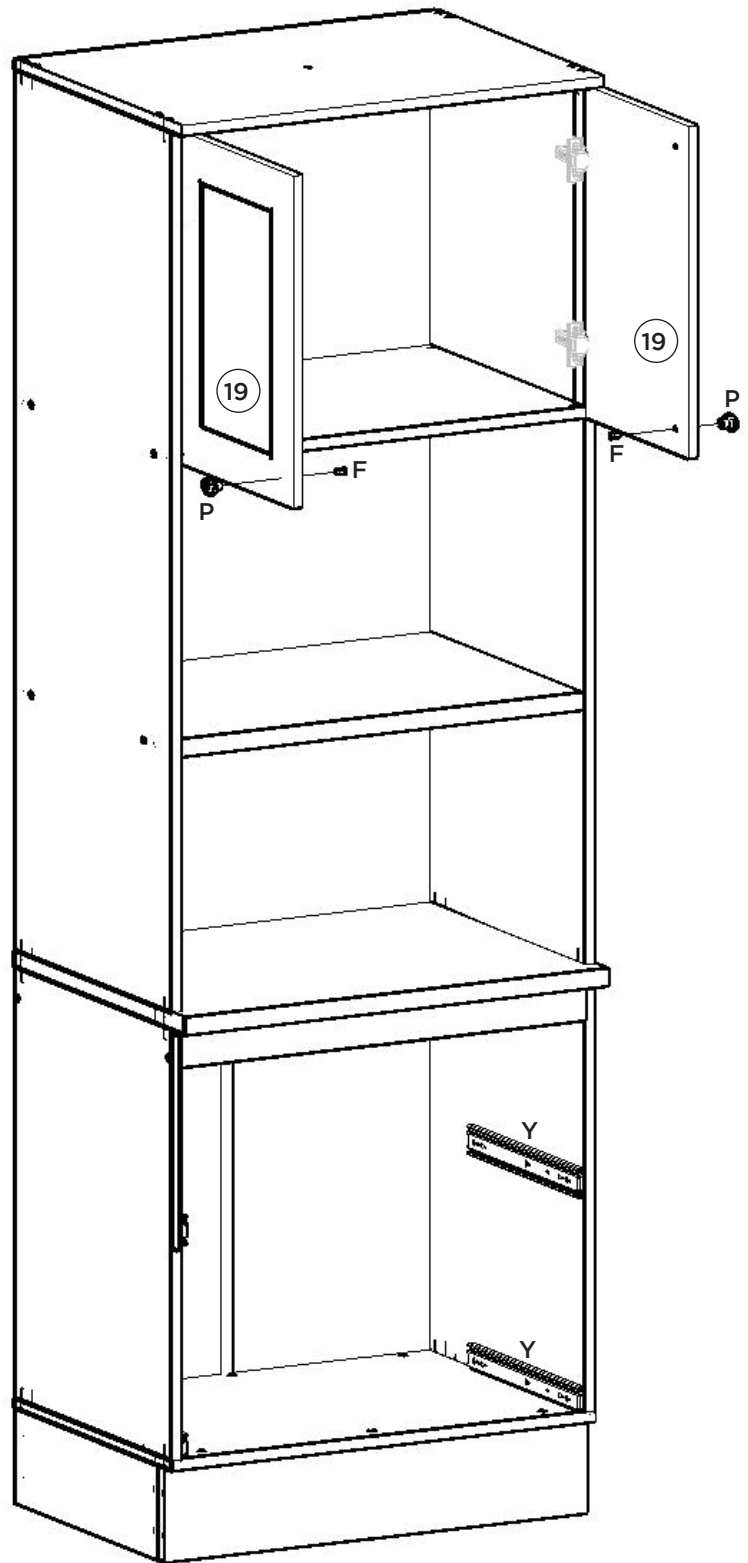
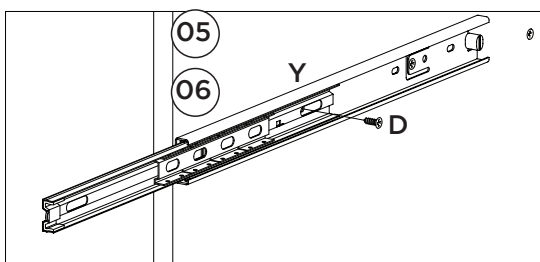
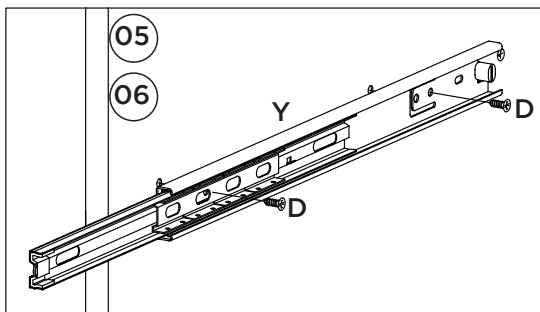
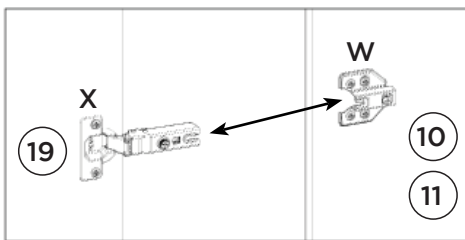
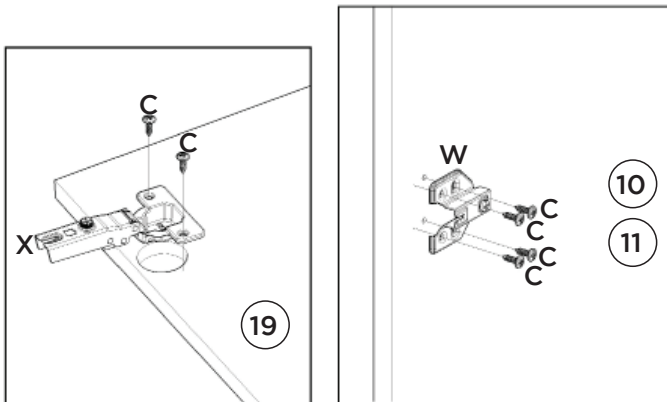

Vídeo: Dicas para fixar a Corrediça

Video: Consejos para arreglar la diapositiva

Video: Tips for Fixing the Slide

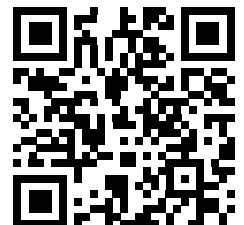



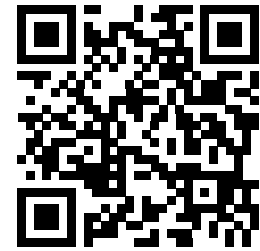
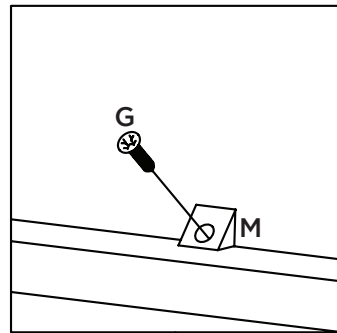
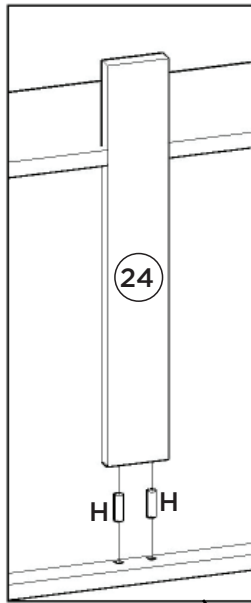
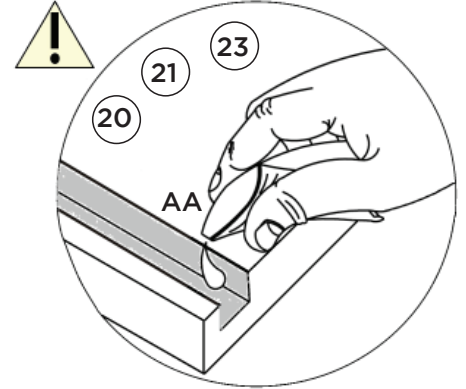
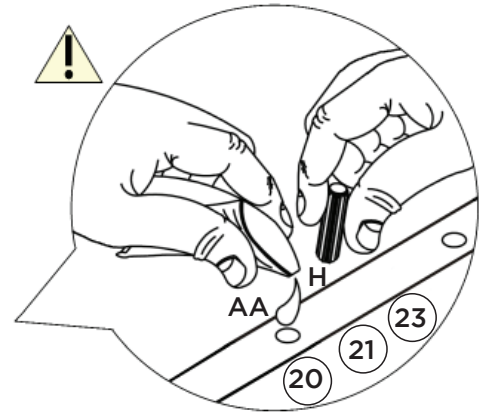
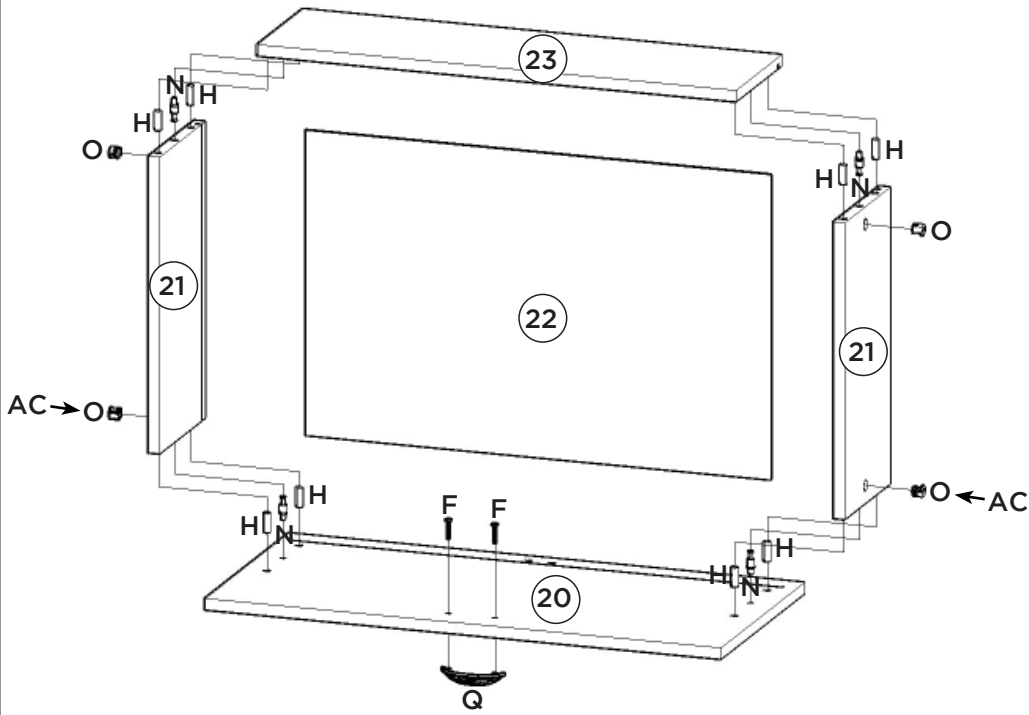

Vídeo: Dicas para fixar o Minifix





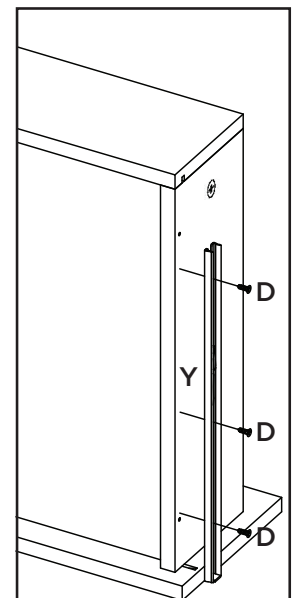
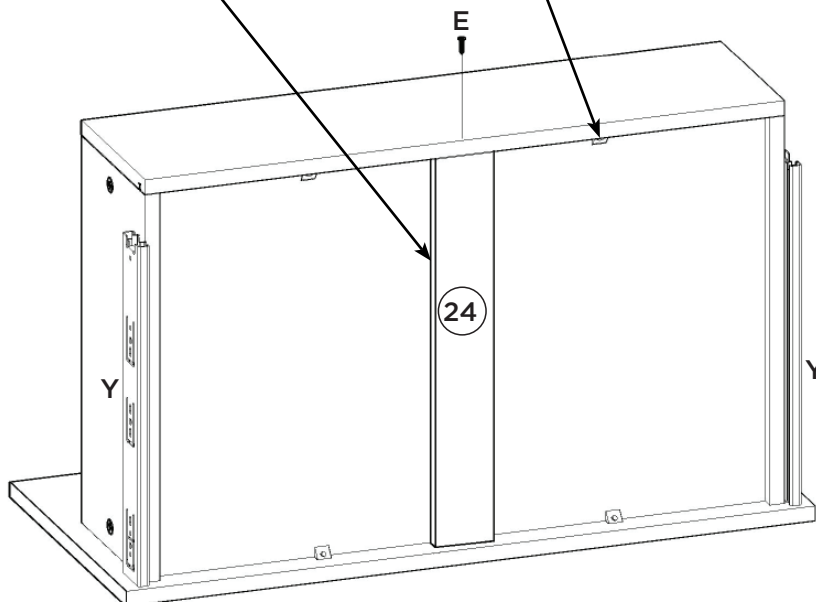





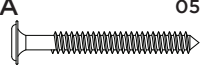

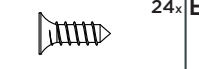

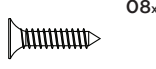
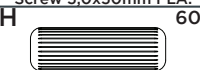
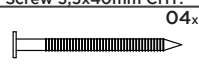
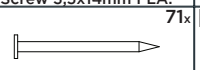
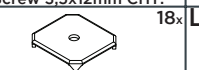

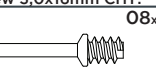

Video: Consejos para arreglar Minifix

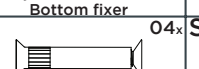
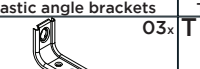
Video: Tips for Fixing Minifix

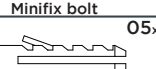
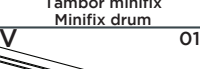

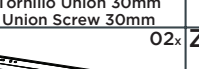
Item	Caixa Caja Box	Qtd Ctd Qty	Descrição   Descripción   Description	Medidas (mm)   Dimensions (mm)   Size (measurements) (mm)
01	1/2	01	Rodapé Frontal   Frente pie de página   Front Footer	715x145x15
02	2/2	02	Rodapé Lateral   Pie de página Side   Side Footer	450x145x15
03	1/2	01	Rodapé Traseiro   Pie de página trasera   Rear Footer	683x145x15
04	2/2	01	Base   Base   Base	715x490x15
05	1/2	01	Lateral Esquerda Inferior   Lateral Izquierda Inferior   Left Side Lower	660x490x15
06	1/2	01	Lateral Direita Inferior   Lateral Derecha Inferior   Right Side Bottom	660x490x15
07	1/2	01	Travessa frontal   Travesaño frontal   Front crossbar	684x60x15
08	1/2	01	Travessa traseira   Travesaño trasero   Rear bumper	684x60x15
09	2/2	01	Tampo 25mm   Tapa 25mm   25mm Top	715x533x25
10	1/2	01	Lateral Esquerda Superior   Lateral Izquierda Superior   Upper Left Side	1345x490x15
11	1/2	01	Lateral Direita Superior   Lateral Derecha Superior   Right Side Superior	1345x490x15
12	2/2	01	Prateleira 25mm   Estantería 25mm   Shelf 25mm	684x480x25
13	2/2	01	Prateleira Central   Estantería central   Central Shelf	684x490x15
14	2/2	01	Tampo   Tapa   Top	715x517x15
15	2/2	01	Fundo Superior   Fondo superior   Superior background	708x272x3
16	2/2	01	Fundo Central Maior   Fondo Central Mayor   Major Central Fund	708x447x3
17	2/2	01	Fundo central   Fondo central   Central fund	708x405x3
18	2/2	02	Fundo Cru   Fondo Crudo   Raw Background	687x353x3
19	1/2	02	Porta Menor   Puerto Menor   Less door	508x354x15
20	1/2	02	Frente de gaveta   Frente de cajón   Front of drawer	711x330x15
21	1/2 e 2/2	04	Lado de Gaveta   Lado del cajón   Drawer Side	400x180x15
22	1/2	02	Fundo de gaveta   Fondo de cajón   Bottom of drawer	640x411x3
23	2/2	02	Ripa de trás   Malla detrás   Rear lath	659x180x15
24	2/2	02	Ripa Estrutural Gaveta   Ripa Estructural Cajón   Drawer Structural Clamp	400x60x15

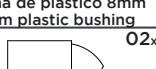
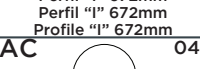
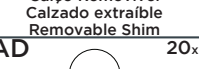
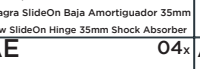
Ferragens | Herrajes | Hardware

<b>A</b> 05x  Parafuso 5,0x50mm FLA. Tornillo 5,0x50mm FLA. Screw 5,0x50mm FLA.	<b>B</b> 26x  Parafuso 3,5x40mm CHT. Tornillo 3,5x40mm CHT. Screw 3,5x40mm CHT.	<b>C</b> 46x  Parafuso 3,5x14mm FLA. Tornillo 3,5x14mm FLA. Screw 3,5x14mm FLA.	<b>D</b> 24x  Parafuso 3,5x12mm CHT. Tornillo 3,5x12mm CHT. Screw 3,5x12mm CHT.	<b>E</b> 02x  Parafuso 3,0x30mm CHT. Tornillo 3,0x30mm CHT. Screw 3,0x30mm CHT.	<b>F</b> 06x  Parafuso M4x20mm CHT. ZB Tornillo M4x20mm CHT. ZB Screw M4x20mm CHT. ZB	<b>G</b> 08x  Parafuso 3,0x16mm CHT. Tornillo 3,0x16mm CHT. Screw 3,0x16mm CHT.
<b>H</b> 60x  Cavilha 8x25mm Cinta 8x25mm Dowel 8x25mm	<b>I</b> 04x  Prego 12x12mm Anelado Clavo 12x12mm Anillado Ringed Nails 12x12mm	<b>J</b> 71x  Prego 10x10mm Clavo 10x10mm Nail 10x10mm	<b>K</b> 18x  Fixador de fundos Fijador de fondos Bottom fixer	<b>L</b> 08x  Cantoneira plástica Cantonera plástica Plastic angle brackets	<b>M</b> 08x  Cantoneira suporte triangular Cantonera soporte triangular Triangle support angle	<b>N</b> 08x  Parafuso minifix Tornillo minifix Minifix bolt
<b>O</b> 08x  Tambor minifix Tambor minifix Minifix drum	<b>P</b> 02x  Puxador Pontual PZ14 Oval Tirador Pontual PZ14 Oval PZ14 Oval Point Knob	<b>Q</b> 02x  Puxador Concha Tirador Concha Shell Handle	<b>R</b> 04x  Parafuso União 30mm Tornillo Unión 30mm Union Screw 30mm	<b>S</b> 03x  Suporte de fixação Soporte de fijación Mounting bracket	<b>T</b> 03x  Proteção para cantoneira Ángulo de protección Protection angle	<b>U</b> 05x  Buchta plástica 8mm Bucha de plástico 8mm 8mm plastic bushing
<b>V</b> 01x  Perfil "I" 672mm Perfil "I" 672mm Profile "I" 672mm	<b>W</b> 04x  Calço Removível Calzado extraíble Removable Shim	<b>X</b> 04x  Dobradica SlideOn Baixa Amortecedor 35mm Bisagra SlideOn Baja Amortiguador 35mm Low SlideOn Hinge 35mm Shock Absorber	<b>Y</b> 02x  Corrediza telescópica Diapositivas telescópicas Telescopic slides	<b>Z</b> 04x  Sapata "L" 16x20mm Zapata "L" 16x20mm "L" shoe 16x20mm	<b>AA</b> 01x  Sachê de cola Bolsa de pegamento Glue bag	<b>AB</b> 02x  Giz de correção Tiza de corrección Chalk of correction
<b>AC</b> 04x  Adesivo tampa parafuso 17mm Adhesivo tapón de tornillo 17mm Bolt cover adhesive 17mm	<b>AD</b> 20x  Adesivo tampa parafuso 10mm Adhesivo tapón de tornillo 10mm Bolt cover adhesive 10mm	<b>AE</b> 04x  Parafuso 4,5x50mm CHT. Tornillo 4,5x50mm CHT. Screw 4,5x50mm CHT.	<b>AF</b> 01x  Etiqueta resinada Henn Etiqueta resinada Henn Henn resin label			



O parafuso (R) deve ser usada somente quando este módulo for acoplado a outro módulo componível Henn.



El tornillo (R) se debe utilizar sólo cuando el módulo está conectado a otro módulo componible Henn.



The screw (R) should be used only when this module is attached to another Henn modular element.

RECOMENDAÇÃO

Para fixar o móvel na parede usar o suporte de fixação (S), o parafuso 3,5x14mm FLA (C), a Bucha 8mm (U) e o parafuso 5,0x50mm FLA (A).

RECOMENDACIÓN

Para conectar el móvil a la pared con el soporte (S), tornillo 3,5 x14mm FLA (C), el casquillo de 8 mm (U) y el 5,0 x50mm tornillo FLA (A).

RECOMMENDATION

To fix the furniture to the wall use the mounting bracket (S), the 3.5x14mm FLA (C) screw, the 8mm bushing (U) and the 5.0x50mm FLA (A).

**HENN**Ind. e Com. de Móveis Henn  
Mondai - SC - Brasil

☎+55 49 3674.3500

📧@moveishenn  
www.henn.com.br**INSTRUÇÕES DE MONTAGEM**INSTRUCCIONES DE MONTAJE  
ASSEMBLY INSTRUCTIONS**BALCÃO 2 PORTAS 800MM AMERICANA | BALCÓN 2 PUERTAS 800MM AMERICANA |  
BALCONY 2 DOORS 800MM AMERICANA****Referência/Cor**

☐ C355-05 Branco HP

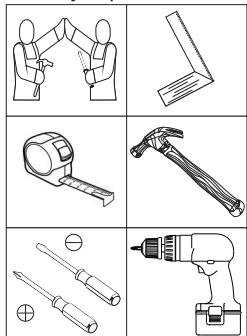
Requisitos para montagem  
Requisitor para la montaje  
Assembly RequirementsImagens meramente ilustrativas  
Imágenes meramente ilustrativas  
Images for illustration only**OPCIONAL:**

O944-121 Kit Pé Cônico 145mm (vendido separadamente). Caso opte em colocar pé no produto, utilizar as pré-furações que possui na Base e fixá-lo com o Parafuso que consta no Kit.

**OPCIONAL:**

O944-121 Kit Pie Cónico 145mm (se vende por separado). Si opta por colocar pie en el producto, utilizar las pre-huracuras que tenga en la Base y fijarlo con el Tornillo que consta en el Kit.

**OPTIONAL:**

O944-121 Tapered Foot Kit 145mm (sold separately). If you choose to put foot in the product, use the pre-drillings in the Base and fix it with the Screw included in the Kit.

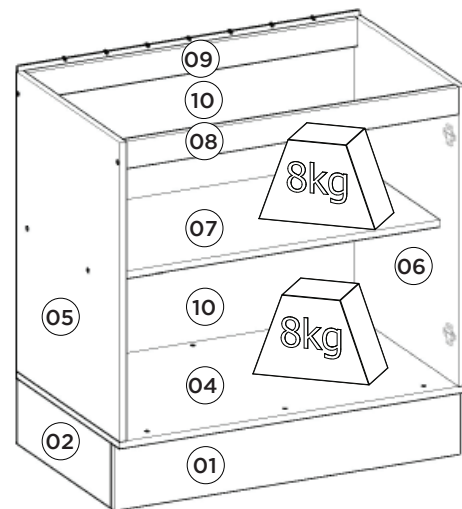
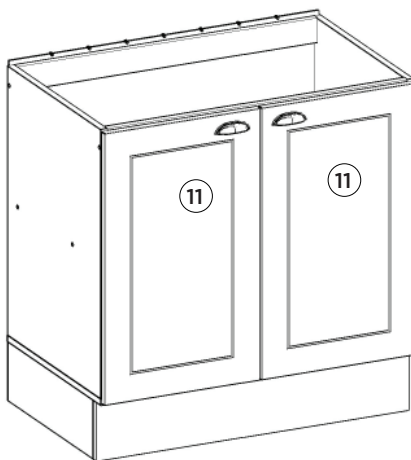
Pesos máximos recomendados com carga distribuída  
Peso máximo recomendado con la carga distribuída  
Recommended maximum weights with evenly distributed.**AVISO**

Para limpeza de seu móvel, use uma flanela seca ou umedecida, e não utilize produtos químicos que possam danificar seu produto.

**SISTEMA DE MONTAGEM**

O sistema de montagem dos produtos, funciona de acordo com a ordem crescente dos números indicados no desenho. Ex: 01, 02, 03, 04... até a conclusão da montagem.

**ADVERTENCIA**

Para limpieza de su móvil, use una flanela seca o húmeda, y no utilice productos químicos que puedan dañar su producto.

**SISTEMA DE MONTAJE**

El sistema de montaje de los productos funciona de acuerdo con el orden creciente de los números indicados en el dibujo. Ej.: 01, 02, 03, 04... hasta la conclusión del montaje.

**NOTICE**

To clean your furniture, use a dry or wet cloth, and do not use chemicals that may damage your product.











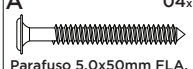
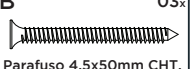
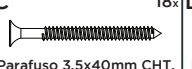

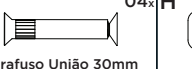
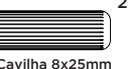
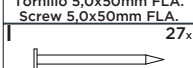
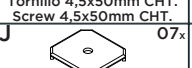

**ASSEMBLY SYSTEM**

The products' assembly system works according to the increasing order of the indicated numbers. For example: 01, 02, 03, 04 ... to the end of the assembly.

**Lista de Peças | Lista de piezas | List of parts**

Item	Caixa Caja Box	Qtd Ctd Qty	Descrição   Descripción   Description	Medidas (mm)   Dimensions (mm)   Size (measurements) (mm)
01	1/1	01	Rodapé Frontal   Frente pie de página   Front Footer	800x145x15
02	1/1	02	Rodapé Lateral   Pie de página Side   Side Footer	450x145x15
03	1/1	01	Rodapé Traseiro   Pie de página trasera   Rear Footer	768x145x15
04	1/1	01	Base   Base   Base	800x490x15
05	1/1	01	Lateral esquerda   Lateral izquierda   Left side	660x490x15
06	1/1	01	Lateral direita   Lateral derecha   Right side	660x490x15
07	1/1	01	Prateleira   Estante   Shelf	769x400x15
08	1/1	01	Travessa frontal   Travesaño frontal   Front crossbar	769x60x15
09	1/1	01	Travessa traseira   Travesaño trasero   Rear bumper	769x60x15
10	1/1	02	Fundo   Fondo   Bottom	792x341x3
11	1/1	02	Porta   Puerta   Door	665x396x15

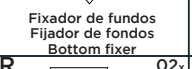
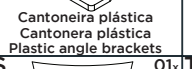
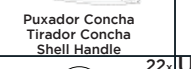
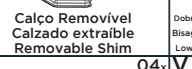
**Ferragens | Herrajes | Hardware**

<b>A</b> 04x  Parafuso 5,0x50mm FLA. Tornillo 5,0x50mm FLA. Screw 5,0x50mm FLA.	<b>B</b> 03x  Parafuso 4,5x50mm CHT. Tornillo 4,5x50mm CHT. Screw 4,5x50mm CHT.	<b>C</b> 18x  Parafuso 3,5x40mm CHT. Tornillo 3,5x40mm CHT. Screw 3,5x40mm CHT.	<b>D</b> 44x  Parafuso 3,5x14mm FLA. Tornillo 3,5x14mm FLA. Screw 3,5x14mm FLA.	<b>E</b> 07x  Parafuso 3,5x12mm CHT. Tornillo 3,5x12mm CHT. Screw 3,5x12mm CHT.	<b>F</b> 04x  Parafuso M4x20mm CHT. ZB Tornillo M4x20mm CHT. ZB Screw M4x20mm CHT. ZB	<b>G</b> 04x  Parafuso União 30mm Tornillo Unión 30mm Union Screw 30mm	<b>H</b> 24x  Cavilha 8x25mm Cinta 8x25mm Dowel 8x25mm
<b>I</b> 27x  Prego 10x10mm Clavo 10x10mm Nail 10x10mm	<b>J</b> 07x  Fixador de fundos Fijador de fondos Bottom fixer	<b>K</b> 08x  Cantoneira plástica Cantenera plástica Plastic angle brackets	<b>L</b> 02x  Puxador Concha Tirador Concha Shell Handle	<b>M</b> 04x  Calço Removível Calzado extraíble Removable Shim	<b>N</b> 04x  Dobradora SlideOn Baja Amortecedor 35mm Bisagra SlideOn Baja Amortiguador 35mm Low SlideOn Hinge 35mm Shock Absorber	<b>O</b> 04x  Buchta plástica 8mm Buchta de plástico 8mm 8mm plastic bushing	<b>P</b> 02x  Suporte de fixação Soporte de fijación Mounting bracket
<b>Q</b> 02x  Proteção para cantoneira Ángulo de protección Protection angle	<b>R</b> 02x  Giz de correção Tiza de corrección Chalk of correction	<b>S</b> 01x  Sachê de cola Bolsa de pegamento Glue bag	<b>T</b> 22x  Adesivo tapa parafuso 10mm Adhesivo tapón de tornillo 10mm Bolt cover adhesive 10mm	<b>U</b> 04x  Prego 12x12mm Anelado Clavo 12x12mm Anillado Ringed Nails 12x12mm	<b>V</b> 04x  Sapata "L" 16x20mm Zapata "L" 16x20mm "L" shoe 16x20mm		



O parafuso (G) deve ser usada somente quando este módulo for acoplado a outro módulo componível Henn.



El tornillo (G) se debe utilizar sólo cuando el módulo está conectado a otro módulo componible Henn.



The screw (G) should be used only when this module is attached to another Henn modular module.

**RECOMENDAÇÃO**

Para fixar o móvel na parede usar o suporte de fixação (P), o parafuso 3,5x14mm FLA (D), a Bucha 8mm (O) e o parafuso 5,0x50mm FLA (A).

**RECOMENDACIÓN**

Para conectar el móvil a la pared con el soporte (P), tornillo 3,5 x14mm FLA (D), el casquillo de 8 mm (O) y el 5,0 x50mm tornillo FLA (A).

**RECOMMENDATION**

To fix the furniture to the wall use the mounting bracket (P), the 3.5x14mm FLA (D) screw, the 8mm bushing (O) and the 5.0x50mm FLA (A).

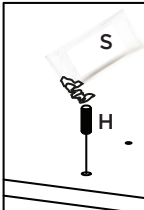
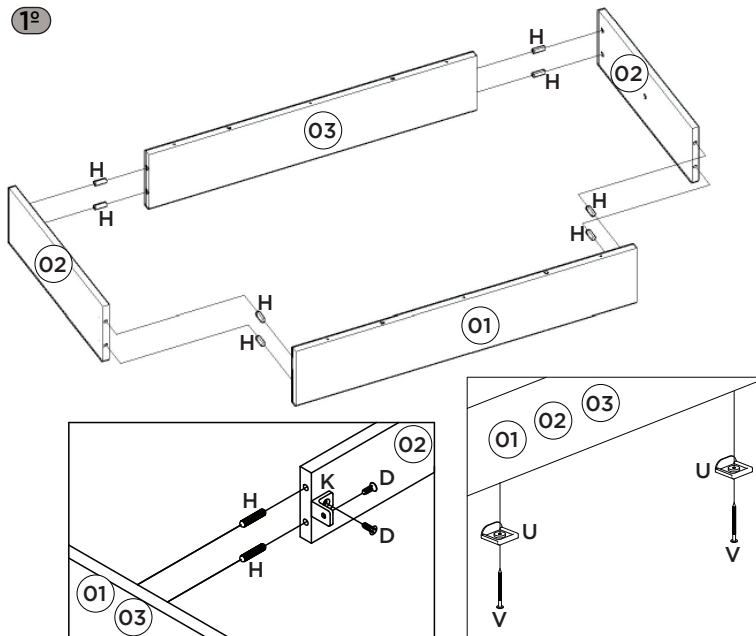

Utilizar o sachê de cola (S) em todas as cavilhas (H) do produto.  
 Con el pegamento sobre (S) en todos los pernos (H) producto.  
 Use the glue sachet (S) on all the pegs (H) of the product.

2º Esse tampo é opcional e é vendido separadamente (C904-114).  
 Esta vez es opcional y se vende por separado (C904-114).  
 This top is optional and is sold separately (C904-114).

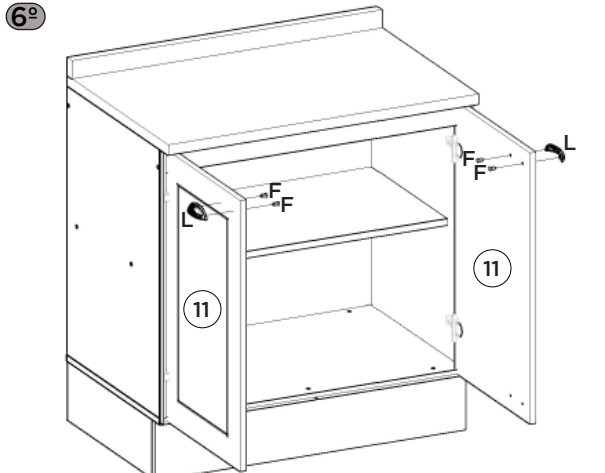
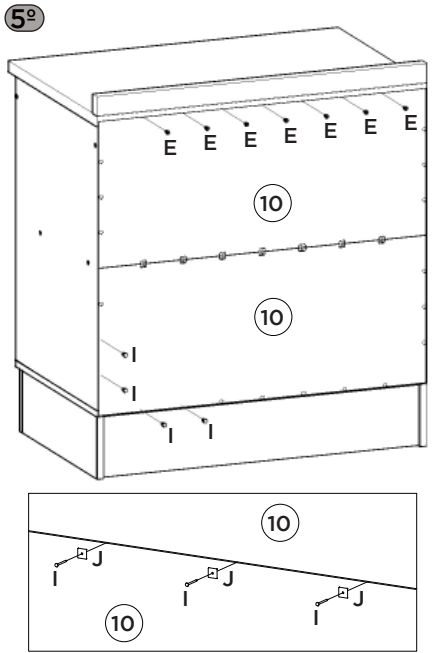
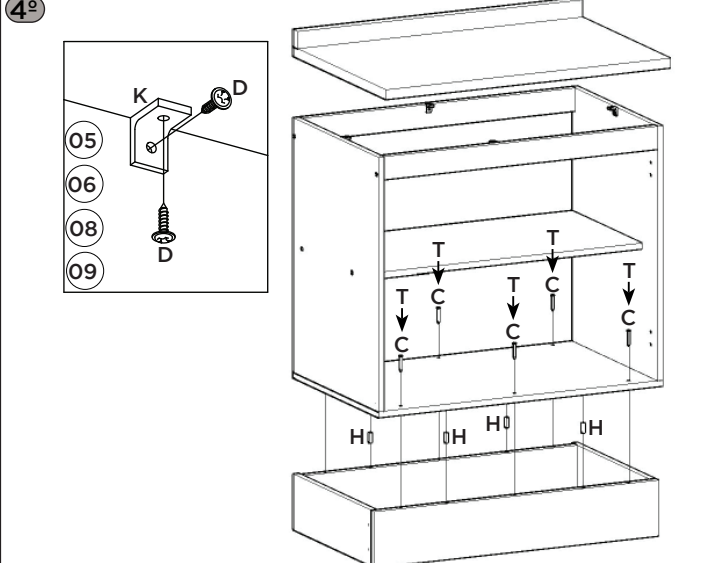
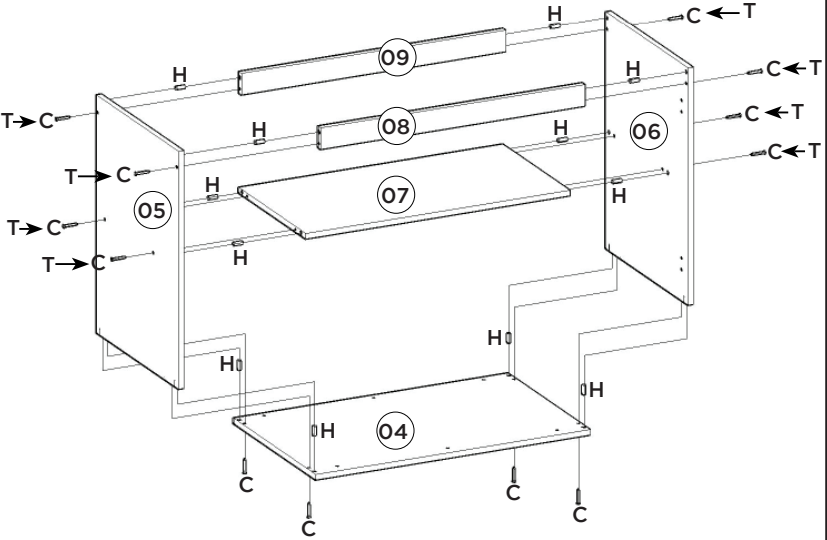
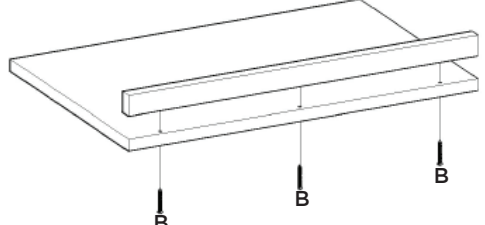

Para colocação dos puxadores, é necessário fazer a furação passante, com Broca de 5mm.  
 Para la colocación de las asas, es necesario perforar a través, con una broca de 5mm.  
 To place the handles is necessary to make the through hole, drill 5mm.

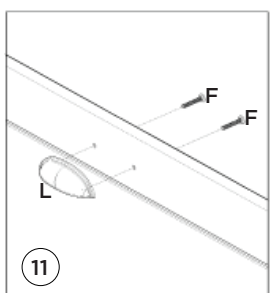

Opção Suspensa  
 Opción suspendida  
 Suspended Option

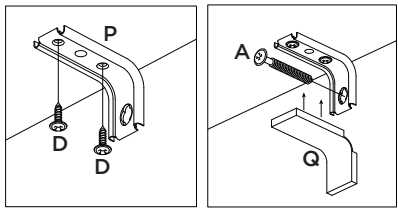

Video: Instalar e regular Dobradiças  
 Video: Instale y ajuste las bisagras  
 Video: Install and adjust hinges

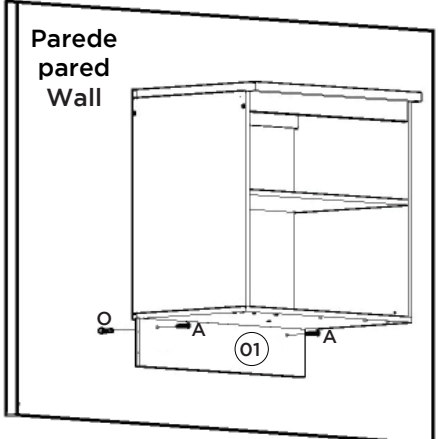
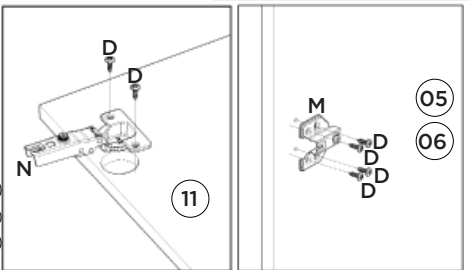

Parede pared Wall