

kappesberg

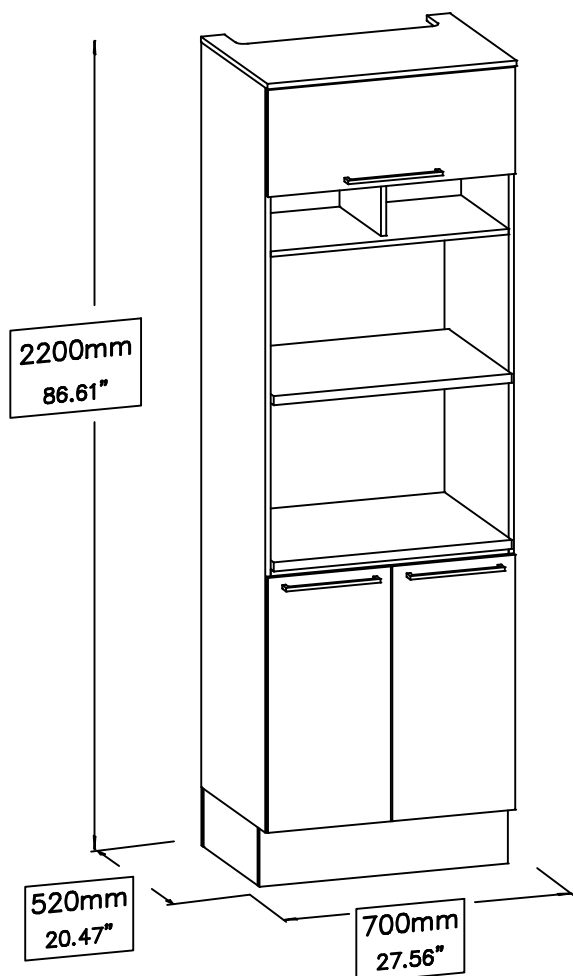

A montagem deve ser efetuada por UMA pessoa.
El montaje debe ser efectuado por UNA persona.
The assembly must be done by ONE people.

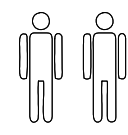

Ferramentas necessárias para montar o móvel
Herramientas necesarias para armar el mueble.
Tools needed to assemble the furniture.

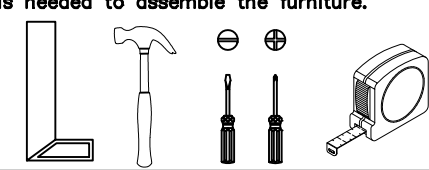

Montar o móvel sobre uma superfície limpa e plana
Armar el mueble sobre una superficie limpia y plana
Assemble the furniture on a clean and flat surface

Y:\Pastas pessoais\Rudimar\Capturar 2.PNG

Lista de peças / Lista de piezas / List of pieces

Código / Code	Descrição	Descripción	Description	Quantidade / Cantidad / Amount	Comprimento / Longitud / Length (mm)	Comprimento / Longitud / Length (in.)	Largura / Ancho / Width (mm)	Largura / Ancho / Width (in.)	Espessura / Espesor / Thickness (mm)	Espessura / Espesor / Thickness (in.)	Caixa / Caja / Box
01	Lateral direita	Parte derecha	Right side	1	2040	80.31"	496	19.53"	15	.59"	A
02	Lateral esquerda	Parte izquierda	Left side	1	2040	80.31"	496	19.53"	15	.59"	A
03	Base	Pieza de suelo	Base	1	670	26.38"	496	19.53"	15	.59"	B
04	Prateleira	Estante	Shelf	1	670	26.38"	430	16.93"	15	.59"	A
05	Base do nicho	Pieza de suelo de nicho	Niche base	1	670	26.38"	384	15.12"	15	.59"	B
06	Base do aéreo	Pieza de techo de nicho	Ceiling piece of the niche	1	670	26.38"	367	14.45"	15	.59"	B
07	Chapéu	Pieza de techo	Top	1	701	27.60"	514	20.24"	15	.59"	B
08	Divisória superior	División superior	Upper partition	1	320	12.60"	150	5.91"	15	.59"	A
09	Porta basculante	Puerta abatible	Flap door	1	696	27.40"	293	11.54"	15	.59"	A
10	Costas superior	Pieza superior del fondo	Top part of the bottom	1	670	26.38"	449	17.68"	15	.59"	A
11	Travessa	Travesaño	Crosspiece	1	670	26.38"	70	2.76"	15	.59"	A
12	Rodapé lateral	Falda lateral	Side Skirting	2	420	16.54"	160	6.30"	15	.59"	A
13	Rodapé	Zócalo	Baseboard	2	699	27.52"	160	6.30"	15	.59"	A
14	Tampo inferior	Panel inferior	Bottom panel	1	670	26.38"	520	20.47"	25	.98"	A
15	Tampo superior	Panel superior	Top bottom panel	1	670	26.38"	488	19.21"	25	.98"	A
16	Costas	Pieza del fondo	Back panel	2	690	27.17"	361	14.21"	3	.12"	A
17	Porta inferior	Puerta inferior	Bottom door	2	698	27.48"	346	13.62"	15	.59"	B

IDENTIFICAÇÃO DAS PEÇAS/ IDENTIFICACIÓN DE LAS PIEZAS/ PARTS IDENTIFICATION

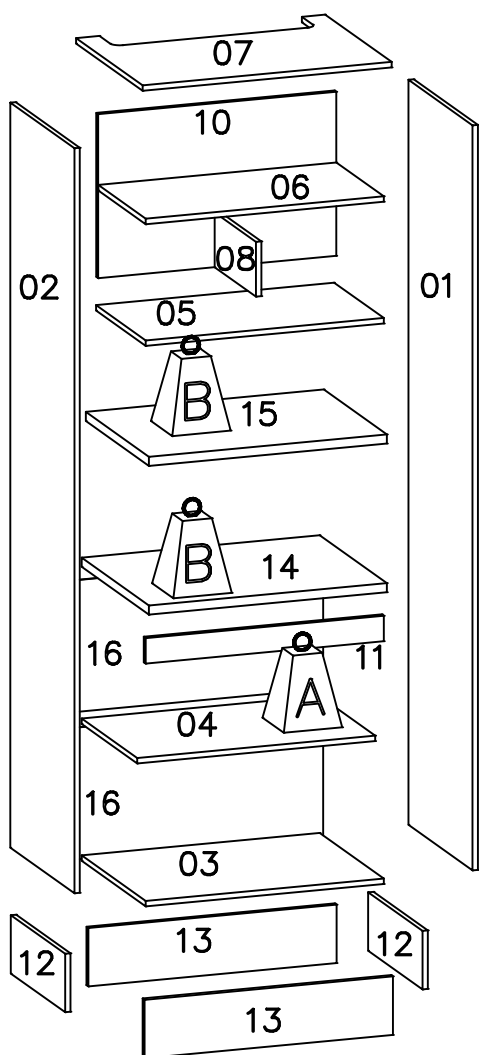
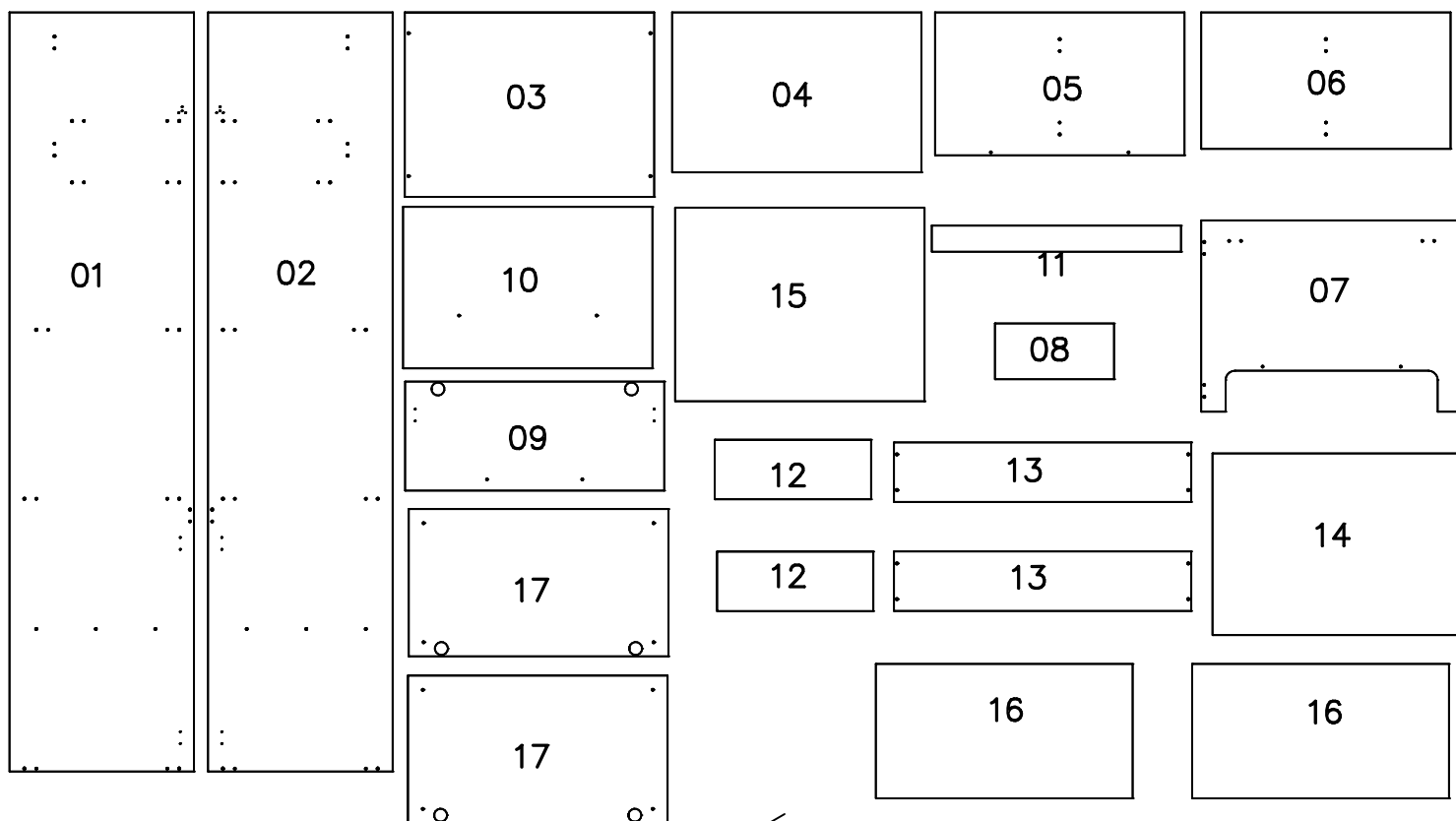

Duvidas? entrar em contato:
¿Dudas? Ponerse en contacto:
Doubts? Get in touch:

Fone: (51) 3635-8839
www.kappesberg.com.br

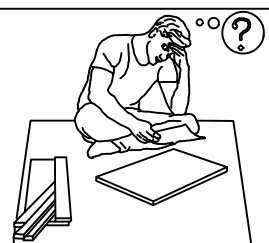

	Kg	lb
A	7	15.43lb
B	20	44.09lb

Em caso de dúvida,
compare as ferragens com
as imagens no decorrer do
manual.

En caso de duda,
compare el hardware
con las imágenes del
manual.

If in doubt, compare the
hardware with the images
throughout the manual

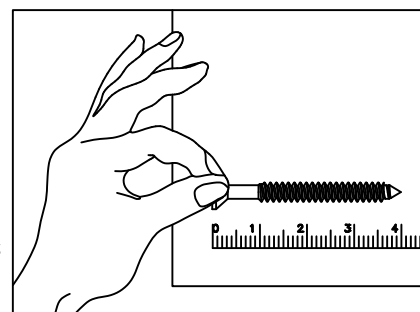





IDENTIFICAÇÃO DOS ACESSÓRIOS/ IDENTIFICACIÓN DE ACCESORIOS/ IDENTIFICATION OF ACCESSORIES

–NOTAS: A separação dos acessórios antes de iniciar a montagem facilitará a mesma. Os parafusos e cavilhas estão na escala real. Em caso de dúvida na identificação, coloque o acessório sobre a imagem.

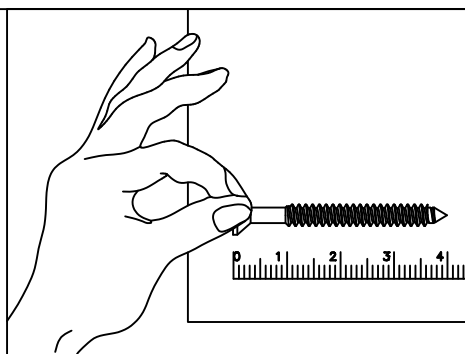
–NOTAS:La separación de los accesorios antes de comenzar el armado facilitará el mismo. Los tornillos y taquetes son en escala real. En caso de dudas sobre la identificación, coloque el accesorio en la imagen.

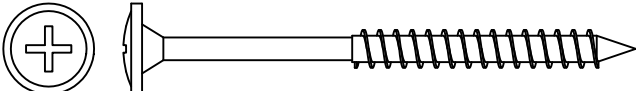
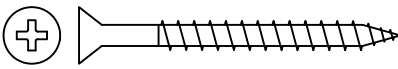
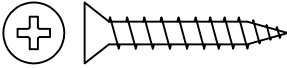
–NOTES:The separation of the accessories before you start the assembly will facilitate the same. The screws and dowels are in real scale. In case of doubts about the identification, place the accessory on the image

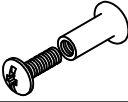
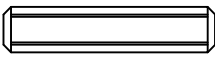
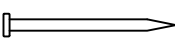
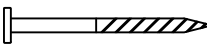

Ferragem / Herrajes / Hardware			
	Código/ Código/ Code	Descrição / Descripción / Description	Quan./ Cant./ Amou.
PF9	50311	 Parafuso flangeado/ Tornillo de cabeza flangead/ Flanged head screw 5,0x65mm	6
PC8	226	 Parafuso chato/ Tornillo de cabeza plana/ Flat head screw 4x40mm	40
PC4	54117	 Parafuso chato/ Tornillo de cabeza plana/ Flat head screw 3,5x25mm	8
PC3	4214	 Parafuso chato/ Tornillo de cabeza plana/ Flat head screw 3,5x14mm	40
PU	8688	 Parafuso união metálico/Tornillo de unión de metal/ Metal union bolt	4
C1	1802	 Cavilha/ Pin/ Wooden Dowel 6x30mm	42
PR1	107	 Prego/Clavo/Nail 10x10mm	28
PR2	108	 Prego/Clavo/Nail 12x12mm	4
EM	58	 Etiqueta marca/Tag label "Kappesberg"	1

Prezado Montador:

– Antes de iniciar a montagem verifique as condições do ambiente de montagem;
– Confira todas as peças das embalagens com a lista de peças contida neste manual;
– Separe os acessórios, confira as medidas dos parafusos com a escala;
– Siga todas as orientações deste manual de montagem para ter o direito à garantia do produto;
– Descarte as embalagens de forma correta, destinando o plástico e o papel para reciclagem;

Estimado Montador:











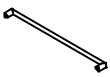



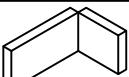

– Antes de iniciar a montagem verifique as condições do ambiente de montagem;
– Confira todas as peças das embalagens com a lista de peças contida neste manual;
– Separe os acessórios, confira as medidas dos parafusos com a escala;
– Siga todas las orientaciones deste manual de montagem para ter o direito à garantia do produto;
– Descarte como embalagens de forma correta, destinando o plástico e o papel para reciclagem;

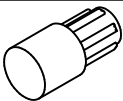
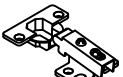
Dear Fitter:

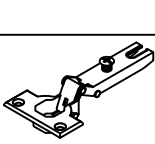

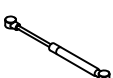
– Before starting montagem check as conditions of the assembly environment;
– Check out all the packaging com a list of fish contained in this manual;
– Separate the accessories, check the measures two parafusos com to scale;
– Follow all the guidelines of this manual montagem para ter or direct to guarantee of the product;
– Discard the packages correctly, allocating either plastic or paper for recycling;



Ferragem / Herrajes / Hardware

	Código/ Código/ Code	Descrição / Descripción / Description	Quan./ Cant./ Amou.
LM	85	 "L" de metal/Cantón "L" de metal/Metal angle bracket "L"	4
PX	63108	 Puxador/Asar/Handle	3
SD	1901	 Sapata deslizadora preta/Zapata negra/Shoe black	4
BC	529	 Bucha invasiva/Adapter sleeve/ Manga del adaptador	6
PH	NGVE/NGFE=14991 (Carvalle)	 Perfil H/Perfil de acabado/Finishing profile	1
GS	40534	 Silicone/Silicona/Selecone	6
TP2	NGFE/NGVE=63102 (Nogueira)	 Tapa furo/Tapa del agujero/Screw cap cover 13mm	32
S10	17024	 Suporte aéreo/Soporte de seguridad/Safety bracket	4
CS	6959	 Capa para suporte /Cubierta de soporte/Support cover	4
CG	899	 Cantoneira/Cantón /Angle bracket	6
S2	118	 Suporte para prateleira/Soporte de estante/Shelf support 6x8mm	6
DO11	51322	 Dobradiça reta calço fixo e amortecedor/Bisagra/Hinge 35mm	4
	61971	 Parafuso da dobradiça/Tornillo del bisagra/Hinge Screw 4,0x14	24
DO8	61969	 Dobradiça super curva/Bisagra/Hinge 35mm	2
	62435	 Calço para dobradiça/Bisagra de calce/Hinge shim	2
	61971	 Parafuso da dobradiça/Tornillo del bisagra/Hinge Screw 4,0x14	4
PG4A		 Pistão a gás/Pistón de gas/Gas piston 40N	1
PG4B	28505		
PG4C			
PG4D			
		Parafuso/ Tornillo/ Screw	

01 PASSO / PASO / STEP

S2		6
C1		42

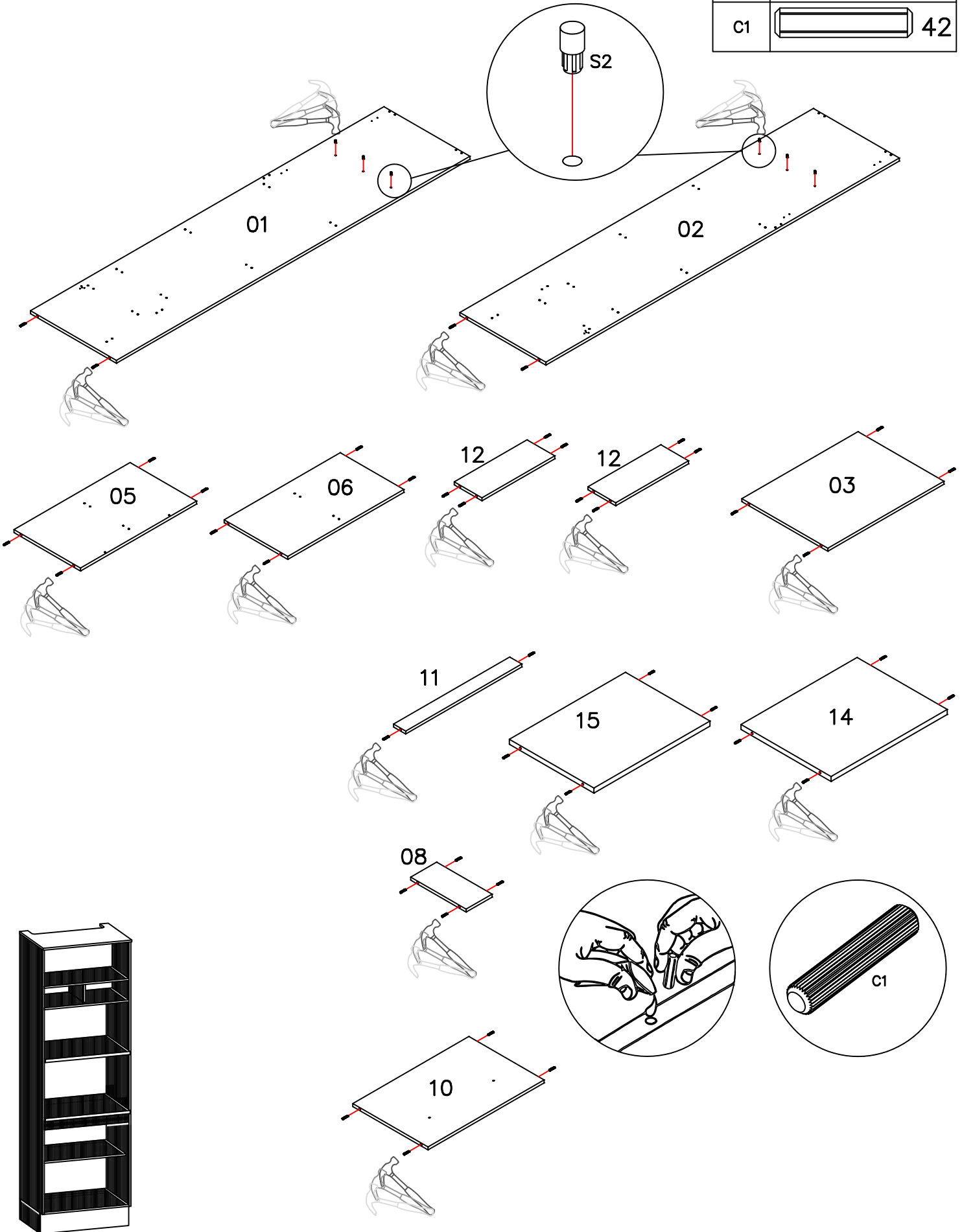

02 PASSO/ PASO/ STEP

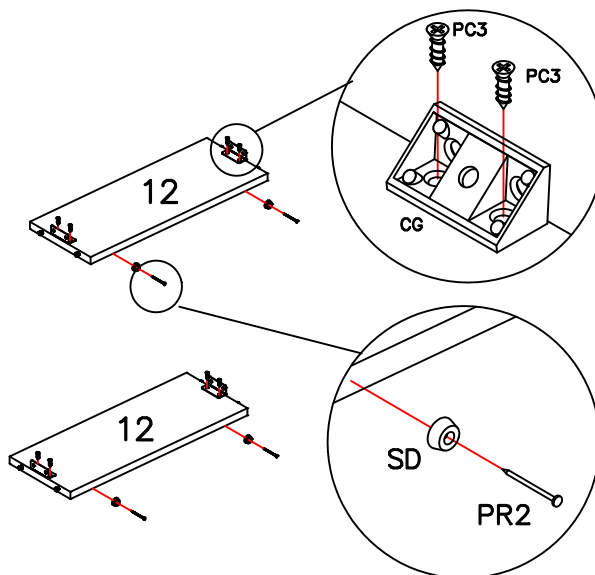
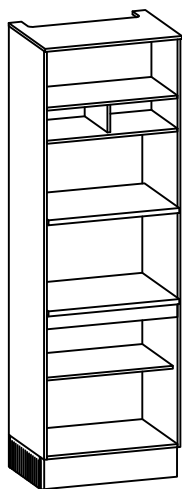

PR2		4
SD		4
CG		4
PC3		8

03 PASSO/ PASO/ STEP

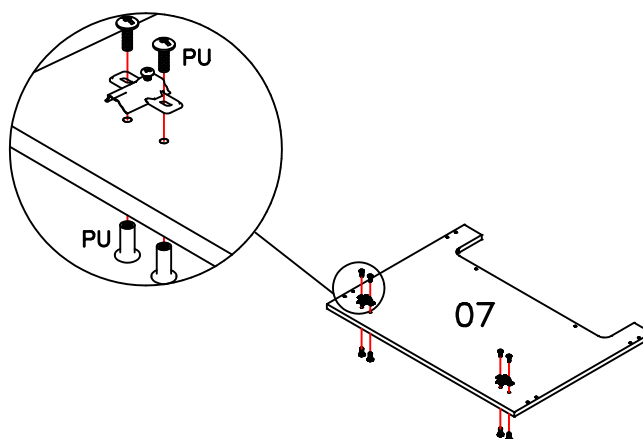
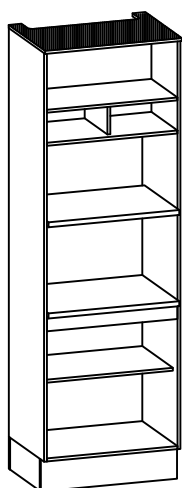

D08		2
PU		4

04 PASSO/ PASO/ STEP

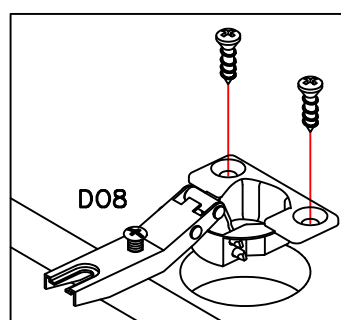
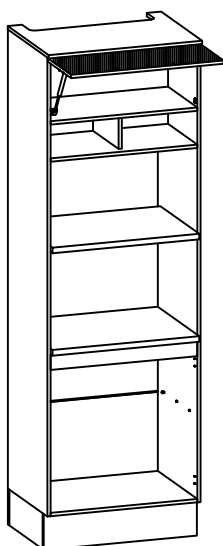

D08		2
D08		4

-ATENÇÃO PARA O ALINHAMENTO DAS DOBRADIÇAS
-ATENCIÓN PARA ALINEAR LAS BISAGRAS
-ATTENTION TO THE ALIGNMENT OF THE HINGES

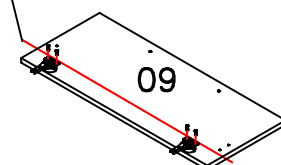

MONTAGEM/ ASSEMBLE/ ARMADO

05 PASSO/ PASO/ STEP

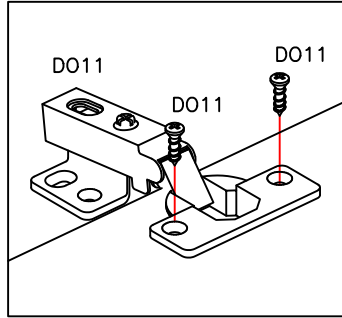
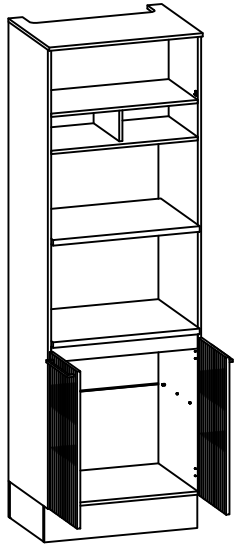

D011		4
D011		8

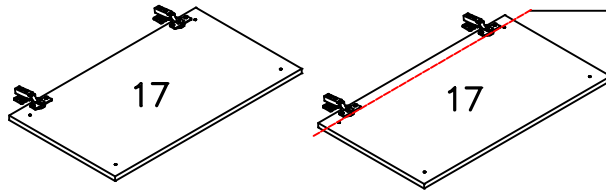

-ATENÇÃO PARA O ALINHAMENTO DAS DOBRADIÇAS
-ATENCIÓN PARA ALINEAR LAS BISAGRAS
-ATTENTION TO THE ALIGNMENT OF THE HINGES

06 PASSO/ PASO/ STEP

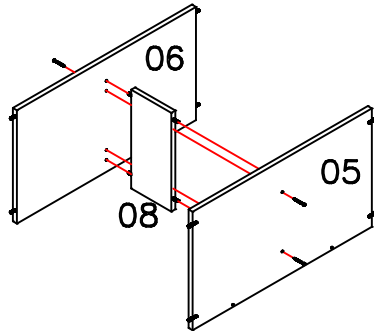
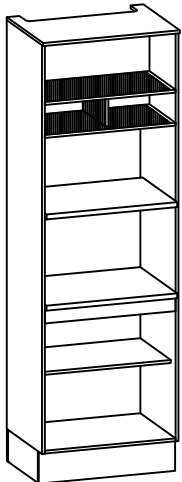

PC8		4
TP2		4

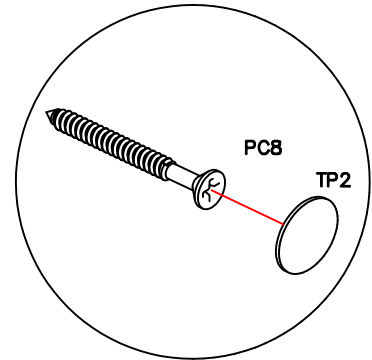

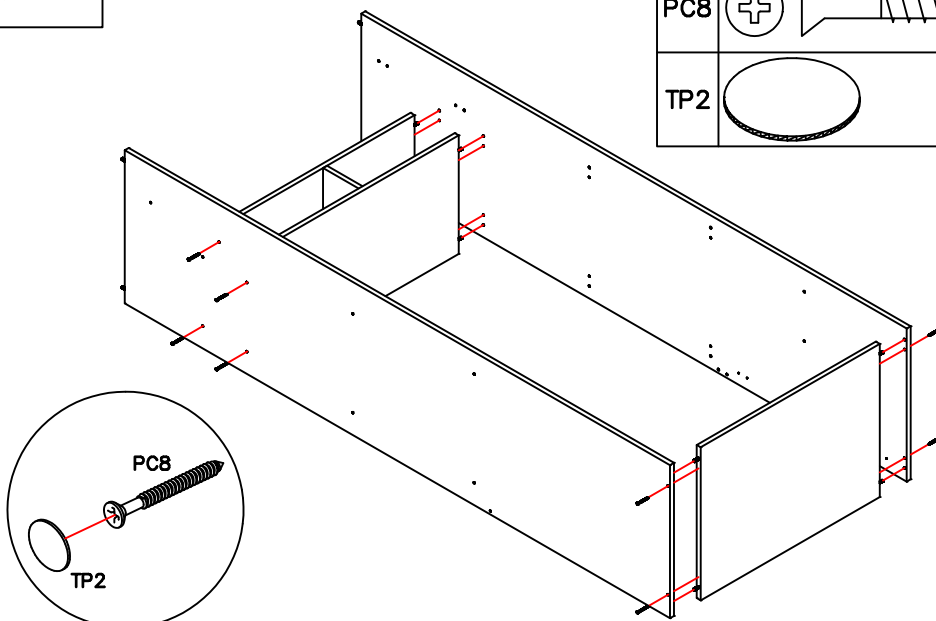
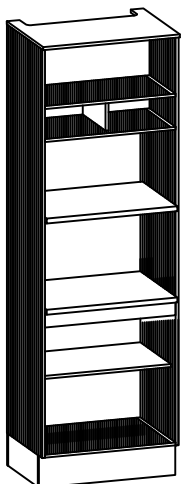

07 PASSO/ PASO/ STEP

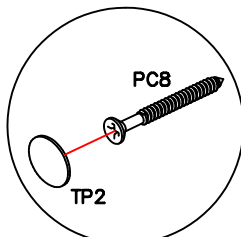

PC8		12
TP2		12



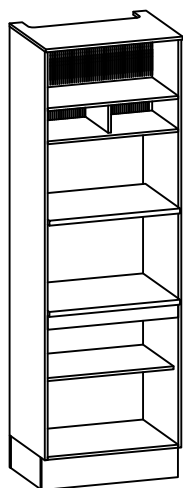
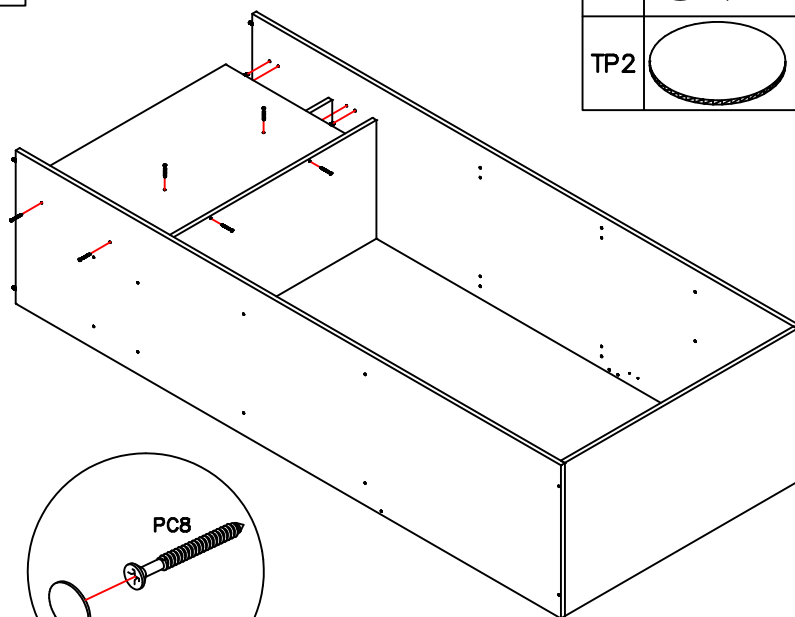

08 PASSO/ PASO/ STEP

PC8		8
TP2		8



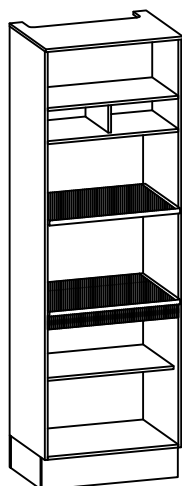
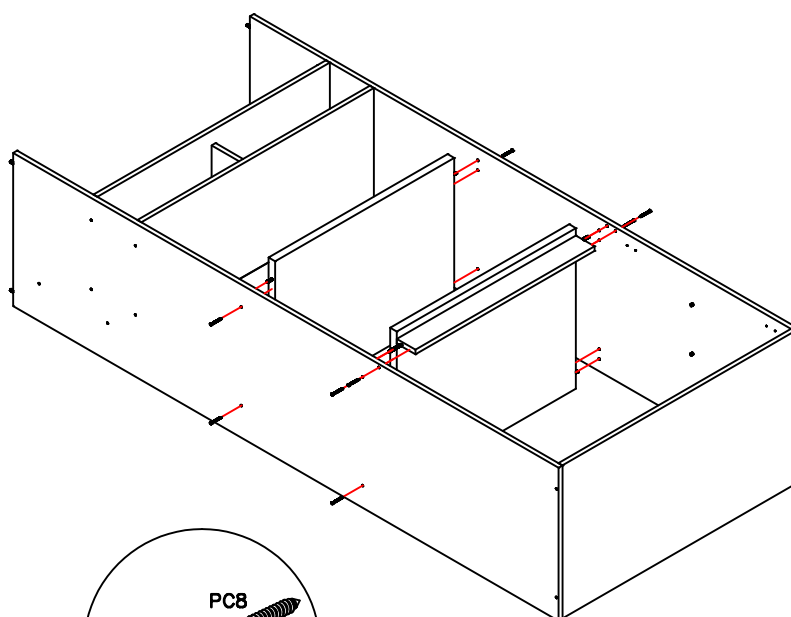

09 PASSO/ PASO/ STEP

PC8		10
TP2		10

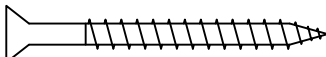

10 PASSO/ PASO/ STEP

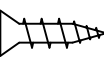
PC8			6
CG			2
PC3			8

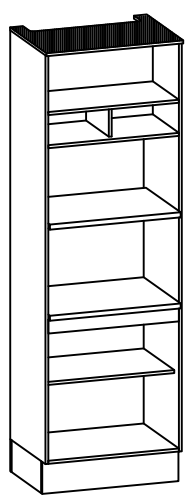
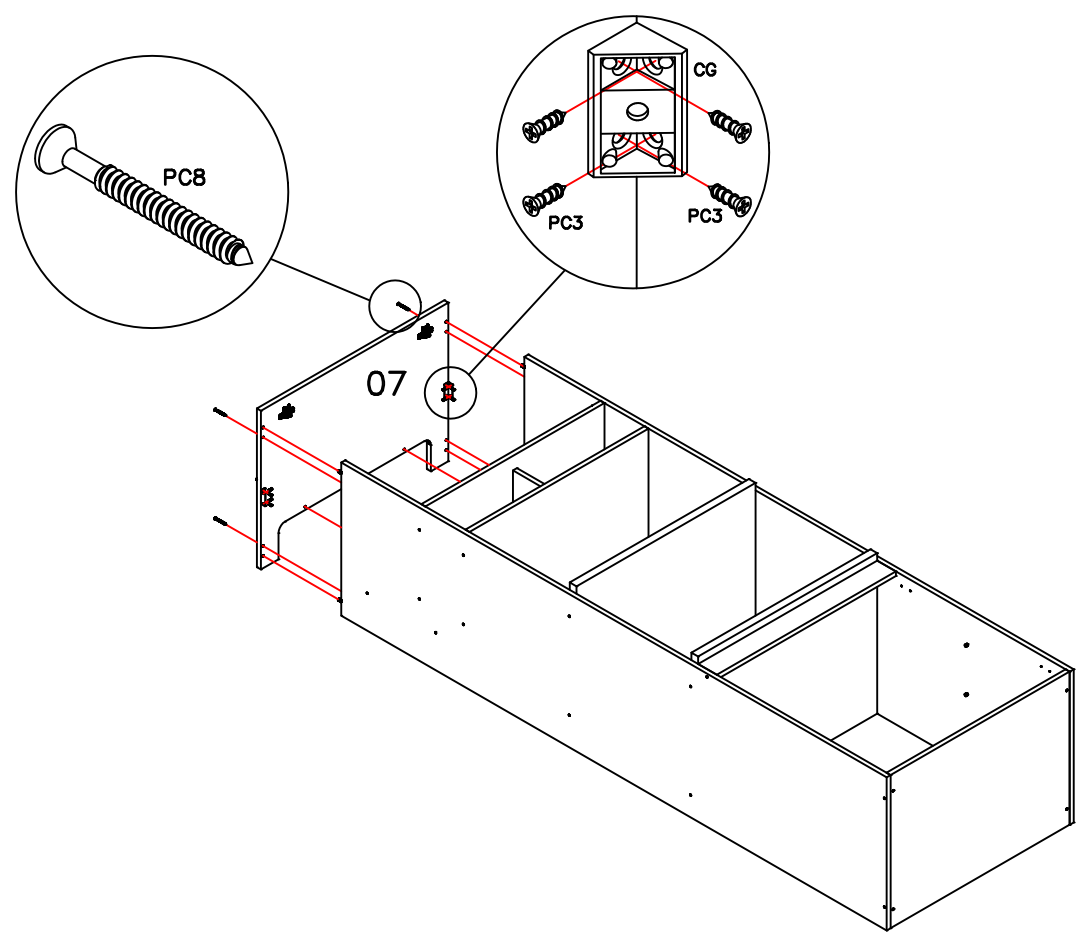

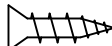

12 PASSO/ PASO/ STEP

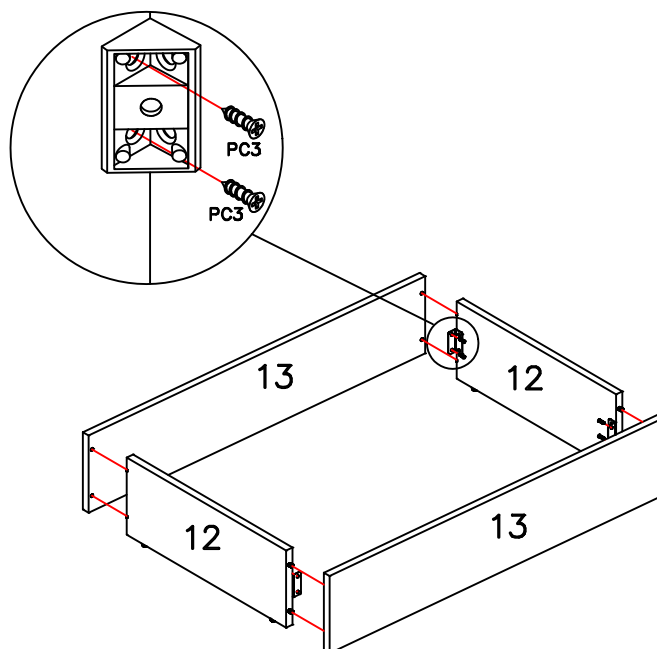
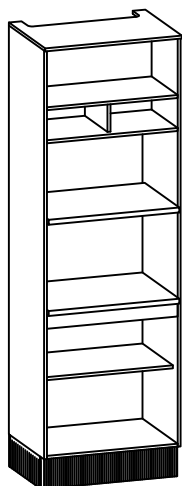
PC3			8
-----	---	---	---

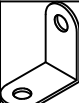

11 PASSO/ PASO/ STEP

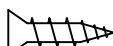
LM		4	
PC3			8

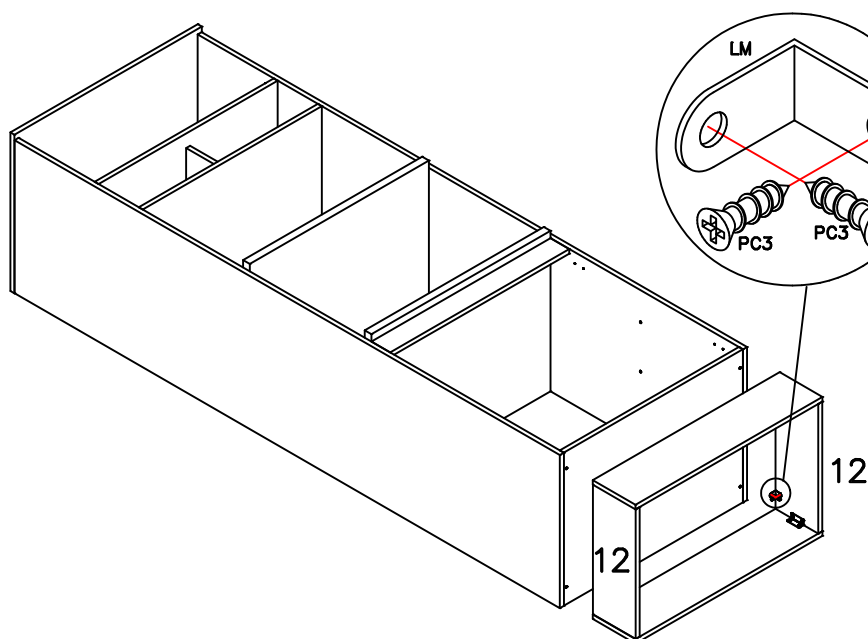
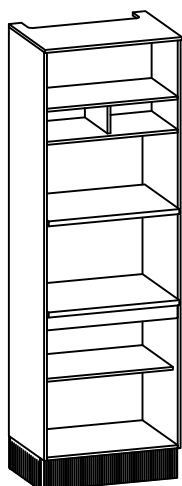

13 PASSO/ PASO/ STEP

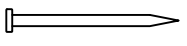
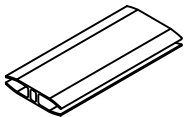
PR1		28
PH		1

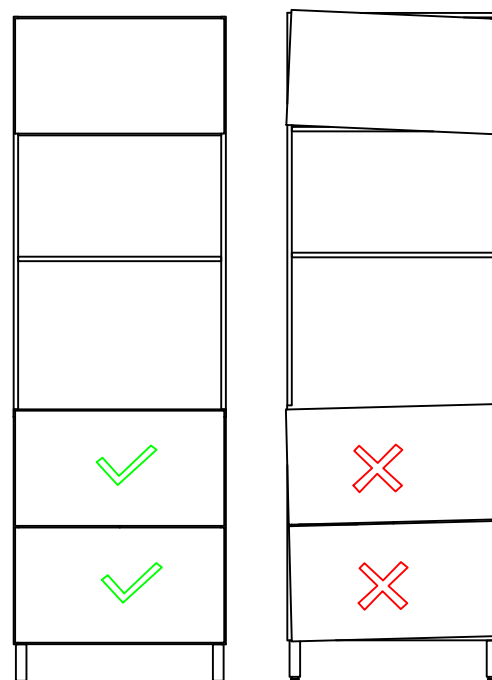
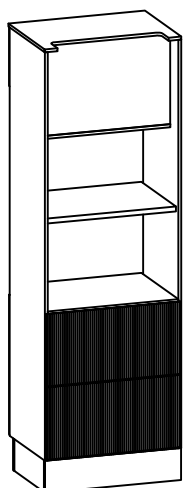
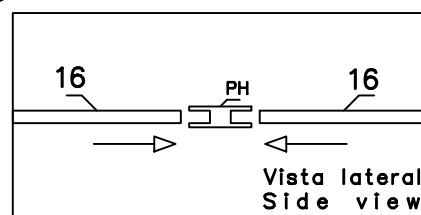
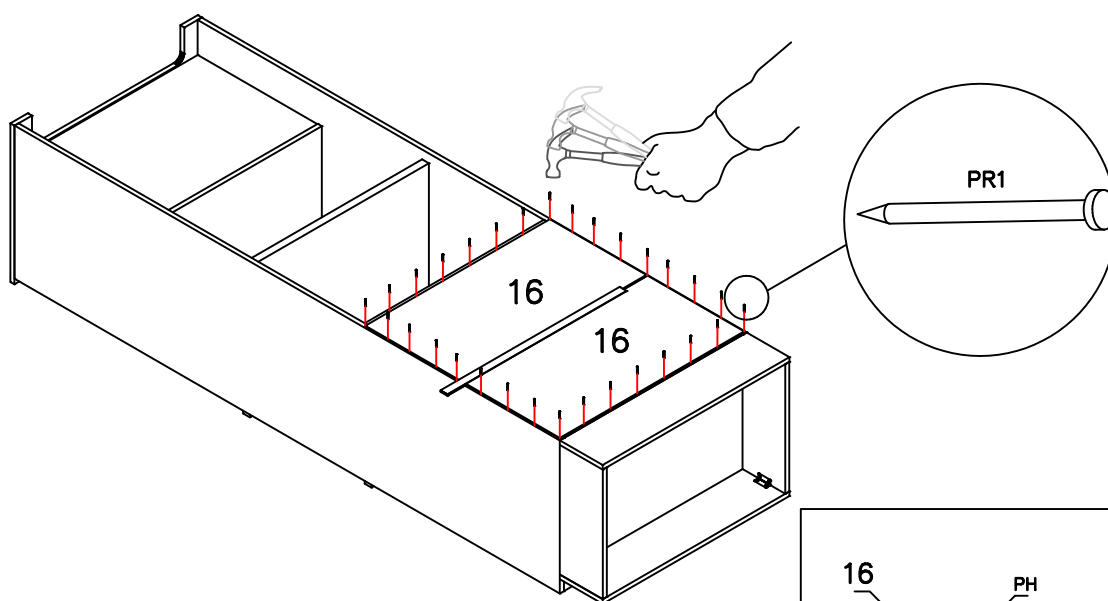

14 PASSO/ PASO/ STEP

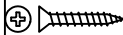
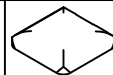
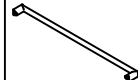
PP1		16
PC4		4
GS		4
PX		2

NOTA: Utilize o furo oblongo para posicionar a altura da dobradiça. E por fim quando a porta estiver posicionada de maneira correta utilize o furo circular para garantir que a mesma não se desloque.

NOTAS: Utilice o furo oblongo para posicionar a altura da dobradiça. E por fim quando a porta estiver posicionada de maneira correta utiliza o furo circular para garantir que a mesma não se desloque.

NOTE: Use the oblong edge to position at the height of the dobradiça. And for this reason, when the estiver holder is positioned in a correct way, use a circular hole to ensure that it does not loosen at the same time.

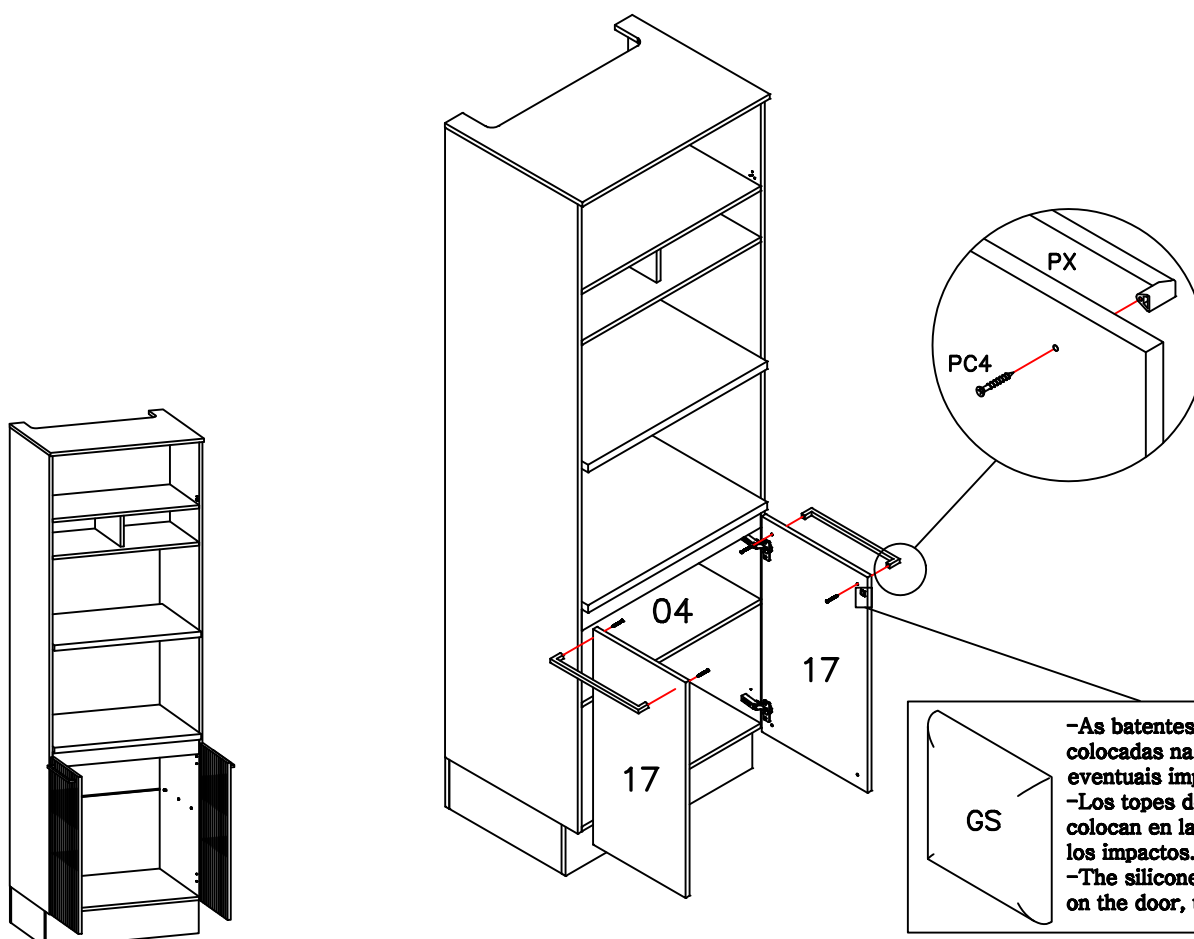
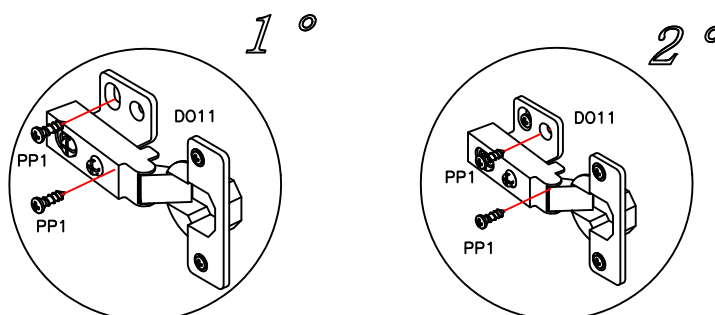

GS

-As batentes de silicone "GS" são colocadas na porta, para suavizar eventuais impactos.
 -Los topes de silicona "GS" se colocan en la puerta, para suavizar los impactos.
 -The silicone stops "GS" are placed on the door, to soften any impacts.

15 PASSO/ PASO/ STEP

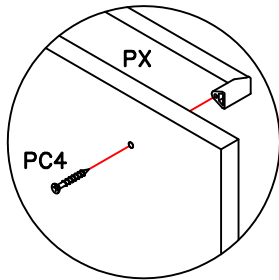
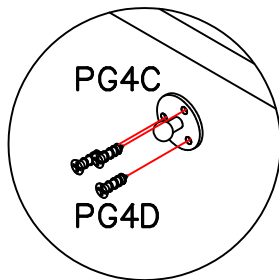
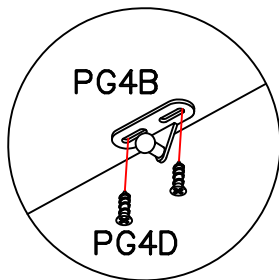
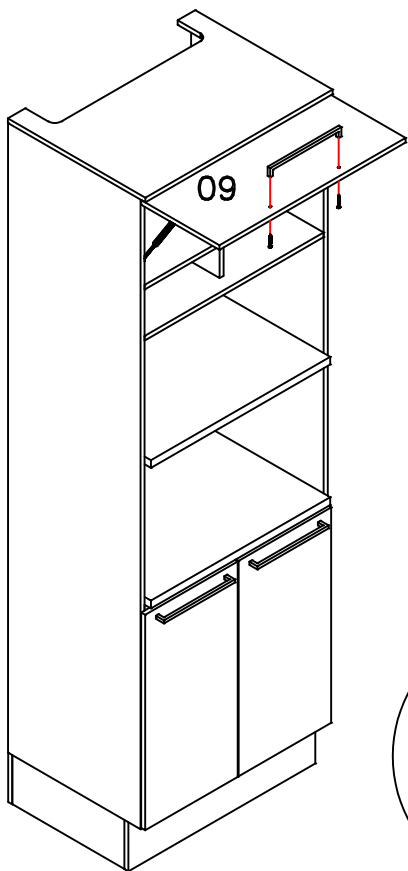

PG4B		1
PG4C		1
PG4D		5
PG4A		1
PC4		2
PX		1
GS		2

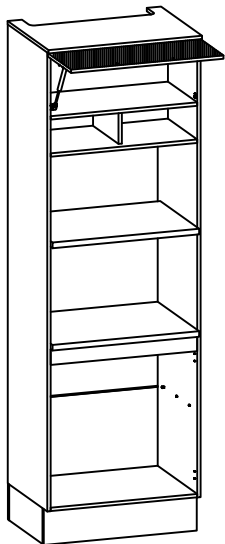
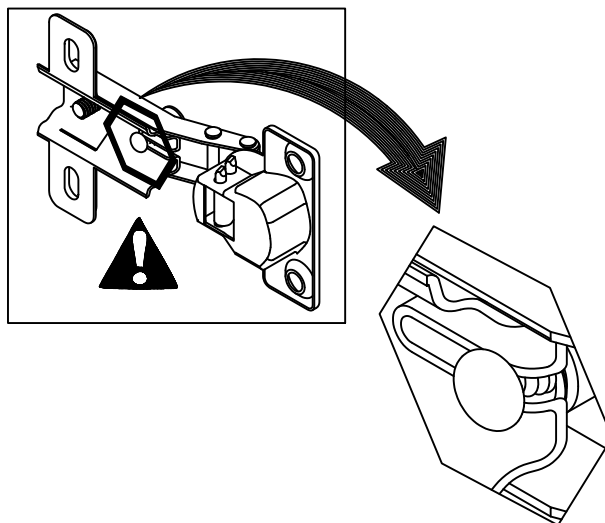
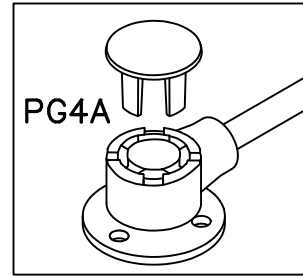
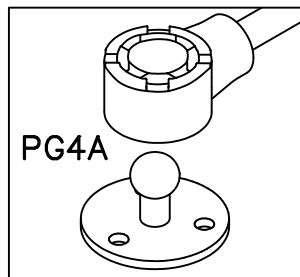
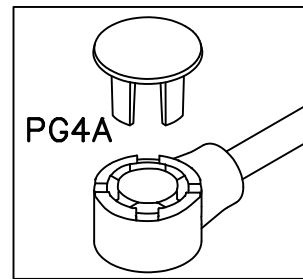
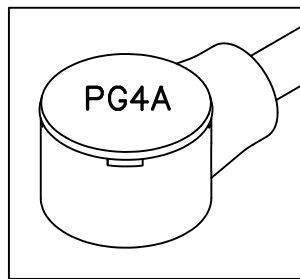
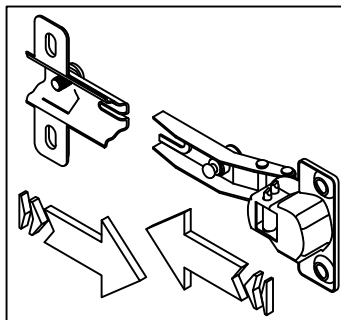
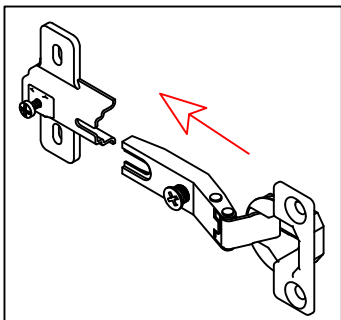

16 AJUSTE DE PORTAS/ AJUSTE DE PUERTA/ DOORS ADJUSTMENT

REGULAGEM VERTICAL/ AJUSTE VERTICAL/ VERTICAL ADJUSTMENT

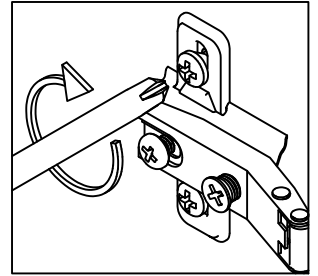
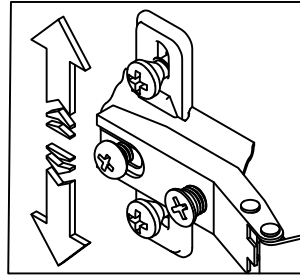
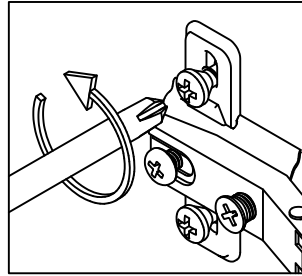
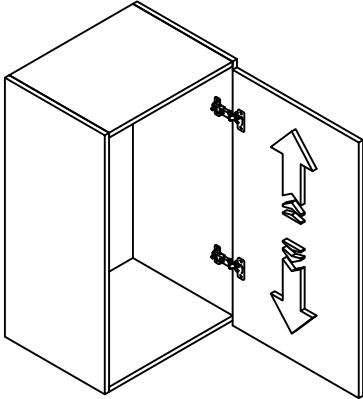

REGULAGEM PROFUNDIDADE/ AJUSTE PROFUNDIDAD/ DEPTH ADJUSTMENT

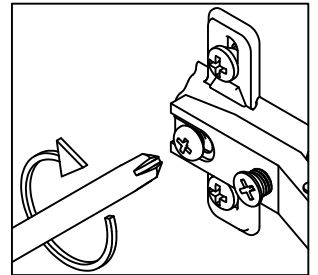
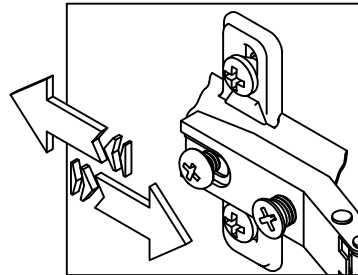
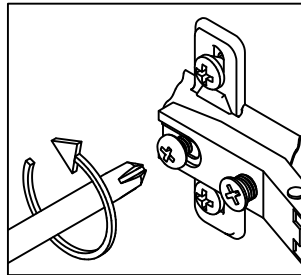
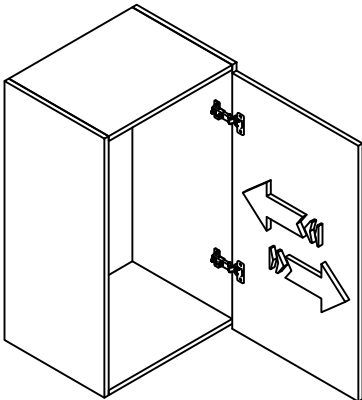



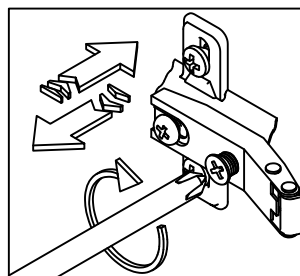
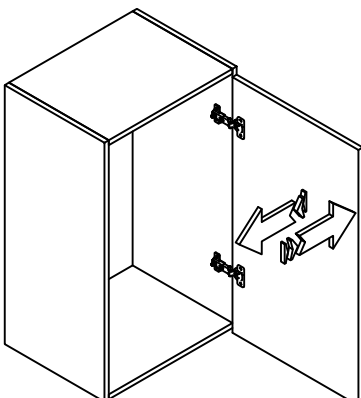



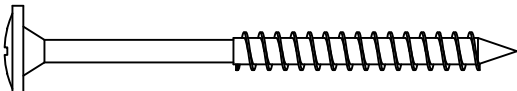

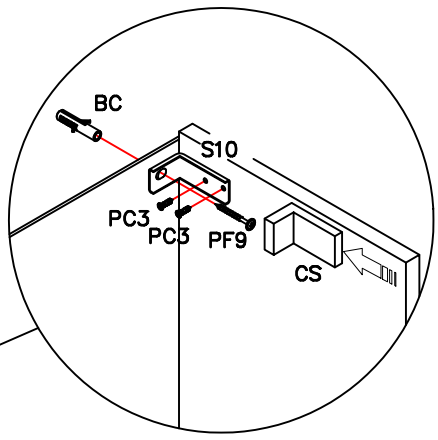
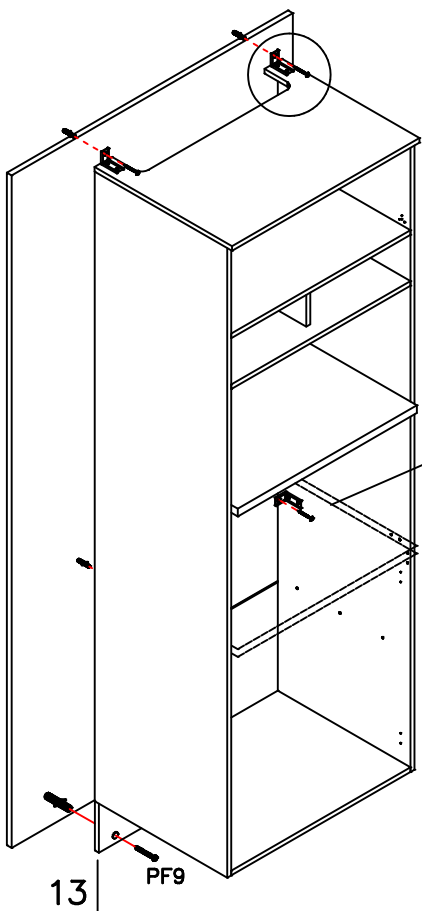

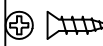
REGULAGEM HORIZONTAL/ AJUSTE HORIZONTAL/ HORIZONTAL ADJUSTMENT



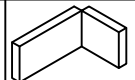
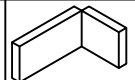

17 PASSO/ PASO/ STEP

PF9			6
-----	---	--	---



PC3			8
PC4			2
S10			4
CS			4
BC			6
TP2			2

 União de Módulos
 Unión de Módulos
 Fasten Cabinets Together

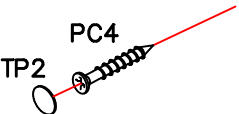

Para montar a cozinha suspensa:

- Utilize o rodapé frontal "13" que acompanha o móvel como apoio para sua fixação na parede, utilizando a bucha "BC" e o parafuso "PF9".
- Em cada lateral fixe um suporte aéreo metalizado "S10" com o parafuso "PC3" e na parede com o parafuso "PF9" e com a bucha "BC".
- Coloque uma capa "CS" em cada suporte "S10".

Para montar la cocina suspendida:

- Utilizar el rodapié frontal "13" que viene con el mueble como soporte para fijarlo a la pared, mediante el casquillo "BC" y el tornillo "PF9".
- En cada lado, fijar un soporte aéreo metalizado "S10" con el tornillo "PC3" y en la pared con el tornillo "PF9" y con el casquillo "BC".
- Colocar una funda "CS" en cada soporte "S10".

To assemble the suspended kitchen:

- Use the front skirting board "13" that comes with the furniture as a support for fixing it on the wall, using the "BC" bushing and the "PF9" screw.
- On each side, fix a metalized aerial support "S10" with the screw "PC3" and on the wall with the screw "PF9" and the bushing "BC".
- Place a cover "CS" on each support "S10".

kappesberg

A montagem deve ser efetuada por UMA pessoa.
El montaje debe ser efectuado por UNA persona.
The assembly must be done by ONE people.



Ferramentas necessárias para montar o móvel
Herramientas necesarias para armar el mueble.
Tools needed to assemble the furniture.

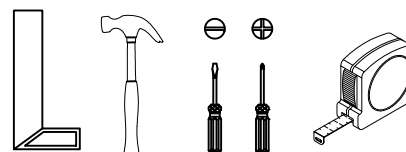

Montar o móvel sobre uma superfície limpa e plana
Armar el mueble sobre una superficie limpia y plana
Assemble the furniture on a clean and flat surface

Y:\Pastas pessoais\Rudimar\Capturar 2.PNG

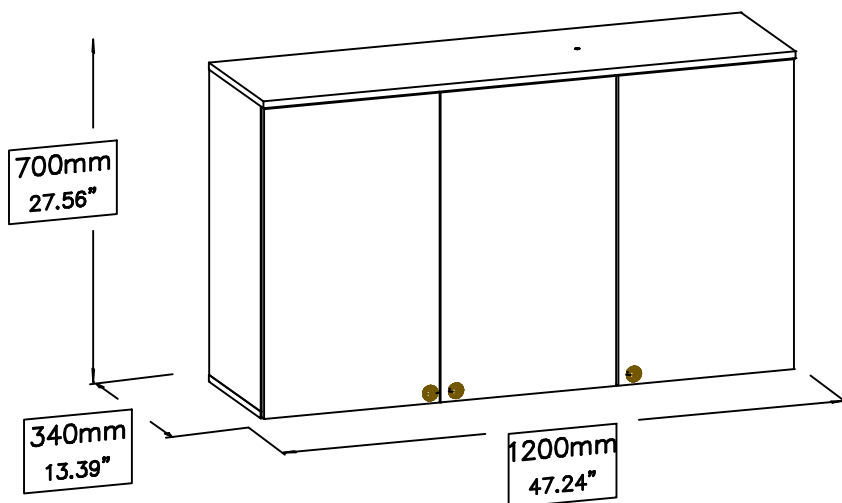

Lista de peças / Lista de piezas / List of pieces

Código / Code	Descrição	Descripción	Description	Quantidade / Cantidad / Amount	Comprimento / Longitud / Length (mm)	Comprimento / Longitud / Length (in.)	Largura / Ancho / Width (mm)	Largura / Ancho / Width (in.)	Espesura / Espesor / Thickness (mm)	Espesura / Espesor / Thickness (in.)	Caixa / Caja / Box
01	Lateral direita	Lateral derecha	Right side	1	670	26.38"	320	12.60"	15	.59"	A
02	Lateral esquerda	Lateral izquierda	Left side	1	670	26.38"	320	12.60"	15	.59"	A
03	Divisória	División	Division	1	670	26.38"	320	12.60"	15	.59"	A
04	Prateleiras maior	Estanterías mayor	Larger Shelf	1	769	30.28"	320	12.60"	15	.59"	A
05	Prateleiras menor	Estanterías pequeña	Smaller shelf	1	385	15.16"	320	12.60"	15	.59"	A
06	Base	Pieza de suelo	Base	1	1200	47.24"	320	12.60"	15	.59"	A
07	Chapéu	Pieza de techo	Top	1	1200	47.24"	338	13.31"	15	.59"	A
08	Porta	Puerta	Door	3	680	26.77"	396	15.59"	15	.59"	A
09	Peça de acabamento			2	326	12.83"	100	3.94"	25	.98"	A
10	Costa	Pieza del fondo	Back panel	2	1190	46.85"	345	13.58"	3	.12"	A

IDENTIFICAÇÃO DAS PEÇAS/ IDENTIFICACIÓN DE LAS PIEZAS/ PARTS IDENTIFICATION

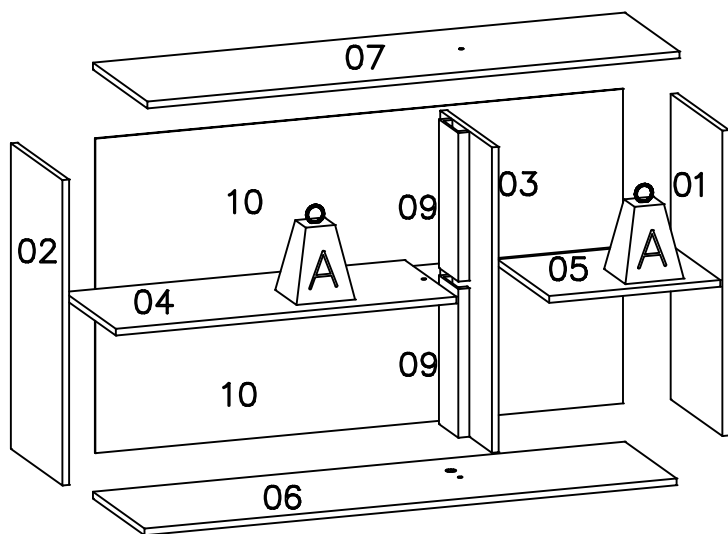
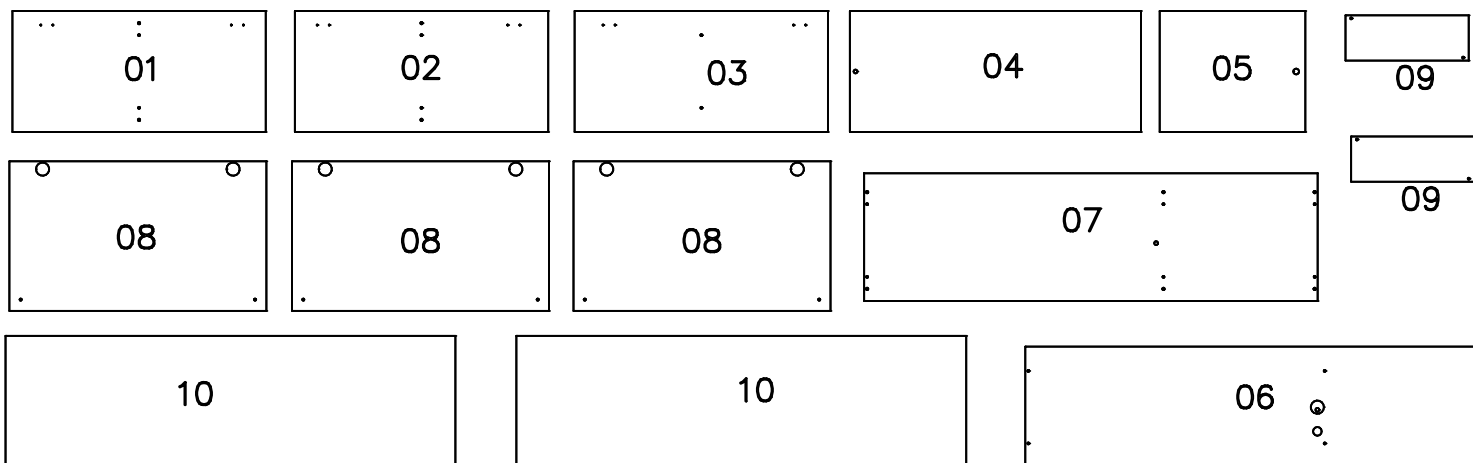

Duvidas? entrar em contato:

¿Dudas? Ponerse en contacto:

Doubts? Get in touch:

Fone: (51) 3635-8839
www.kappesberg.com.br

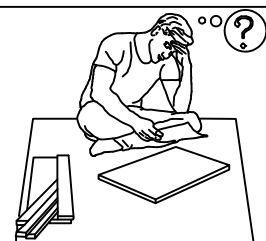

	Kg	lb
A	7	15.43lb

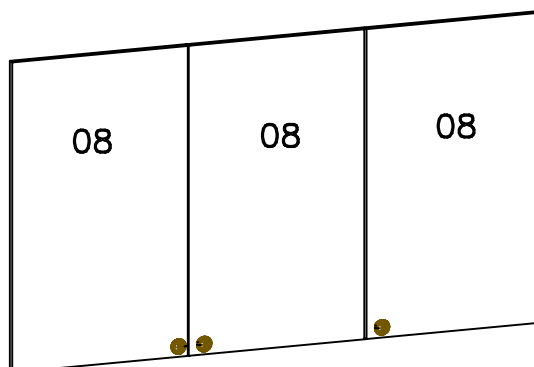

Em caso de dúvida, compare as ferragens com as imagens no decorrer do manual.

En caso de duda, compare el hardware con las imágenes del manual.

If in doubt, compare the hardware with the images throughout the manual

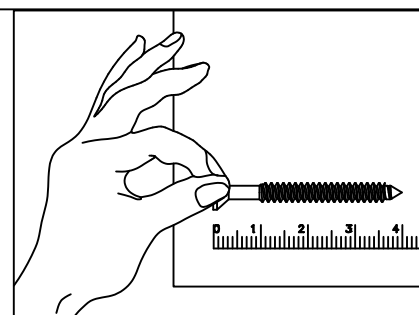

IDENTIFICAÇÃO DOS ACESSÓRIOS/ IDENTIFICACIÓN DE ACCESORIOS/ IDENTIFICATION OF ACCESSORIES



–NOTAS: A separação dos acessórios antes de iniciar a montagem facilitará a mesma. Os parafusos e cavilhas estão na escala real. Em caso de dúvida na identificação, coloque o acessório sobre a imagem.

–NOTAS:La separación de los accesorios antes de comenzar el armado facilitará el mismo. Los tornillos y taquetes son en escala real. En caso de dudas sobre la identificación, coloque el accesorio en la imagen.

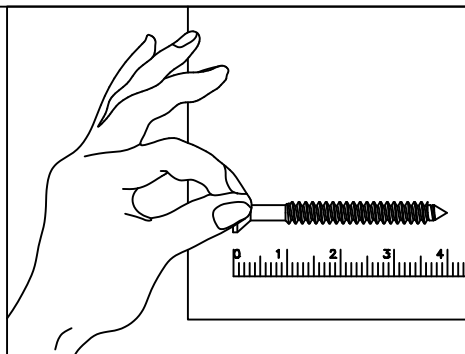
–NOTES:The separation of the accessories before you start the assembly will facilitate the same. The screws and dowels are in real scale. In case of doubts about the identification, place the accessory on the image

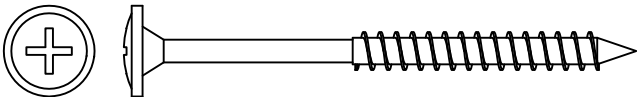
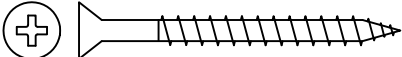
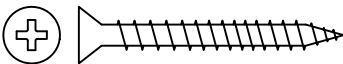
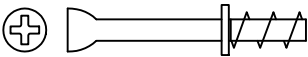
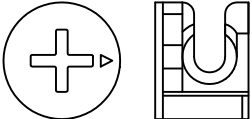
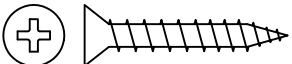

Ferragem / Herrajes / Hardware

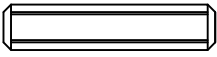
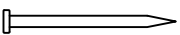
	Código/ Código/ Code	Descrição / Descripción / Description	Quan./ Cant./ Amou.
PF9	50311	 Parafuso flangeado/ Tornillo de cabeza flangead/ Flanged head screw 5,0x65mm	4
PC8	226	 Parafuso chato/ Tornillo de cabeza plana/ Flat head screw 4x40mm	18
PC7	10568	 Parafuso/ Tornillo/ Screw 4x35	4
PM	30945	 Parafuso Minifix/ Tornillo/Connecting Bolt	1
TM	30950	 Tambor Minifix/Cilindro/Minifix Cam	1
PC4	54117	 Parafuso chato/ Tornillo de cabeza plana/ Flat head screw 3,5x25mm	5
PC3	4214	 Parafuso chato/ Tornillo de cabeza plana/ Flat head screw 3,5x14mm	8
C2	1925	 Cavilha/Tarugo/Dowel 6x50mm	2
C1	1802	 Cavilha/ Pin/ Wooden Dowel 6x30mm	16
PR1	107	 Prego/Clavo/Nail 10x10mm	50

Prezado Montador:

– Antes de iniciar a montagem verifique as condições do ambiente de montagem;
– Confira todas as peças das embalagens com a lista de peças contida neste manual;
– Separe os acessórios, confira as medidas dos parafusos com a escala;
– Siga todas as orientações deste manual de montagem para ter o direito à garantia do produto;
– Descarte as embalagens de forma correta, destinando o plástico e o papel para reciclagem;

Estimado Montador:





– Antes de iniciar a montagem verifique as condições do ambiente de montagem;
– Confira todas as peças das embalagens com a lista de peças contida neste manual;
– Separe os acessórios, confira as medidas dos parafusos com a escala;
– Siga todas las orientaciones deste manual de montaje para ter o direito à garantia do produto;
– Descarte como embalagens de forma correta, destinando o plástico e o papel para reciclagem;

Dear Fitter:

– Before starting montagem check as conditions of the assembly environment;
– Check out all the packaging com a list of fish contained in this manual;
– Separate the accessories, check the measures two parafuses com to scale;
– Follow all the guidelines of this manual montagem for ter or direct to guarantee of the product;
– Discard the packages correctly, allocating either plastic or paper for recycling;



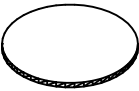
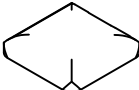
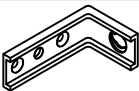
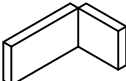
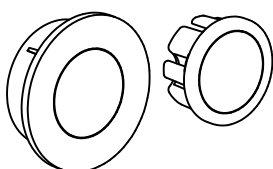
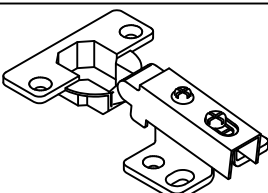
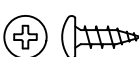

Ferragem / Herrajes / Hardware

	Código/ Código/ Code	Descrição / Descripción / Description	Quan./ Cant./ Amou.
PX	63109	 Puxador/Asar/Handle	3
BC	529	 Bucha invasa/Adapter sleeve/ Manga del adaptador	4
FC	1423	 Fixador de costa/Fijador de costa/Shore Fixer	12
EM	58	 Etiqueta marca/Tag label "Kappesberg"	1
TP2	NG=63102 (Nogueira)	 Tapa furo/Tapa del agujero/Screw cap cover 13mm	22
GS	40534	 Silicone/Silicona/ Selecone	3
S10	17024	 Suporte aéreo/Suporte de seguridad/Safety bracket	4
CS	6959	 Capa para suporte /Cubierta de soporte/Support cover	4
LED	64830	 Kit led/LED kit	1
DO11	51322	 Dobradiça reta calço fixo e amortecedor/Bisagra/Hinge 35mm	6
	61971	 Parafuso da dobradiça/Tornillo del bisagra/Hinge Screw 4,0x14	36



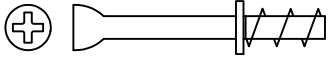

PRÉ-MONTAGEM/ PRE-ASSEMBLE/ PRE ARMADO

01 PASSO/ PASO/ STEP

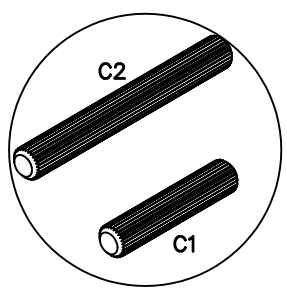
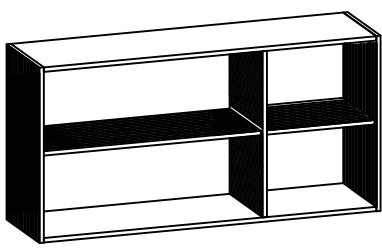
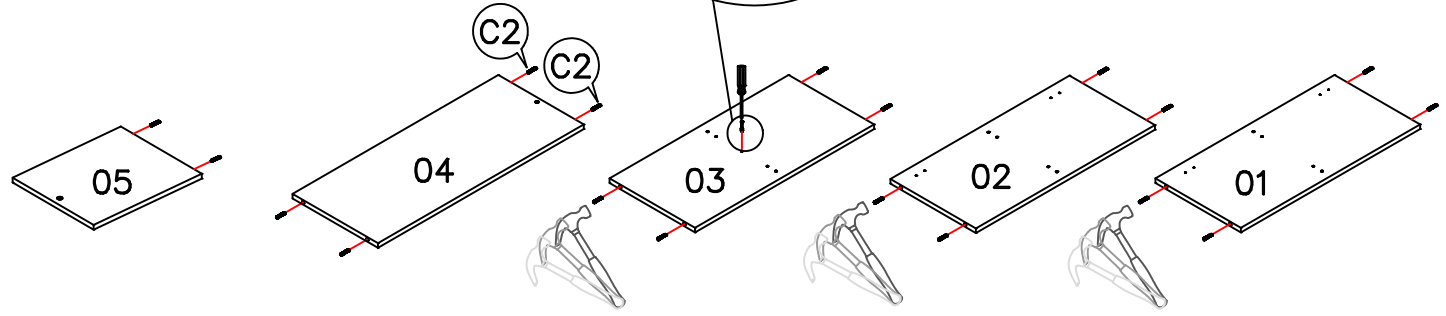
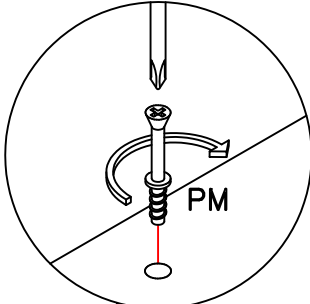
C2		2
C1		16
PM		1

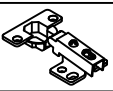

02 PASSO/ PASO/ STEP

DO11		6
DO11		12

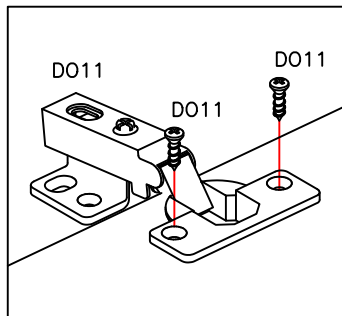

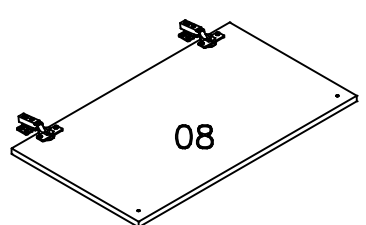
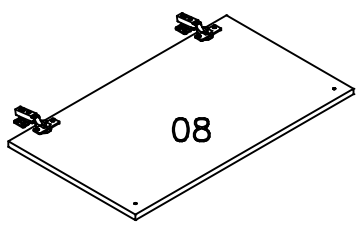
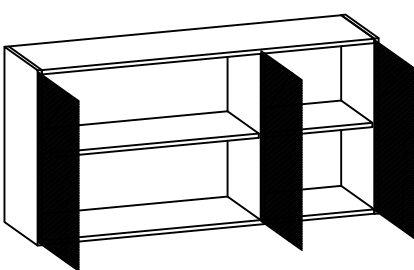
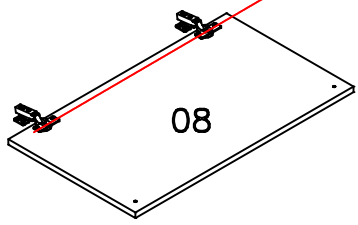

 -ATENÇÃO PARA O ALINHAMENTO DAS DOBRADIÇAS
 -ATENCIÓN PARA ALINEAR LAS BISAGRAS
 -ATTENTION TO THE ALIGNMENT OF THE HINGES

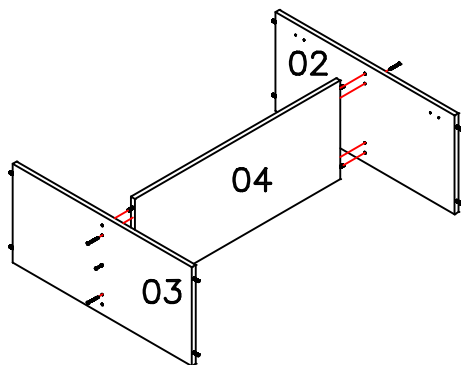

03 PASSO/ PASO/ STEP

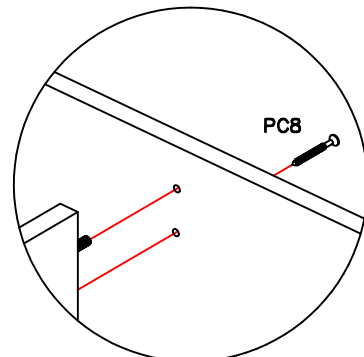
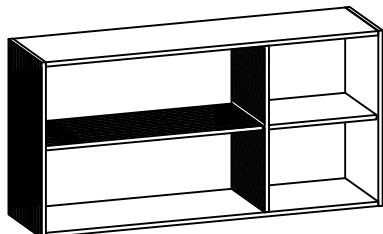

PC8		4
TP2		2



04 PASSO/ PASO/ STEP

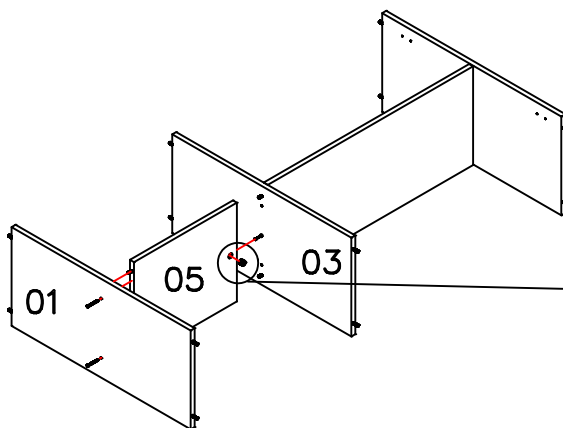
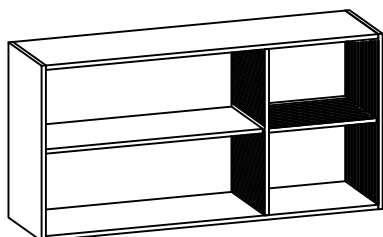
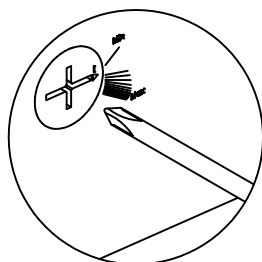

PC8		2
TP2		2
TM		1

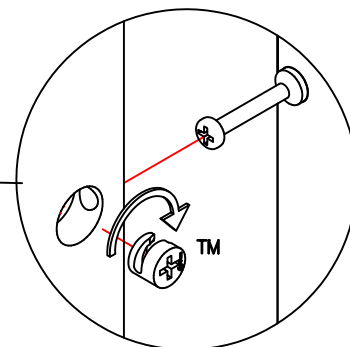

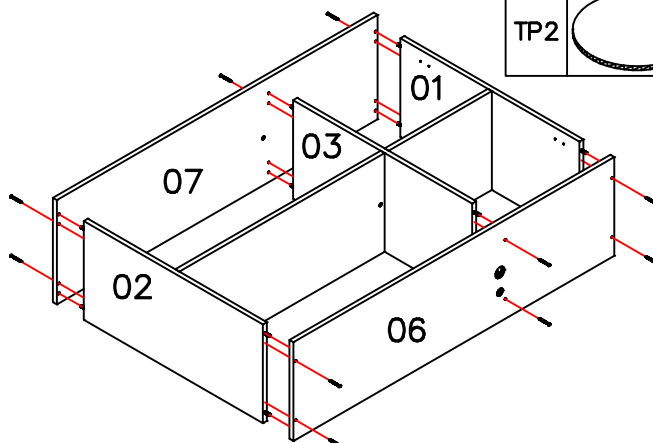
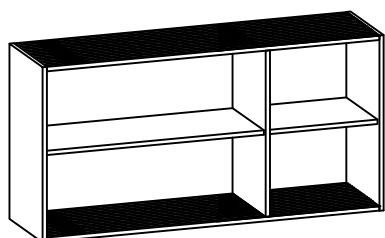

05 PASSO/ PASO/ STEP

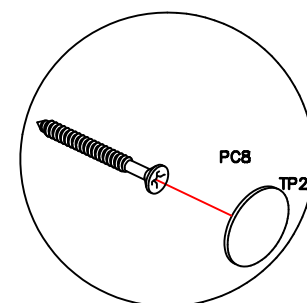

PC8		12
TP2		12

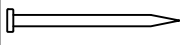

06 PASSO/ PASO/ STEP

PR1		50
FC		12

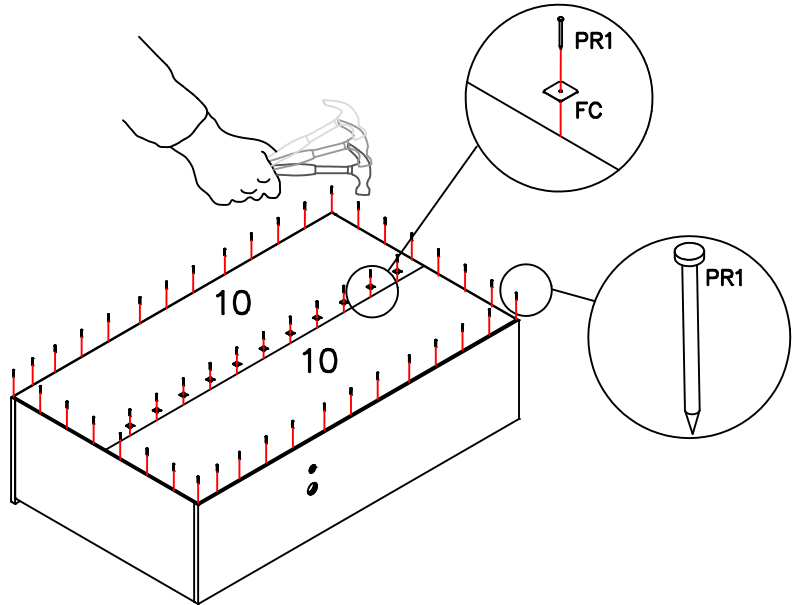
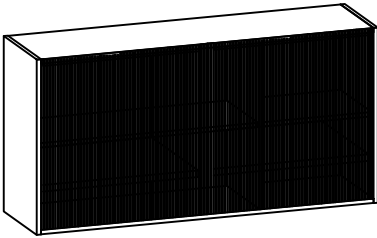

07 PASSO/ PASO/ STEP

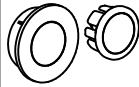
LED		1
-----	---	---

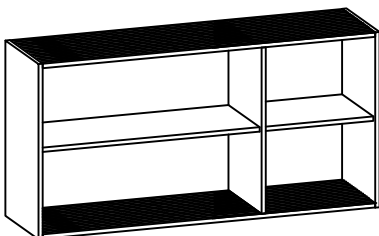
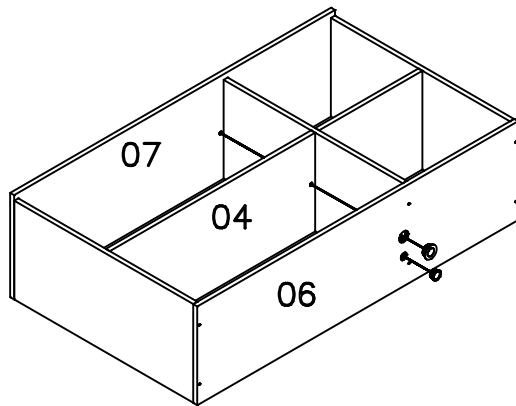

08 PASSO/ PASO/ STEP

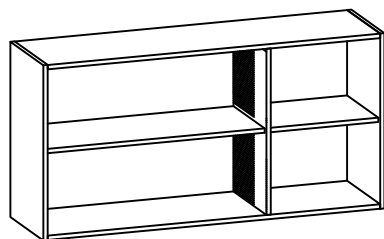
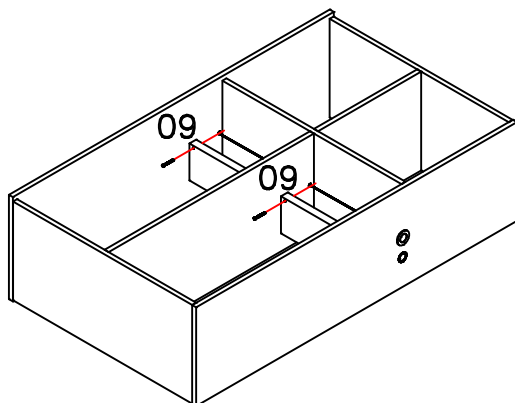

PC7		4
TP2		4

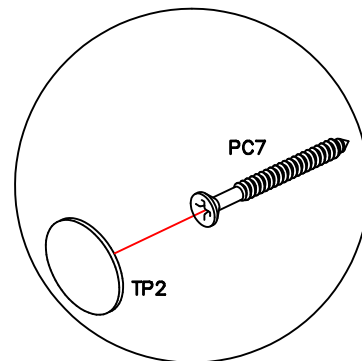

09 PASSO/ PASO/ STEP

NOTA: Utilize o furo oblongo para posicionar a altura da dobradiça. E por fim quando a porta estiver posicionada de maneira correta utilize o furo circular para garantir que a mesma não se desloque.

NOTAS: Utilice o furo oblongo para posicionar a altura da dobradiça. E por fim quando a porta estiver posicionada de maneira correta utilize o furo circular para garantir que a mesma não se desloque.

NOTE: Use the oblong edge to position at the height of the dobradiça. And for this reason, when the estiver holder is positioned in a correct way, use a circular hole to ensure that it does not loosen at the same time.

DO11		24
PC4		3
PX		3
GS		3

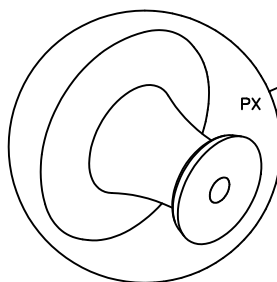
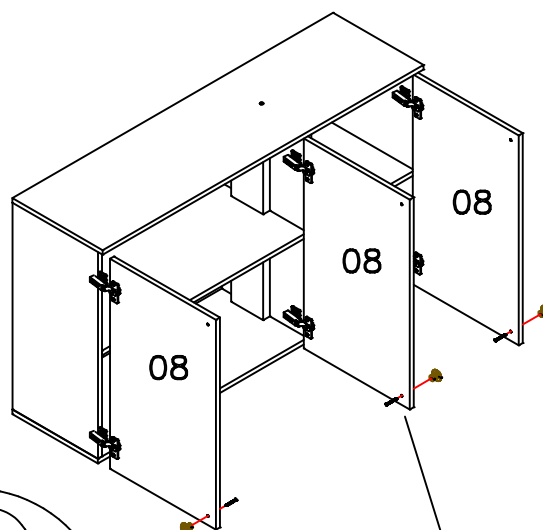
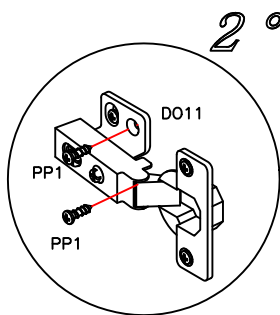
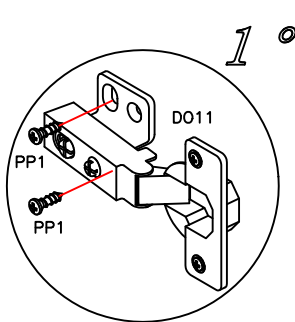

GS

- As batentes de silicone "GS" são colocadas na porta, para suavizar eventuais impactos.
- Los topes de silicona "GS" se colocan en la puerta, para suavizar los impactos.
- The silicone stops "GS" are placed on the door, to soften any impacts.

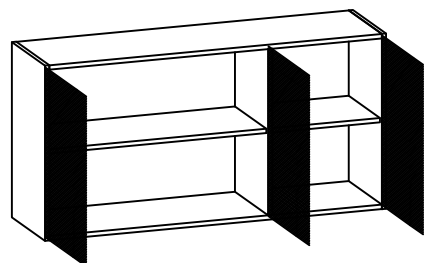

10 AJUSTE DE PORTAS/ AJUSTE DE PUERTA/ DOORS ADJUSTMENT

REGULAGEM VERTICAL/ AJUSTE VERTICAL/ VERTICAL ADJUSTMENT

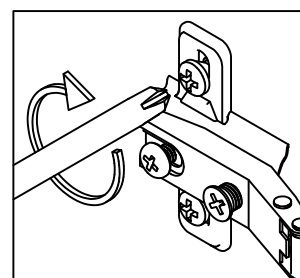
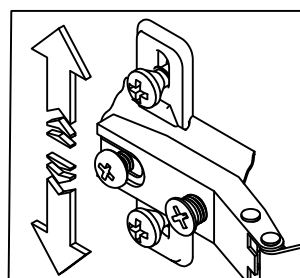
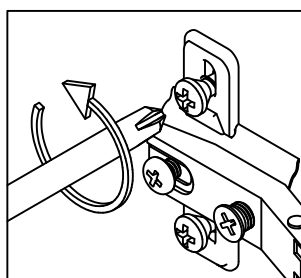
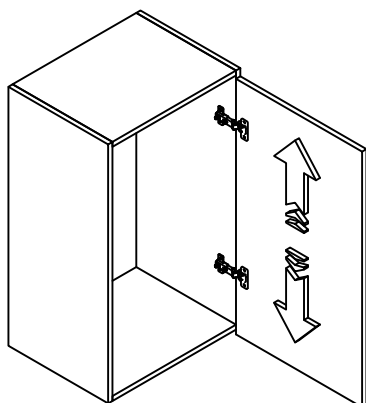



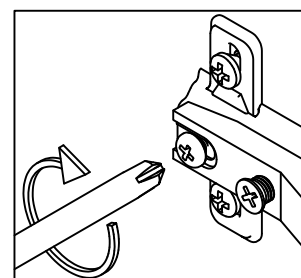
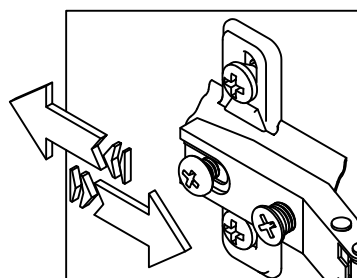
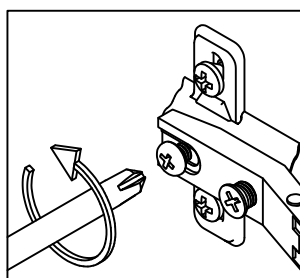
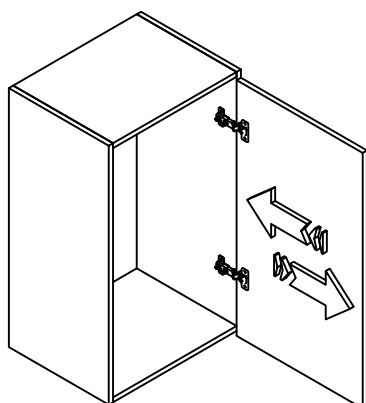

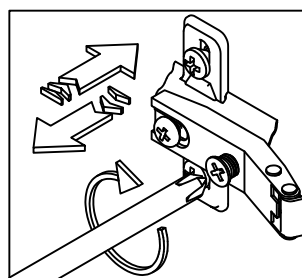
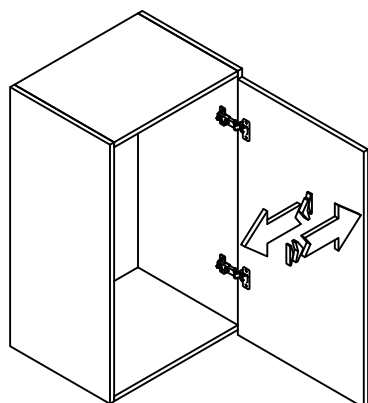

REGULAGEM PROFUNDIDADE/ AJUSTE PROFUNDIDAD/ DEPTH ADJUSTMENT



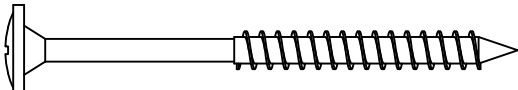

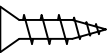

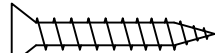
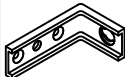
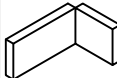
REGULAGEM HORIZONTAL/ AJUSTE HORIZONTAL/ HORIZONTAL ADJUSTMENT

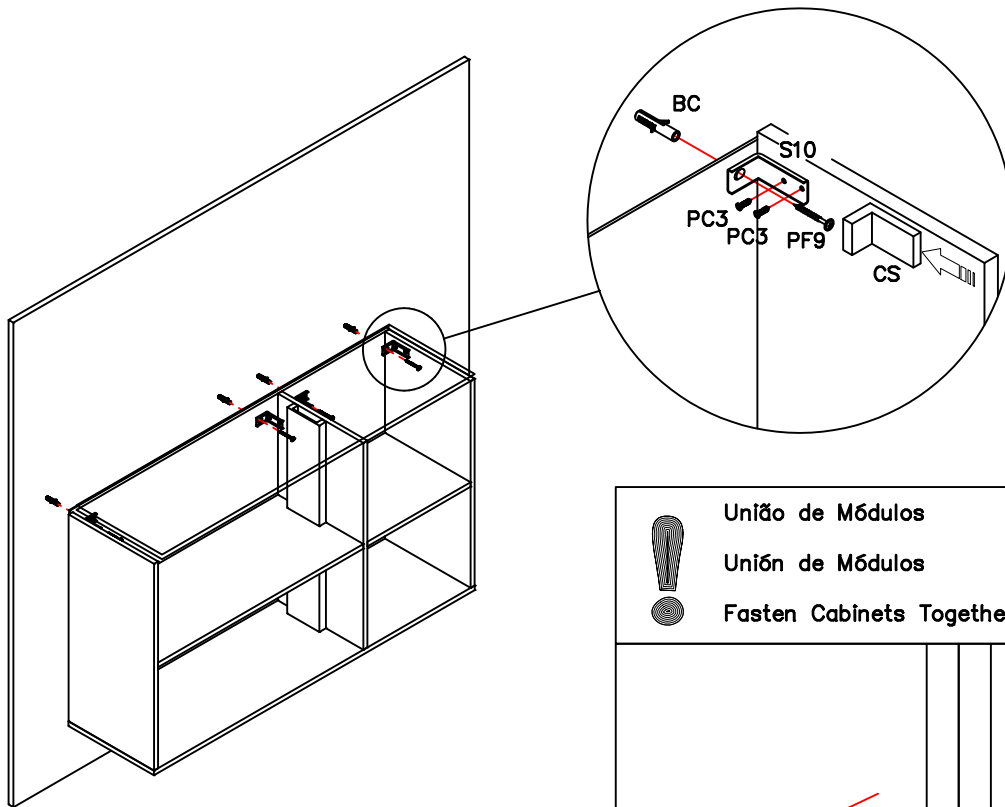

11 PASSO/ PASO/ STEP

PF9			4
PC3			8
PC4			2
S10			4
CS			4
BC			4
TP2			2



	União de Módulos
	Unión de Módulos
	Fasten Cabinets Together

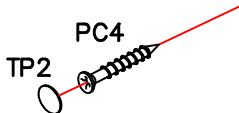

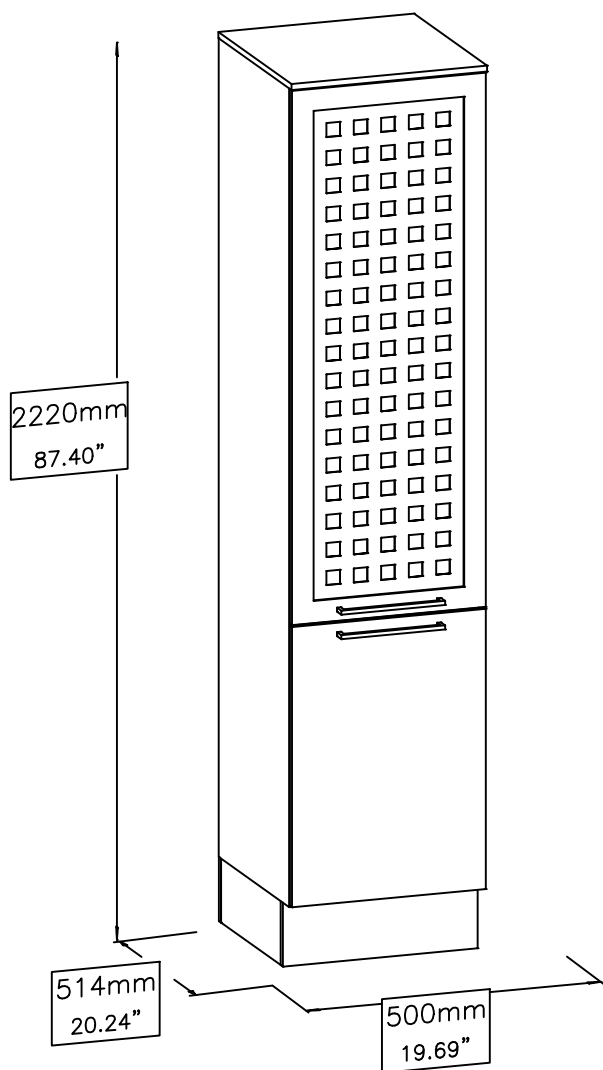

A montagem deve ser efetuada por UMA pessoa.
El montaje debe ser efectuado por UNA persona
The assembly must be done by ONE people



Ferramentas necessárias para montar o móvel
Herramientas necesarias para armar el mueble.
Tools needed to assemble the furniture.

Montar o móvel sobre uma superfície limpa e plana
Armar el mueble sobre una superficie limpia y plana
Assemble the furniture on a clean and flat surface

Y:\Pastas pessoais\Rudimar\Capturar 2.PNG

Lista de peças / Lista de piezas / List of pieces											
Código / Code	Descrição	Descripción	Description	Quantidade / Cantidad / Amount	Comprimento / Longitud / Length (mm)	Comprimento / Longitud / Length (in.)	Largura / Ancho / Width (mm)	Largura / Ancho / Width (in.)	Espessura / Espesor / Thickness (mm)	Espessura / Espesor / Thickness (in.)	Caixa / Caja / Box
01	Lateral direita	Lateral derecha	Right side	1	2040	80.31"	496	19.53"	15	.59"	A
02	Lateral esquerda	Lateral izquierda	Left side	1	2040	80.31"	496	19.53"	15	.59"	A
03	Base	Pieza de suelo	Bottom/Base	1	470	18.50"	496	19.53"	15	.59"	B
04	Tampo das portas	Panel superior	Top	1	470	18.50"	496	19.53"	15	.59"	B
05	Chapéu	Pieza de techo	Top	1	501	19.72"	514	20.24"	15	.59"	B
06	Prateleira	Estanterías	Shelf	4	470	18.50"	430	16.93"	15	.59"	B
07	Rodapé lateral	Falda lateral	Side Skirting	2	420	16.54"	160	6.30"	15	.59"	B
08	Rodapé	Zócalo	Baseboard	2	499	19.65"	160	6.30"	15	.59"	B
09	Costas	Pieza del fondo	Back panel	1	2045	80.51"	490	19.29"	3	.12"	A
10	Porta menor	Puertas más pequeña	Smaller door	1	698	27.48"	496	19.53"	15	.59"	A

IDENTIFICAÇÃO DAS PEÇAS/ IDENTIFICACIÓN DE LAS PIEZAS/ PARTS IDENTIFICATION

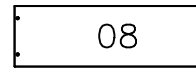
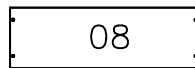
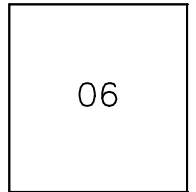
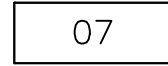
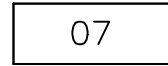
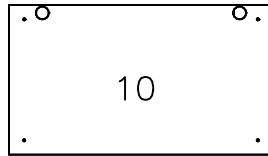
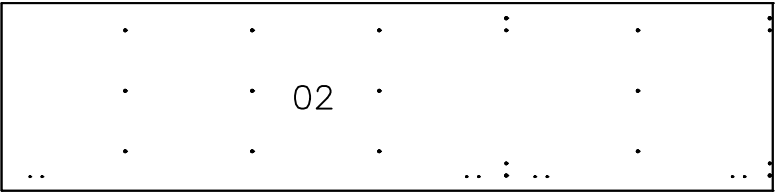
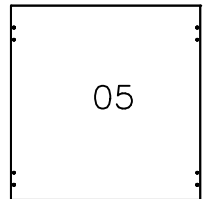
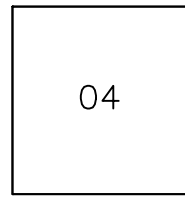
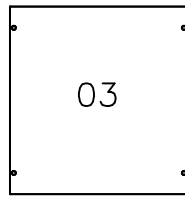
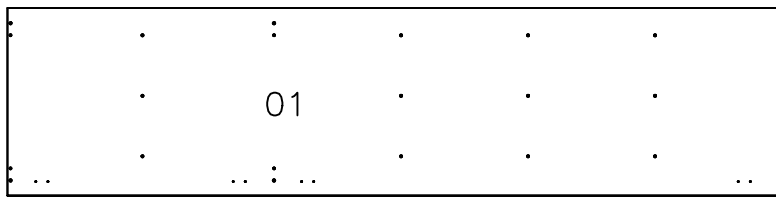

4x

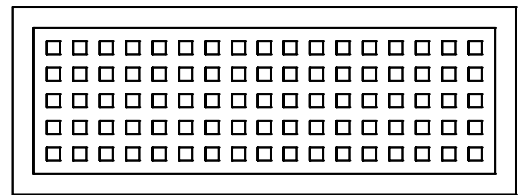

PO

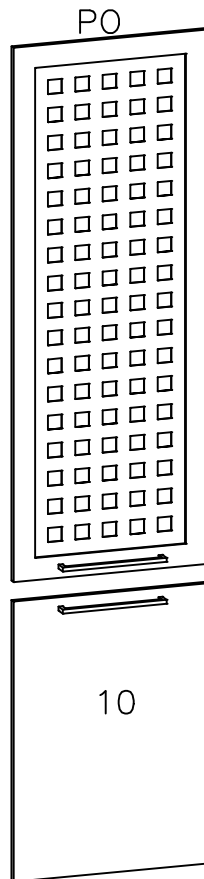
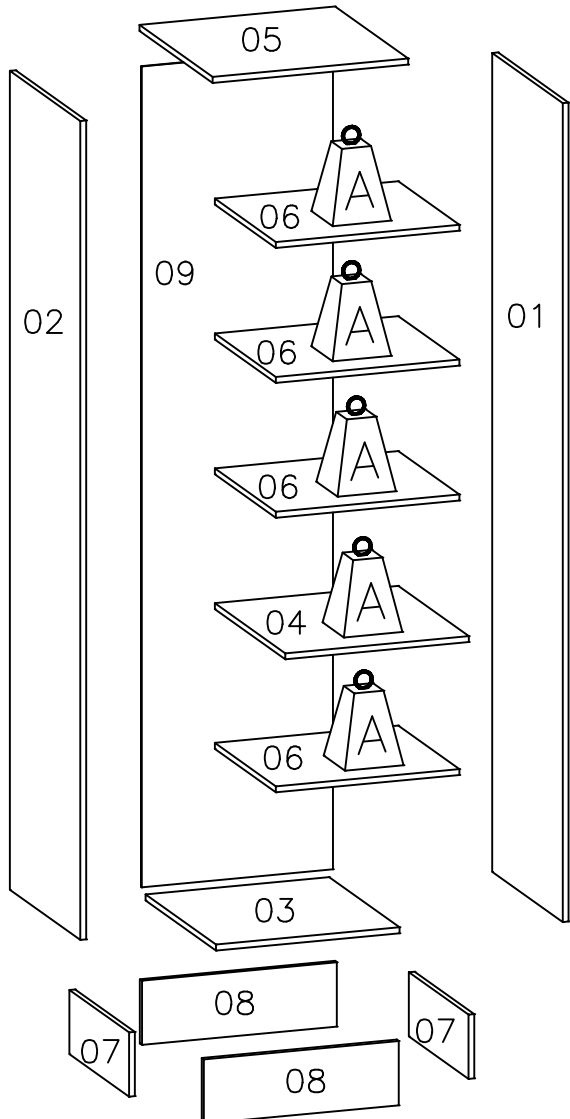

	Kg	lb
A	7	15.43lb

Duvidas? entrar em contato:
¿Dudas? Ponerse en contacto:
Doubts? Get in touch:

Fone: (51) 3635-8839
www.kappesberg.com.br



NOTE: Este produto pode ser montado com a porta para a sua esquerda ou direita.

NOTA: Este producto se puede montar con la puerta a su izquierda o derecha.



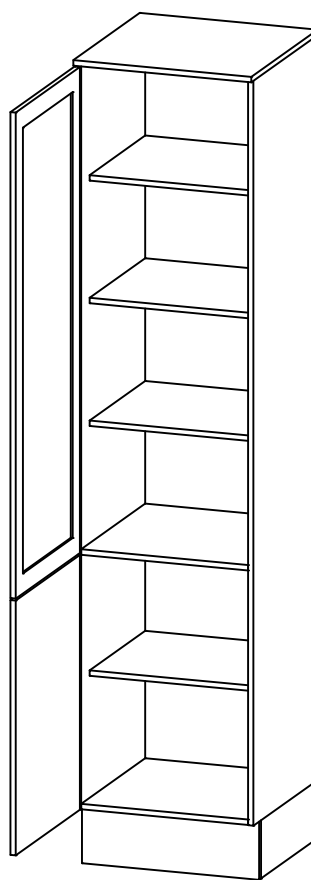
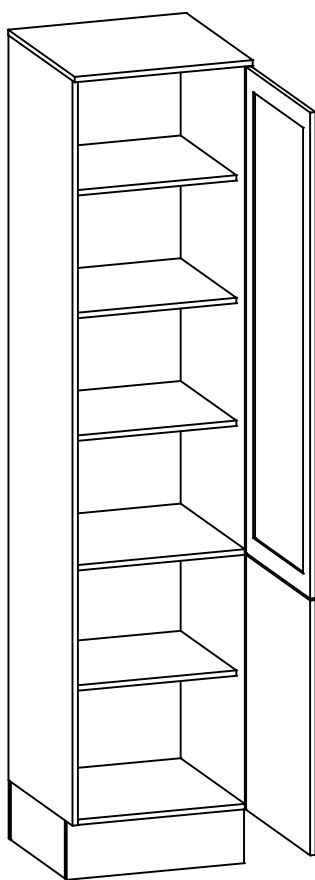





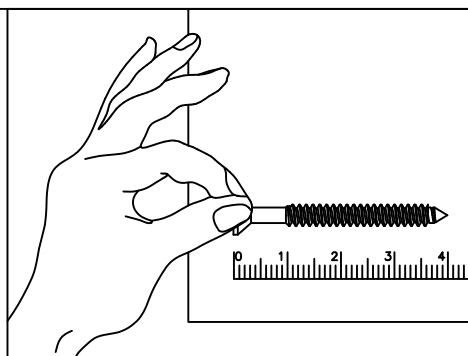

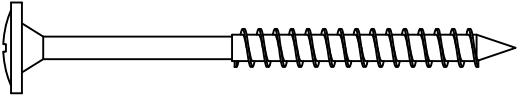
NOTE: This product can be mounted with the door to your left or right.

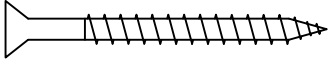

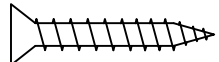
IDENTIFICAÇÃO DOS ACESSÓRIOS / IDENTIFICACIÓN DE ACCESORIOS / IDENTIFICATION OF ACCESSORIES

–NOTAS: A separação dos acessórios antes de iniciar a montagem facilitará a mesma.
–Nota: Separar los accesorios antes de iniciar el montaje facilitará el mismo.
–NOTE: Separating the accessories before starting assembly will make it easier.

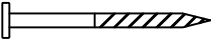
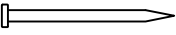

Ferragem / Herrajes / Hardware				
	Código/ Código/ Code	Descrição / Descripción / Description	Quan./ Cant./ Amou.	
PF9	50311	 	Parafuso flangeado/ Tornillo de cabeza flangead/ Flanged head screw 5,0x65mm	6
PC8	226	 	Parafuso chato/ Tornillo de cabeza plana/ Flat head screw 4x40mm	12
PC4	54117	 	Parafuso chato/ Tornillo de cabeza plana/ Flat head screw 3,5x25mm	6
PC3	4214	 	Parafuso chato/ Tornillo de cabeza plana/ Flat head screw 3,5x14mm	32
C1	1802		Cavilha/ Pin/ Wooden Dowel 6x30mm	20
PR2	108		Prego/Clavo/Nail 12x12	4
PR1	107		Prego/Clavo/Nail 10x10mm	51
BC	529		Bucha invasora/Adapter sleeve/ Manga del adaptador	6

Prezado Montador:

– Antes de iniciar a montagem verifique as condições do ambiente de montagem;
– Confira todas as peças das embalagens com a lista de peças contida neste manual;
– Separe os acessórios, confira as medidas dos parafusos com a escala;
– Siga todas as orientações deste manual de montagem para ter o direito à garantia do produto;
– Descarte as embalagens de forma correta, destinando o plástico e o papel para reciclagem;









Estimado Montador:

– Antes de iniciar a montagem verifique as condições do ambiente de montagem;
– Confira todas as peças das embalagens com a lista de peças contida neste manual;
– Separe os acessórios, confira as medidas dos parafusos com a escala;
– Siga todas as orientações deste manual de montagem para ter o direito à garantia do produto;
– Descarte as embalagens de forma correta, destinando o plástico e o papel para reciclagem;

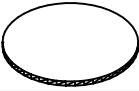
Dear Fitter:

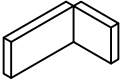
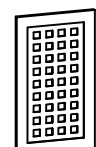
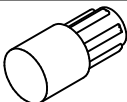

– Before starting mounting check as conditions of the assembly environment;
– Check out all the packaging com a list of fish contained in this manual;
– Separate the accessories, check the measures two parafusos com to scale;
– Follow all the guidelines of this manual mounting for ter or direct to guarantee of the product;
– Discard the packages correctly, allocating either plastic or paper for recycling;

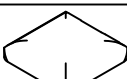
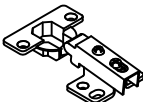
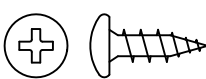

Ferragem / Herrajes / Hardware			
	Código/ Código/ Code	Descrição / Descripción / Description	Quan./ Cant./ Amou.
PX	63108	 Puxador/Asar/Handle	2
EM	58	 Etiqueta marca/Tag label "Kappesberg"	1
TP2	NGFE/NGVE=63102 (Nogueira)	 Tapa furo/Tapa del agujero/Screw cap cover 13mm	10
LM	85	 "L" de metal/Cantón "L" de metal/Metal angle bracket "L"	4
CG	899	 Cantoneira/Cantón /Angle bracket	4
S10	17024	 Suporte aéreo/Suporte de seguridad/Safety bracket	4
CS	6959	 Capa para suporte /Cubierta de soporte/Support cover	4
PO	NGFE/NGVE=63110	 Porta/ Puerta/ Door	1
S2	118	 Suporte para prateleira/Suporte de estante/Shelf support 6x8mm	24
SD	1901	 Sapata deslizadora preta/Zapata negra/Shoe black	4
GS	40534	 Silicone/Silicona/ Selecone	4
DO11	51322	 Dobradiça reta calço fixo e amortecedor/Bisangra/ Hinge 35mm	5
	61971	 Parafuso da dobradiça/ Tornillo del bisangra/Hinge Screw 4,0x14	30



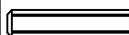

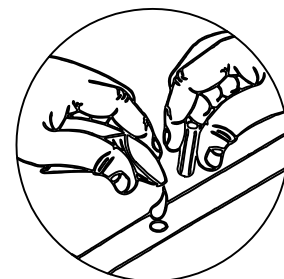
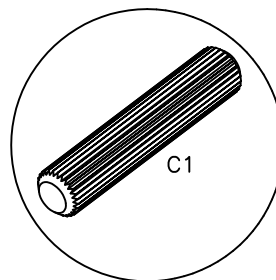
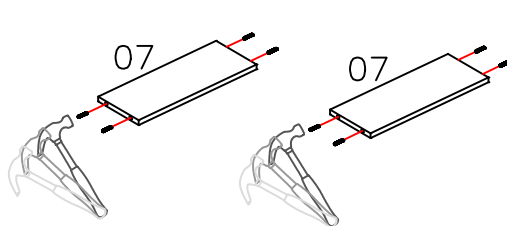
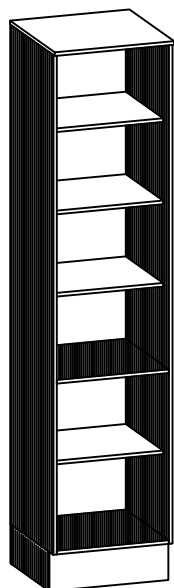
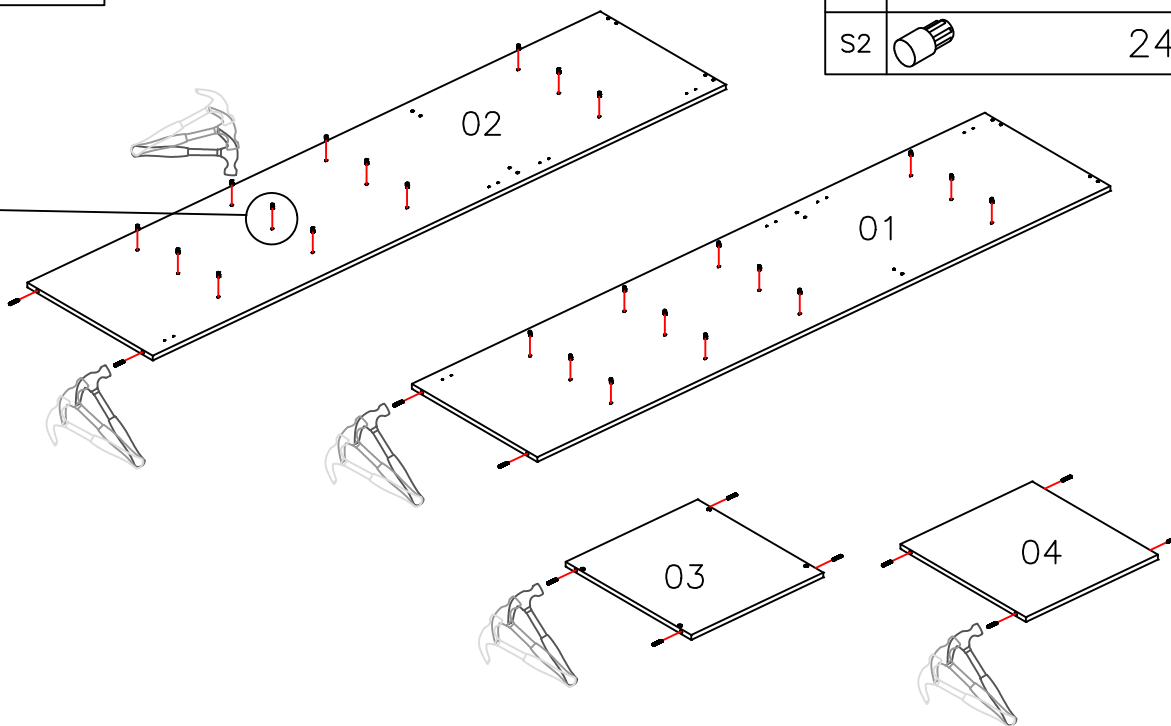
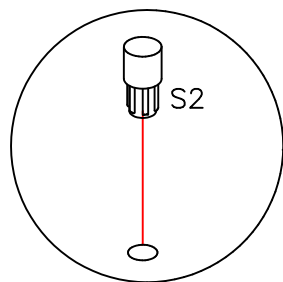

01 PASSO/ PASO/ STEP

C1		20
S2		24

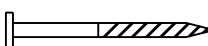

02 PASSO/ PASO/ STEP

PR2		4
SD		4
CG		4
PC3		8

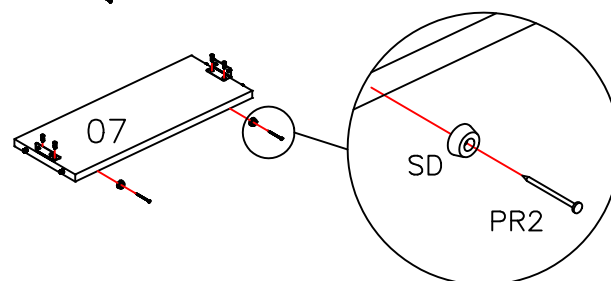
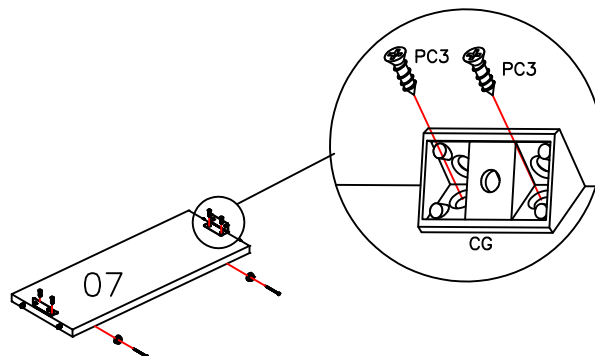
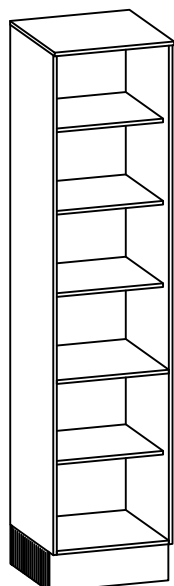

03 PASSO/ PASO/ STEP

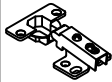
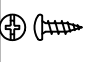

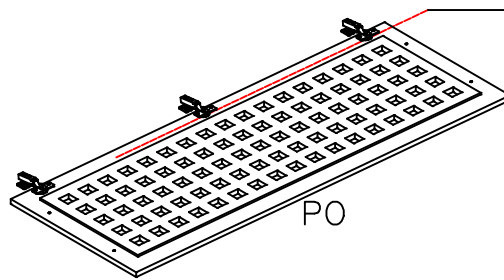
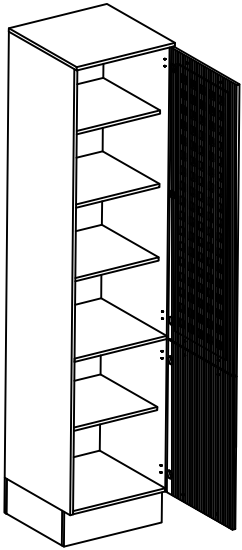
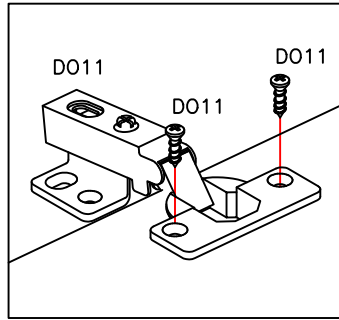
D011		5
D011		10



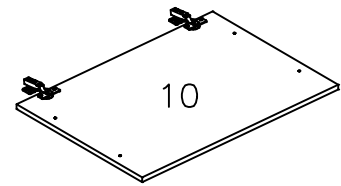

 -ATENÇÃO PARA O ALINHAMENTO DAS DOBRADIÇAS
 -ATENCIÓN PARA ALINEAR LAS BISAGRAS
 -ATTENTION TO THE ALIGNMENT OF THE HINGES

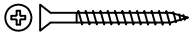

04 PASSO/ PASO/ STEP

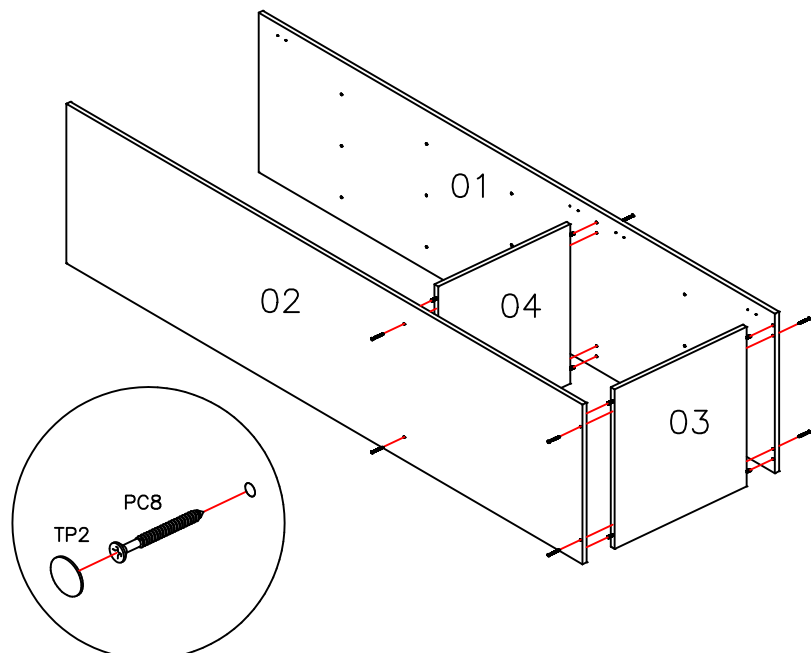
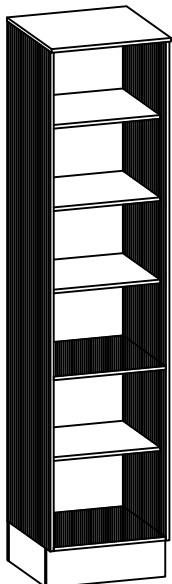
PC8		8
TP2		8

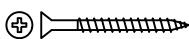

05 PASSO/ PASO/ STEP

PC8		4
-----	---	---

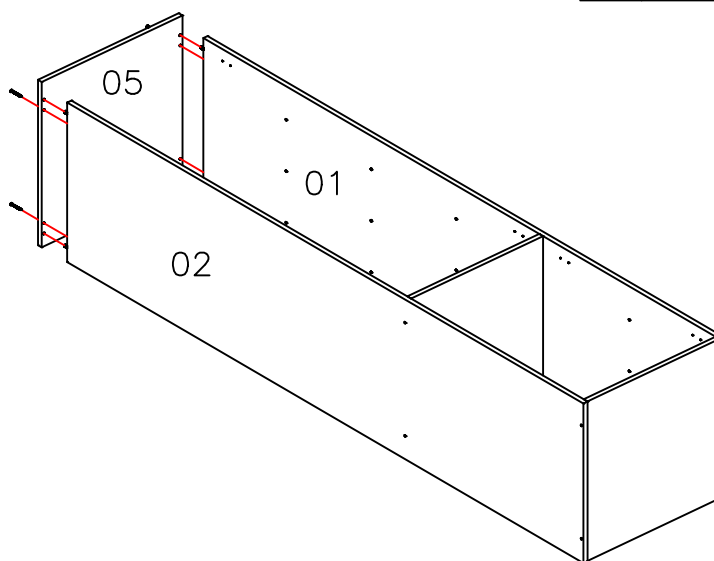
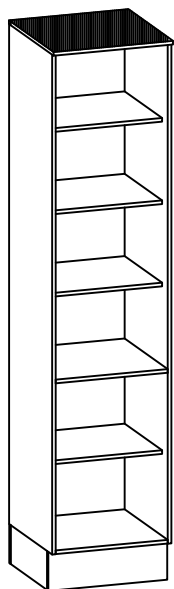

06 PASSO/ PASO/ STEP

PC3		8
-----	---	---

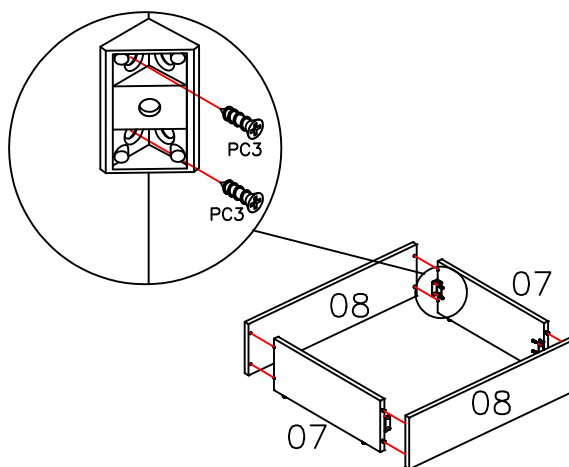
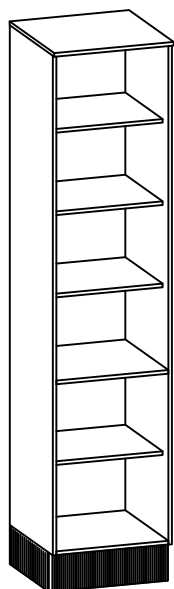

07 PASSO/ PASO/ STEP

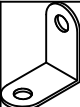
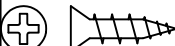
LM		4
PC3		8

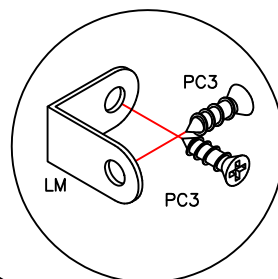
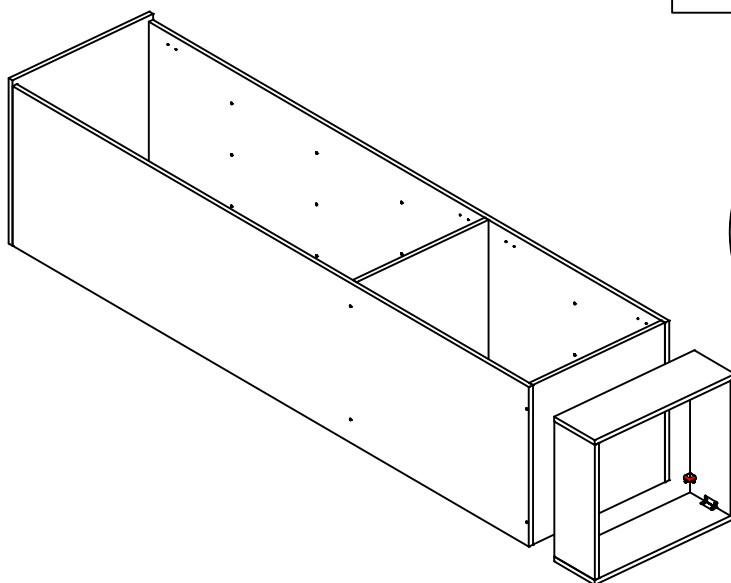
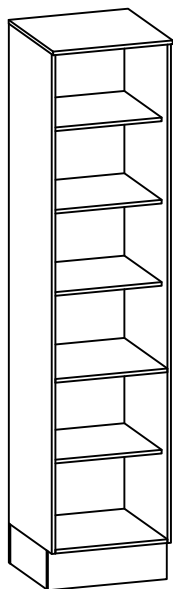

08 PASSO/ PASO/ STEP

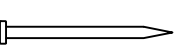
PR1		51
-----	---	----

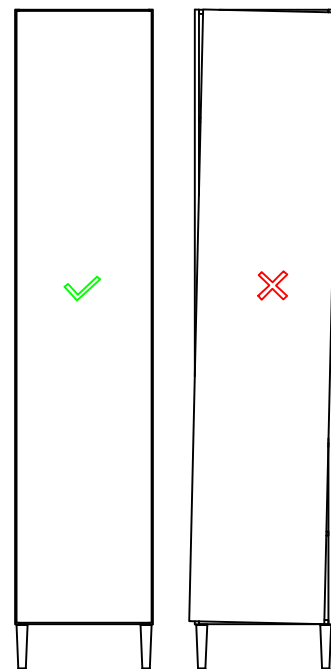
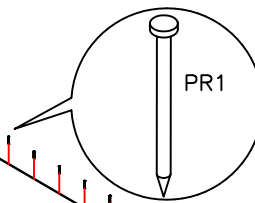
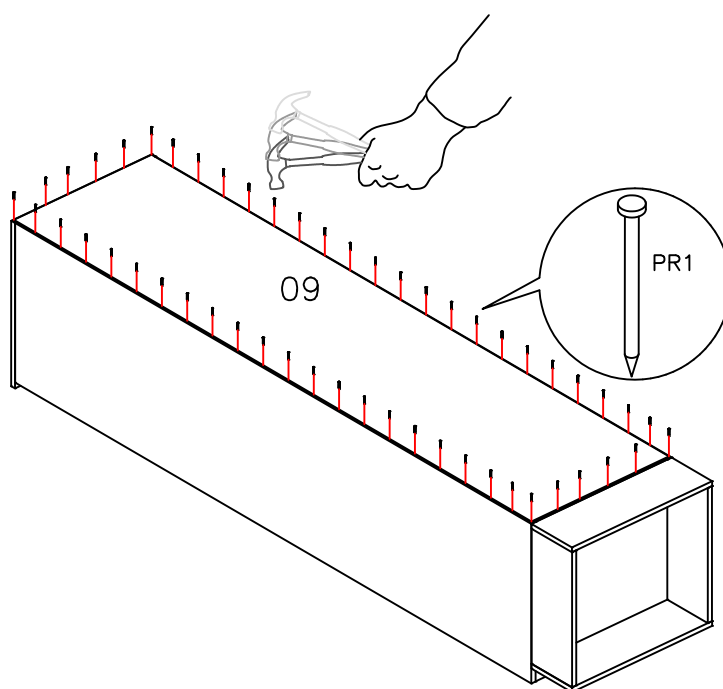
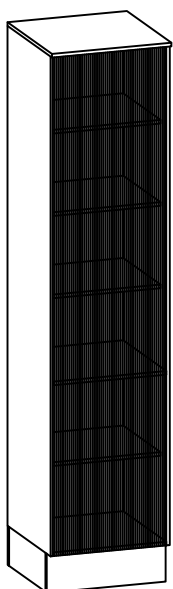

09 PASSO/ PASO/ STEP

NOTA: Nessa versão, foi optado por indicar a dobradiça para o lado direito. Caso haja a necessidade de montar para o lado esquerdo, utilize as marcações contidas na lateral.

NOTAS: En esta versión, se eligió indicar la bisagra en el lado derecho. Si es necesario montarlo en el lado izquierdo, use las marcas en el costado.

NOTE: In this version, it was chosen to indicate the hinge to the right side. If there is a need to mount to the left side, use the markings on the side.

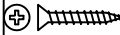
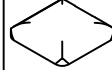
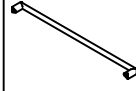
PP1		20
PC4		4
GS		4
PX		2

NOTA: Utilize o furo oblongo para posicionar a altura da dobradiça. E por fim quando a porta estiver posicionada de maneira correta utilize o furo circular para garantir que a mesma não se desloque.

NOTAS: Utilice o furo oblongo para posicionar a altura da dobradiça. E por fim quando a porta estiver posicionada de maneira correta utiliza o furo circular para garantir que a mesma não se desloque.

NOTE: Use the oblong edge to position at the height of the dobradiça. And for this reason, when the estiver holder is positioned in a correct way, use a circular hole to ensure that it does not loosen at the same time.

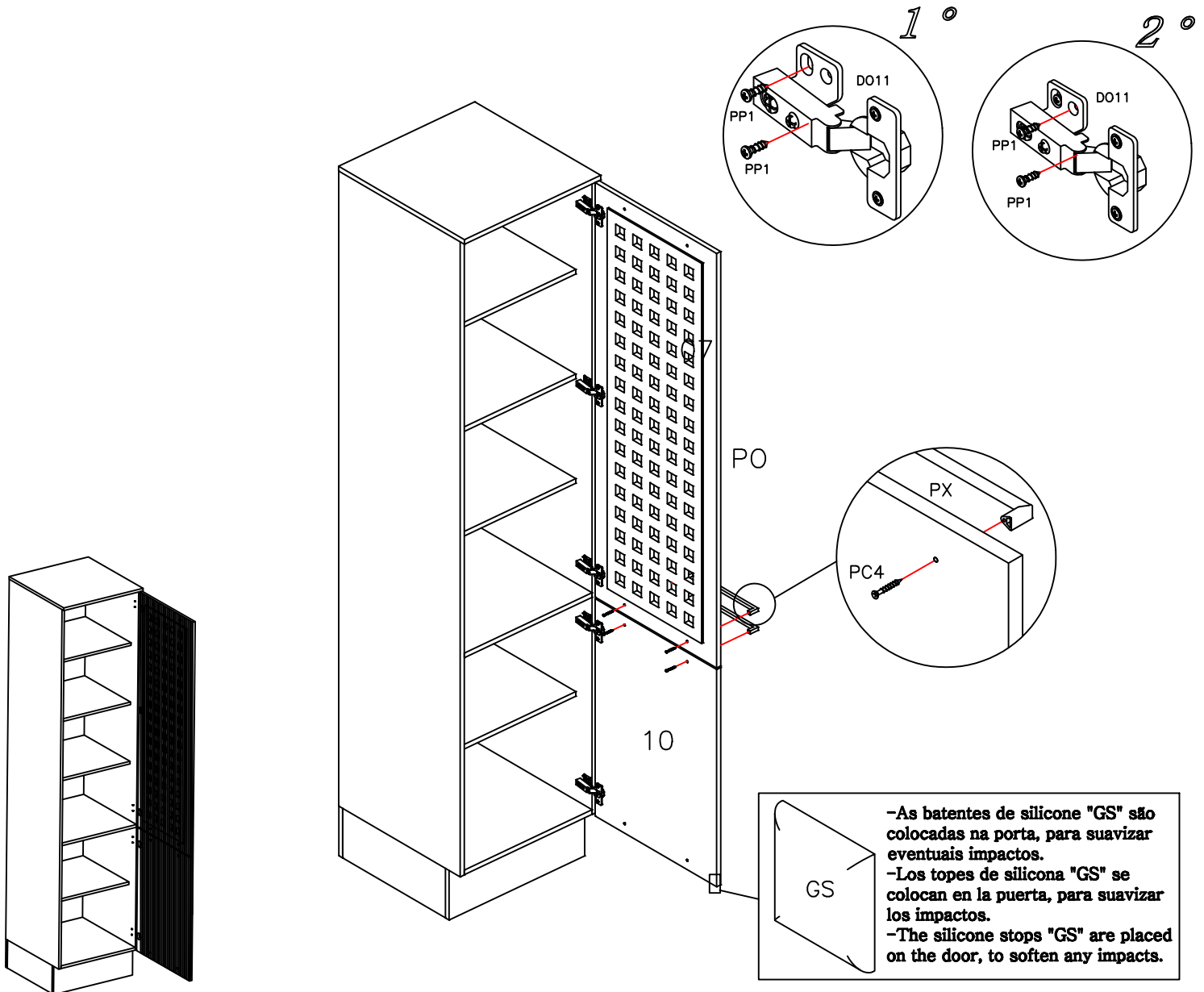

-As batentes de silicone "GS" são colocadas na porta, para suavizar eventuais impactos.
-Los topos de silicona "GS" se colocan en la puerta, para suavizar los impactos.
-The silicone stops "GS" are placed on the door, to soften any impacts.

10 AJUSTE DE PORTAS / AJUSTE DE PUERTA / DOORS ADJUSTMENT

REGULAGEM VERTICAL / AJUSTE VERTICAL / VERTICAL ADJUSTMENT

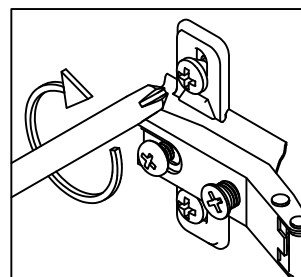
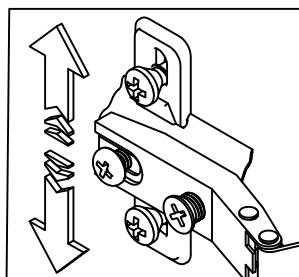
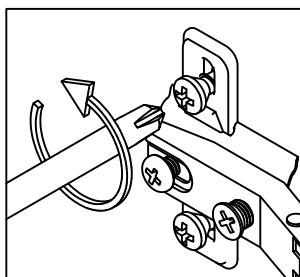
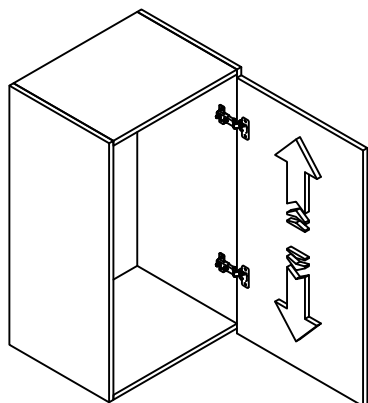

REGULAGEM PROFUNDIDADE / AJUSTE PROFUNDIDAD / DEPTH ADJUSTMENT

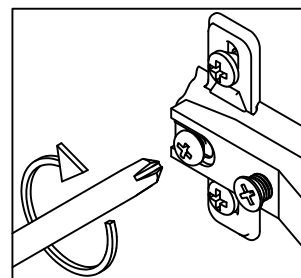
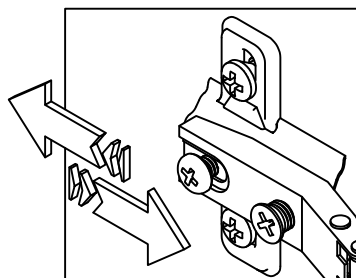
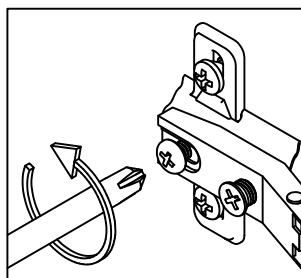
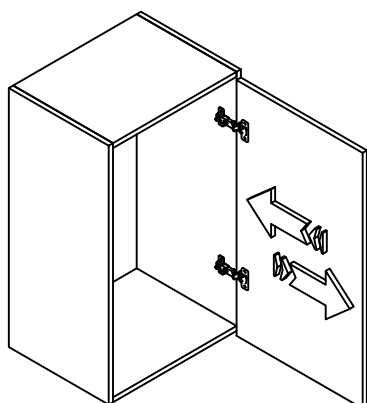

REGULAGEM HORIZONTAL / AJUSTE HORIZONTAL / HORIZONTAL ADJUSTMENT

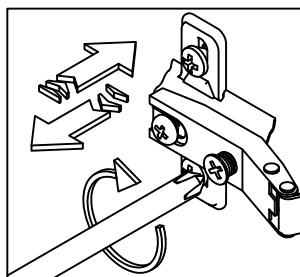
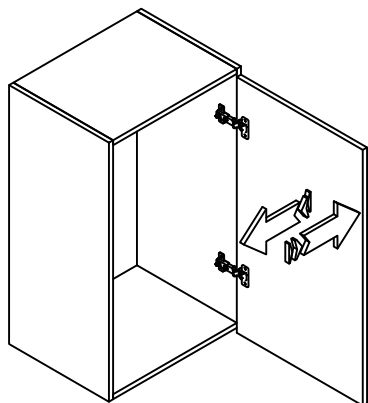

11 PASSO/ PASO/ STEP

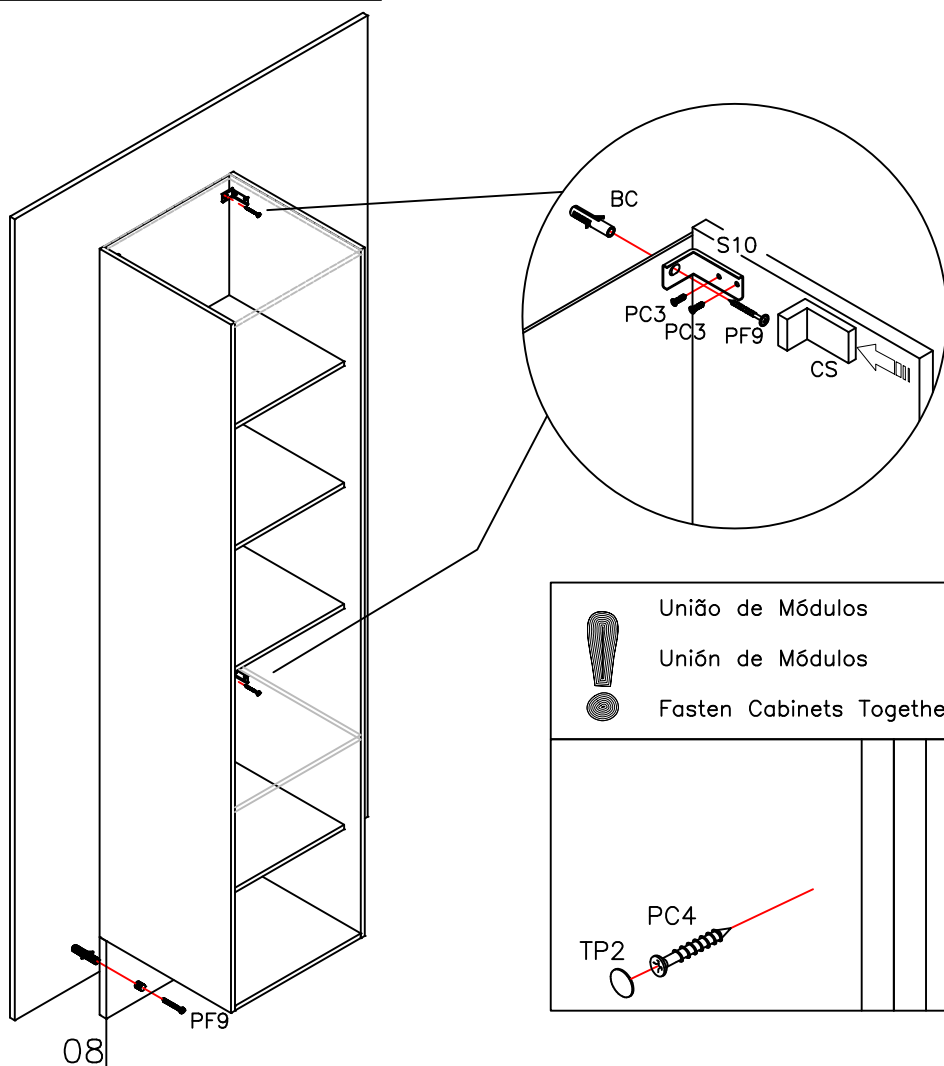

PC3		8
PC4		2
PF9		6
S10		4
CS		4
BC		6
TP2		2

Para montar a cozinha suspensa:

- Utilize o rodapé "08" que acompanha o móvel como apoio para sua fixação na parede, utilizando a bucha "BC" e o parafuso "PF9".
- Em cada lateral fixe um suporte aéreo metalizado "S10" com o parafuso "PC3" e na parede com o parafuso "PF9" e com a bucha "BC".
- Coloque uma capa "CS" em cada suporte "S10".

Para montar la cocina suspendida:

- Utilizar el rodapié frontal "08" que viene con el mueble como soporte para fijarlo a la pared, mediante el casquillo "BC" y el tornillo "PF9".
- En cada lado, fijar un soporte aéreo metalizado "S10" con el tornillo "PC3" y en la pared con el tornillo "PF9" y con el casquillo "BC".
- Colocar una funda "CS" en cada soporte "S10".

To assemble the suspended kitchen:

- Use the front baseboard "08" that comes with the furniture as a support for fixing it on the wall, using the "BC" bushing and the "PF9" screw.
- On each side, fix a metalized aerial support "S10" with the screw "PC3" and on the wall with the screw "PF9" and the bushing "BC".
- Place a cover "CS" on each support "S10".

A montagem deve ser efetuada por UMA pessoa.
El montaje debe ser efectuado por UNA persona.
The assembly must be done by ONE people.

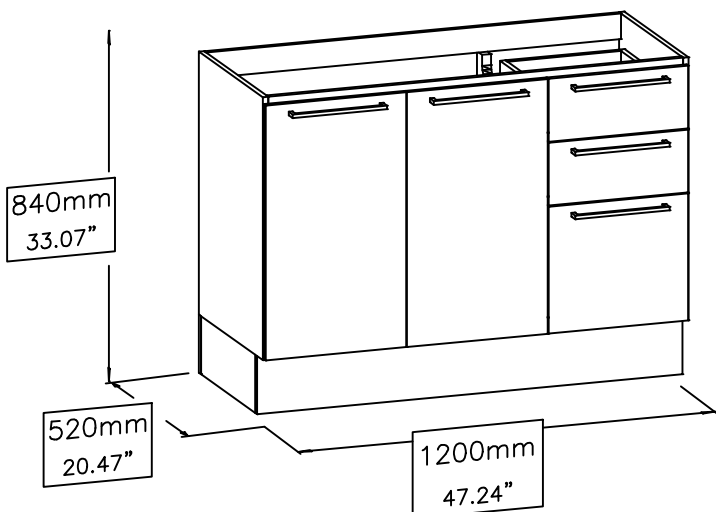

Ferramentas necessárias para montar o móvel
Herramientas necesarias para armar el mueble.
Tools needed to assemble the furniture.

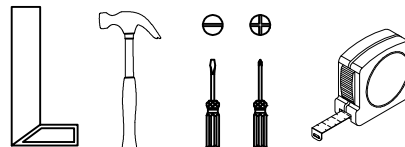

Montar o móvel sobre uma superfície limpa e plana

Armar el mueble sobre una superficie limpia y plana

Assemble the furniture on a clean and flat surface

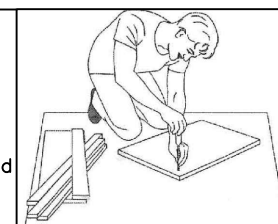

Lista de peças / Lista de piezas / List of pieces

Código / Code	Descrição	Descripción	Description	Quantidade / Cantidad / Amount	Comprimento / Longitud / Length (mm)	Comprimento / Longitud / Length (in.)	Largura / Ancho / Width (mm)	Largura / Ancho / Width (in.)	Espessura / Espesor / Thickness (mm)	Espessura / Espesor / Thickness (in.)	Caixa / Caja / Box
01	Lateral direita	Lateral derecha	Right side	1	720	28.35"	496	19.53"	15	.59"	A
02	Lateral esquerda	Lateral izquierda	Left side	1	720	28.35"	496	19.53"	15	.59"	A
03	Base	Pieza de suelo	Bottom/Base	1	1168	45.98"	496	19.53"	15	.59"	A
04	Prateleira	Estantería	Shelf	1	768	30.24"	430	16.93"	15	.59"	A
05	Travessas	Travesaño	Crosspiece	2	1168	45.98"	70	2.76"	15	.59"	A
06	Rodapé lateral	Falda lateral	Side Skirting	2	420	16.54"	160	6.30"	15	.59"	A
07	Rodapé	Zócalo	Baseboard	2	1197	47.13"	160	6.30"	15	.59"	A
08	Lateral de gaveta dir.	Lateral de cajón derecha	Right drawer side	2	420	16.54"	100	3.94"	15	.59"	A
09	Lateral de gaveta esq.	Lateral de cajón izquierda	Left drawer side	2	420	16.54"	100	3.94"	15	.59"	A
10	Cabeceira de gaveta	Cabecera de cajón	Back drawer	2	320	12.60"	100	3.94"	15	.59"	A
11	Lateral de gavetão dir.	Lateral de cajón derecha	Right Side of Drawer – Largest	1	420	16.54"	180	7.09"	15	.59"	A
12	Lateral de gavetão esq.	Lateral de cajón izquierda	Left Side of Drawer – Largest	1	420	16.54"	180	7.09"	15	.59"	A
13	Cabeceira de gavetão	Cabecera de cajón mayor	Back of Drawer – Largest	1	320	12.60"	180	7.09"	15	.59"	A
14	Divisória	División	Division	1	634	24.96"	496	19.53"	25	.98"	A
15	Costa maior	Pieza mayor del fondo	Bottom larger	2	793	31.22"	335	13.19"	3	.12"	A
16	Costas das gavetas	Piezas de fondo de los cajones	Bottom parts of the drawers	1	675	26.57"	397	15.63"	3	.12"	A
17	Fundo de gaveta	Fondo de cajón	Bottom drawer	3	333	13.11"	418	16.46"	3	.12"	A
18	Portas	Puertas	Doors	2	698	27.48"	396	15.59"	3	.12"	A
19	Frente de gavetão	Frente de cajón mayor	Largest drawer front	1	393	15.47"	348	13.70"	15	.59"	A
20	Frente de gaveta	Frente de cajón	Front drawer	2	393	15.47"	172	6.77"	15	.59"	A

IDENTIFICAÇÃO DAS PEÇAS/ IDENTIFICACIÓN DE LAS PIEZAS/ PARTS IDENTIFICATION

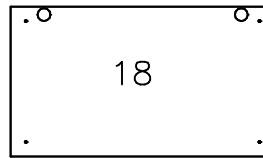
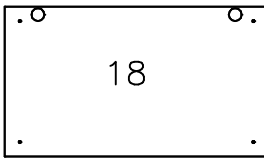
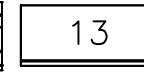
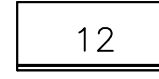
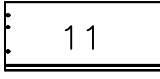
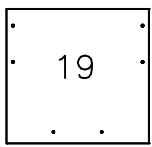
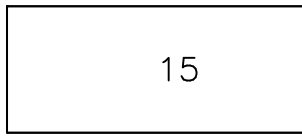
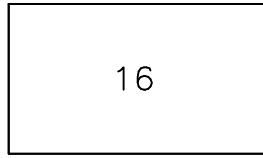
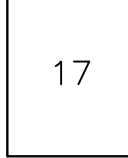
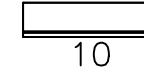
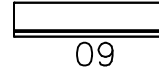
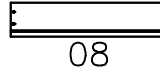
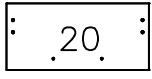
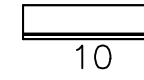
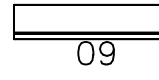
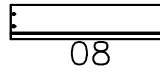
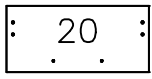
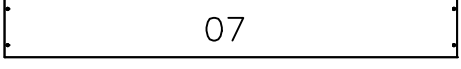
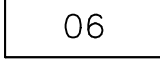
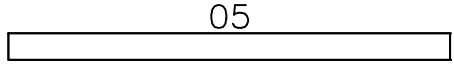
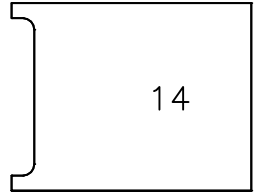
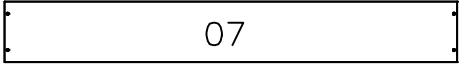
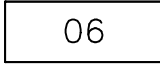
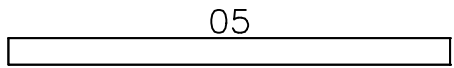
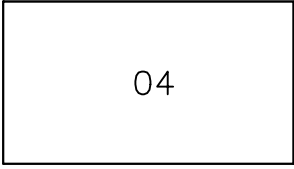
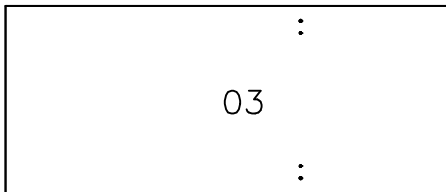
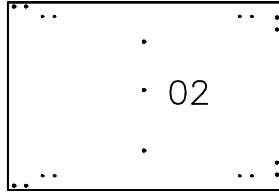
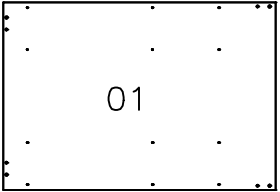

Duvidas? entrar em contato:
¿Dudas? Ponerse en contacto:
Doubts? Get in touch:

Fone: (51) 3635-8839
www.kappesberg.com.br

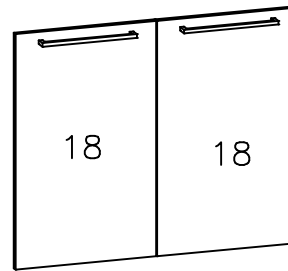
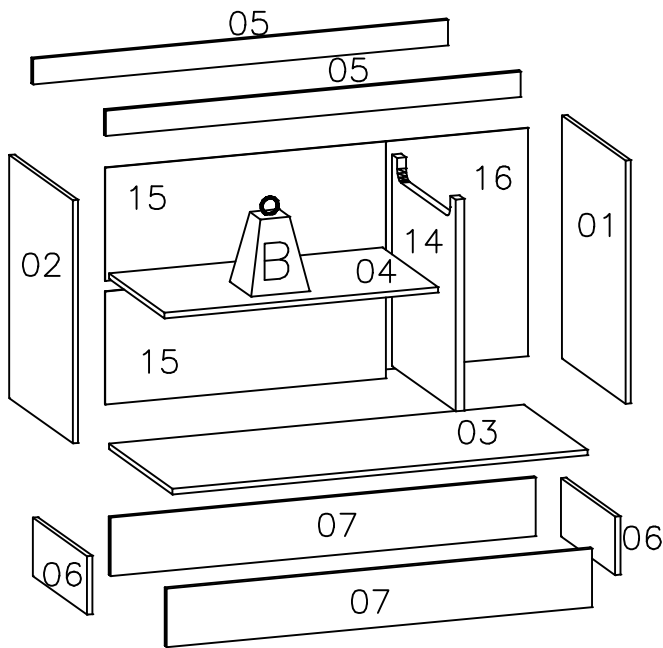
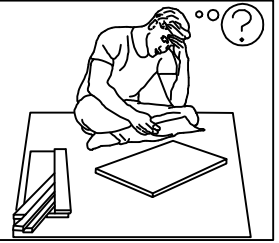

	Kg	lb
A	6	13.23lb
B	7	15.43lb

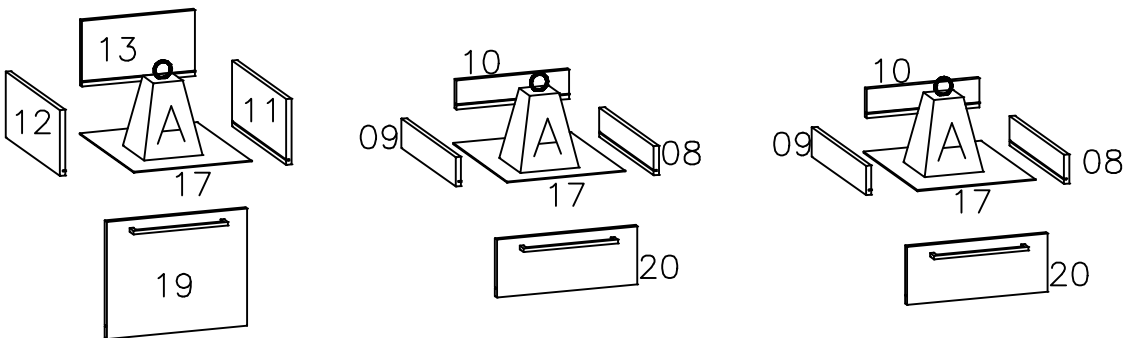

NOTE: Este produto pode ser montado com as gavetas para a sua esquerda ou direita.
NOTA: Este producto se puede montar con los cajones a su izquierda o derecha.
NOTE: This product can be mounted with the drawers to your left or right.

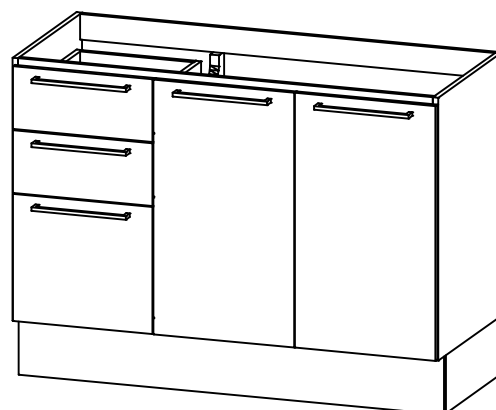
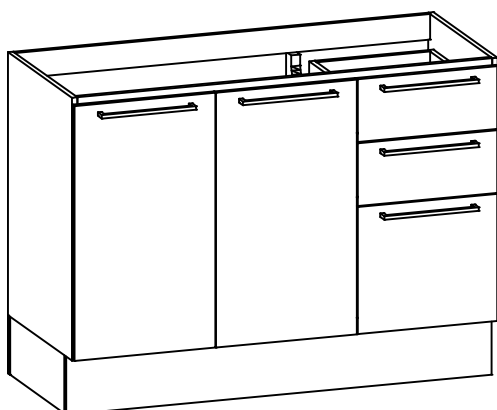

IDENTIFICAÇÃO DOS ACESSÓRIOS / IDENTIFICACIÓN DE ACCESORIOS / IDENTIFICATION OF ACCESSORIES







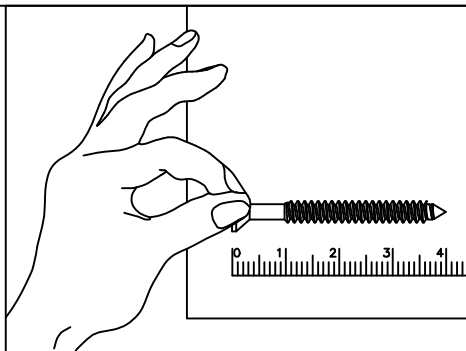



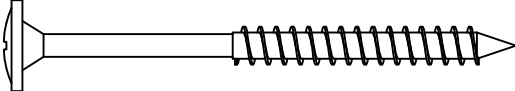

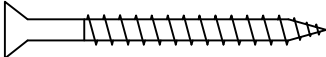
–NOTAS: A separação dos acessórios antes de iniciar a montagem facilitará a mesma. Os parafusos e cavilhas estão na escala real. Em caso de dúvida na identificação, coloque o acessório sobre a imagem.

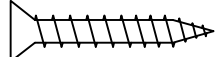
–NOTAS:La separación de los accesorios antes de comenzar el armado facilitará el mismo. Los tornillos y taquetes son en escala real. En caso de dudas sobre la identificación, coloque el accesorio en la imagen.

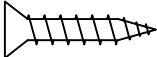
–NOTES:The separation of the accessories before you start the assembly will facilitate the same. The screws and dowels are in real scale. In case of doubts about the identification, place the accessory on the image

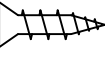

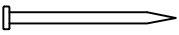
Ferragem / Herrajes / Hardware

	Código/ Código/ Code	Descrição / Descripción / Description	Quan./ Cant./ Amou.
PF9	50311	  Parafuso flangeado/ Tornillo de cabeza flangead/ Flanged head screw 5,0x65mm	5
PC8	226	  Parafuso chato/ Tornillo de cabeza plana/ Flat head screw 4x40mm	20
PC4	54117	  Parafuso chato/ Tornillo de cabeza plana/ Flat head screw 3,5x25mm	12
PC5	5256	  Parafuso/ Tornillo/ Screw 4X20	6
PC3	4214	  Parafuso chato/ Tornillo de cabeza plana/ Flat head screw 3,5x14mm	135
C1	1802	 Cavilha/ Pin/ Wooden Dowel 6x30mm	40
PR2	108	 Prego/Clavo/Nail 12x12	6
PR1	107	 Prego/Clavo/Nail 10x10mm	32
BC	529	 Bucha invasora/Adapter sleeve/ Manga del adaptador	5
CB	41	 Cola branca em bisnaga/Cola blanca/White glue	2

Prezado Montador:

– Antes de iniciar a montagem verifique as condições do ambiente de montagem;
– Confira todas as peças das embalagens com a lista de peças contida neste manual;
– Separe os acessórios, confira as medidas dos parafusos com a escala;
– Siga todas as orientações deste manual de montagem para ter o direito à garantia do produto;
– Descarte as embalagens de forma correta, destinando o plástico e o papel para reciclagem;











Estimado Montador:

– Antes de iniciar a montagem verifique as condições do ambiente de montagem;
– Confira todas como peças das embalagens com una lista de peças contida neste manual;
– Separe os acessórios, confira as medidas dos parafusos com a escala;
– Siga todas las orientaciones deste manual de montaje para ter o derecho à garantía do producto;
– Descarte como embalagens de forma correcta, destinando o plástico e o papel para reciclagem;

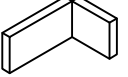
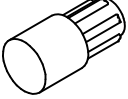
Dear Fitter:

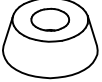
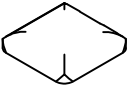
– Before starting montage check as conditions of the assembly environment;
– Check out all the packaging com a list of fish contained in this manual;
– Separate the accessories, check the measures two parafusos com to scale;
– Follow all the guidelines of this manual montage for ter or direct to guarantee of the product;
– Discard the packages correctly, allocating either plastic or paper for recycling;

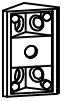
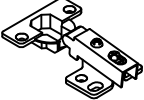
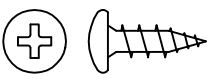

Ferragem / Herrajes / Hardware			
	Código/ Código/ Code	Descrição / Descripción / Description	Quan./ Cant./ Amou.
PX	63108	 Puxador/Asar/Handle	5
EM	58	 Etiqueta marca/Tag label "Kappesberg"	1
TP2	NGFE/NGVE=63102 (Nogueira)	 Tapa furo/Tapa del agujero/Screw cap cover 13mm	12
LM	85	 "L" de metal/Cantón "L" de metal/Metal angle bracket "L"	16
S10	17024	 Suporte aéreo/Soporte de seguridad/Safety bracket	3
CS	6959	 Capa para suporte /Cubierta de soporte/Support cover	3
S2	118	 Suporte para prateleira/Soporte de estante/Shelf support 6x8mm	6
S5	18458	 Suporte triangular preto/Soporte triangular negro/Black triangular support	6
FC	1423	 Fixador de costa/Fijador de costa/Shore Fixer	8
SD	1901	 Sapata deslizadora preta/Zapata negra/Shoe black	6
GS	40534	 Silicone/Silicona/ Selecone	4
PH	NGFE/NGVE= 26076 (Carvalle)	 Perfil H/Perfil de acabado/Finishing profile	1
CG	899	 Cantoneira/Cantón /Angle bracket	12
D011	51322	 Dobradiça reta calço fixo e amortecedor/Bisagra/ Hinge 35mm	4
	61971	 Parafuso da dobradiça/ Tornillo del bisagra/Hinge Screw 4,0x14	24
TT14	64831	 Trilho telescópico light/Corredera de metal/Metal slide 350mm	3
TT14A		Instalação nos painéis/ deslizante sobre paneles/Sliding installation on panels	
TT14B		Corrediça da gaveta/Drawer slide/Corredera de cajón	



1A PASSO/ PASO/ STEP

C1		8
----	---	---

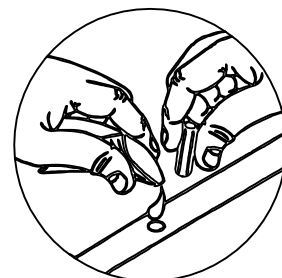
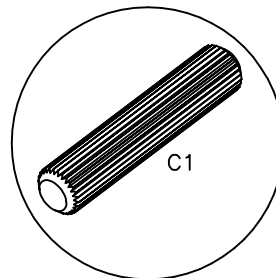
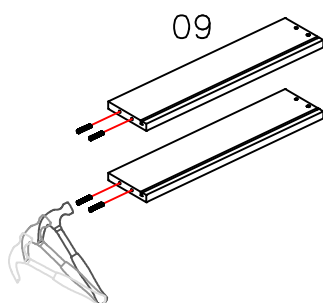
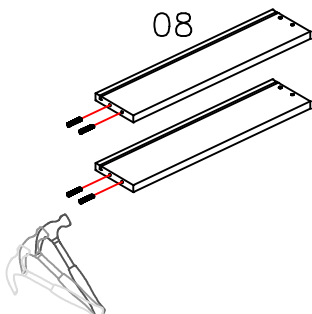

1B PASSO/ PASO/ STEP

C1		4
----	---	---

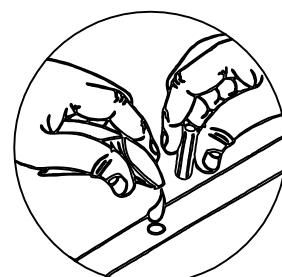
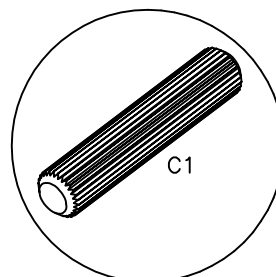
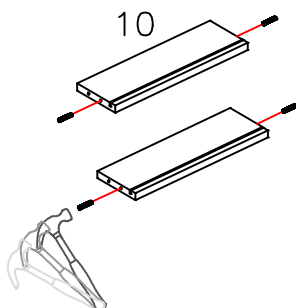

1C PASSO/ PASO/ STEP

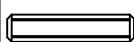
C1		4
----	---	---

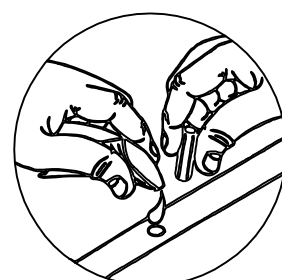
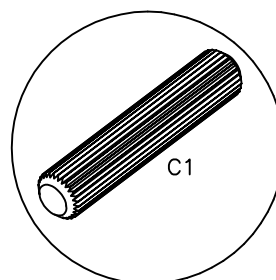
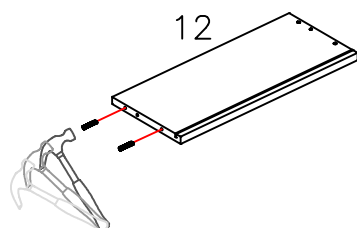
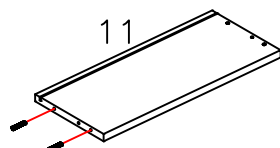

1D PASSO/ PASO/ STEP

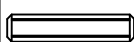
C1		4
----	---	---

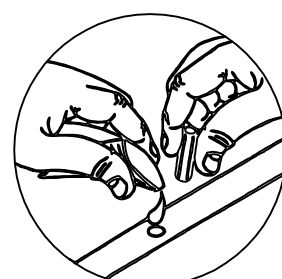
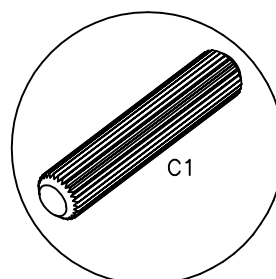
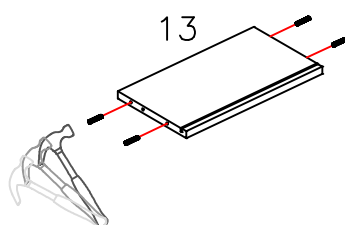

02 PASSO/ PASO/ STEP

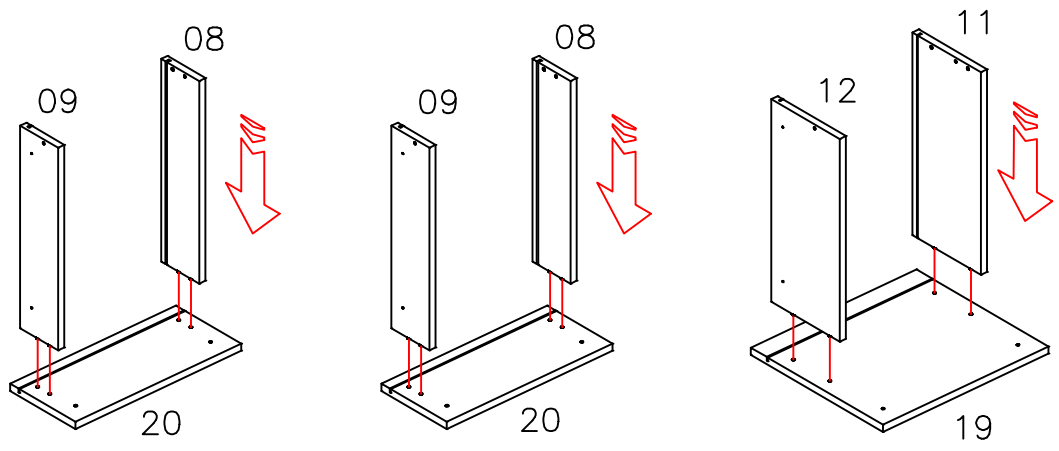

03 PASSO/ PASO/ STEP

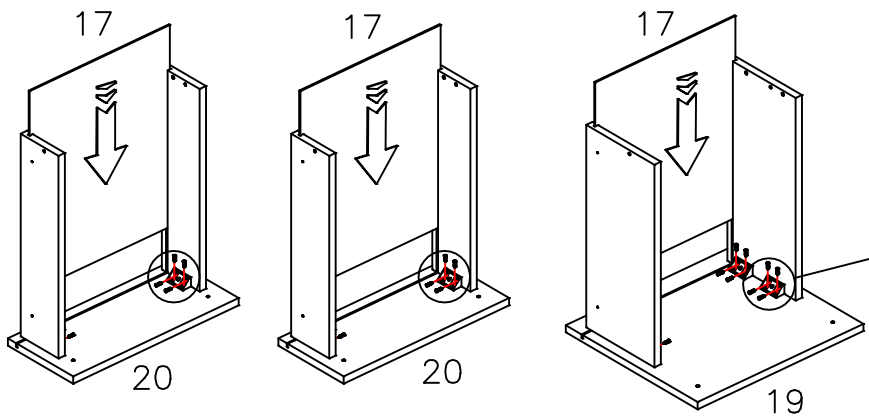



CG		8
PC3		32

04 PASSO/ PASO/ STEP

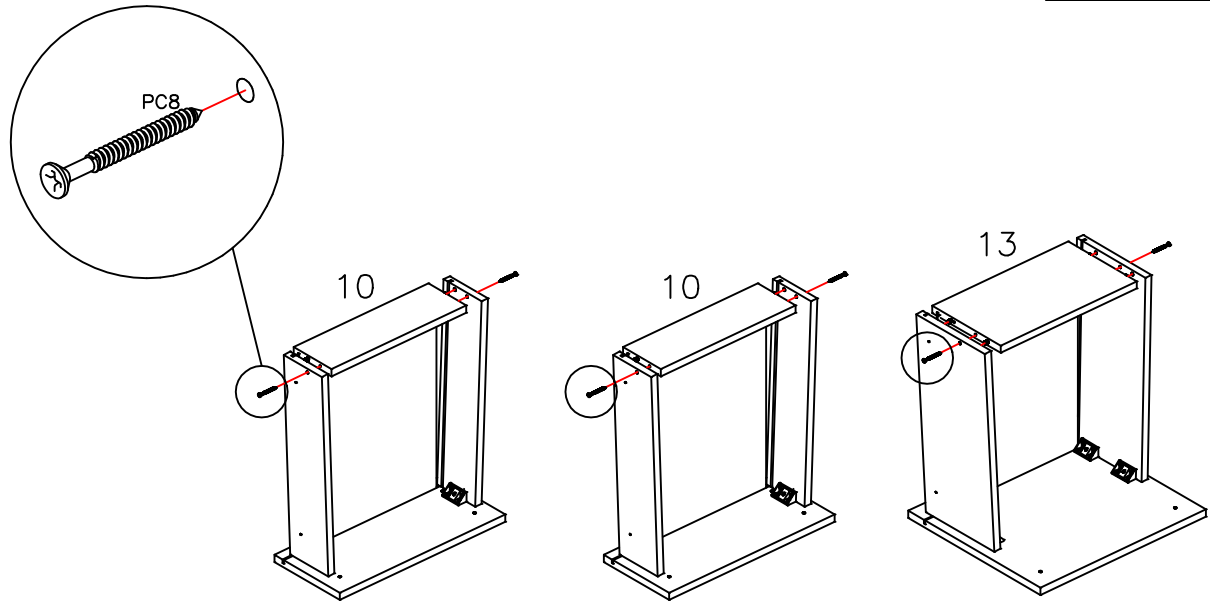
PC8		6
-----	--	---



05 PASSO/ PASO/ STEP

TT14B		6
PC3		18

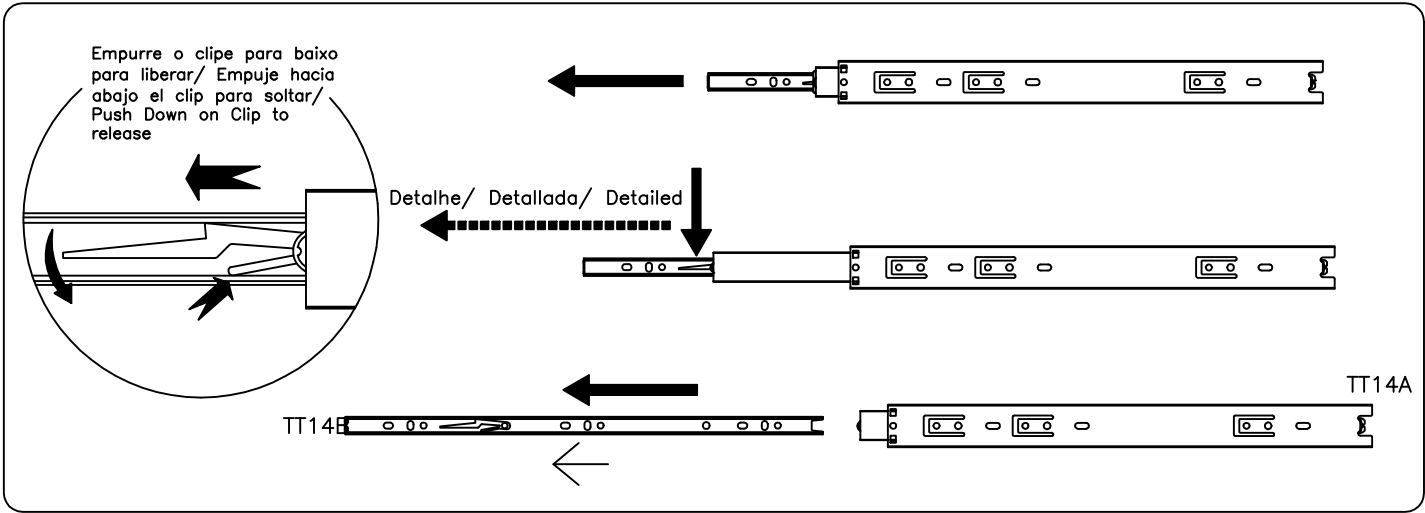

Frente
Delantera
Front

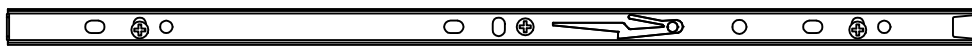

Atrás
Espalda
Back

↑ 1° 1ST

↑ 3° 3RD

↑ 2° 2ND



1° / 1ST



2° / 2ND



3° / 3RD

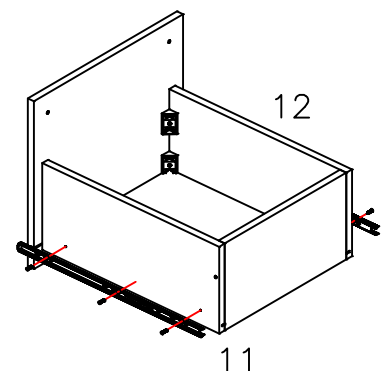
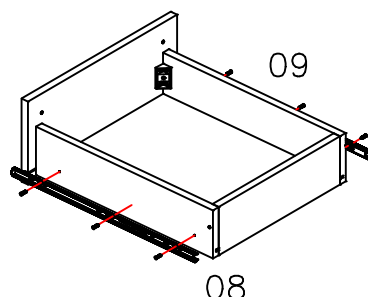
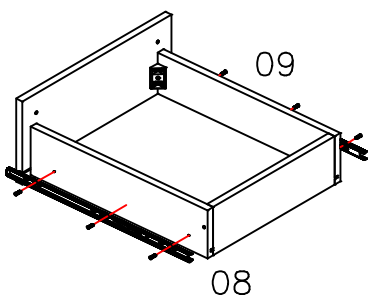
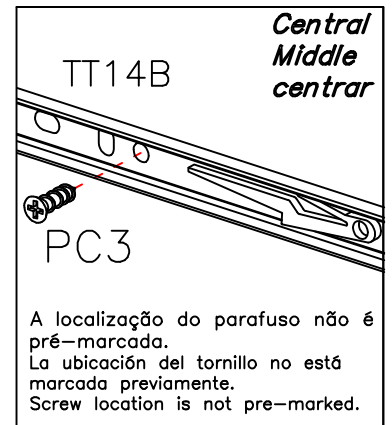
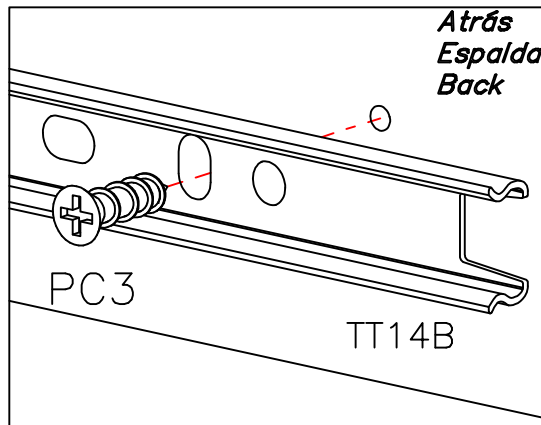
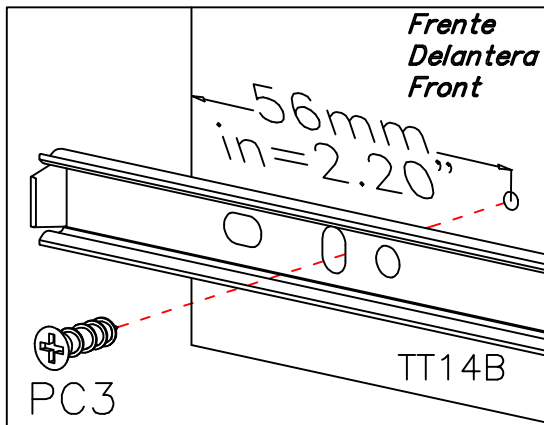

06 PASSO/ PASO/ STEP

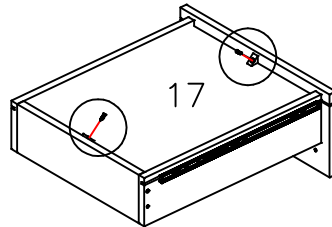
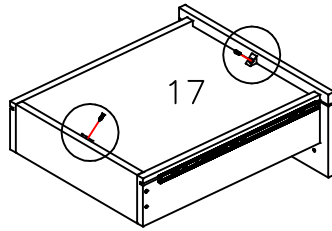
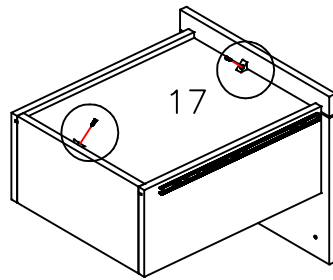

PC5		6
S5		6

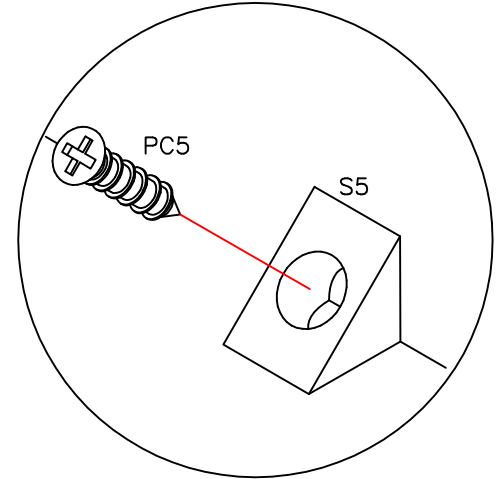

07 PASSO/ PASO/ STEP

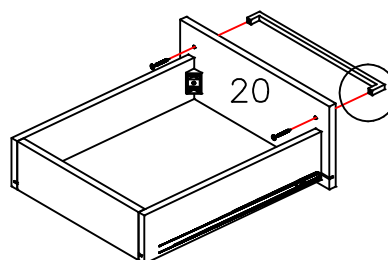
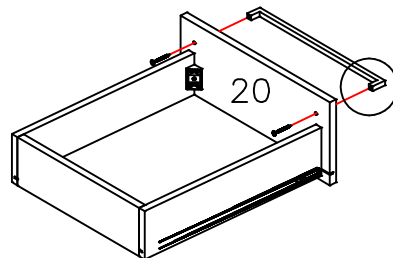
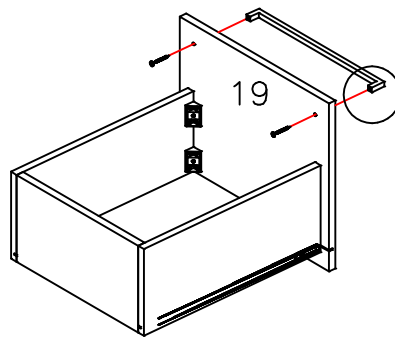

PC4		6
PX		3

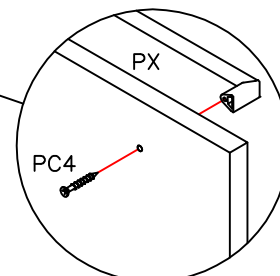

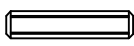

08 PASSO/ PASO/ STEP

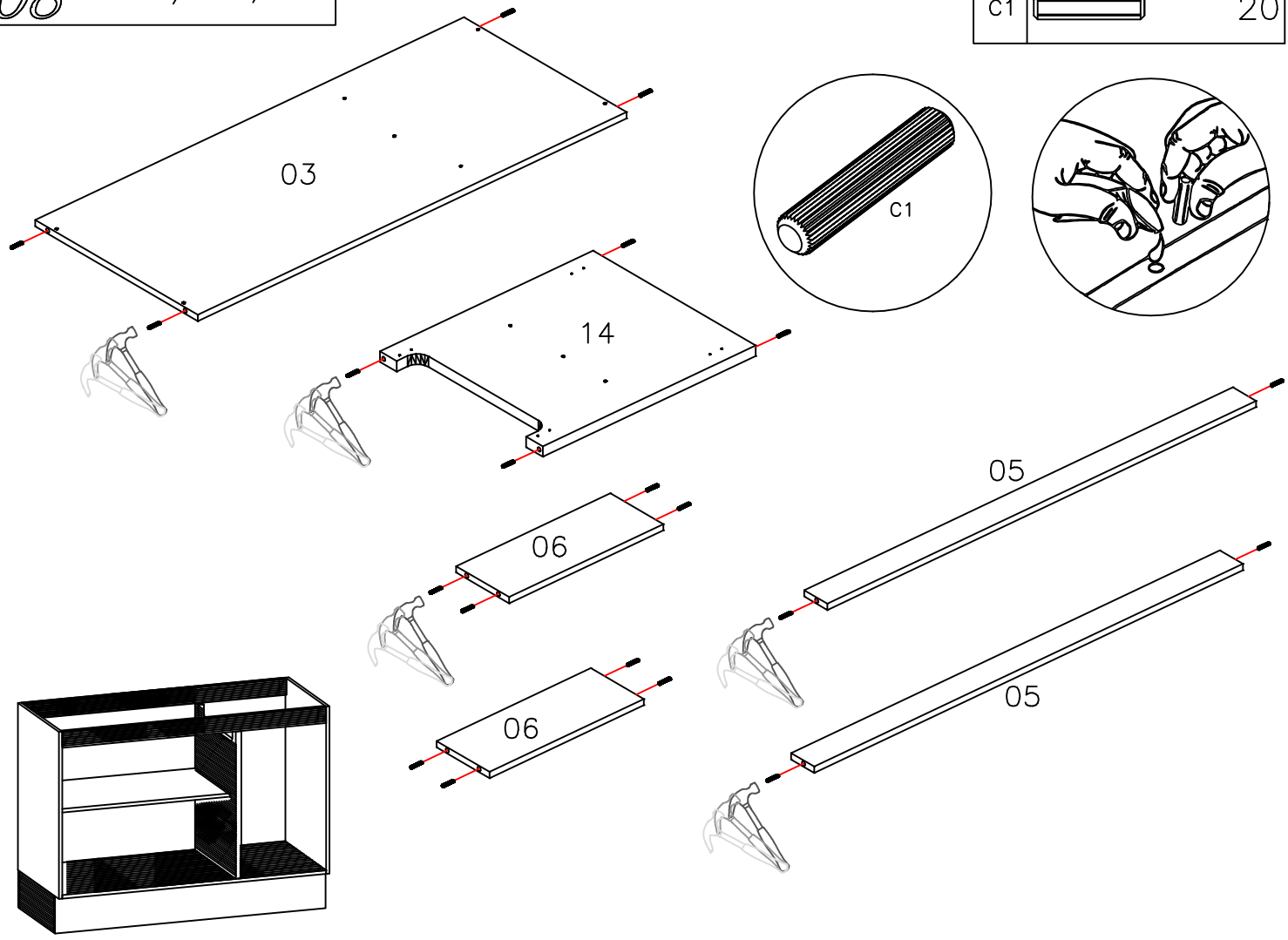
C1		20
----	---	----

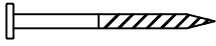
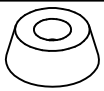

09 PASSO/ PASO/ STEP

PR2		6
SD		6
CG		4
PC3		8

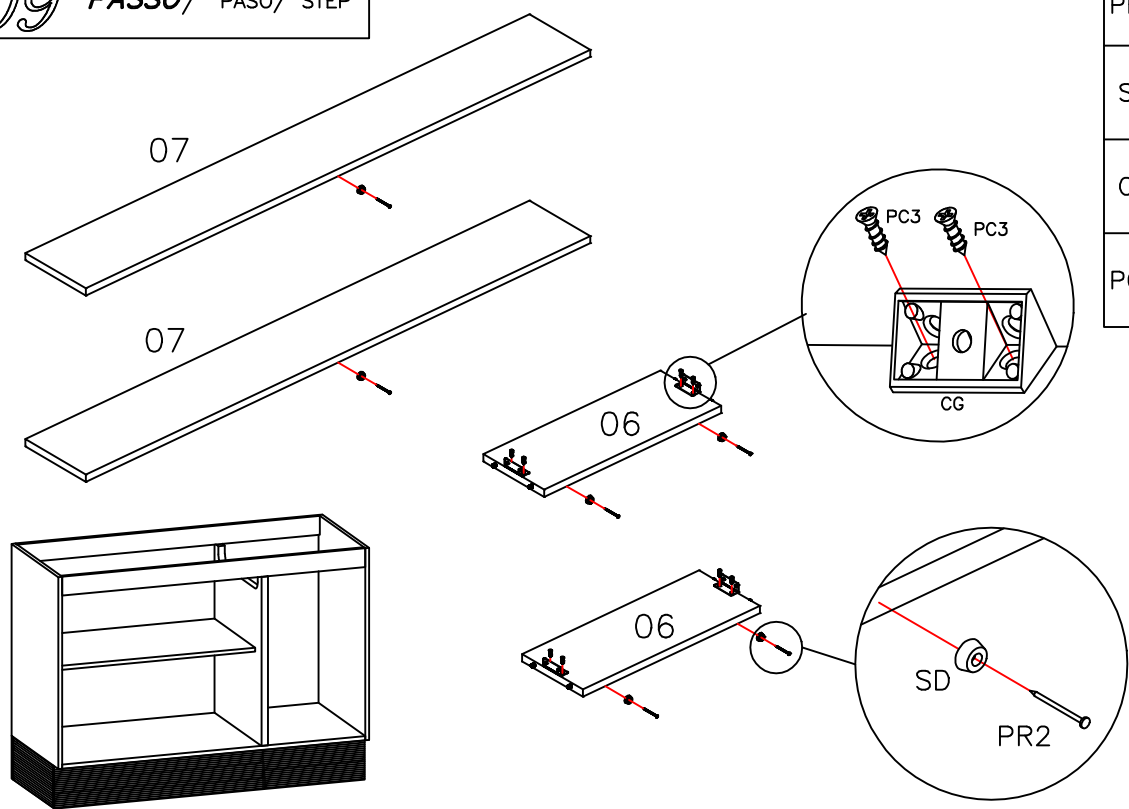

10 PASSO/ PASO/ STEP

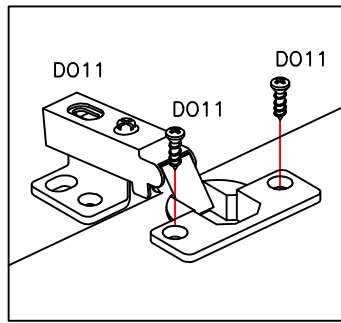

D011		4
D011		8



-ATENÇÃO PARA O ALINHAMENTO DAS DOBRADIÇAS
-ATENCIÓN PARA ALINEAR LAS BISAGRAS
-ATTENTION TO THE ALIGNMENT OF THE HINGES

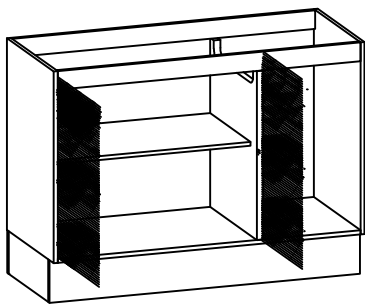
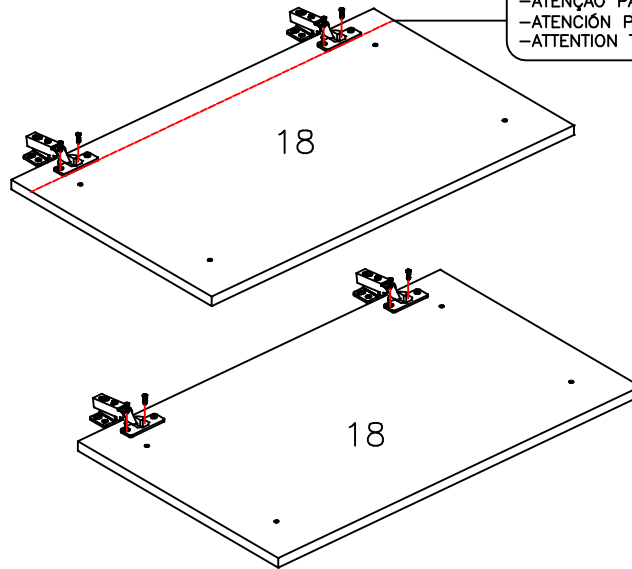

11 PASSO/ PASO/ STEP

S2		6
----	--	---

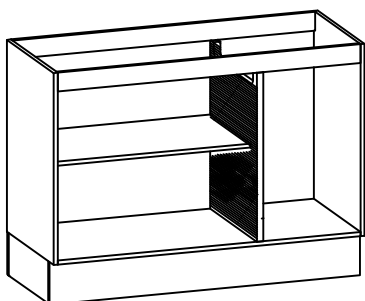
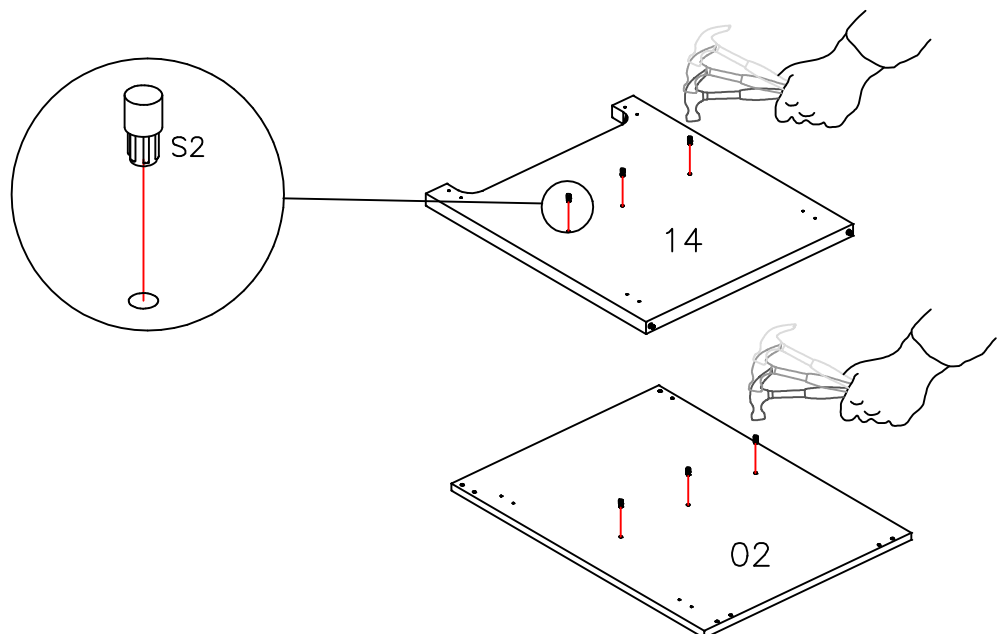



12 PASSO/ PASO/ STEP

NOTE:Nessa versão, foi optado por indicar as gavetas para o lado direito. Caso haja a necessidade de montar para o lado esquerdo, utilize as marcações contidas na lateral.



NOTES:En esta versión, se optó por indicar los cajones del lado derecho. Si es necesario montarlo en el lado izquierdo, use las marcas en el costado.

NOTAS:In this version, it was decided to indicate the drawers for the right side. If there is a need to mount to the left side, use the markings on the side.

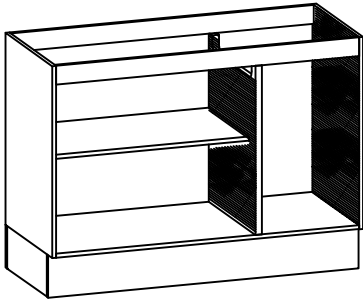
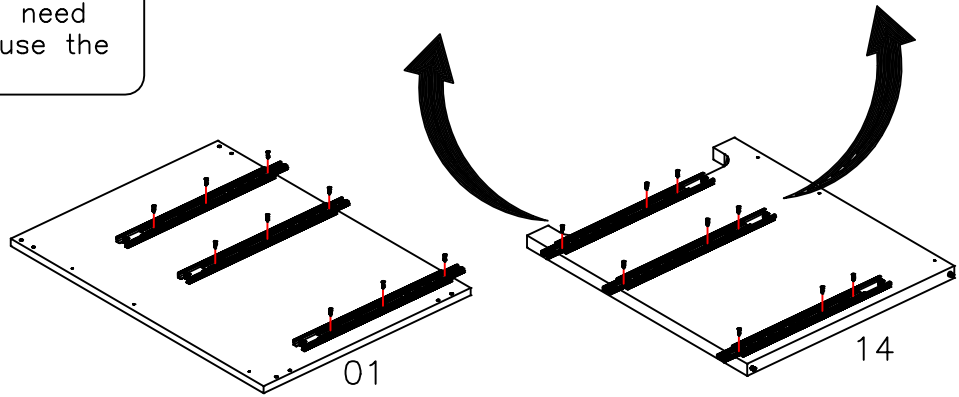
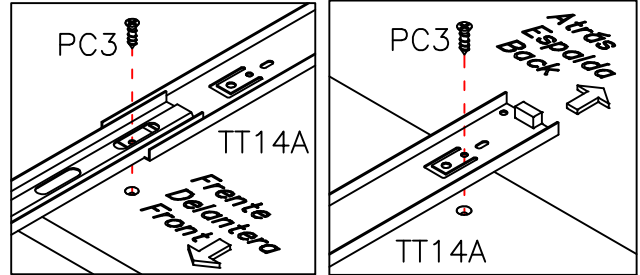
TT14A		6
PC3		18

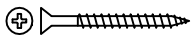

13 PASSO/ PASO/ STEP

PC8		10
TP2		10

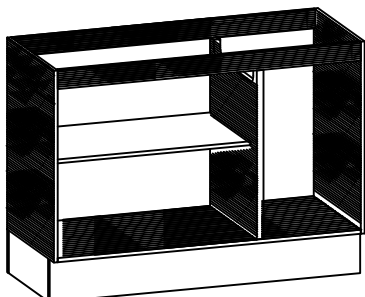
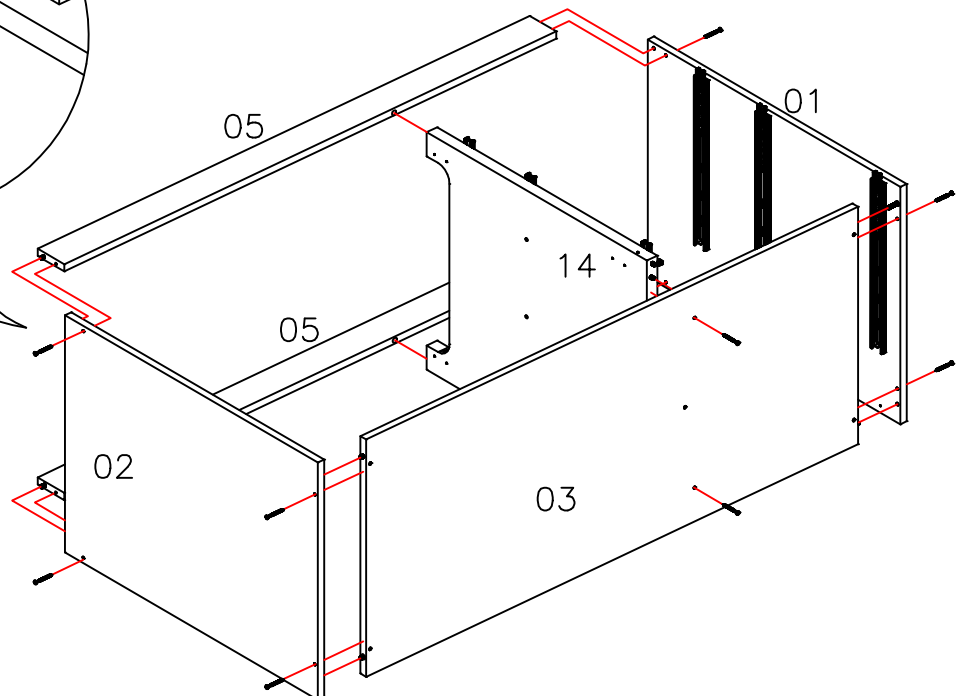
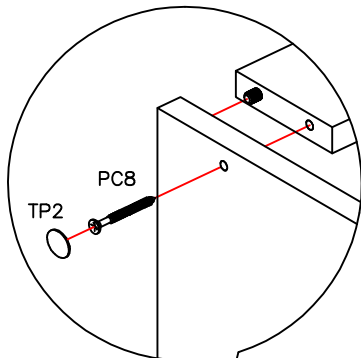

14 PASSO/ PASO/ STEP

PC3		8
-----	---	---

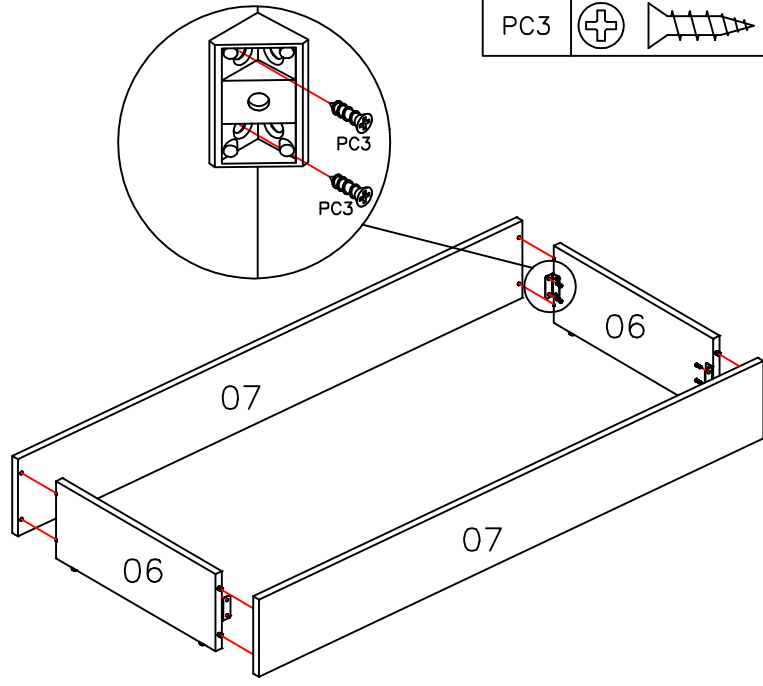
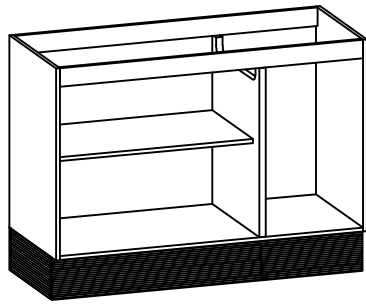



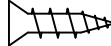

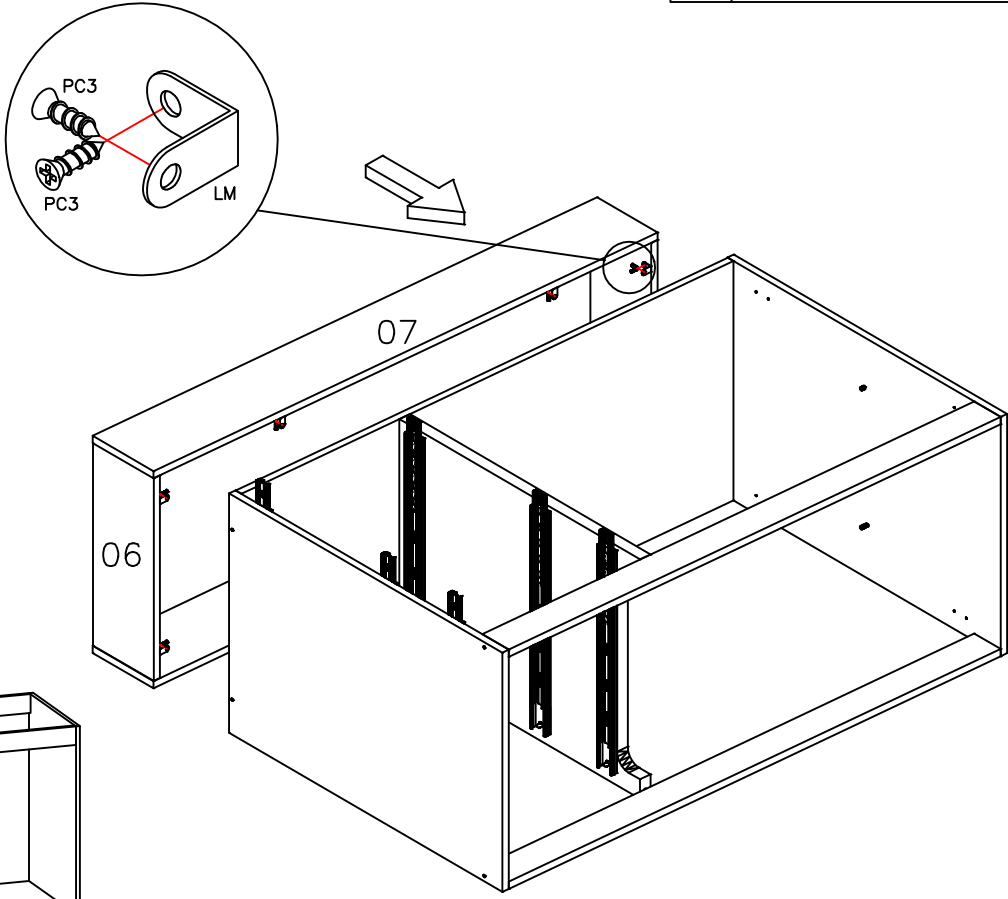
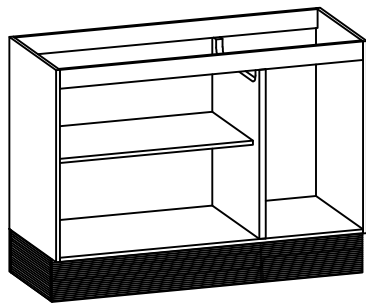
15 PASSO/ PASO/ STEP

LM		8
PC3		16

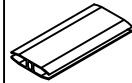

16 PASSO/ PASO/ STEP

PR1		32
PC3		17
PH		1
FC		6
LM		2

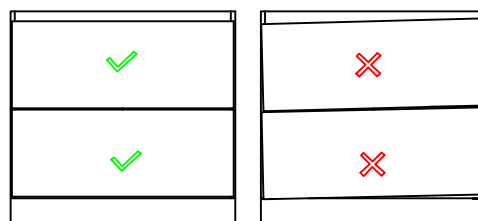
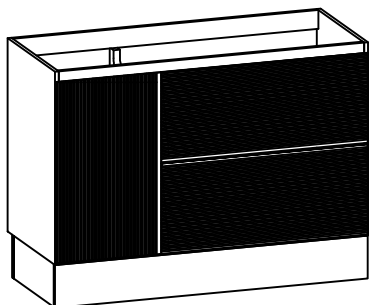
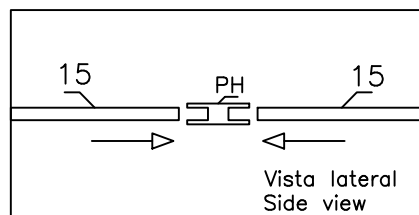
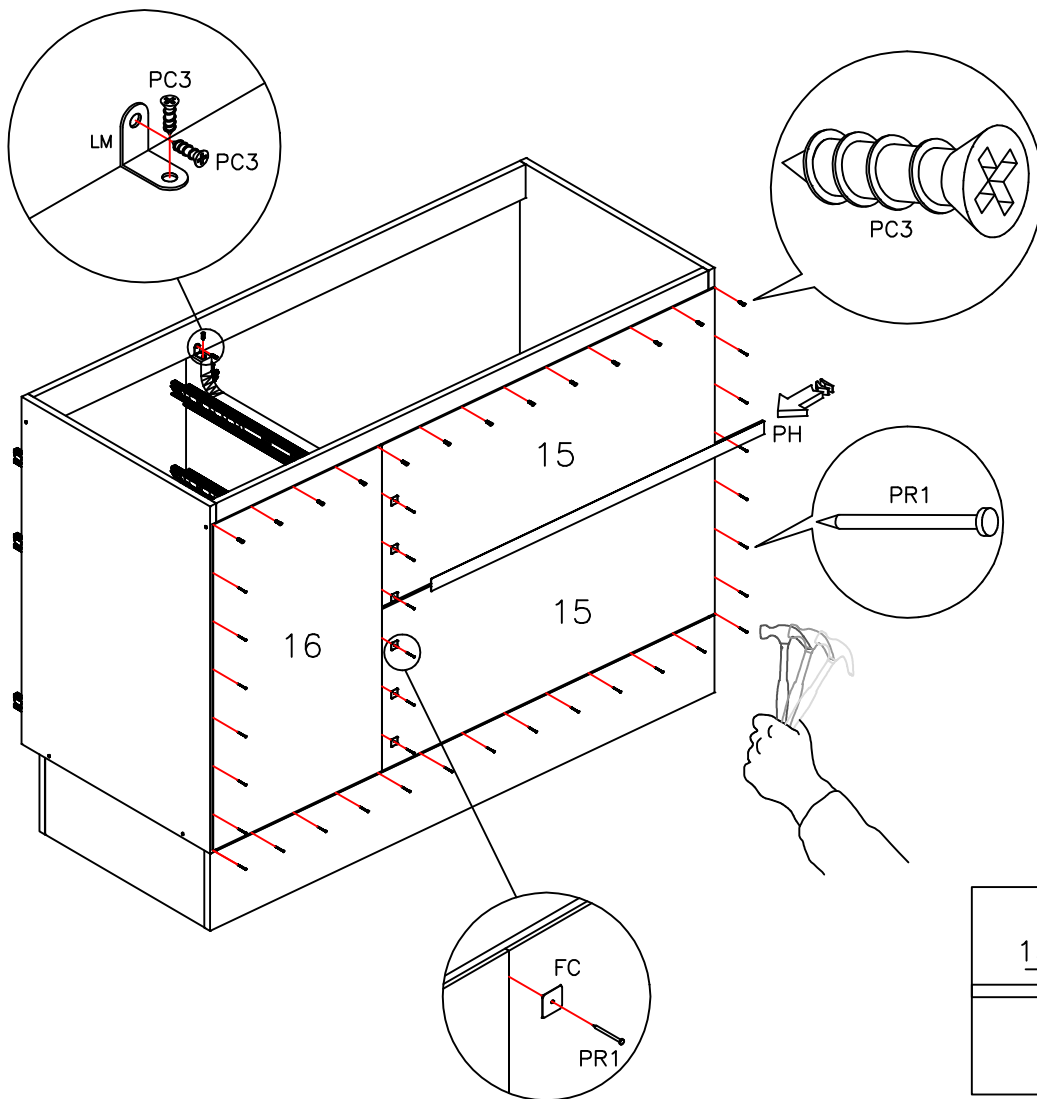



17 PASSO/ PASO/ STEP

NOTA: Nessa versão, foi optado por indicar a dobradiça para o lado direito. Caso haja a necessidade de montar para o lado esquerdo, utilize as marcações contidas na lateral.

NOTAS: En esta versión, se eligió indicar la bisagra en el lado derecho. Si es necesario montarlo en el lado izquierdo, use las marcas en el costado.

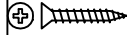
NOTE: In this version, it was chosen to indicate the hinge to the right side. If there is a need to mount to the left side, use the markings on the side.

PP1		16
PC4		4
PX		2
GS		4

NOTA: Utilize o furo oblongo para posicionar a altura da dobradiça. E por fim quando a porta estiver posicionada de maneira correta utilize o furo circular para garantir que a mesma não se desloque.

NOTAS: Utilice o furo oblongo para posicionar a altura da dobradiça. E por fim quando a porta estiver posicionada de maneira correta utiliza o furo circular para garantir que a mesma não se desloque.

NOTE: Use the oblong edge to position at the height of the dobradiça. And for this reason, when the estiver holder is positioned in a correct way, use a circular hole to ensure that it does not loosen at the same time.

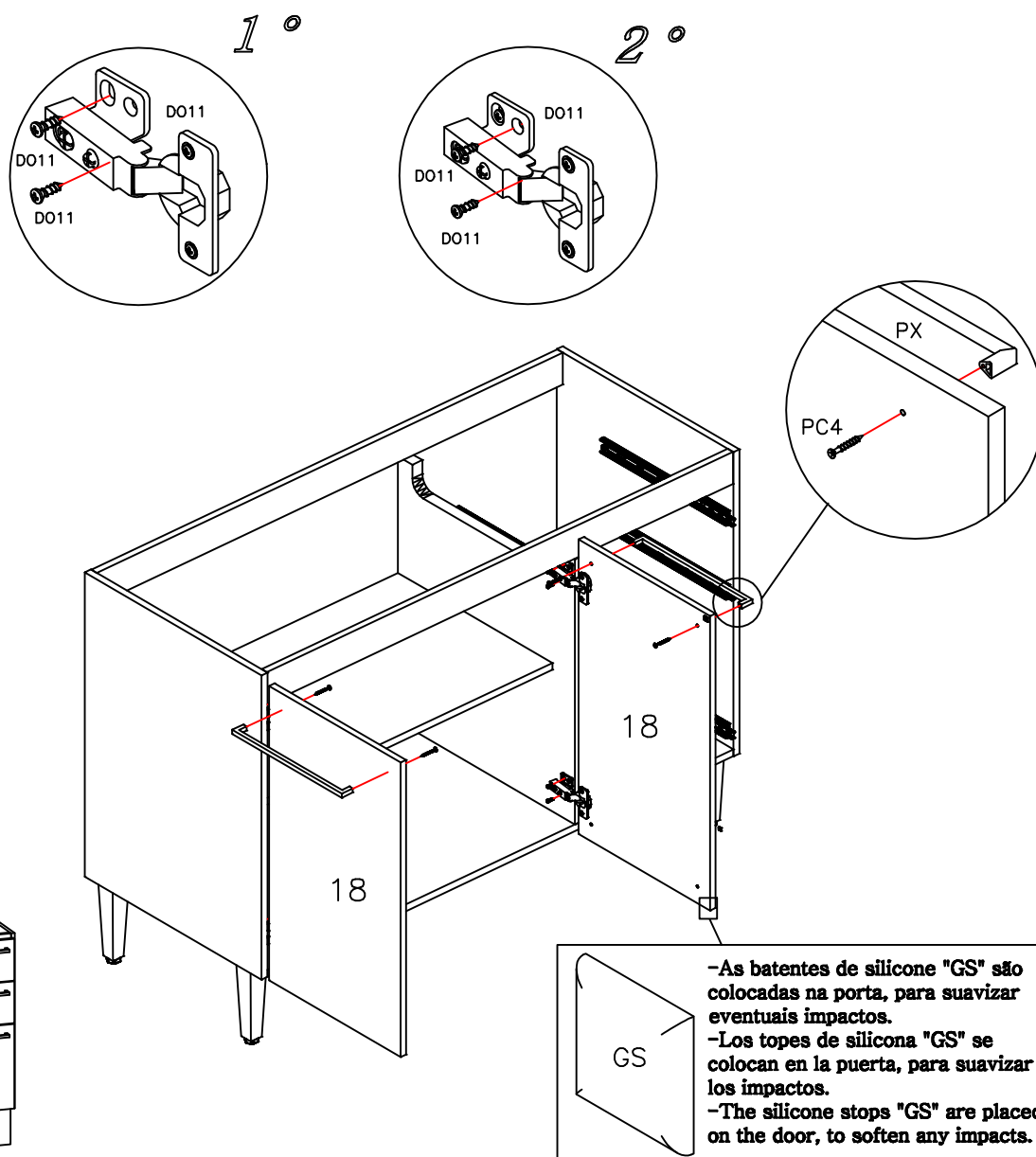

18 AJUSTE DE PORTAS / AJUSTE DE PUERTA / DOORS ADJUSTMENT

REGULAGEM VERTICAL / AJUSTE VERTICAL / VERTICAL ADJUSTMENT

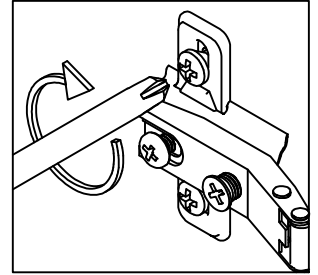
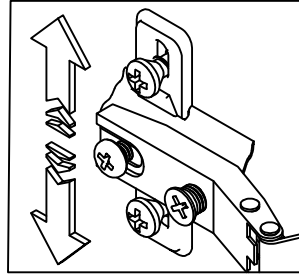
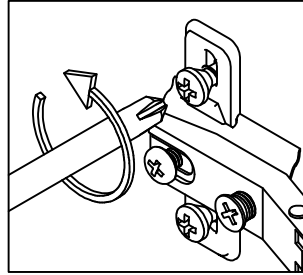
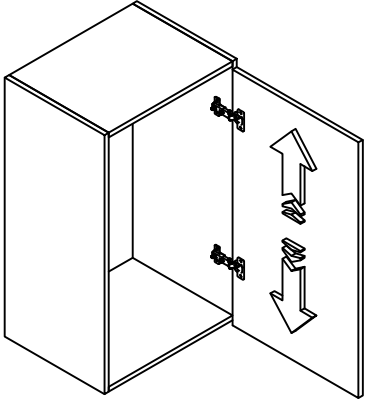

REGULAGEM PROFUNDIDADE / AJUSTE PROFUNDIDAD / DEPTH ADJUSTMENT

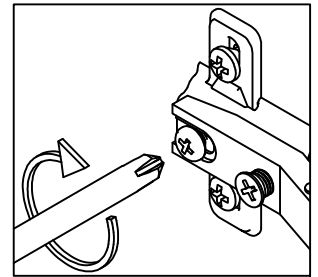
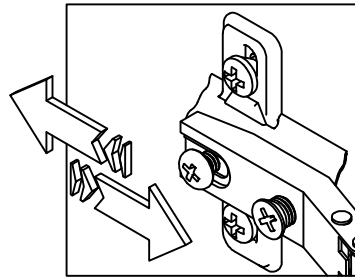
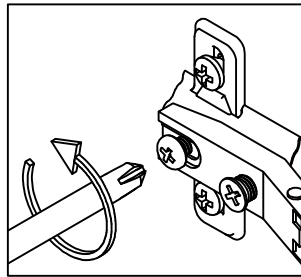
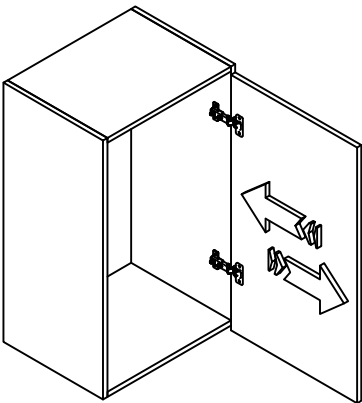

REGULAGEM HORIZONTAL / AJUSTE HORIZONTAL / HORIZONTAL ADJUSTMENT

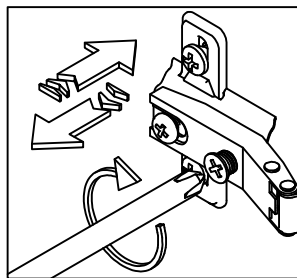
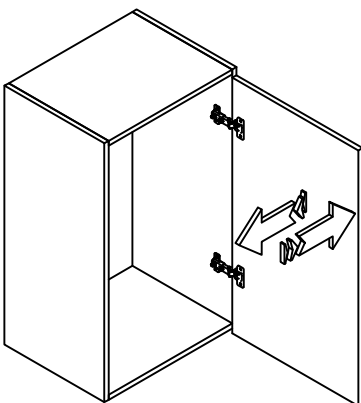

19 PASSO/ PASO/ STEP

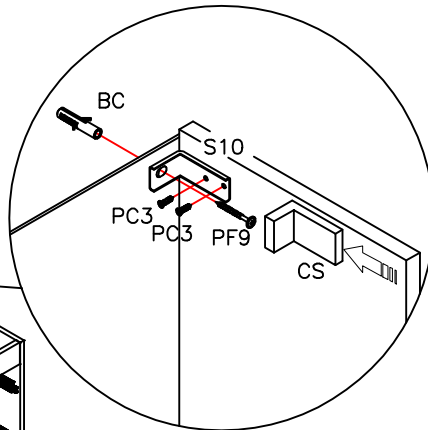
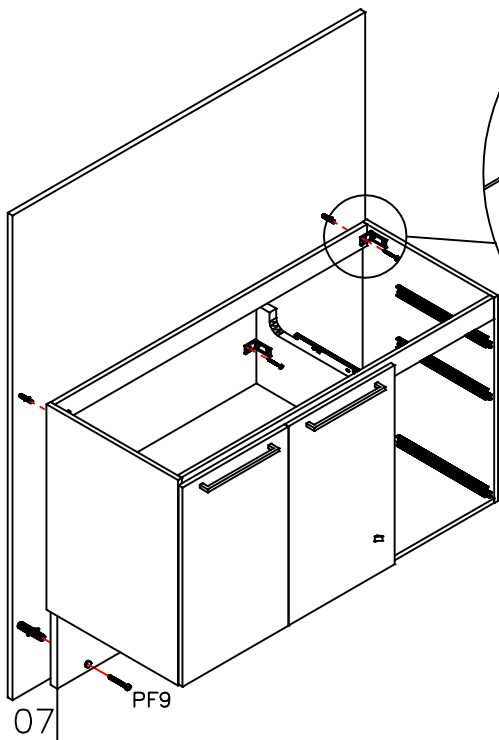

PC3		6
PC4		2
PF9		5
S10		3
CS		3
BC		5
TP2		2

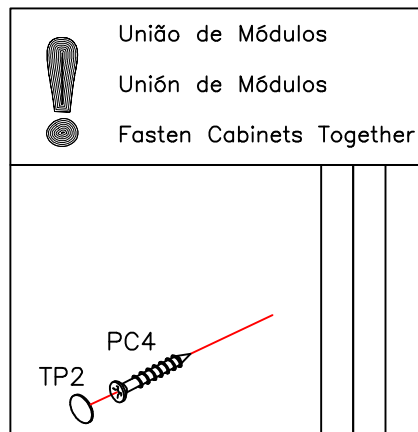

Para montar a cozinha suspensa:

- Utilize o rodapé "07" que acompanha o móvel como apoio para sua fixação na parede, utilizando a bucha "BC" e o parafuso "PF9".
- Em cada lateral fixe um suporte aéreo metalizado "S10" com o parafuso "PC3" e na parede com o parafuso "PF9" e com a bucha "BC".
- Coloque uma capa "CS" em cada suporte "S10".

Para montar la cocina suspendida:

- Utilizar el rodapié "07" que viene con el mueble como soporte para fijarlo a la pared, mediante el casquillo "BC" y el tornillo "PF9".
- En cada lado, fijar un soporte aéreo metalizado "S10" con el tornillo "PC3" y en la pared con el tornillo "PF9" y con el casquillo "BC".
- Colocar una funda "CS" en cada soporte "S10".

To assemble the suspended kitchen:

- Use the baseboard "07" that comes with the furniture as a support for fixing it on the wall, using the "BC" bushing and the "PF9" screw.
- On each side, fix a metalized aerial support "S10" with the screw "PC3" and on the wall with the screw "PF9" and the bushing "BC".
- Place a cover "CS" on each support "S10".

20 PASSO/ PASO/ STEP

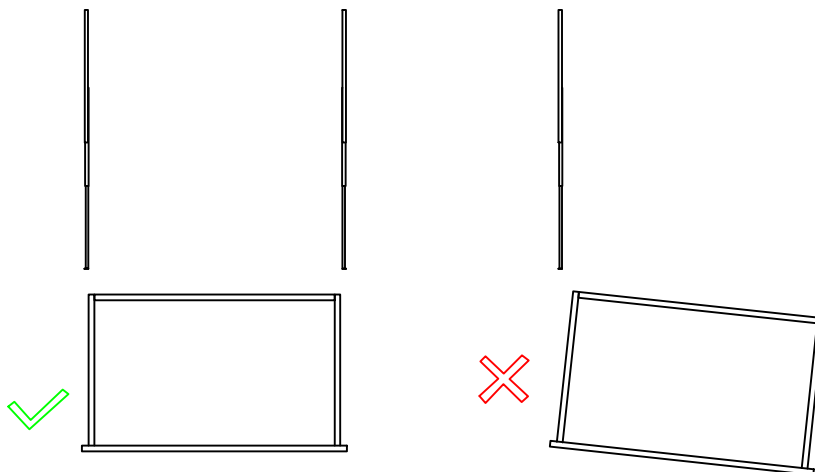
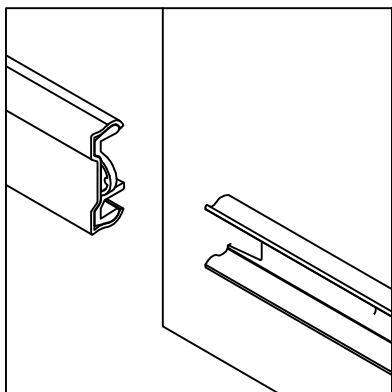
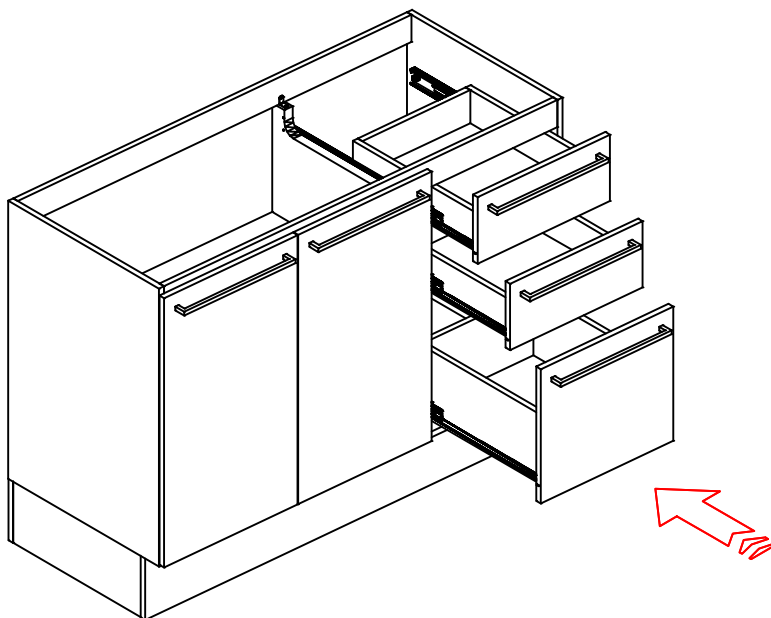
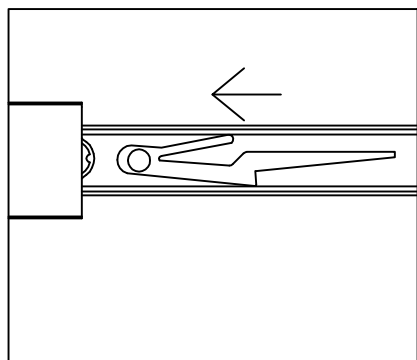
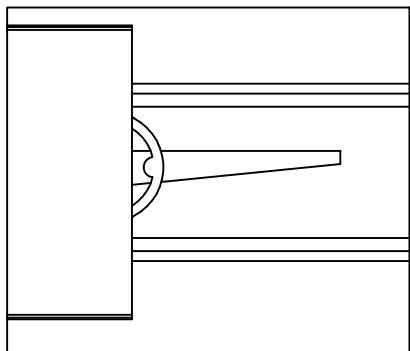

⚠ Não removível
No removable
Not removable

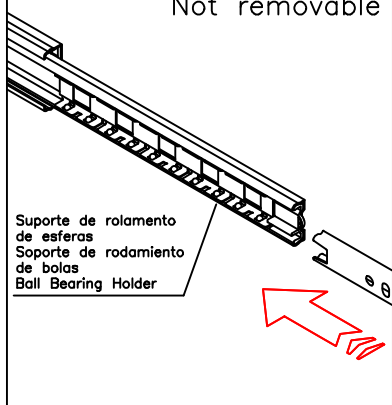

Suporte de rolamento de esferas
Soporte de rodamiento de bolas
Ball Bearing Holder

Para que a corrediça telescópica funcione corretamente, é extremamente importante que o suporte do rolamento de esferas (no Diagrama) seja puxado para frente na seção em que se encontra. Desta forma, a gaveta deslizará corretamente para o lugar.

Para que la guía telescópica funcione correctamente, es extremadamente importante que el soporte del rodamiento de bolas (en el diagrama) se tire hacia adelante en la sección que se encuentra. De esta manera, el cajón se deslizará correctamente en su lugar.

For the Telescopic slide to work properly, is the extremely important that the Ball Bearing holder (in Diagram) is pulled forward in the section it is found. This way the drawer will properly slide into place.

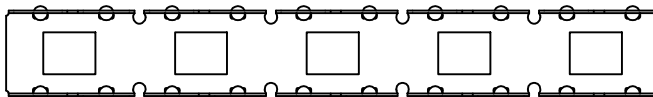

⚠ Ilustração da peça
Ilustración de pieza
Piece illustration ⚠

21 PASSO/ PASO/ STEP

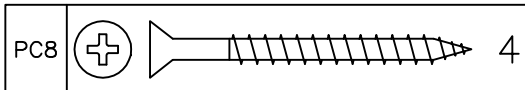



Produto segue com manual de instalação e todas as ferragens necessárias para sua montagem, e montagem do tampo. Caso não haja a compra do tampo os acessórios que contém no mesmo irão sobrar.

Producto a continuación con manual de instalación y todos los herrajes necesarios para su montaje, y montaje de la encimera. Si no hay compra de la tapa, los accesorios que contiene se mantendrán.

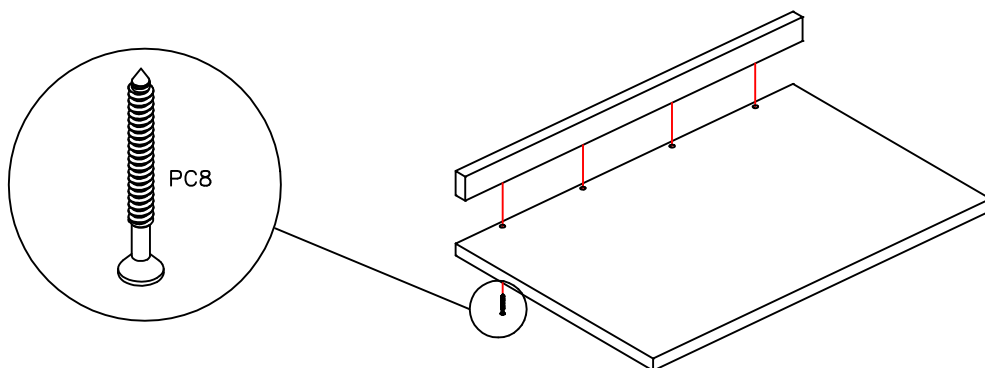
Product follows with installation manual and all the necessary hardware for its assembly, and assembly of the worktop. If there is no purchase of the top, the accessories it contains will remain.

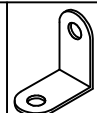

22 PASSO/ PASO/ STEP

LM		6
PC3		12

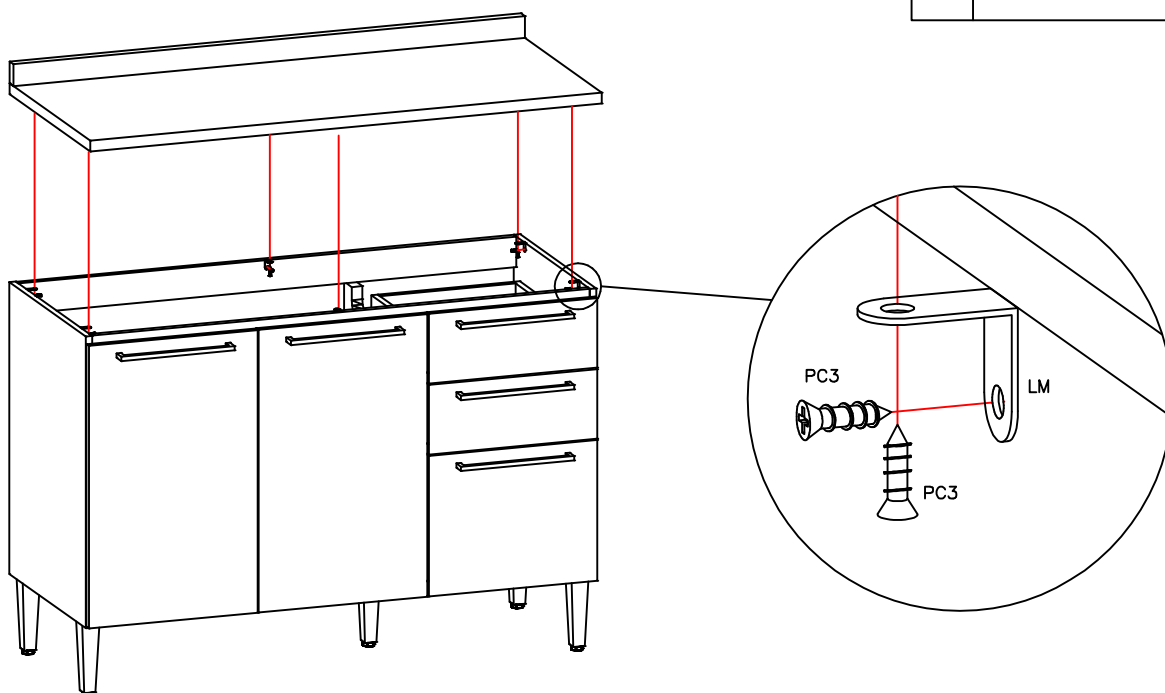

REF.: E609

Rua da Emancipação, 2000 - Tupandi - RS
Fone: (51) 3635-8800

"GARANTIA POR DEFEITO DE FABRICAÇÃO DE 3 MESES."

Os "L" de metal e os parafusos para fixar o tampo e o sarrafo do tampo estão dentro do acessório do Balcão.

1º PASSO

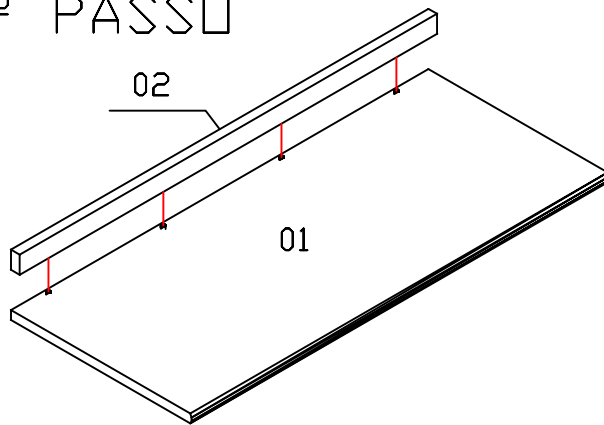

RELAÇÃO DE PEÇAS

- 01-TAMPO
- 02-SARRAFO DO TAMPO



OBS: Para solicitar assistência técnica, utilize o código das peças indicada.

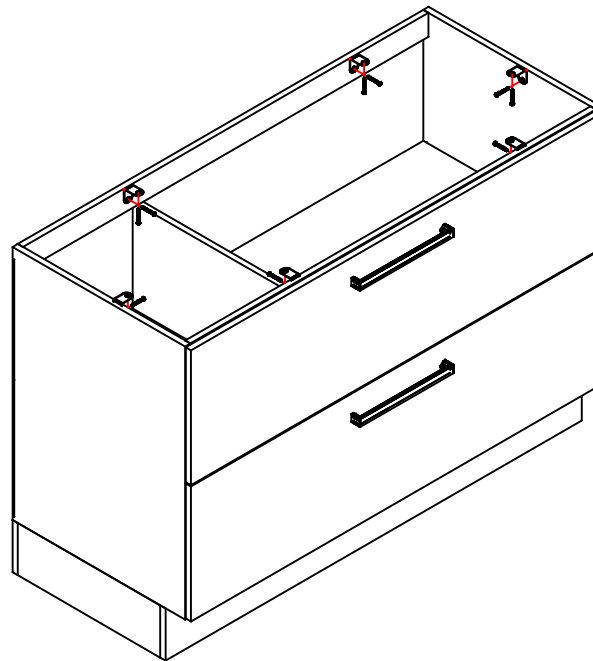

2º PASSO

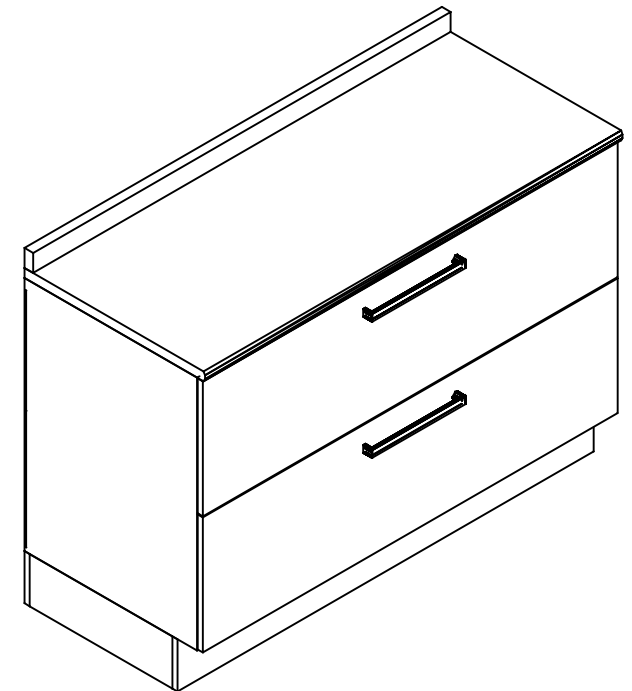

ASPECTO FINAL