

ASPECTO MONTADO / ASSEMBLY ASPECT /
ASPECTO LISTO

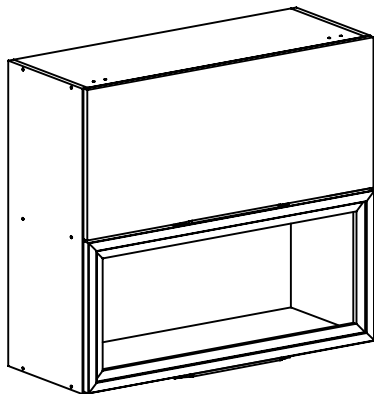

REF. 8936, 8937, 8907 e 8908

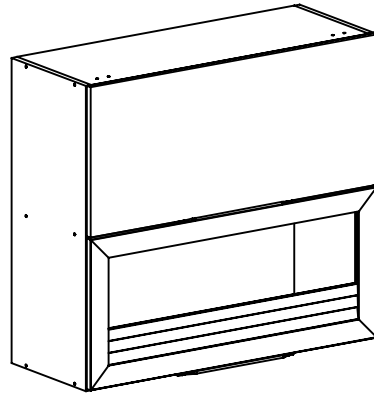

REF. 8964, 8965, 8953 e 8954

ASPECTO TRASEIRO / BOTTOM ASPECT /
ASPECTO TRASERO

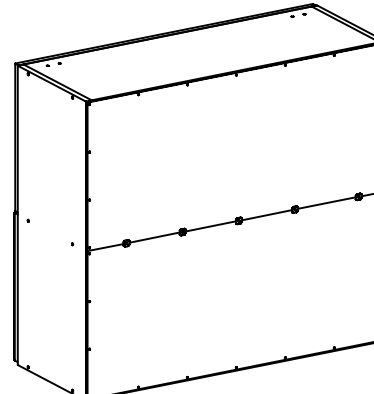

LISTA DE ACESSÓRIO / ACCESSORY LIST /
LISTAJE DE ACCESORIO - 1X1

	A 06 911268 - PARAF. 3,5X12 CHATA CABEÇA 6,8
	B 12 907532 - PARAF. 4,0X12 CABEÇA PANELA
	C 08 903571 - PARAF. M4X25
	D 04 909192 - PARAFUSO 3,5X25 CHATO
	E 12 903542 - PARAF. 3,5X40
	F 02 903563 - PARAF. 6,0X50
	G 30 904801 - PREGO 09X09
	H 12 902913 - CAVILHA 8X30
	I 08 905126 - PORCA SEXTAVADA M4
	J 02 900053 - BUCHA 08

LISTA DE PEÇAS / LIST OF PIECE / LISTAJE DE PIEZAS

Nº	COD	NOME DA PEÇA / NAME OF THE PIECE / NOMBRE DE LA PIEZA	MEDIDA	QTDE	MAT. PRIMA
VOLUME 01					
01	111797	ACESSÓRIO DE MONTAGEM / ASSEMBLY ACCESSORY / ACCESORIO DE MONTAJE	-	01	DIVERSOS
02	110989.0720.0295	LATERAL DIREITA / RIGHT LATERAL / LATERAL DERECHA	720x295x15	01	MDP
03	110990.0720.0295	LATERAL ESQUERDA / LEFT LATERAL / LATERAL IZQUIERDA	720x295x15	01	MDP
04	110618.0770.0295	BASE / BASE / BASE	770x295x15	01	MDP
05	110994.0770.0295	CHAPÉU / HAT / CUBIERTA	770x295x15	01	MDP
06	110991.0770.0295	PRATELEIRA II / SHELF II / REPISA II	770x295x15	01	MDP
VOLUME 02 - REF 8936, 8937, 8907 E 8908					
07	910605	PORTA VIDRO BASC. / HORIZONTAL GLASS DOOR / PUERTA DE VIDRIO HORIZONTAL	795x355x20	01	MDF/VIDRO
08	111771.0795.0355	PORTA BASCULANTE / HORIZONTAL DOOR / PUERTA HORIZONTAL	795x355x15	01	MDP
09	101631.0795.0357	TRASEIRO / BOTTOM / TRASERO	795x357x03	02	MADEFIBRA
VOLUME 02 - REF 8964, 8965, 8953 E 8954					
10	912414	PORTA VENEZIANA C/ VIDRO / SHUTTERS DOOR WITH GLASS / PUERTA VENECIANA CON VIDRIO	795x355x15	01	MDF/VIDRO
08	111771.0795.0355	PORTA BASCULANTE / HORIZONTAL DOOR / PUERTA HORIZONTAL	795x355x15	01	MDP
09	101631.0795.0357	TRASEIRO / BOTTOM / TRASERO	795x357x03	02	MADEFIBRA

CÓDIGOS IDENTIFICADOS NO TOPO DA MAIORIA DAS PEÇAS DO PRODUTO.
 THESE CODES ARE IDENTIFIED ON THE SIDE OF MOST PARTS OF THE PRODUCT.
 CÓDIGO IMPRESO EN EL CANTO CRUDO DE LA MAYORIA DE LAS PIEZAS.

- FERRAMENTAS NECESSÁRIAS P/ MONTAGEM. (NÃO SÃO FORNECIDAS)
- REQUIRED TOOLS FOR ASSEMBLY. (NOT PROVIDED)
- HERRAMIENTAS NECESARIAS. (NO PROPORCIONADAS)

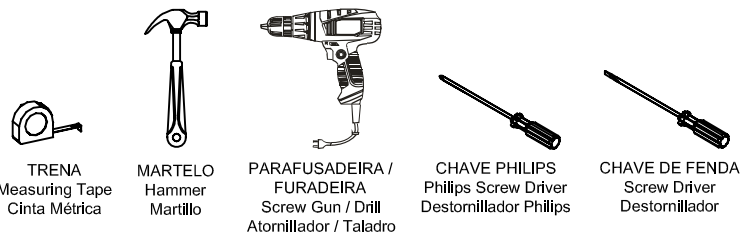

- PESSOAS NECESSÁRIAS PARA MONTAGEM.
- REQUIRED PEOPLE FOR ASSEMBLY.
- CANTIDAD DE PERSONAS NECESARIAS P/ ARMAR.



LISTA DE ACESSÓRIO / ACCESSORY LIST /
LISTAJE DE ACCESORIO

	K 02 903341 - FIXADOR L CANTONEIRA METÁLICA		P 06 910914 - KIT COM 2 TAPA FURO ADESIVO 13MM
	L 02 901635 - FIXADOR L CAPA PLÁSTICA		Q 02 900434 - SUPORTE A GÁS
	M 02 908736 - DOBRADIÇA ALTA 35MM		R 05 900456 - FIXADOR P/ FUNDO
	N 02 908737 - DOBRADIÇA BAIXA 35MM		S 01 911370 - PUXADOR 256MM ESP 20
	O 04 908738 - CALÇO DA DOBRADIÇA 3MM		T 01 911354 - PUXADOR 256MM ESP 15



ESTRUTURA / STRUCTURE / ESTRUCTURA

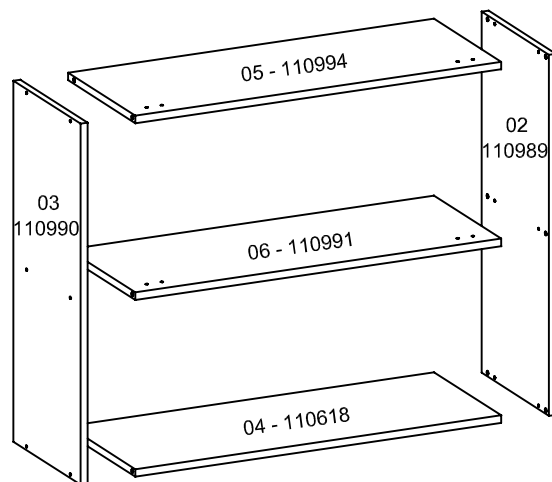

TRASEIRO / BOTTOM / TRASERO

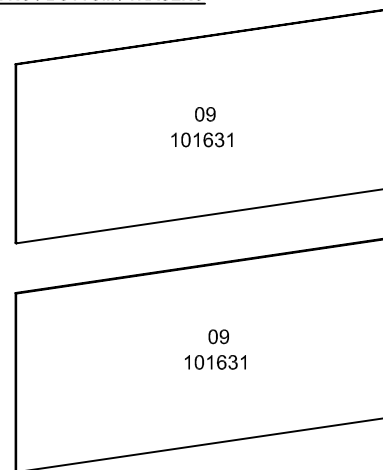

FRENTE / FRONT / FRENTE

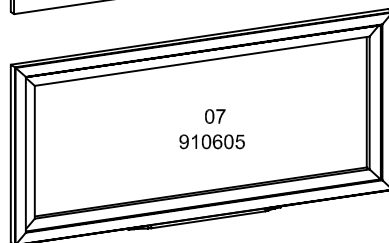
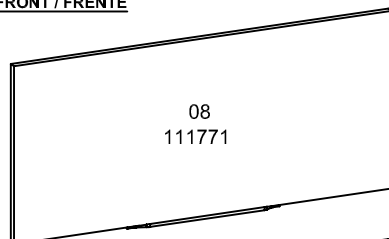

REF. 8936, 8937, 8907 E 8908

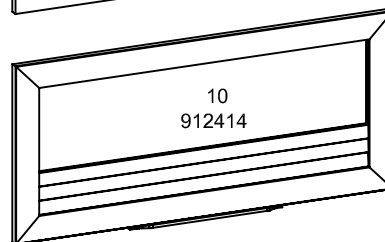
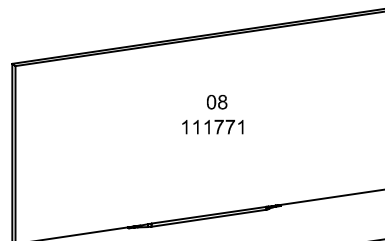

REF. 8964, 8965, 8953 E 8954

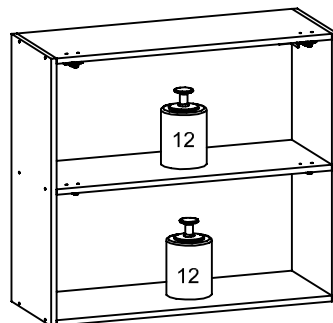

- * LIMITE DE PESO MÁXIMO SUPORTADO (KG).
- * WEIGHT CAPACITY (KG).
- * CAPACIDAD DE PESO (KG).

- CONSIDERAR UM PESO BEM DISTRIBUÍDO POR TODO O PRODUTO.
- CONSIDER A WELL DISTRIBUTED WEIGHT IN ALL THE PRODUCT.
- CONSIDERAR UN PESO BIEN DISTRIBUIDO EN TODO EL PRODUCTO.

ATENÇÃO / ATTENTION / ATENCIÓN:

- A LIMPEZA DO MÓVEL DEVE SER EFETUADA SOMENTE COM PANO MACIO E MODERADAMENTE UMEDECIDO COM ÁGUA PURA OU SOLUÇÃO COM SABÃO NEUTRO.
- FOR CLEANING, USE ONLY A SOFT CLOTH MODERATELY MOISTENED WITH PURE WATER OR A SOLUTION WITH NEUTRAL SOAP.
- PARA LIMPIEZA DEL MUEBLE USAR PAÑO SUAVE Y MODERADAMENTE HUMEDECIDO CON AGUA PURA O SOLUCIÓN CON JABÓN NEUTRO.
- NÃO UTILIZE PRODUTOS QUÍMICOS OU ABRASIVOS, TAIS COMO: CERA, ÁLCOOL, DETERGENTES, TINNER.
- DO NOT USE CHEMICAL OR ABRASIVE PRODUCTS. FOR EXAMPLE: WAX, ALCOHOL, DETERGENT, THINNER.
- NO APLICAR PRODUCTOS QUÍMICOS O ABRASIVOS TAIS COMO: CERAS,ALCOOL, THINNER, DETERGENTE.
- AO SOLICITAR ASSISTÊNCIA TÉCNICA, INFORME O CÓDIGO DO PRODUTO, A COR E O CÓDIGO DA PEÇA CORRETAMENTE.
- WHEN REQUESTING TECHNICAL ASSISTENCE, INFORM THE PRODUCT CODE, THE COLOR AND THE PIECE CODE CORRECTLY.
- SI NECESITAR REPUESTOS, INFORMAR EL CÓDIGO DEL PRODUCTO, EL COLOR Y EL CÓDIGO DE LA PIEZA.

PARA UNIÃO DOS MÓDULOS, FAZER USO DO PARAF. 3,5X25 (D).
FOR THE MODULES UNION, USE SCREW 3,5X25 (D).
PARA LA UNIÓN DE LOS MODULOS, USE EL TORNILLO 3,5X25 (D)

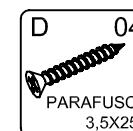
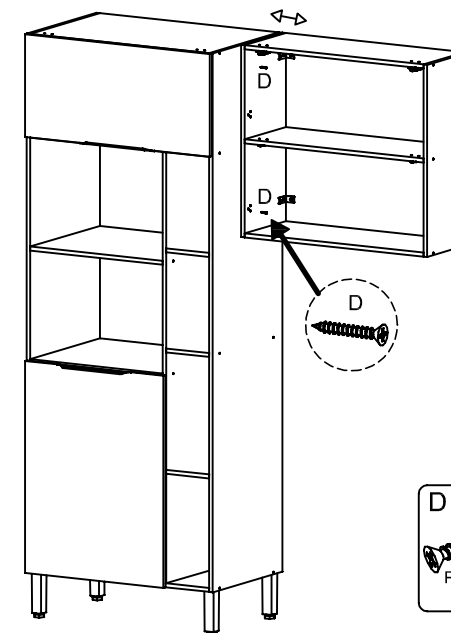



① MONTAGEM DA ESTRUTURA.
STRUCTURE ASSEMBLY.
MONTAJE DE LA ESTRUCTURA.

- B** 04
PARAFUSO 4,0X12
- C** 08
PARAFUSO M4X25
- E** 12
PARAFUSO 3,5X40
- H** 12
CAVILHA 8X30
- I** 08
PORCA SEXTAVA M4
- K** 02
FIXADOR L CANT. METAL
- O** 04
CALÇO DA DOBRAD. 3MM

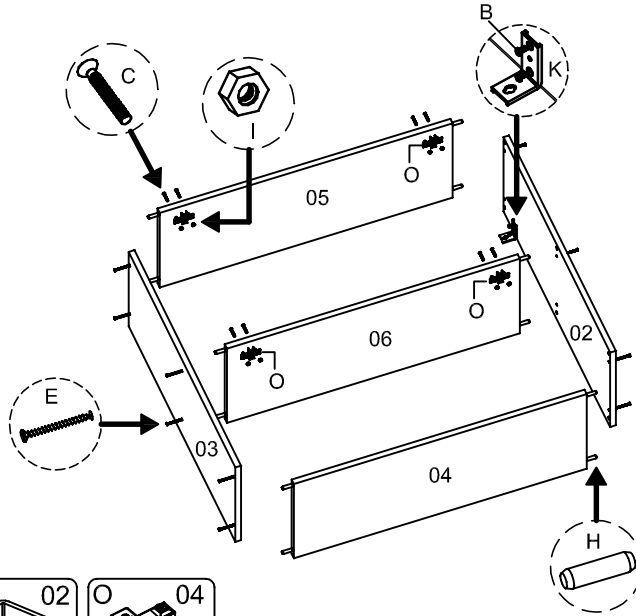

② FIXAÇÃO DOS TRASEIROS.
BOTTOMS ATTACHMENT.
FIJACIÓN DE LOS TRASEROS.

- TIRAR ESQUADRO: MEDIR EM CRUZ PELOS CANTOS DO PRODUTO.
- SQUARING: MEASURE THE OPPOSITE CORNERS OF THE PRODUCT IN CROSSWISE.
- ESCUADRAR: TOMAR LA MEDIDA ENTRE LAS EXTREMIDADES INVERSAS DEL PRODUCTO.

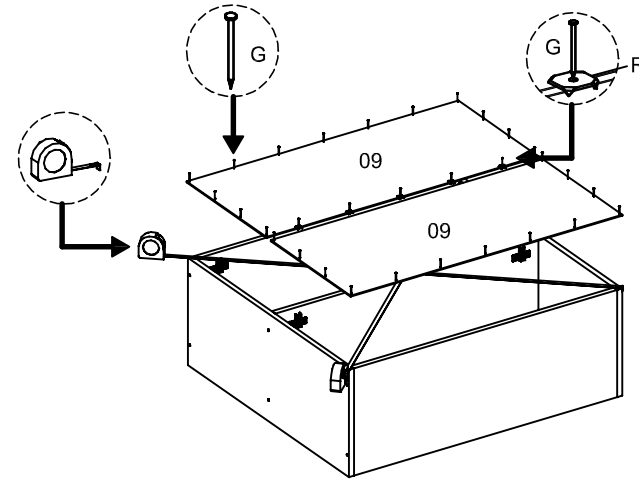

- G** 30
PREGO 09X09
- R** 05
FIXADOR P/ FUNDO

③ COLOCAÇÃO DAS PORTAS BASCULANTES.
HORIZONTAL DOORS PLACEMENT.
COLOCACIÓN DE LAS PUERTAS HORIZONTAL.

- A** 06
PARAFUSO 3,5X12
- B** 08
PARAFUSO 4,0X12
- F** 02
PARAFUSO 6,0X50
- J** 02
BUCHA 08
- L** 02
FIXADOR L CAPA PLÁSTICA
- M** 02
DOBRAD. ALTA 35MM
- N** 02
DOBRAD. BAIXA 35MM
- P** 06
KIT C/2 TAPA FURO ADESIVO
- Q** 02
SUPORTE A GÁS
- S** 01
PUXADOR 256 E6P 20
- T** 01
PUXADOR 256 ESP 15

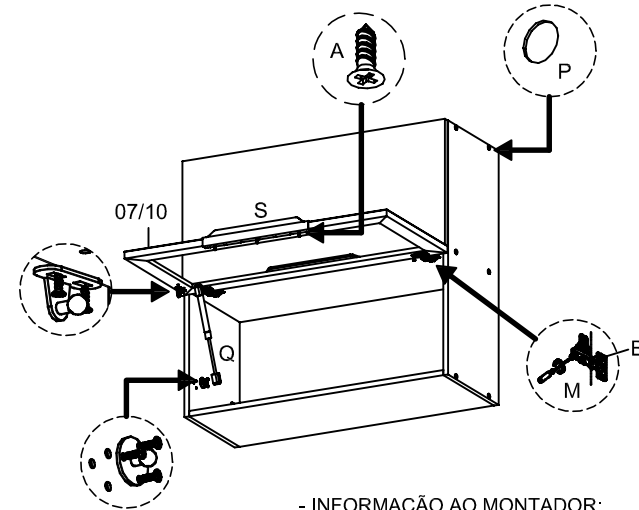
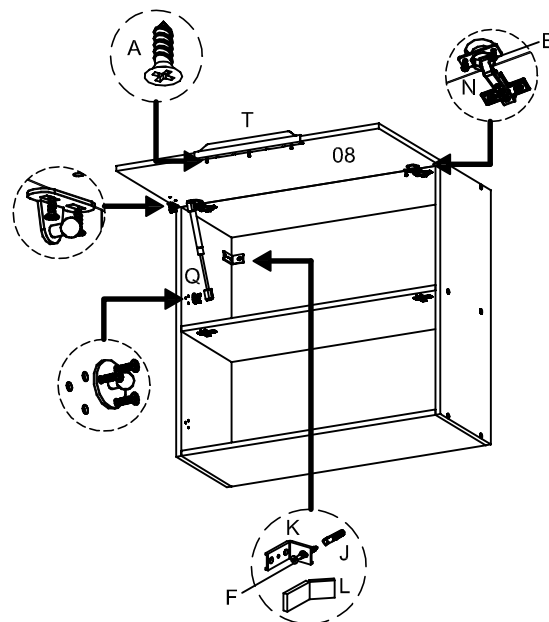

- INFORMAÇÃO AO MONTADOR: USAR PARAFUSADEIRA NO TORQUE BAIXO!
- INFORMATION TO THE ASSEMBLER: USE THE CORDLESS DRILL AT LOW TORQUE.
- INFORMACIÓN AL ARMADOR: UTILIZAR ATORNILLADOR EN TORQUE FLACO.

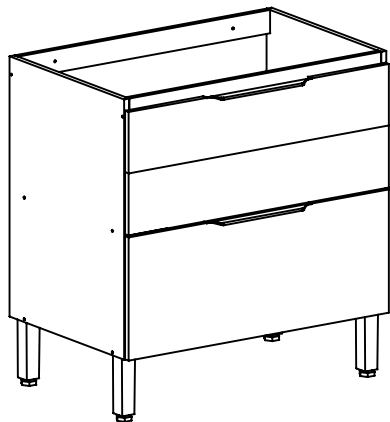
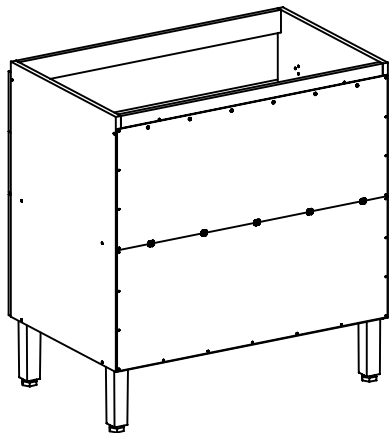
ASPECTO MONTADO / ASSEMBLY ASPECT /
ASPECTO LISTOASPECTO TRASEIRO / BOTTOM ASPECT /
ASPECTO TRASERO

- PESSOAS NECESSÁRIAS P/ MONTAGEM.
- REQUIRED PEOPLE FOR ASSEMBLY.
- CANTIDAD DE PERSONAS NECESARIAS
P/ ARMAR.



1 PESSOA
1 PERSON
1 PERSONA

LISTA DE PEÇAS / LIST OF PIECE / LISTAJE DE PIEZAS

Nº	COD	NOME DA PEÇA / NAME OF THE PIECE / NOMBRE DE LA PIEZA	MEDIDA	QTDE	MAT. PRIMA
VOLUME 01					
01	111999	ACESSÓRIO DE MONTAGEM / ASSEMBLY ACCESSORY / ACCESORIO DE MONTAJE	-	01	DIVERSOS
02	908920	CORREDIÇA (PAR) / SLIDING (EQUAL) / CORREDERA (PAR)	400MM	01	METAL
03	908640	PÉS / FEET / PATA	170MM	04	PLÁSTICO
04	111091.0675.0500	LATERAL DIREITA / RIGHT LATERAL / LATERAL DERECHA	675x500x15	01	MDP
05	111092.0675.0500	LATERAL ESQUERDA / LEFT LATERAL / LATERAL IZQUIERDA	675x500x15	01	MDP
06	102438.0770.0500	BASE / BASE / BASE	770x500x15	01	MDP
07	111051.0770.0500	PRATELEIRA II / SHELF II / REPISA II	770x500x15	01	MDP
09	106923.0770.0060	SUPORTE FRONTAL / FRONT SUPPORT / APOYO FRONTAL	770x60x15	01	MDP
10	109763.0770.0060	SUPORTE TRASEIRO / BOTTOM SUPPORT / APOYO TRASERO	770x60x15	01	MDP
11	111094.0400.0220	LATERAL DE GAV. DIR. / RIGHT DRAWER SIDEBOARD / LATERAL DEL CAJÓN DER.	400x220x15	01	MDP
12	111095.0400.0220	LATERAL DE GAV. ESQ. / LEFT DRAWER SIDEBOARD / LATERAL DEL CAJÓN IZQ.	400x220x15	01	MDP
13	102940.0715.0180	CONTRA FDO DE GAVETA / DRAWER BOTTOM BOARD / CONTRA FONDO DEL CAJÓN	715x180x15	01	MDP
14	105588.0400.0060	SUPORTE FDO DE GAV. / DRAWER BOTTOM SUPPORT / APOYO FONDO DEL CAJÓN	400x60x15	01	MDP
15	102493.0725.0405	FUNDO DE GAVETA / DRAWER BOTTOM / FONDO DEL CAJÓN	725x405x03	01	MADEFIBRA
VOLUME 02					
16	112002.0795.0320	PORTA BASCULANTE / HORIZONTAL DOOR / PUERTA HORIZONTAL	795x320x15	01	MDP
17	111954.0795.0320	FRENTE DE GAVETA / DRAWER FRONT / FRENTE DEL CAJÓN	795x320x15	01	MDP
18	111097.0795.0320	TRASEIRO / BOTTOM / TRASERO	795x320x03	02	MADEFIBRA

CÓDIGOS IDENTIFICADOS NO TOPO DA MAIORIA DAS PEÇAS DO PRODUTO.
THESE CODES ARE IDENTIFIED ON THE SIDE OF MOST PARTS OF THE PRODUCT.
CÓDIGO IMPRESO EN EL CANTO CRUDO DE LA MAYORIA DE LAS PIEZAS.

ATENÇÃO / ATTENTION / ATENCIÓN:

- A LIMPEZA DO MÓVEL DEVE SER EFETUADA SOMENTE COM PANO MACIO E MODERADAMENTE UMEDECIDO COM ÁGUA PURA OU SOLUÇÃO COM SABÃO NEUTRO.
- FOR CLEANING, USE ONLY A SOFT CLOTH MODERATELY MOISTENED WITH PURE WATER OR A SOLUTION WITH NEUTRAL SOAP.
- PARA LIMPIEZA DEL MUEBLE USAR PAÑO SUAVE Y MODERADAMENTE HUMEDECIDO CON AGUA PURA O SOLUCIÓN CON JABÓN NEUTRO.
- NÃO UTILIZE PRODUTOS QUÍMICOS OU ABRASIVOS, TAIS COMO: CERA, ÁLCOOL, DETERGENTES, TINNER.
- DO NOT USE CHEMICAL OR ABRASIVE PRODUCTS. FOR EXAMPLE: WAX, ALCOHOL, DETERGENT, THINNER.
- NO APLICAR PRODUCTOS QUÍMICOS O ABRASIVOS TAIS COMO: CERAS,ALCOOL, THINNER, DETERGENTE.
- AO SOLICITAR ASSISTÊNCIA TÉCNICA, INFORME O CÓDIGO DO PRODUTO, A COR E O CÓDIGO DA PEÇA CORRETAMENTE.
- WHEN REQUESTING TECHNICAL ASSISTENCE, INFORM THE PRODUCT CODE, THE COLOR AND THE PIECE CODE CORRECTLY.
- SI NECESITAR REPUESTOS, INFORMAR EL CÓDIGO DEL PRODUCTO, EL COLOR Y EL CÓDIGO DE LA PIEZA.

FERRAMENTAS NECESSÁRIAS P/ MONTAGEM.

(NÃO SÃO FORNECIDAS)
REQUIRED TOOLS FOR ASSEMBLY. (NOT PROVIDED)
HERRAMIENTAS NECESARIAS.
(NO PROPORCIONADAS)



TRENA
Measuring Tape
Cinta Métrica

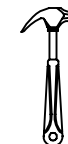

MARTELO
Hammer
Martillo

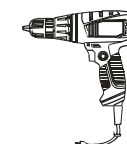

PARAFUSADEIRA /
FURADEIRA
Screw Gun / Drill
Atornillador / Taladro



CHAVE PHILIPS
Phillips Screw Driver
Destornillador Phillips



CHAVE DE FENDA
Screw Driver
Destornillador



LISTA DE ACESSÓRIO / ACCESSORY LIST / LISTAJE DE ACCESORIO - 1X1

	A 12 911268 - PARAF. 3,5X12 CHATA CABEÇA 6,8
	B 26 907532 - PARAF. 4,0X12 CABEÇA PAINELA
	C 04 909192 - PARAFUSO 3,5X25 CHATO
	D 04 903571 - PARAF. M4X25
	E 04 903575 - PARAF. MINIFIX
	F 04 903557 - PARAF. 5,0X35 FLANGEADO
	G 19 903542 - PARAF. 3,5X40

	H 02 903563 - PARAF. 6,0X50
	I 04 905126 - PORCA SEXTAVADA M4
	J 30 904801 - PREGO 09X09
	K 16 902913 - CAVILHA 8X30
	L 02 900205 - CAVILHA ESTRIADA
	M 02 900053 - BUCHA 08

LISTA DE ACESSÓRIO / ACCESSORY LIST / LISTAJE DE ACCESORIO

	N 04 902900 - CANTONEIRA PARA VISTA		S 01 900243 - COLA
	O 04 904981 - TAMBOR MINIFIX		T 02 911354 - PUXADOR 256MM ESP 15
	P 02 908736 - DOBRADIÇA ALTA 35MM		U 02 900437 - SUPORTE A GÁS FORÇA INVERSA
	Q 02 908738 - CALÇO DA DOBRADIÇA 3MM		V 05 900456 - FIXADOR P/ FUNDO
	R 02 905775 - KIT C/ 2 TAPA FURO ADESIVO 15MM		W 06 910914 - KIT C/ 2 TAPA FURO ADESIVO 13MM

* LIMITE DE PESO MÁXIMO SUPORTADO (KG).
* WEIGHT CAPACITY (KG).
* CAPACIDAD DE PESO (KG).

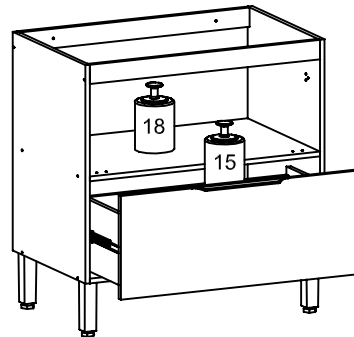

- CONSIDERAR UM PESO BEM DISTRIBUÍDO POR TODO O PRODUTO.
- CONSIDER A WELL DISTRIBUTED WEIGHT IN ALL THE PRODUCT.
- CONSIDERAR UN PESO BIEN DISTRIBUIDO EN TODO EL PRODUCTO.

PARA UNIÃO DOS MÓDULOS, FAZER USO DO PARAF. 3,5X25 (C).
FOR THE MODULES UNION, USE SCREW 3,5X25 (C).
PARA LA UNIÓN DE LOS MÓDULOS, USE EL TORNILLO 3,5X25 (C)

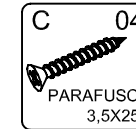
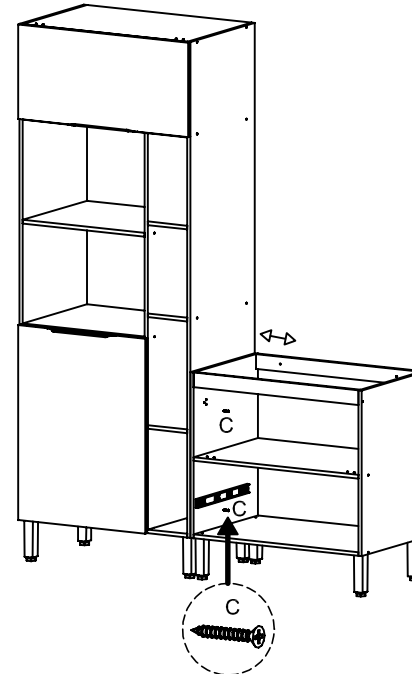

ESTRUTURA
STRUCTURE
ESTRUCTURA

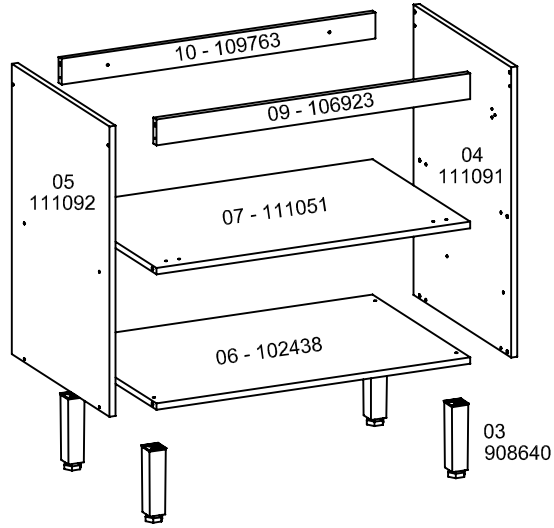

FRENTE
FRONT
FRENTE

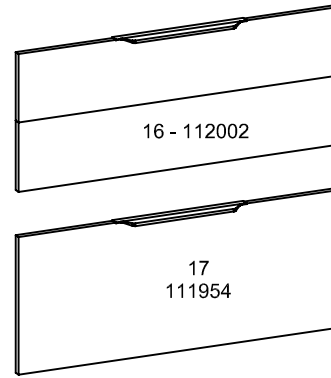

TRASEIRO
BOTTOM
TRASERO

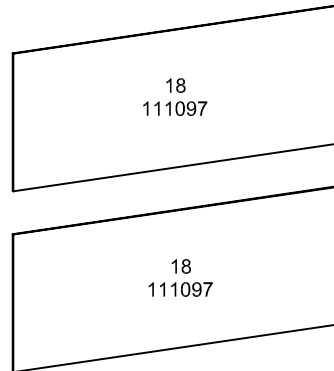

GAVETA
DRAWER
CAJÓN

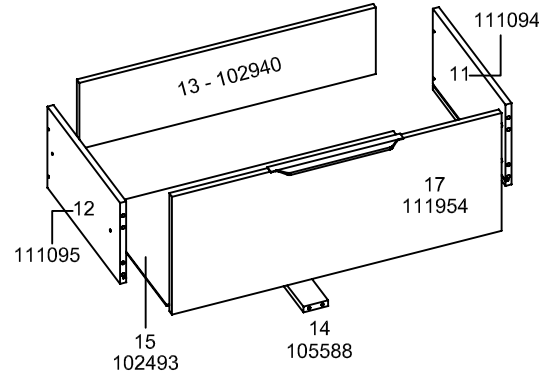

① **MONTAGEM DA GAVETA.**
DRAWER ASSEMBLY.
MONTAJE DEL CAJÓN.

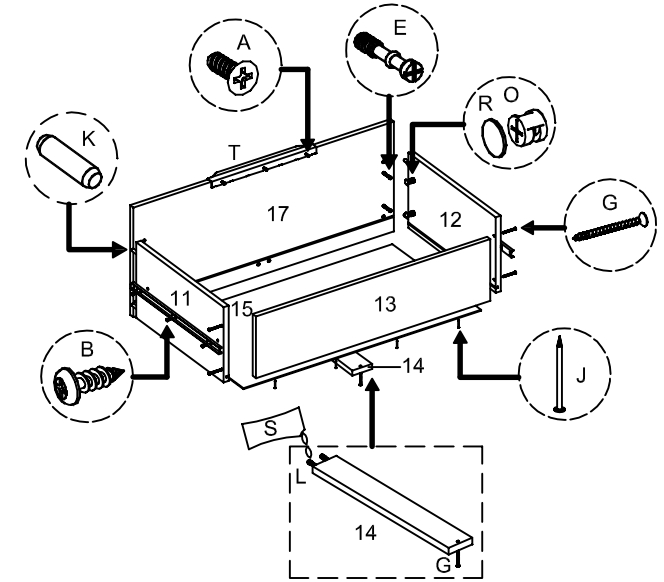

A 03 PARAFUSO 3,5X12	B 06 PARAFUSO 4,0X12	E 04 PARAFUSO MINIFIX	G 05 PARAFUSO 3,5X40
J 04 PREGO 09X09	K 04 CAVILHA 8X30	L 02 CAVILHA ESTRIADA	O 04 TAMBOR MINIFIX
R 02 KIT C/ 2 TAPA FURO 15MM	S 01 COLA	T 01 PUXADOR	

② MONTAGEM DA ESTRUTURA .
STRUCTURE ASSEMBLY.
MONTAJE DE LA ESTRUCTURA.

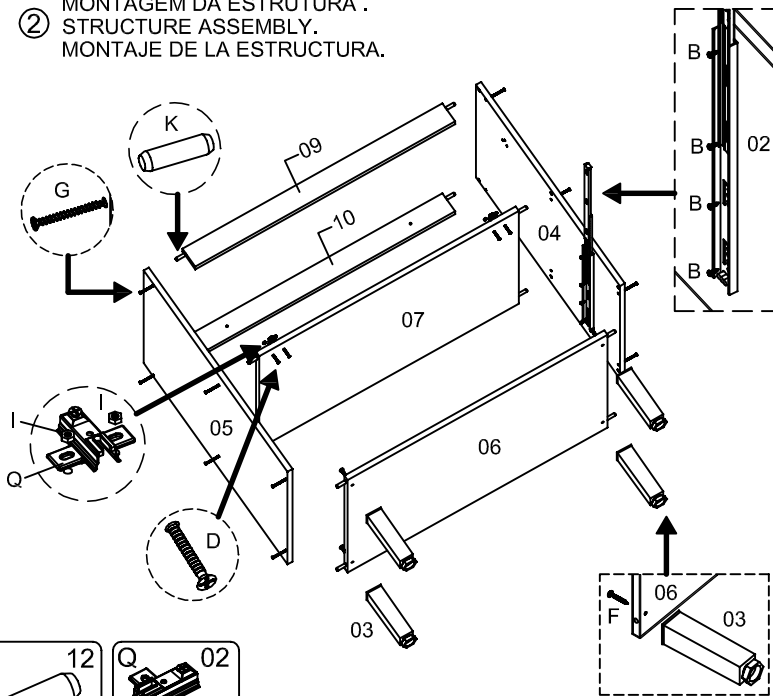
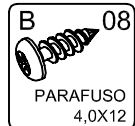

④ COLOCAÇÃO DA PORTA BASCULANTE.
HORIZONTAL DOOR PLACEMENT.
COLOCACIÓN DE LA PUERTA HORIZONTAL.

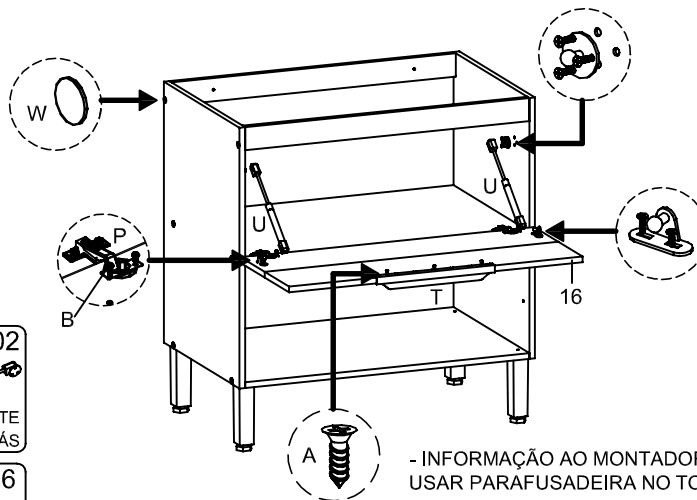
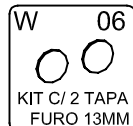
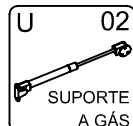
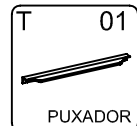
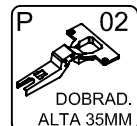
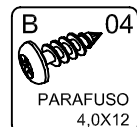

- INFORMAÇÃO AO MONTADOR:
USAR PARAFUSADEIRA NO TORQUE BAIXO!
- INFORMATION TO THE ASSEMBLER:
USE THE CORDLESS DRILL AT LOW TORQUE.
- INFORMACIÓN AL ARMADOR:
UTILIZAR ATORNILLADOR EN TORQUE FLACO.

③ FIXAÇÃO DOS TRASEIROS.
BOTTOMS ATTACHMENT.
FIJACIÓN DE LOS TRASEROS.

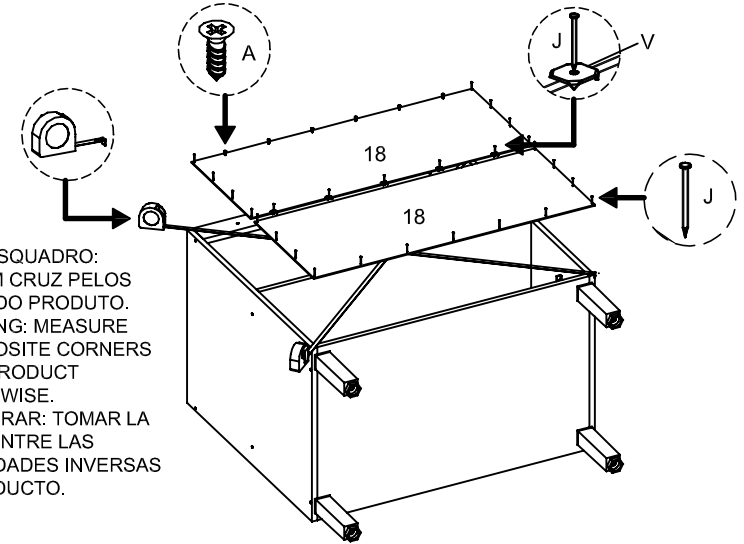

- TIRAR ESQUADRO:
MEDIR EM CRUZ PELOS
CANTOS DO PRODUTO.
- SQUARING: MEASURE
THE OPPOSITE CORNERS
OF THE PRODUCT
IN CROSSWISE.
- ESCUADRAR: TOMAR LA
MEDIDA ENTRE LAS
EXTREMIDADES INVERSAS
DEL PRODUCTO.

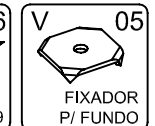
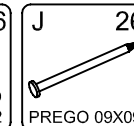

⑤ COLOCAÇÃO DA GAVETA.
DRAWER PLACEMENT.
COLOCACIÓN DEL CAJÓN.

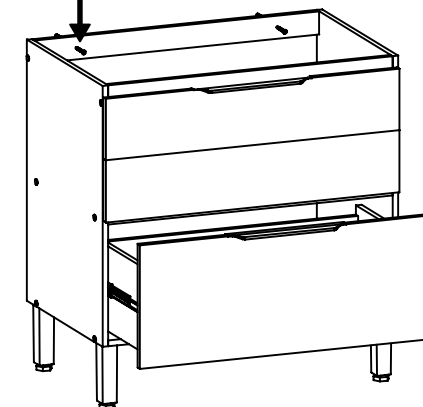
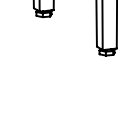
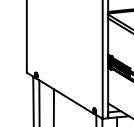
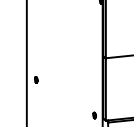
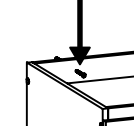
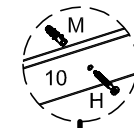

ASPECTO MONTADO / ASSEMBLY ASPECT /
 ASPECTO LISTO

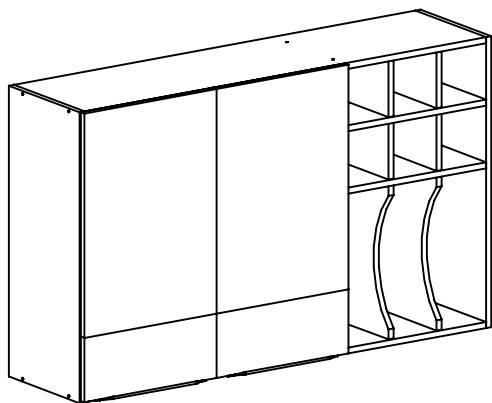

ASPECTO TRASEIRO / BOTTOM ASPECT /
 ASPECTO TRASERO

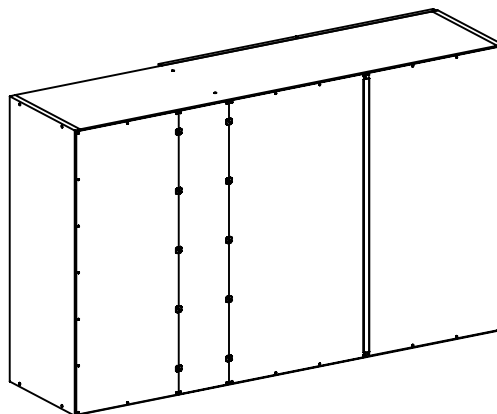

LISTA DE PEÇAS / LIST OF PIECE / LISTAJE DE PIEZAS

Nº	CÓDIGO	NOME DA PEÇA / NAME OF THE PIECE / NOMBRE DE LA PIEZA	MEDIDA	QTDE	MAT. PRIMA
VOLUME 01					
01	111870	ACESSÓRIO DE MONTAGEM / ASSEMBLY ACCESSORY / ACCESORIO DE MONTAJE	-	01	DIVERSOS
02	911413	PERFIL I 690MM / PLASTIC PROFILE I 690MM / PERFIL I 690MM	690MM	01	PLÁSTICO
03	111871.0720.0295	LATERAL DIREITA / RIGHT LATERAL / LATERAL DERECHA	720x295x15	01	MDP
04	110627.0720.0295	LATERAL ESQUERDA / LEFT LATERAL / LATERAL IZQUIERDA	720x295x15	01	MDP
05	111872.0690.0295	DIVISÃO / DIVISION / DIVISIÓN	690x295x15	01	MDP
06	111873.1170.0295	BASE / BASE / BASE	1170x295x15	01	MDP
07	111874.1170.0295	CHAPÉU / HAT / CUBIERTA	1170x295x15	01	MDP
08	111875.0747.0268	PRATELEIRA I ESQUERDA / LEFT SHELF I / REPISA I IZQUIERDA	747x268x15	01	MDP
09	111876.0408.0295	PRATELEIRA II DIREITA / RIGHT SHELF II / REPISA II DERECHA	408x295x15	02	MDP
10	111877.0140.0290	DIVISÃO SUPERIOR NICHO / NICHE UPPER DIVISION / DIVISIÓN SUPERIOR NICHO	140x290x15	04	MDP
11	111878.0380.0290	DIVISÃO INFERIOR CURVA / LOWER CURVED DIVISION / DIVISIÓN INFERIOR CURVA	380x290x15	02	MDP
VOLUME 02					
12	111883.0715.0385	PORTA DIREITA / RIGHT DOOR/ PUERTA DERECHA	715x385x15	01	MDP
13	111884.0715.0385	PORTA ESQUERDA / LEFT DOOR / PUERTA IZQUIERDA	715x385x15	01	MDP
14	111886.0715.0287	TRASEIRO DIREITO / RIGHT BOTTOM / TRASERO DERECHO	715x287x03	01	MADEFIBRA
15	111887.0715.0383	TRASEIRO ESQUERDO / LEFT BOTTOM / TRASERO IZQUIERDO	715x383x03	02	MADEFIBRA
16	111888.0715.0141	TRASEIRO CENTRAL / CENTRAL BOTTOM / TRASERO CENTRAL	715x141x03	01	MADEFIBRA

CÓDIGOS IDENTIFICADOS NO TOPO DA MAIORIA DAS PEÇAS DO PRODUTO.
 THESE CODES ARE IDENTIFIED ON THE SIDE OF MOST PARTS OF THE PRODUCT.
 CÓDIGO IMPRESO EN EL CANTO CRUDO DE LA MAYORIA DE LAS PIEZAS.



- PESSOAS NECESSÁRIAS P/ MONTAGEM.
 - REQUIRED PEOPLE FOR ASSEMBLY.
 - CANTIDAD DE PERSONAS NECESARIAS P/ ARMAR.



LISTA DE ACESSÓRIO / ACCESSORY LIST /
 LISTAJE DE ACCESORIO - 1X1

	A 06 911268 - PARAF. 3,5X12 CHATA CABEÇA 6,8
	B 32 907532 - PARAF. 4,0X12 CABEÇA PANELA
	C 04 909192 - PARAF. 3,5X25 CABEÇA CHATA
	D 16 903542 - PARAF. 3,5X40
	E 04 903563 - PARAF. 6,0X50
	F 45 904801 - PREGO 09X09
	G 28 902913 - CAVILHA 8X30
	H 08 902915 - CAVILHA 8X50
	I 04 904980 - SUPORTE DE PRATELEIRA
	J 04 900053 - BUCHA 08

LISTA DE ACESSÓRIO / ACCESSORY LIST /
 LISTAJE DE ACCESORIO

	K 04 903341 - FIXADOR L CANTONEIRA METÁLICA		N 02 911354 - PUXADOR 256MM ESP 15
	L 04 901635 - FIXADOR L CAPA PLÁSTICA		O 10 900456 - FIXADOR PARA FUNDO
	M 04 910610 - DOBRADIÇA BAIXA COM AMORTECEDOR		P 07 910914 - KIT C/ 2 TAPA FURO ADESIVO 13MM

**ESTRUTURA
 STRUCTURE
 ESTRUCTURA**

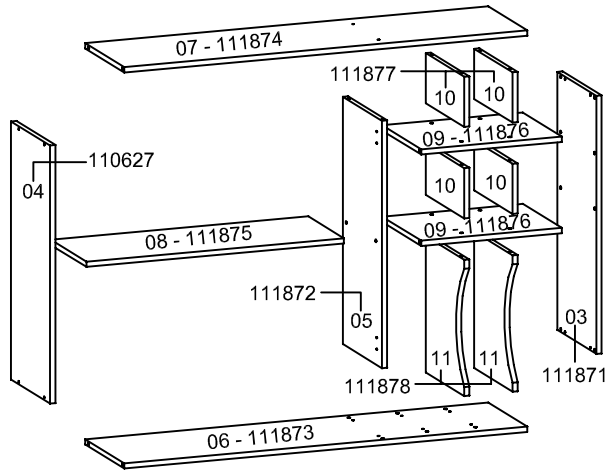

**TRASEIRO
 BOTTOM
 TRASERO**

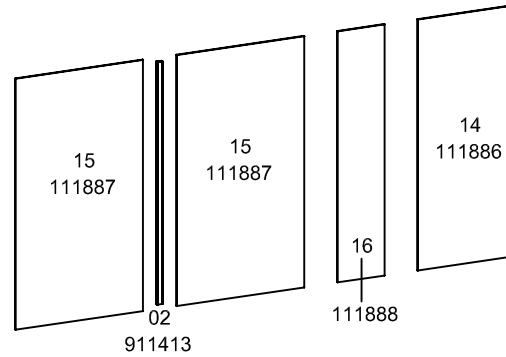

**FRENTE
 FRONT
 FRENTE**

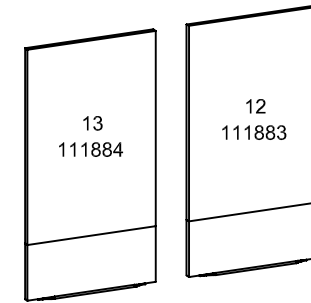

ATENÇÃO / ATTENTION / ATENCIÓN:

- A LIMPEZA DO MÓVEL DEVE SER EFETUADA SOMENTE COM PANO MACIO E MODERADAMENTE UMEDECIDO COM ÁGUA PURA OU SOLUÇÃO COM SABÃO NEUTRO.
- FOR CLEANING, USE ONLY A SOFT CLOTH MODERATELY MOISTENED WITH PURE WATER OR A SOLUTION WITH NEUTRAL SOAP.
- PARA LIMPIEZA DEL MUEBLE USAR PAÑO SUAVE Y MODERADAMENTE HUMEDECIDO CON AGUA PURA O SOLUCIÓN CON JABÓN NEUTRO.
- NÃO UTILIZE PRODUTOS QUÍMICOS OU ABRASIVOS, TAIS COMO: CERA, ÁLCOOL, DETERGENTES, TINNER.
- DO NOT USE CHEMICAL OR ABRASIVE PRODUCTS. FOR EXAMPLE: WAX, ALCOHOL, DETERGENT, THINNER.
- NO APLICAR PRODUCTOS QUÍMICOS O ABRASIVOS TAIS COMO: CERAS, ALCOOL, THINNER, DETERGENTE.
- AO SOLICITAR ASSISTÊNCIA TÉCNICA, INFORME O CÓDIGO DO PRODUTO, A COR E O CÓDIGO DA PEÇA CORRETAMENTE.
- WHEN REQUESTING TECHNICAL ASSISTENCE, INFORM THE PRODUCT CODE, THE COLOR AND THE PIECE CODE CORRECTLY.
- SI NECESITAR REPUESTOS, INFORMAR EL CÓDIGO DEL PRODUCTO, EL COLOR Y EL CÓDIGO DE LA PIEZA.

FERRAMENTAS NECESSÁRIAS P/ MONTAGEM.
 (NÃO SÃO FORNECIDAS)
 REQUIRED TOOLS FOR ASSEMBLY. (NOT PROVIDED)
 HERRAMIENTAS NECESSARIAS.
 (NO PROPORCIONADAS)



- PARA UNIÃO DOS MÓDULOS, FAZER USO DO PARAF. 3,5X25 (C).
- FOR THE MODULES UNION, USE SCREW 3,5X25 (C).
- PARA LA UNIÓN DE LOS MÓDULOS, USE EL TORNILLO 3,5X25 (C).

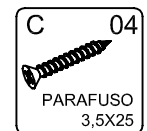
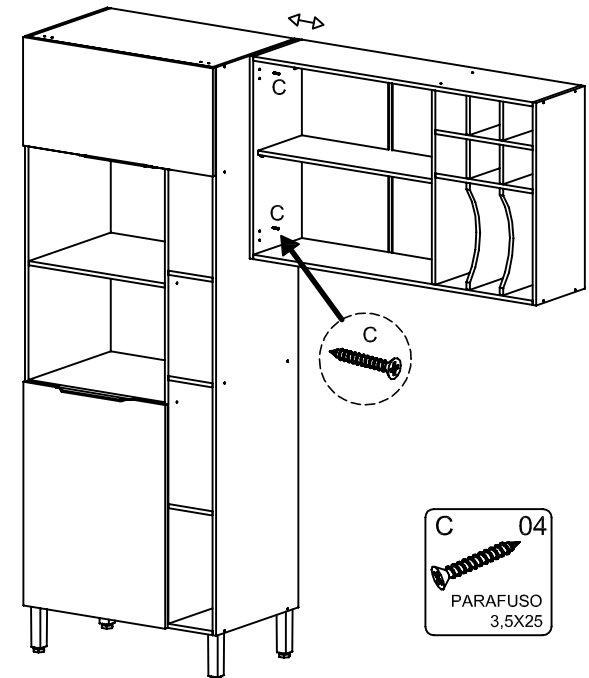

① MONTAGEM DA ESTRUTURA.
 STRUCTURE ASSEMBLY.
 MONTAJE DE LA ESTRUCTURA.

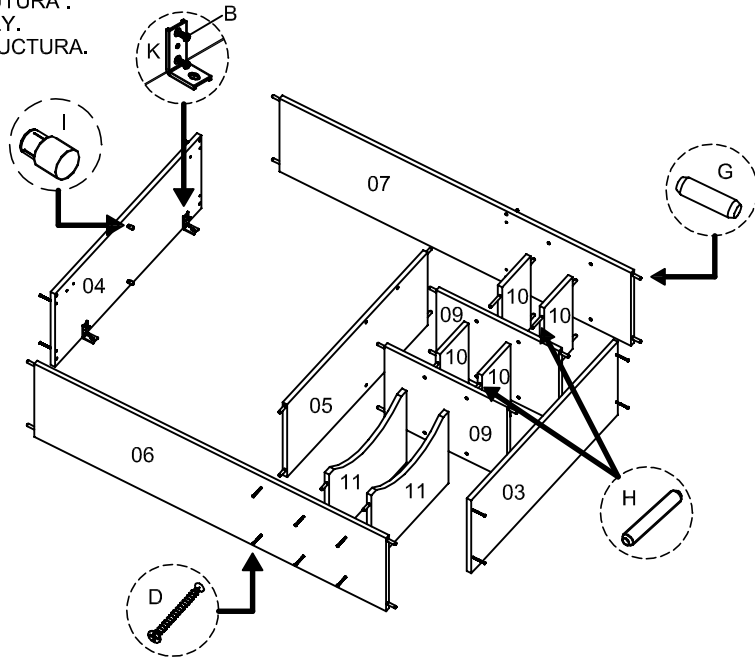
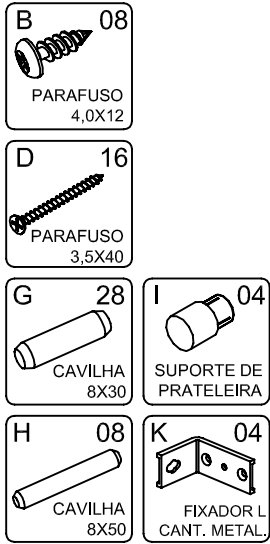

② FIXAÇÃO DOS TRASEIROS.
 BOTTOMS ATTACHMENT.
 FIJACIÓN DE LOS TRASEROS.

- TIRAR ESQUADRO:
 MEDIR EM CRUZ PELOS
 CANTOS DO PRODUTO.
 - SQUARING: MEASURE
 THE OPPOSITE CORNERS
 OF THE PRODUCT IN
 CROSSWISE.
 - ESCUADRAR: TOMAR LA
 MEDIDA ENTRE LAS
 EXTREMIDADES INVERSAS
 DEL PRODUCTO.

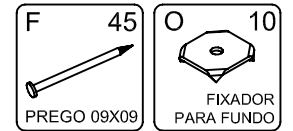
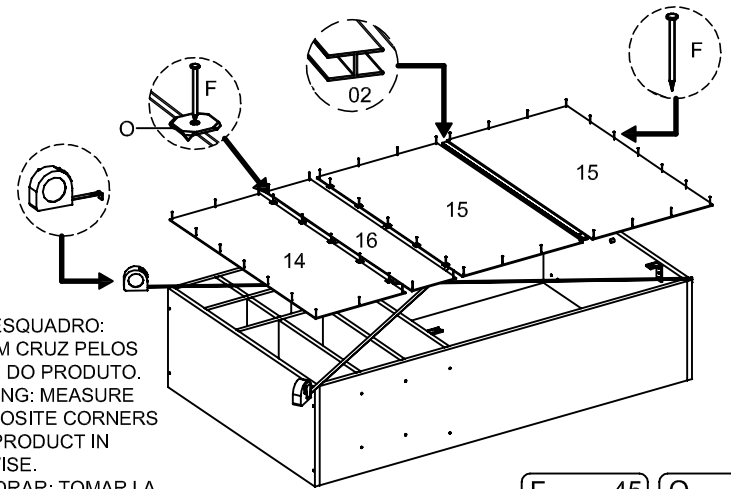

③ COLOCAÇÃO DAS PORTAS E PRATELEIRA I.
 DOORS AND SHELF I PLACEMENT.
 COLOCACIÓN DE LAS PUERTAS Y REPISA I.

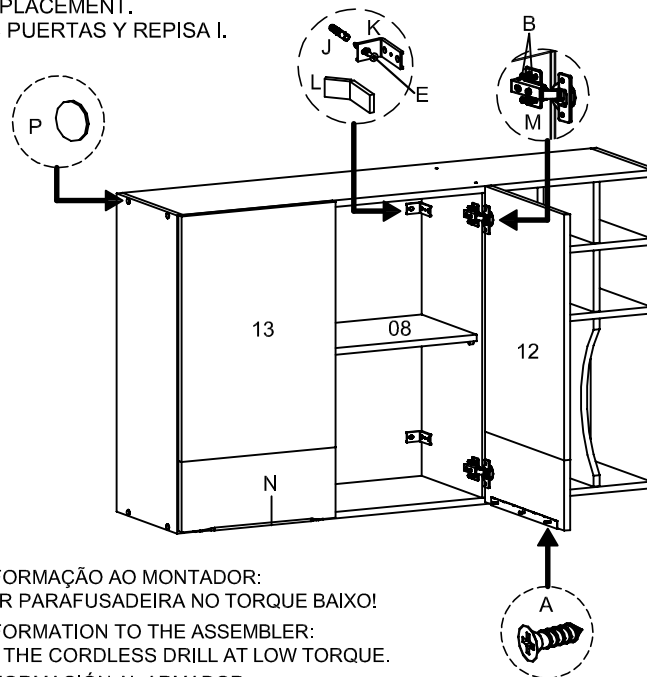
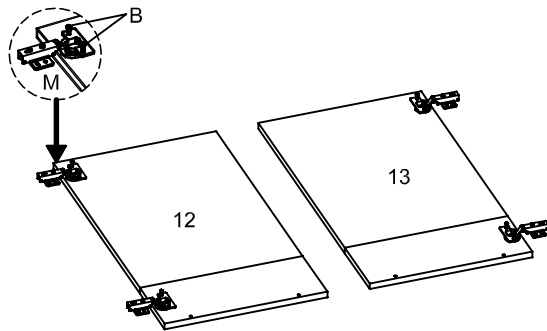

* LIMITE DE PESO MÁXIMO SUPORTADO (KG).
 * WEIGHT CAPACITY (KG).
 * CAPACIDAD DE PESO (KG).

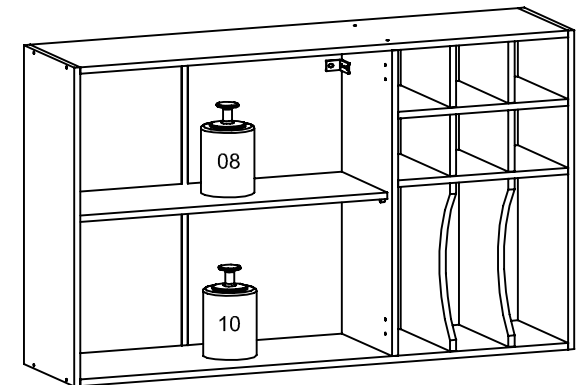

- CONSIDERAR UM PESO BEM DISTRIBUÍDO
 POR TODO O PRODUTO.
 - CONSIDER A WELL DISTRIBUTED WEIGHT
 IN ALL THE PRODUCT.
 - CONSIDERAR UN PESO BIEN DISTRIBUIDO
 EN TODO EL PRODUCTO.

- INFORMAÇÃO AO MONTADOR:
 USAR PARAFUSADEIRA NO TORQUE BAIXO!
 - INFORMATION TO THE ASSEMBLER:
 USE THE CORDLESS DRILL AT LOW TORQUE.
 - INFORMACIÓN AL ARMADOR:
 UTILIZAR ATORNILLADOR EN TORQUE FLACO.

