

Torre Quente 01 Fornos Essência | Torre caliente 01 Horno Essência | 01 Hot Essência Tower furnace C564-134 Areia HP/Nature

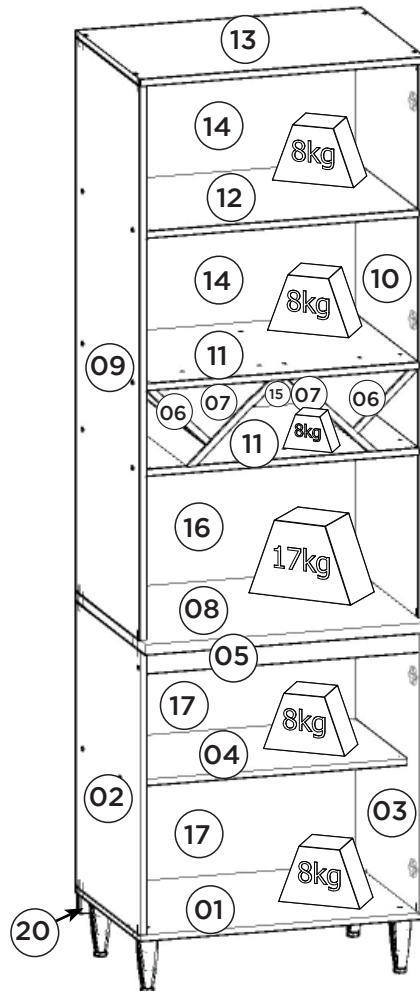

Pesos máximos recomendados com carga distribuída
Peso máximo recomendado con la carga distribuída
Recommended maximum weights with evenly distributed.

Requisitos para montagem Requisitor para la montaje Assembly Requirements

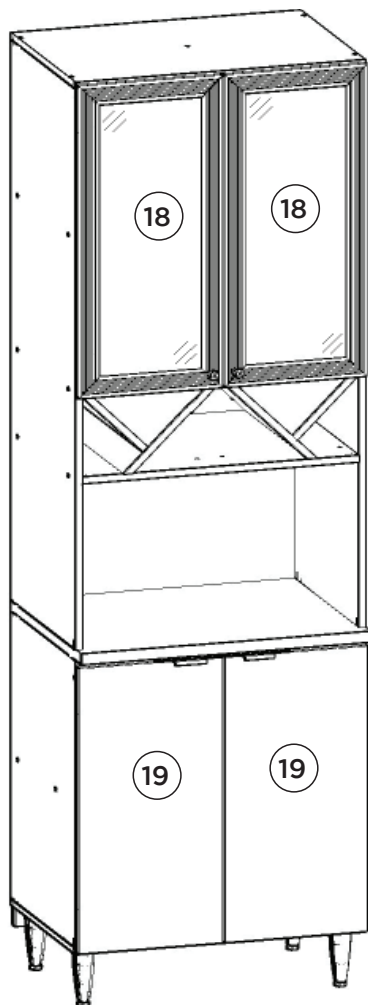
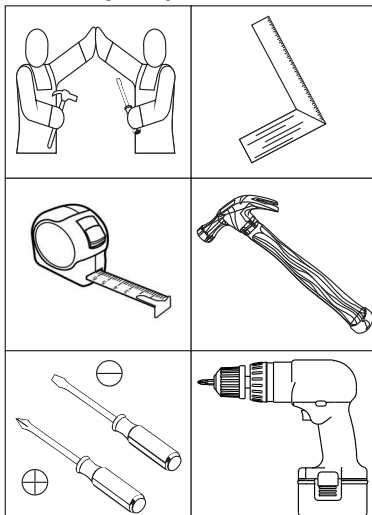

Imagens meramente ilustrativas
Imágenes meramente ilustrativas
Images for illustration only

AVISO

Para limpeza de seu móvel, use uma flanela seca ou umedecida, e não utilize produtos químicos que possam danificar seu produto.

SISTEMA DE MONTAGEM

O sistema de montagem dos produtos, funciona de acordo com a ordem crescente dos números indicados no desenho. Ex: 01, 02, 03, 04... até a conclusão da montagem.

ADVERTENCIA

Para limpieza de su móvil, use una flanela seca o húmeda, y no utilice productos químicos que puedan dañar su producto.

SISTEMA DE MONTAJE

El sistema de montaje de los productos funciona de acuerdo con el orden creciente de los números indicados en el dibujo. Ej.: 01, 02, 03, 04... hasta la conclusión del montaje.

NOTICE

To clean your furniture, use a dry or wet cloth, and do not use chemicals that may damage your product.

ASSEMBLY SYSTEM

The products' assembly system works according to the increasing order of the indicated numbers. For example: 01, 02, 03, 04 ... to the end of the assembly.

1º

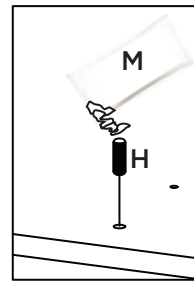

Utilizar o sachê de cola (M) em todas as cavilhas (H) do produto.

Con el pegamento sobre (M) en todos los pernos (H) producto.

Use the glue sachet (M) on all the pegs (H) of the product.

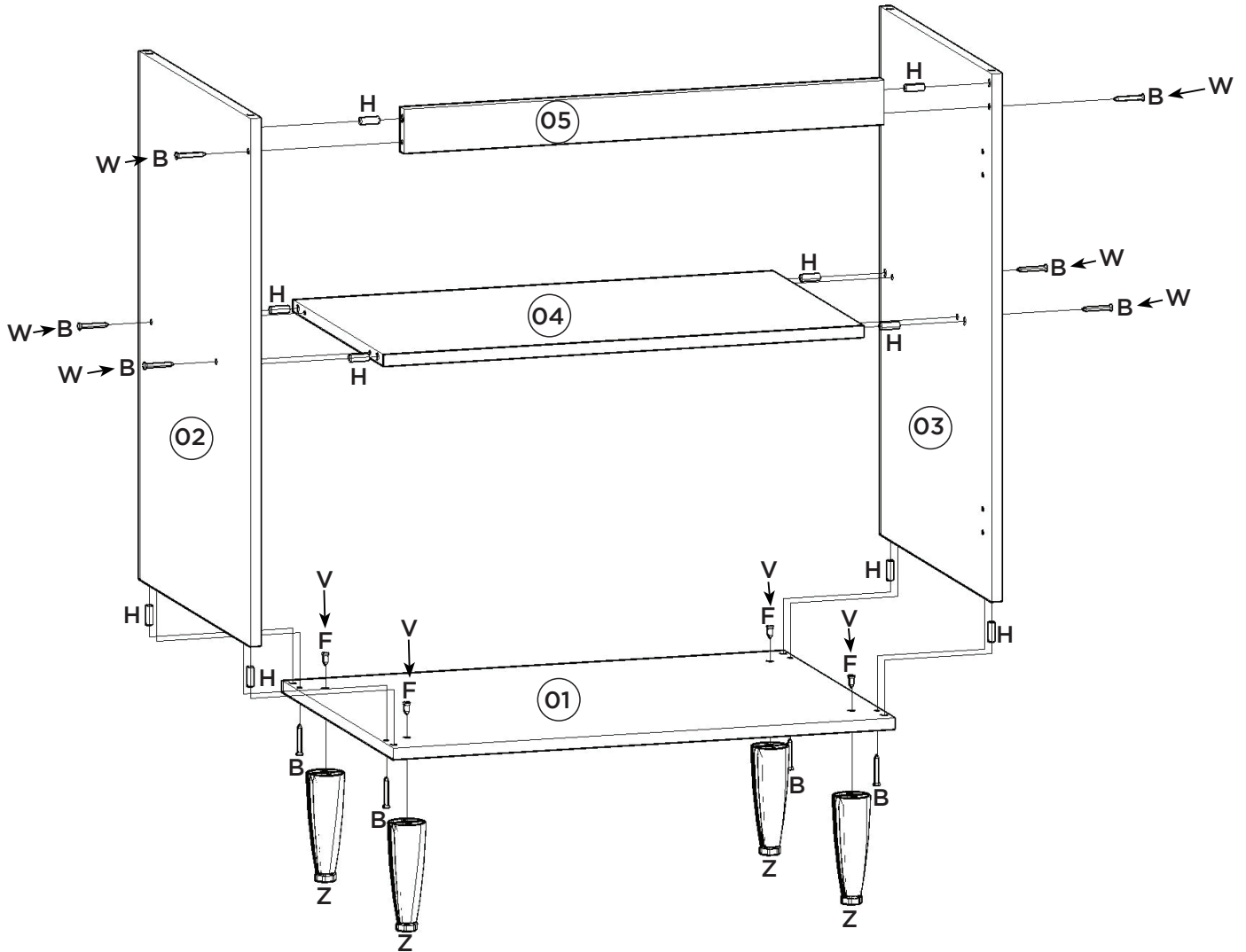

2º

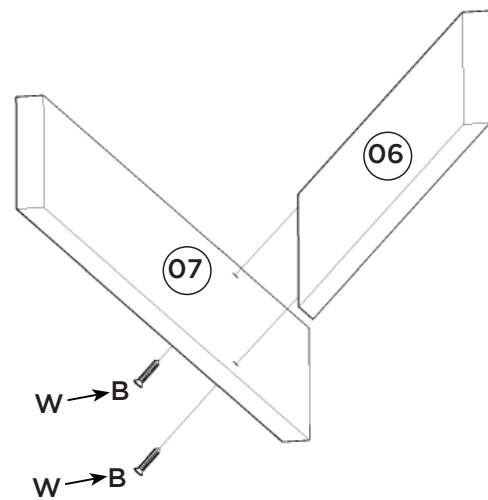
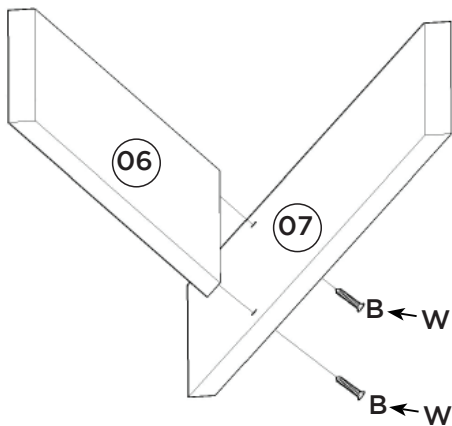

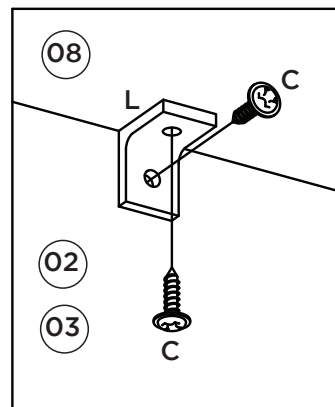
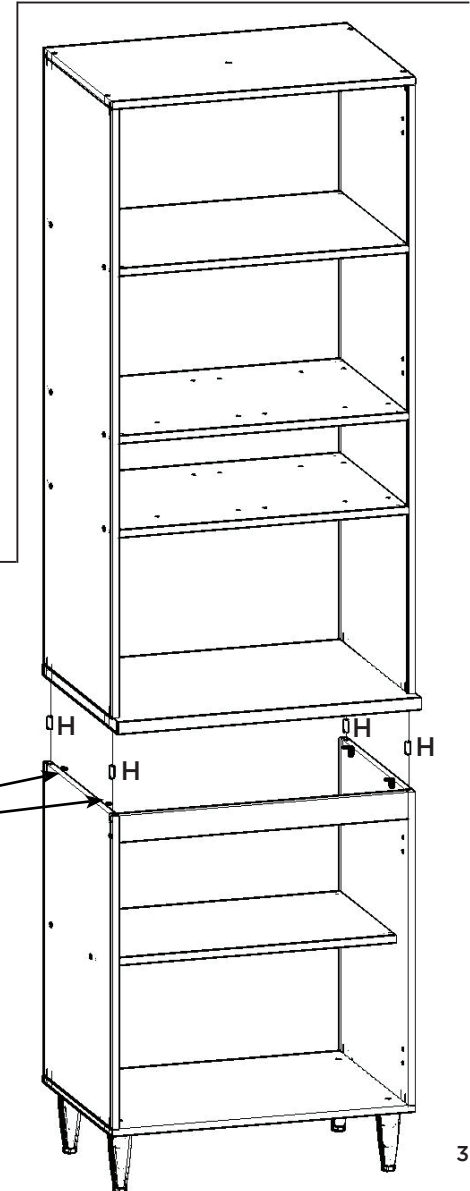
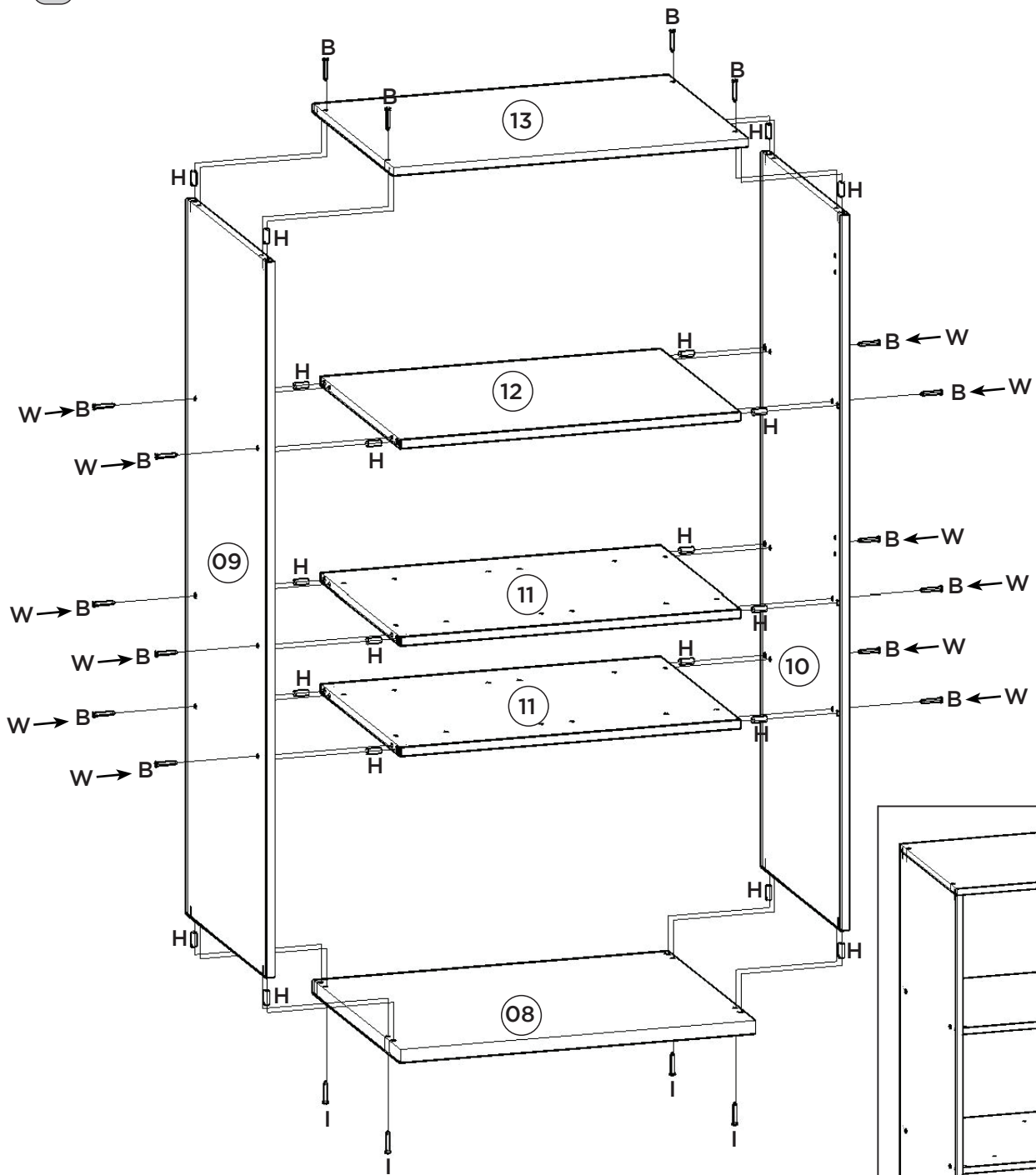

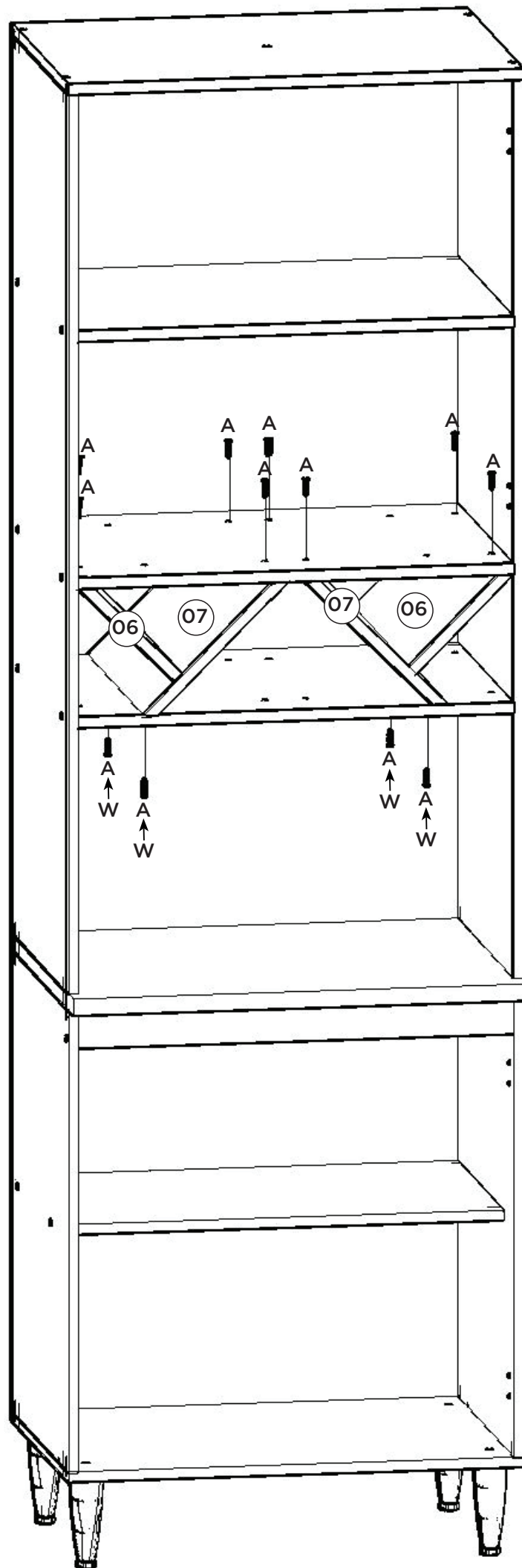

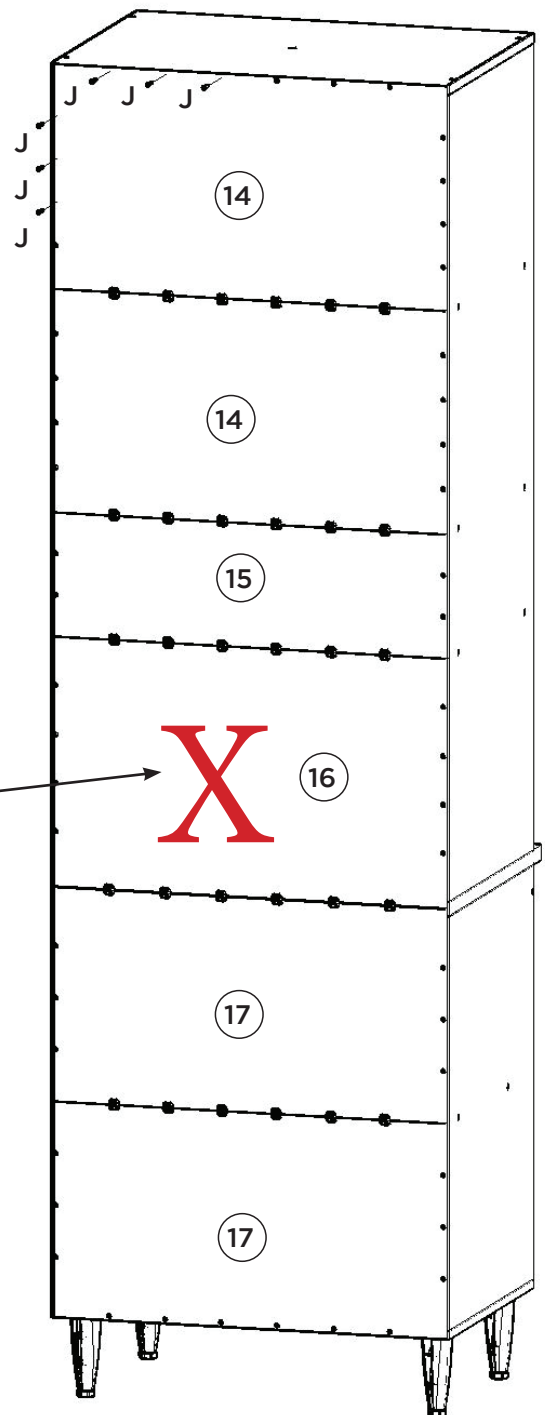

ATENÇÃO: Por questão de segurança, recomendamos a não utilização dos Fundos (16) caso o espaço seja utilizado por forno elétrico ou forno embutido, dessa forma, haverá melhor propagação do calor, evitando danos em seu móvel.

ATENCIÓN: Por razones de seguridad, recomendamos la no utilización de los Fondos (16) en caso de que el espacio sea utilizado por horno eléctrico o horno embutido, de esa forma, habrá mejor propagación del calor, evitando daños en su mueble.

WARNING: For safety reasons, we recommend that you do not use the bottoms (16) if the space is used by an electric oven or built-in oven, in this way, there will be better propagation of the heat, avoiding damage to your furniture.

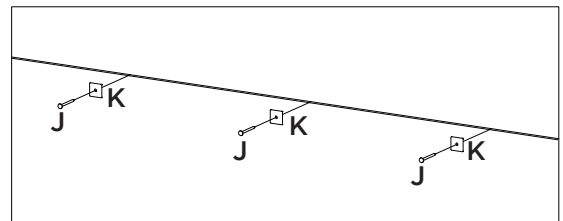

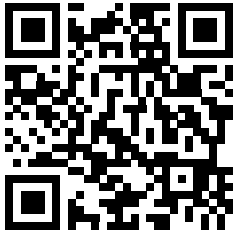
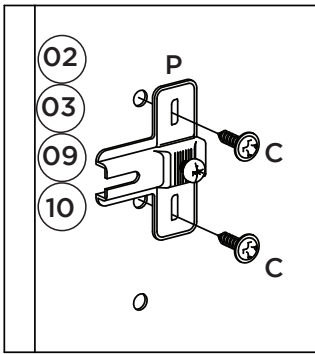
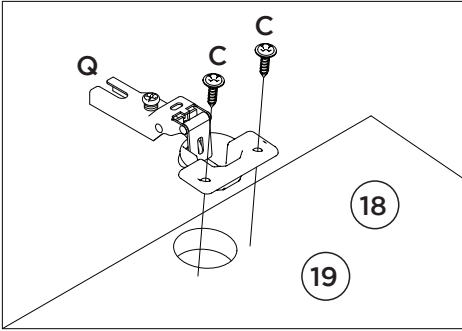
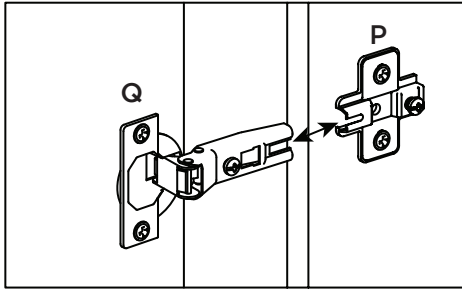

Vídeo: Instalar e regular Dobradiças

Video: Instale y ajuste las bisagras

Video: Install and adjust hinges

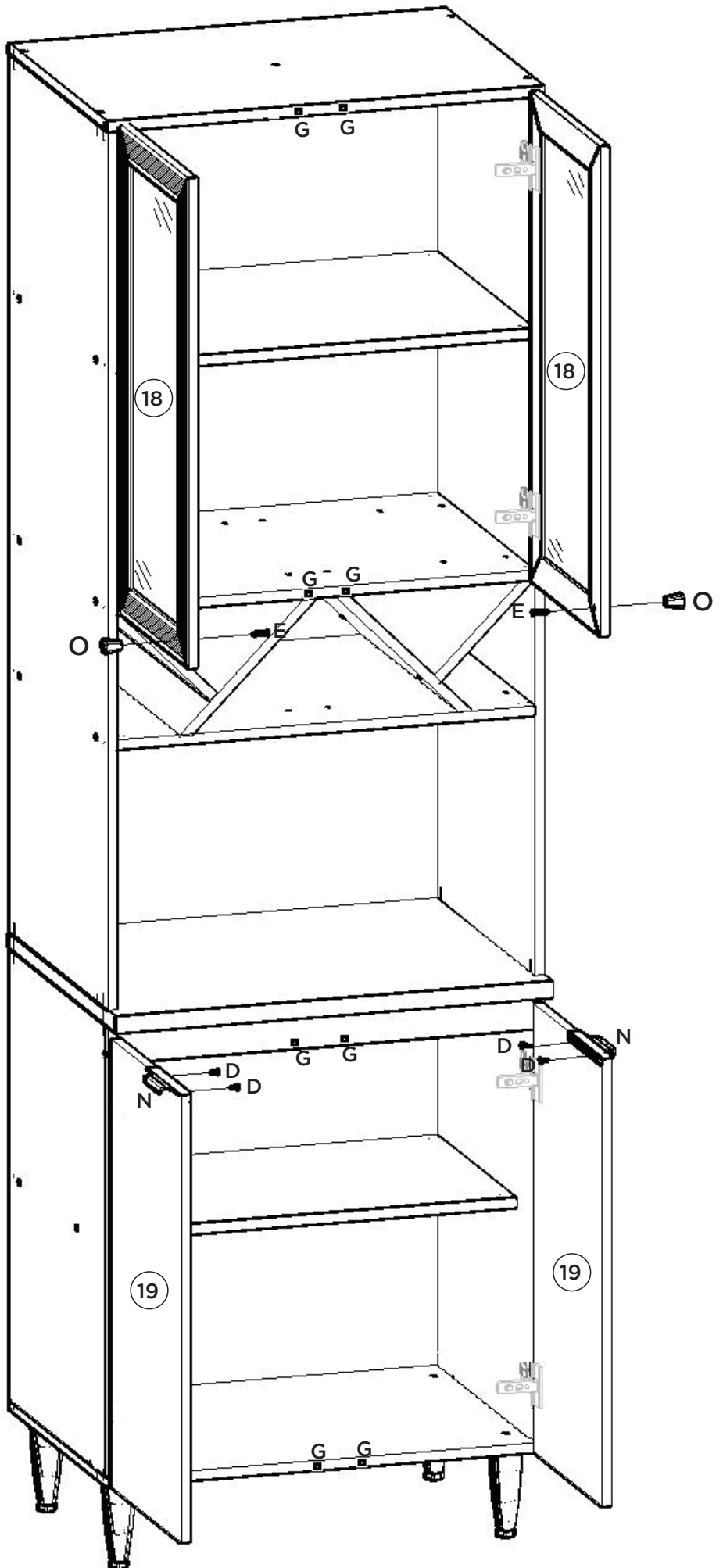

Opção Suspensa

Opción suspendida



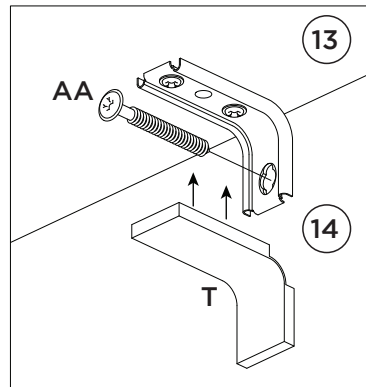
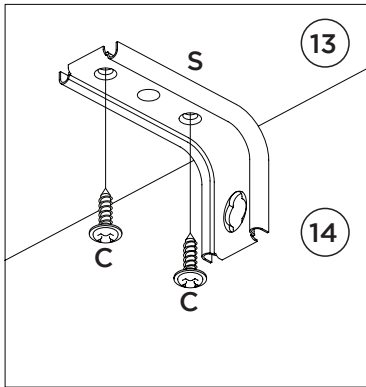
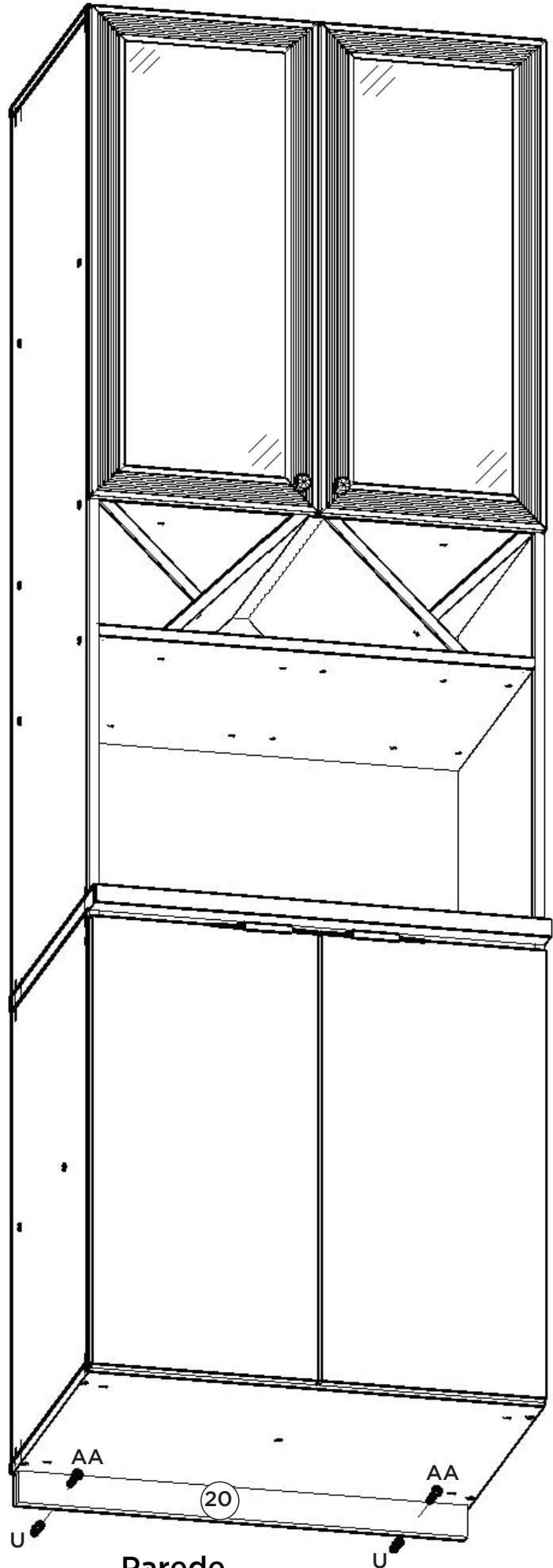







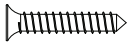







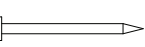





Suspended Option



Parede
pared
Wall

Item	Caixa Caja Box	Qtd Ctd Qty	Descrição Descripción Description	Medidas (mm) Dimensions (mm) Size (measurements) (mm)
01	2/2	01	Base Base Base	700x490x15
02	1/2	01	Lateral Esquerda Inferior Lateral Izquierda Inferior Left Side Lower	715x490x15
03	1/2	01	Lateral Direita Inferior Lateral Derecha Inferior Right Side Lower	715x490x15
04	1/2	01	Prateleira Inferior Estantería Inferior Shelf Lower	669x400x15
05	1/2	01	Travessa frontal Travesaño frontal Front crossbar	669x60x15
06	2/2	02	Travessa Menor Chanfrada Fuente Menor Biselada Beveled Minor Platter	488x212x15
07	2/2	02	Travessa Nicho Chanfrada Bandeja de nicho biselada Beveled Niche Platter	488x298x15
08	2/2	01	Tampo 25mm Tapa 25mm 25mm Top	700x533x25
09	1/2	01	Lateral Esquerda Superior Lateral Izquierda Superior Upper Left Side	1390x490x15
10	1/2	01	Lateral Direita Superior Lateral Derecha Superior Right Side Superior	1390x490x15
11	2/2	02	Prateleira Nicho Estantería Nicho Niche Shelf	669x490x15
12	2/2	01	Prateleira Estantería Shelf	669x490x15
13	2/2	01	Tampo Tapa Top	700x490x15
14	2/2	02	Fundo Superior Fondo superior Superior background	693x385x3
15	2/2	01	Fundo Estreito Fondo estrecho Narrow Bottom	693x214x3
16	2/2	01	Fundo central Fondo central Central fund	693x429x3
17	2/2	02	Fundo Inferior Fondo inferior bottom Lower	693x371x3
18	1/2	02	Porta de Vidro Puerta de vidrio Glass door	775x346x15
19	1/2	02	Porta Puerta Door	710x346x15
20	1/2	01	Travessa Sustentação Placa de soporte Support Plate	690x50x15

Ferragens | Herrajes | Hardware

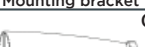
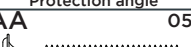
A 12x  Parafuso 4,0x25mm CHT. Tornillo 4,0x25mm CHT. Screw 4,0x25mm CHT.	B 30x  Parafuso 3,5x40mm CHT. Tornillo 3,5x40mm CHT. Screw 3,5x40mm CHT.	C 46x  Parafuso 3,5x14mm FLA. Tornillo 3,5x14mm FLA. Screw 3,5x14mm FLA.	D 04x  Parafuso 3,5x12mm CHT. Tornillo 3,5x12mm CHT. Screw 3,5x12mm CHT.	E 02x  Parafuso 3,5x25mm FLA. Tornillo 3,5x25mm FLA. Screw 3,5x25mm FLA.	F 04x  Parafuso 7,0x40mm CHT. Tornillo 7,0x40mm CHT. Screw 7,0x40mm CHT.	G 08x  Batente PVC para Porta Parada de PVC para Puerta PVC Door Stop
H 34x  Cavilha 8x25mm Cinta 8x25mm Dowel 8x25mm	I 04x  Parafuso 4,5x50mm CHT. Tornillo 4,5x50mm CHT. Screw 4,5x50mm CHT.	J 93x  Prego 10x10mm Clavo 10x10mm Nail 10x10mm	K 35x  Fixador de fundos Fijador de fondos Bottom fixer	L 04x  Cantoneira plástica Cantonera plástica Plastic angle brackets	M 01x  Sachê de cola Bolsa de pegamento Glue bag	N 02x  Puxador PV392 160mm Tirador PV392 160mm PV392 Handle 160mm
O 02x  Puxador Pontual Diamante Tirador de punta de diamante Diamond Point Handle	P 08x  Calço metal alto 3mm Calzado metálico alto 3mm 3mm high metal chock	Q 08x  Dobradiça metal 35mm Colo Baixo Bisagra de metal 35mm Colo Bajo Metal hinge 35mm Colo Low	R 04x  Parafuso União 30mm Tornillo Unión 30mm Union Screw 30mm	S 03x  Suporte de fixação Soporte de fijación Mounting bracket	T 03x  Proteção para cantoneira Ángulo de protección Protection angle	U 05x  Buchta plástica 8mm Buchta de plástico 8mm 8mm plastic bushing
V 04x  Adesivo tampa parafuso 17mm Adhesivo tapón de tornillo 17mm Bolt cover adhesive 17mm	W 30x  Adesivo tampa parafuso 10mm Adhesivo tapón de tornillo 10mm Bolt cover adhesive 10mm	X 01x  Etiqueta resinada Henn Etiqueta resinada Henn Henn resin label	Y 03x  Giz de correção Tiza de corrección Chalk of correction	Z 04x  Pé Cônico 145mm Pie Cónico 145mm Conical Foot 145mm	AA 05x  Parafuso 5,0x50mm FLA. Tornillo 5,0x50mm FLA. Screw 5,0x50mm FLA.	



O parafuso (R) deve ser usada somente quando este módulo for acoplado a outro módulo componível Henn.



El tornillo (R) se debe utilizar sólo cuando el módulo está conectado a otro módulo componible Henn.



The screw (R) should be used only when this module is attached to another Henn modular module.

RECOMENDAÇÃO

Para fixar o móvel na parede usar o suporte de fixação (S), o parafuso 3,5x14mm FLA (C), a Bucha 8mm (U) e o parafuso 5,0x50mm FLA (A).

RECOMENDACIÓN

Para conectar el móvil a la pared con el soporte (S), tornillo 3,5 x14mm FLA (C), el casquillo de 8 mm (U) y el 5,0 x50mm tornillo FLA (A).

RECOMMENDATION

To fix the furniture to the wall use the mounting bracket (S), the 3.5x14mm FLA (C) screw, the 8mm bushing (U) and the 5.0x50mm FLA screw (A).



Ind. e Com. de Móveis Henn
Mondaí - SC - Brasil

+55 49 3674.3500

@moveishenn
www.henn.com.br

INSTRUÇÕES DE MONTAGEM

INSTRUCCIONES DE MONTAJE
ASSEMBLY INSTRUCTIONS

Aéreo 02 Portas 800mm Essência | Aéreo 02 Puertas 800mm Essência | Aerial 02 doors 800mm Essência

Referência/Cor
c C553-133 Areia HP

Requisitos para montagem
Requisitos para la montaje
Assembly Requirements

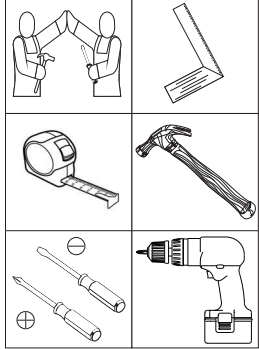

Imagens meramente ilustrativas
Imágenes meramente ilustrativas
Images for illustration only

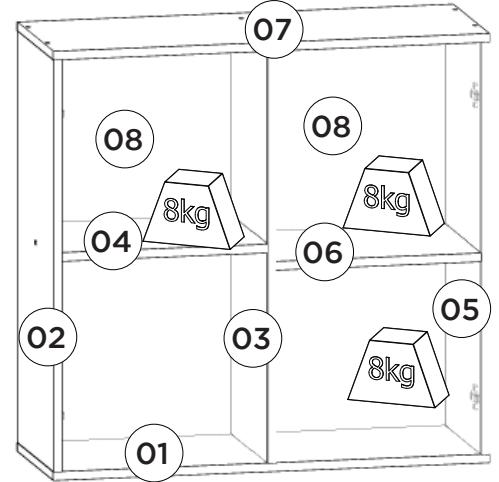
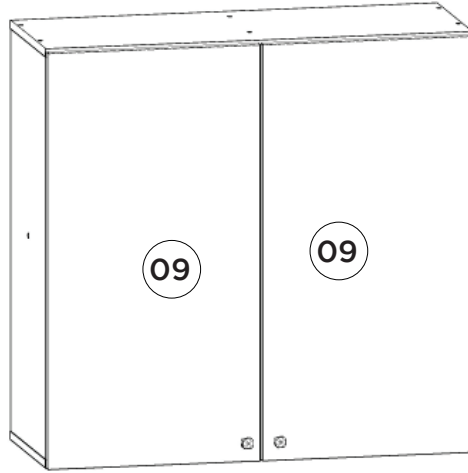

Pesos máximos recomendados com carga distribuída
Peso máximo recomendado con la carga distribuída
Recommended maximum weight with distributed load.

Lista de Peças | Lista de piezas | List of parts

Item	Caixa Caja Box	Qtd Ctd Qty	Descrição Descripción Description	Medidas (mm) Dimensions (mm) Size (measurements) (mm)
01=07	1/1	01	Base tampo Base cubierta Base top	800x295x15
02=05	1/1	01	Lateral Direita Esquerda Lateral Derecha Izquierda Right Side Left	750x295x15
03	1/1	01	Divisão División Division	750x295x15
04=06	1/1	01	Prateleira Estante Shelf	377x295x15
05=02	1/1	01	Lateral Direita Esquerda Lateral Derecha Izquierda Right Side Left	750x295x15
06=04	1/1	01	Prateleira Estante Shelf	377x295x15
07=01	1/1	01	Base tampo Base cubierta Base top	800x295x15
08	1/1	02	Fundo Fondo Bottom	774x396x3
09	1/1	02	Porta Puerta Door	775x396x15

Ferragens | Herrajes | Hardware

A Parafuso 5,0x50mm FLA. Tornillo 5,0x50mm FLA. Screw 5,0x50mm FLA.	B Parafuso 3,5x40mm CHT. Tornillo 3,5x40mm CHT. Screw 3,5x40mm CHT.	C Parafuso 3,5x14mm FLA. Tornillo 3,5x14mm FLA. Screw 3,5x14mm FLA.	D Parafuso 3,5x25mm FLA. Tornillo 3,5x25mm FLA. Screw 3,5x25mm FLA.	E Cavilha 8x25mm Cinta 8x25mm Dowel 8x25mm	F Prego 10x10mm Clavo 10x10mm Nail 10x10mm	G Fixador de fundos Fijador de fondos Bottom fixer	H Batente PVC para Porta Parada de PVC para Puerta PVC Door Stop
I Calço metal alto 3mm Calzado metálico alto 3mm 3mm high metal chock	J Dobradiça metal 35mm baixo Bisagras metálicas 35mm bajo Metal hinge 35mm low	K Puxador Pontual Diamante Tirador de punta de diamante Diamond Point Handle	L Bucha plástica 8mm Bucha de plástico 8mm 8mm plastic bushing	M Suporte de fixação Soporte de fijación Mounting bracket	N Proteção para cantoneira Ángulo de protección Protection angle	O Parafuso União 30mm Tornillo Unión 30mm Union Screw 30mm	P Giz de correção Tiza de corrección Chalk of correction
Q Sachê de cola Bolsa de pegamento Glue bag	R Adesivo tapa parafuso 10mm Adhesivo tapón de tornillo 10mm Bolt cover adhesive 10mm						

O parafuso (O) deve ser usada somente quando este módulo for acoplado a outro módulo componível Henn.

El tornillo (O) se debe utilizar sólo cuando el módulo está conectado a otro módulo componible Henn.

The screw (O) should be used only when this module is attached to another Henn modular module.

RECOMENDAÇÃO

Para fixar o móvel na parede usar o suporte de fixação (M), o parafuso 3,5x14mm FLA (C), a Bucha 8mm (L) e o parafuso 5,0x50mm FLA (A).

RECOMENDACIÓN

Para conectar el móvil a la pared con el soporte (M), tornillo 3,5 x14mm FLA (C), el casquillo de 8 mm (L) y el 5,0 x50mm tornillo FLA (A).

RECOMMENDATION

To fix the furniture to the wall use the fixing bracket (M), the 3.5x14mm FLA (C) screw, the 8mm bushing (L) and the 5.0x50mm FLA screw (A).

1º

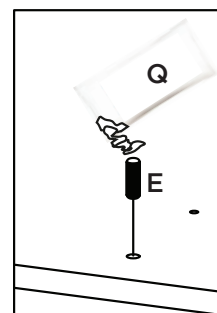
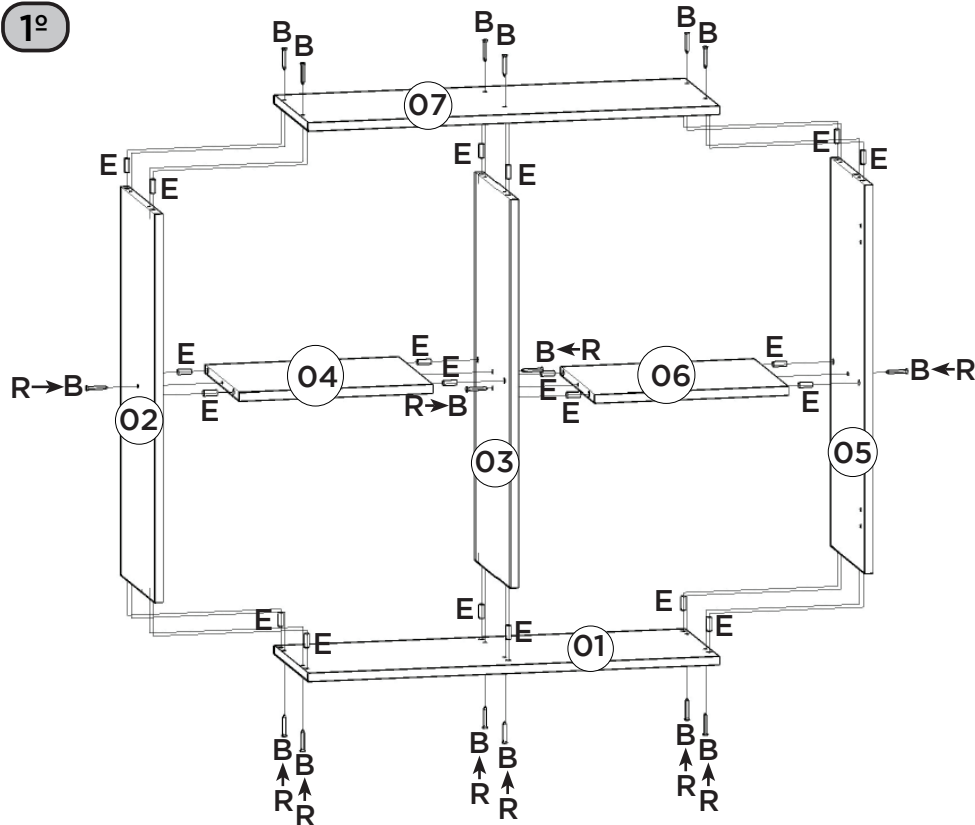

Utilizar o sachê de cola (Q) em todas as cavilhas (E) do produto.

Con el pegamento sobre (Q) en todos los pernos (E) producto.

Use the glue sachet (Q) on all the pegs (E) of the product.

AVISO

Para limpeza de seu móvel, use uma flanela seca ou umedecida, e não utilize produtos químicos que possam danificar seu produto.

SISTEMA DE MONTAGEM

O sistema de montagem dos produtos, funciona de acordo com a ordem crescente dos números indicados no desenho. Ex: 01, 02, 03, 04... até a conclusão da montagem.

ADVERTENCIA

Para limpieza de su móvil, use una flanela seca o húmeda, y no utilice productos químicos que puedan dañar su producto.

SISTEMA DE MONTAJE

El sistema de montaje de los productos funciona de acuerdo con el orden creciente de los números indicados en el dibujo. Ej.: 01, 02, 03, 04... hasta la conclusión del montaje.

NOTICE

To clean your furniture, use a dry or wet cloth, and do not use chemicals that may damage your product.

ASSEMBLY SYSTEM

The products' assembly system works according to the increasing order of the indicated numbers. For example: 01, 02, 03, 04 ... to the end of the assembly.

2º

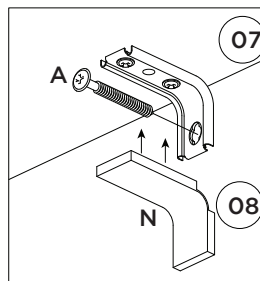
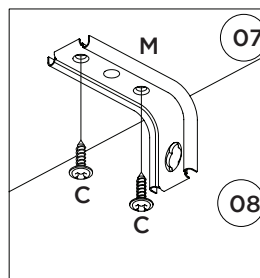
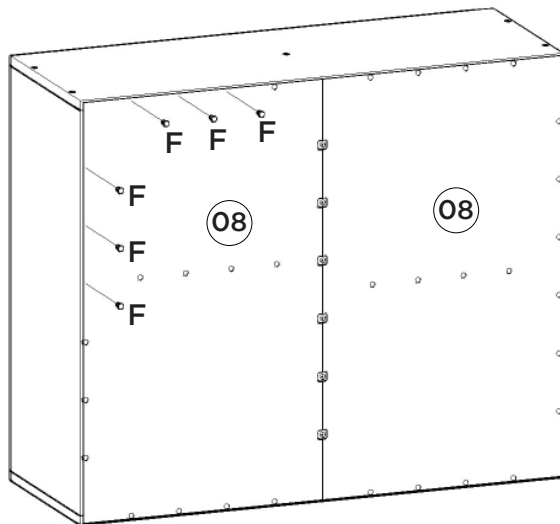
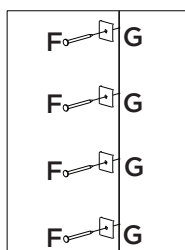

3º

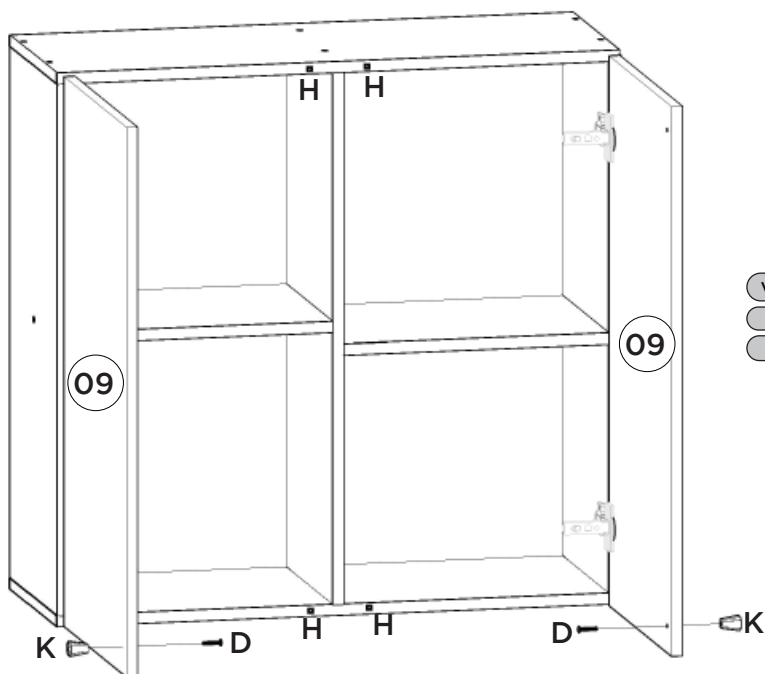

Vídeo: Instalar e regular Dobradiças

Vídeo: Instale y ajuste las bisagras

Vídeo: Install and adjust hinges

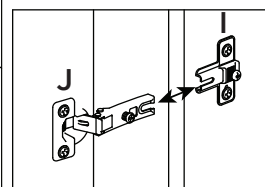
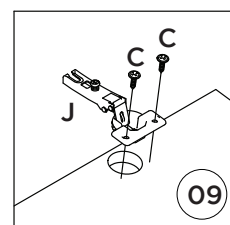
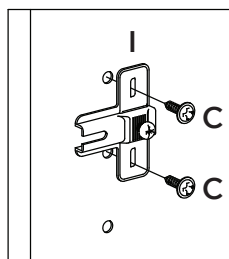

HENNInd. e Com. de Móveis Henn
Mondai - SC - Brasil

☎+55 49 3674.3500

📧@moveishenn
www.henn.com.br**INSTRUÇÕES DE MONTAGEM****INSTRUCCIONES DE MONTAJE
ASSEMBLY INSTRUCTIONS****BALCÃO 2 PORTAS 800MM ESSÊNCIA | BALCÓN 2 PUERTAS 800MM ESSÊNCIA |
BALCONY 2 DOORS 800MM ESSÊNCIA****Referência/Cor**

☐ C559-133 - Areia HP

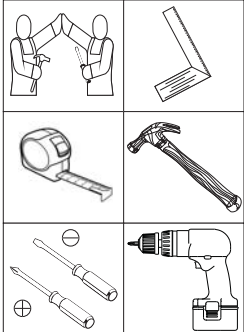
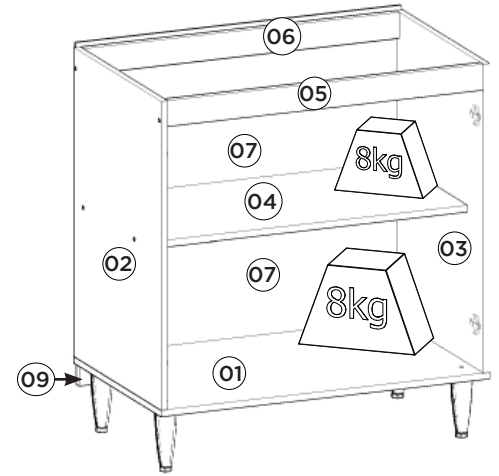
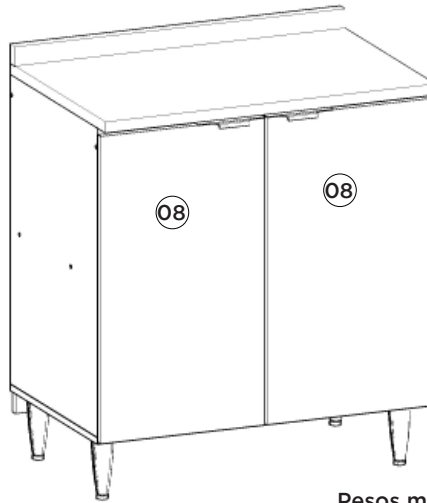
Requisitos para montagem**Requisitor para la montaje****Assembly Requirements**Imagens meramente ilustrativas
Imágenes meramente ilustrativas
Images for illustration only**Pesos máximos recomendados com carga distribuída
Peso máximo recomendado con la carga distribuida
Recommended maximum weights with evenly distributed.****Lista de Peças | Lista de piezas | List of parts**

Item	Caixa Caja Box	Qtd Ctd Qty	Descrição Descripción Description	Medidas (mm) Dimensions (mm) Size (measure- ments) (mm)
01	1/1	01	Base Base Base	800x490x15
02	1/1	01	Lateral esquerda Lateral izquierda Left side	715x490x15
03	1/1	01	Lateral direita Lateral derecha Right side	715x490x15
04	1/1	01	Prateleira Estante Shelf	769x400x15
05	1/1	01	Travessa frontal Travesaño frontal Front crossbar	769x60x15
06	1/1	01	Travessa traseira Travesaño trasero Rear bumper	769x60x15
07	1/1	02	Fundo Fondo Bottom	793x363x3
08	1/1	02	Porta Puerta Door	710x396x15
08	1/1	01	Travessa Sustentação Travessa Ayuda Support Travessa	790x50x15

AVISO

Para limpeza de seu móvel, use uma flanela seca ou umedecida, e não utilize produtos químicos que possam danificar seu produto.

SISTEMA DE MONTAGEM

O sistema de montagem dos produtos, funciona de acordo com a ordem crescente dos números indicados no desenho. Ex: 01, 02, 03, 04... até a conclusão da montagem.

ADVERTENCIA

Para limpieza de su móvil, use una flanela seca o húmeda, y no utilice productos químicos que puedan dañar su producto.

SISTEMA DE MONTAJE

El sistema de montaje de los productos funciona de acuerdo con el orden creciente de los números indicados en el dibujo. Ej.: 01, 02, 03, 04... hasta la conclusión del montaje.

NOTICE

To clean your furniture, use a dry or wet cloth, and do not use chemicals that may damage your product.

ASSEMBLY SYSTEM

The products' assembly system works according to the increasing order of the indicated numbers. For example: 01, 02, 03, 04 ... to the end of the assembly.

Ferragens | Herrajes | Hardware

A Parafuso 7,0x40mm CHT. Tornillo 7,0x40mm CHT. Screw 7,0x40mm CHT.	B Parafuso 5,0x50mm FLA. Tornillo 5,0x50mm FLA. Screw 5,0x50mm FLA.	C Parafuso 4,5x50mm CHT. Tornillo 4,5x50mm CHT. Screw 4,5x50mm CHT.	D Parafuso 3,5x40mm CHT. Tornillo 3,5x40mm CHT. Screw 3,5x40mm CHT.	E Parafuso 3,5x14mm FLA. Tornillo 3,5x14mm FLA. Screw 3,5x14mm FLA.	F Parafuso 3,5x12mm CHT. Tornillo 3,5x12mm CHT. Screw 3,5x12mm CHT.	G Parafuso União 30mm Tornillo Unión 30mm Union Screw 30mm	H Cavilha 8x25mm Cinta 8x25mm Dowel 8x25mm
I Prego 10x10mm Clavo 10x10mm Nail 10x10mm	J Fixador de fundos Fijador de fondos Bottom fixer	K Cantoneira plástica Cantenera plástica Plastic angle brackets	L Pé Cônico 145mm Pie Cónico 145mm Conical Foot 145mm	M Puxador PV392 160mm Tirador PV392 160mm PV392 Handle 160mm	N Calço metal alto 3mm Calzado metálico alto 3mm 3mm high metal chock	O Dobradiça metal 35mm Colo Baixo Bisagra de metal 35mm Colo Bajo Metal hinge 35mm Colo Low	P Batente PVC para Porta Parada de PVC para Puerta PVC Door Stop
Q Buchas plásticas 8mm Buchas de plástico 8mm 8mm plastic bushing	R Suporte de fixação Soporte de fijación Mounting bracket	S Proteção para cantoneira Ángulo de protección Protection angle	T Giz de correção Tiza de corrección Chalk of correction	U Sachê de cola Bolsa de pegamento Glue bag	V Adesivo tapa parafuso 10mm Adhesivo tapón de tornillo 10mm Bolt cover adhesive 10mm	W Adesivo tapa parafuso 17mm Adhesivo tapón de tornillo 17mm Bolt cover adhesive 17mm	

O parafuso (G) deve ser usada somente quando este módulo for acoplado a outro módulo componível Henn.

El tornillo (G) se debe utilizar sólo cuando el módulo está conectado a otro módulo componible Henn.

The screw (G) should be used only when this module is attached to another Henn modular module.

RECOMENDAÇÃO

Para fixar o móvel na parede usar o suporte de fixação (R), o parafuso 3,5x14mm FLA (E), a Bucha 8mm (Q) e o parafuso 5,0x50mm FLA (B).

RECOMENDACIÓN

Para conectar el móvil a la pared con el soporte (R), tornillo 3,5 x14mm FLA (E), el casquillo de 8 mm (Q) y el 5,0 x50mm tornillo FLA (B).

RECOMMENDATION

To fix the furniture to the wall use the mounting bracket (R), the 3.5x14mm FLA (E) screw, the 8mm bushing (Q) and the 5.0x50mm FLA (B).

1º

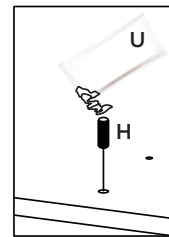
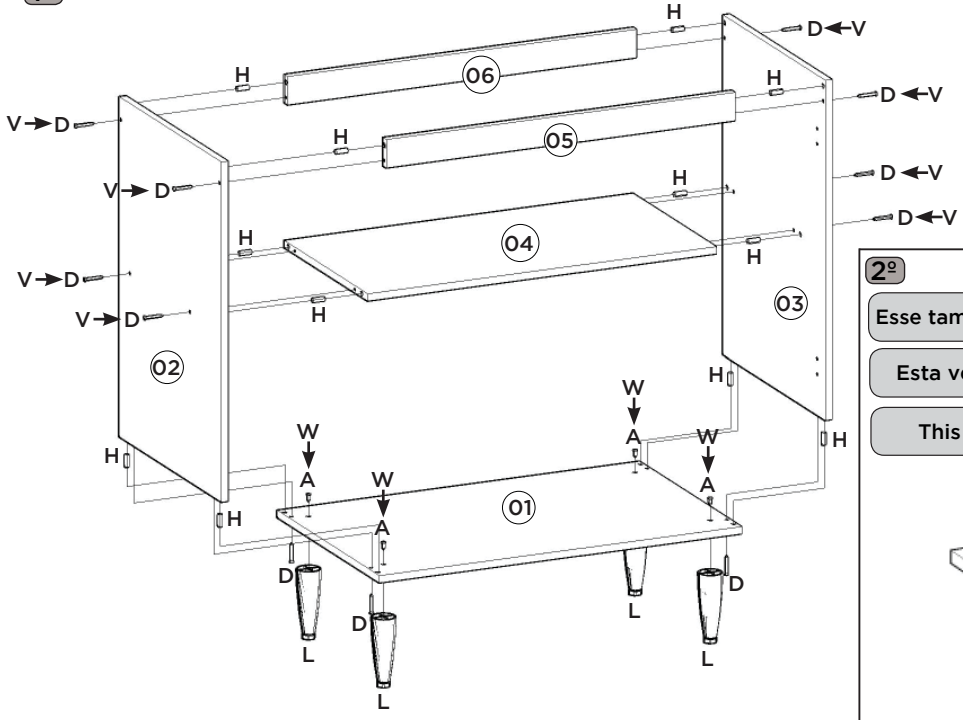

Utilizar o sachê de cola (U) em todas as cavilhas (H) do produto.

Con el pegamento sobre (U) en todos los pernos (H) producto.

Use the glue sachet (U) on all the pegs (H) of the product.

2º

Esse tampo é opcional e é vendido separadamente (C904-128).

Esta vez es opcional y se vende por separado (C904-128).

This top is optional and is sold separately (C904-128).

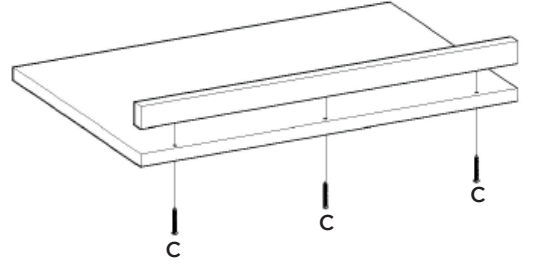

3º

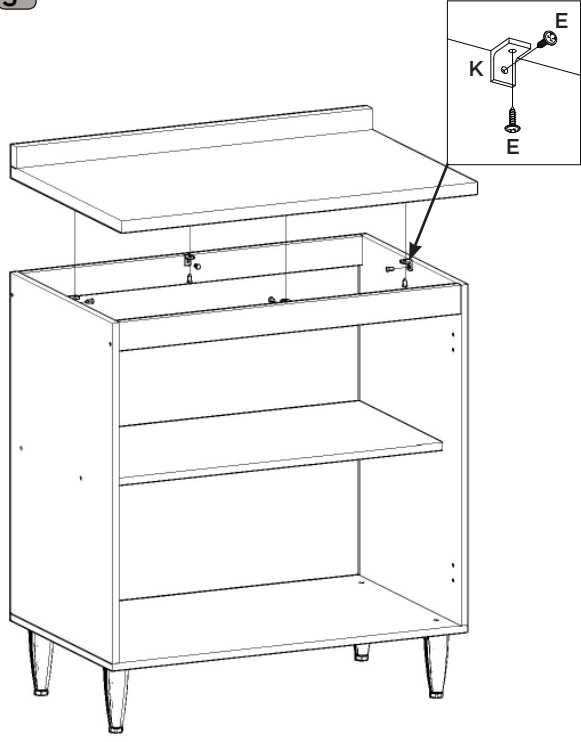

4º

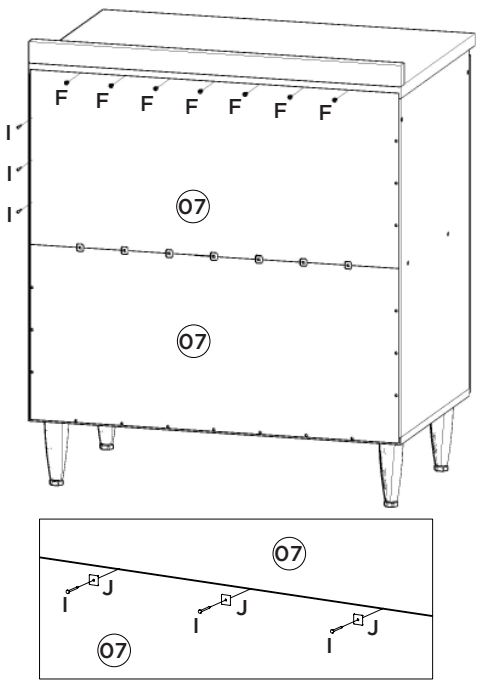

5º

Opção Suspensa Opción suspendida

Suspended Option

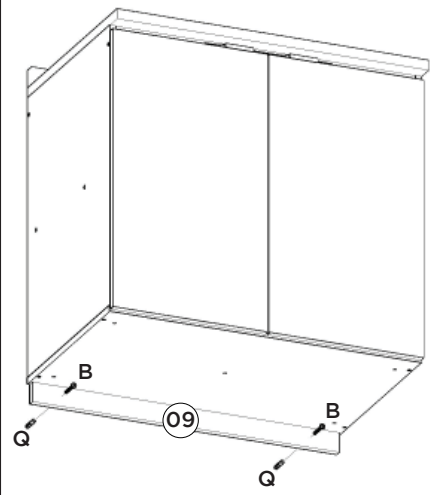

Parede
pared
Wall

6º

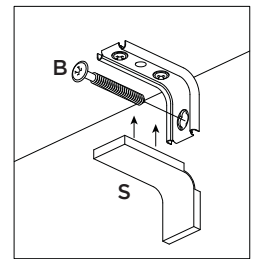
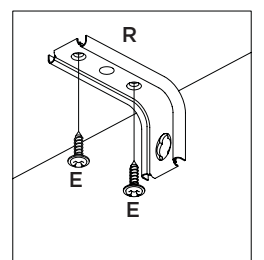
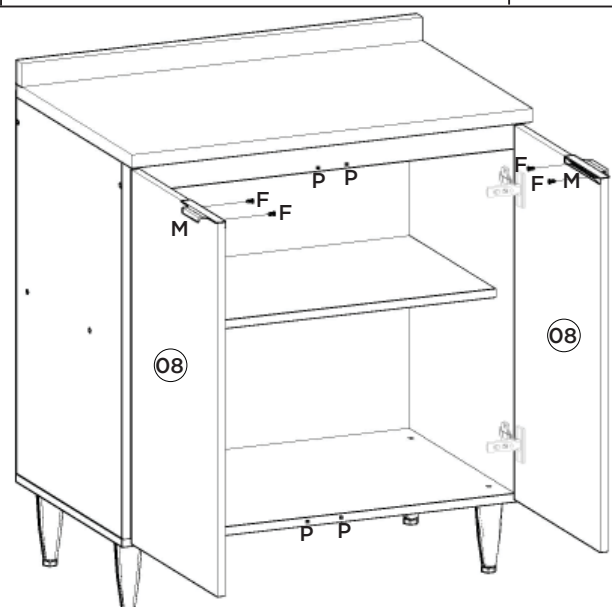
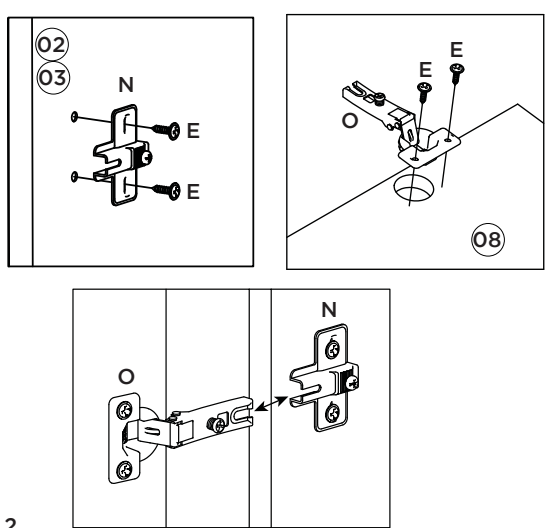

Balcão Pia 02 Portas 03 Gavetas Essência

Fregadero 02 Puertas 03 Cajones Essência | Counter Sink 02 Doors 03 Drawers Essência

C558-133 Areia HP

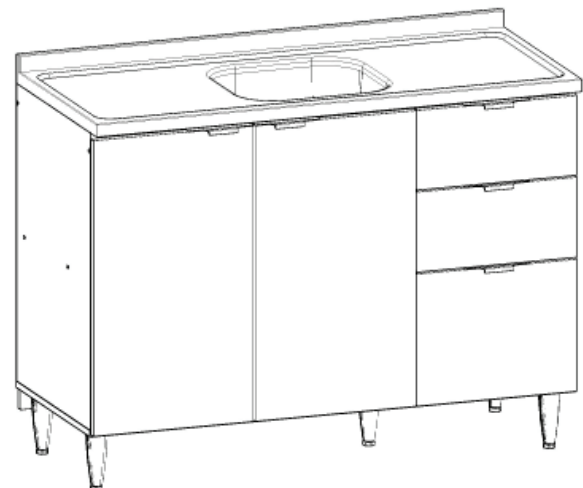
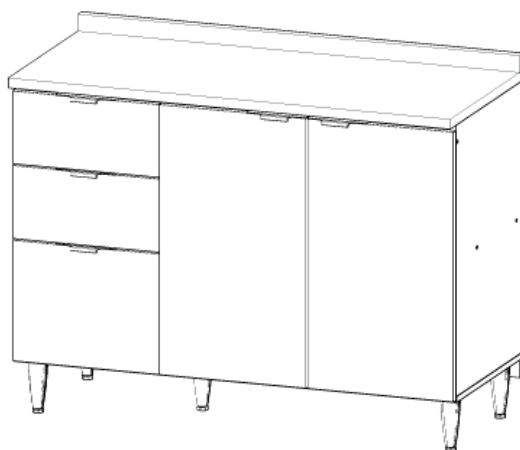
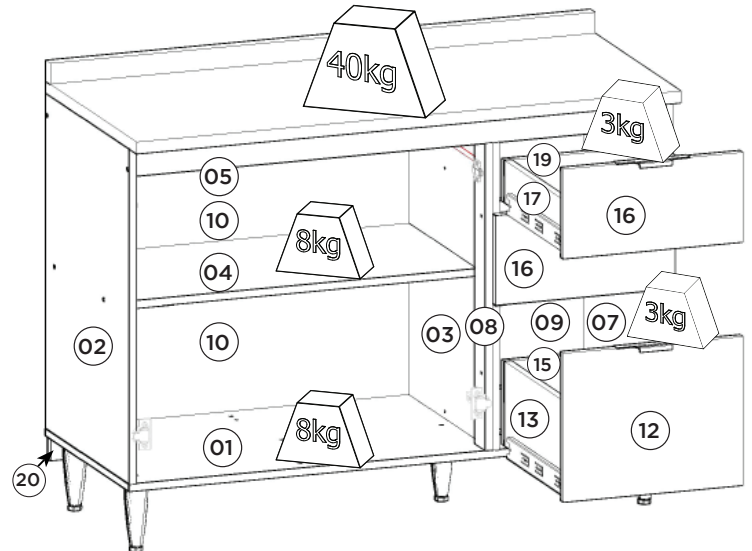
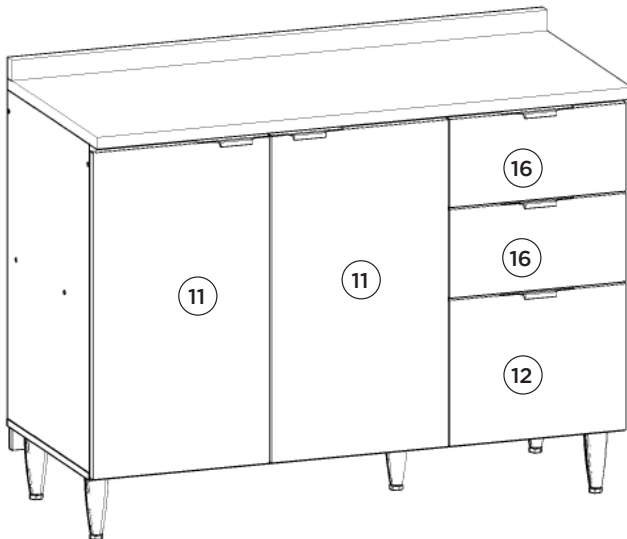

Pesos maximos recomendados com carga distribuida
Peso máximo recomendado con la carga distribuida
Recommended maximum weights with evenly distributed.

Requisitos para montagem Requisitor para la montaje Assembly Requirements

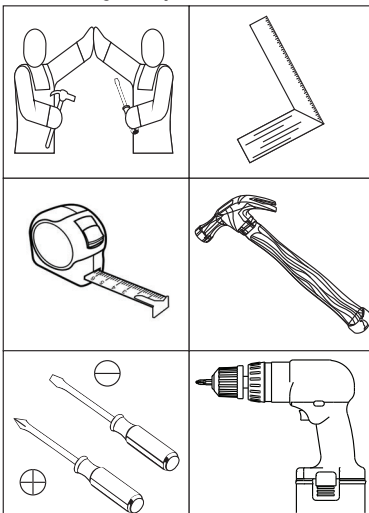

Imagens meramente ilustrativas
Imágenes meramente ilustrativas
Images for illustration only

AVISO

Para limpeza de seu móvel, use uma flanela seca ou umedecida, e não utilize produtos químicos que possam danificar seu produto.

SISTEMA DE MONTAGEM

O sistema de montagem dos produtos, funciona de acordo com a ordem crescente dos números indicados no desenho. Ex: 01, 02, 03, 04... até a conclusão da montagem.

ADVERTENCIA

Para limpieza de su móvil, use una flanela seca o húmeda, y no utilice productos químicos que puedan dañar su producto.

SISTEMA DE MONTAJE

El sistema de montaje de los productos funciona de acuerdo con el orden creciente de los números indicados en el dibujo. Ej.: 01, 02, 03, 04... hasta la conclusión del montaje.

NOTICE

To clean your furniture, use a dry or wet cloth, and do not use chemicals that may damage your product.

ASSEMBLY SYSTEM

The products' assembly system works according to the increasing order of the indicated numbers. For example: 01, 02, 03, 04 ... to the end of the assembly.

1º

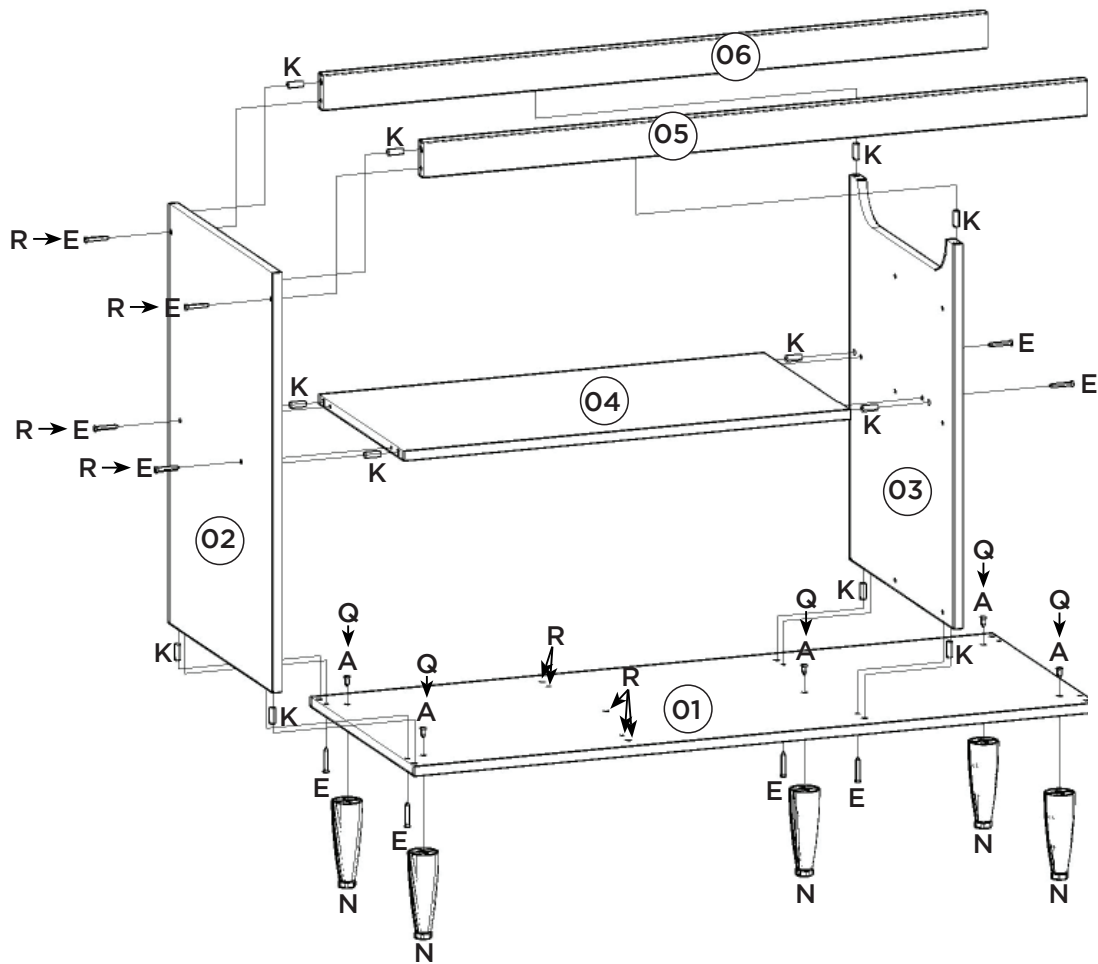

2º

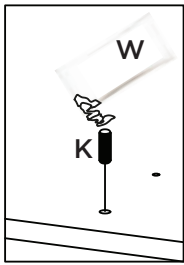

Utilizar o sachê de cola (W) em todas as cavilhas (K) do produto.

Con el pegamento sobre (W) en todos los pernos (K) producto.

Use the glue sachet (W) on all the pegs (K) of the product.

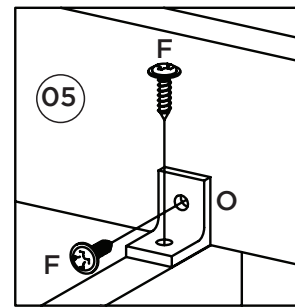

A pilastra da porta (08) deve estar alinhada com a divisão (03).

El pilar de la puerta (08) debe estar alineada con la división (03).

The door pillar (08) must be aligned with the partition (03).

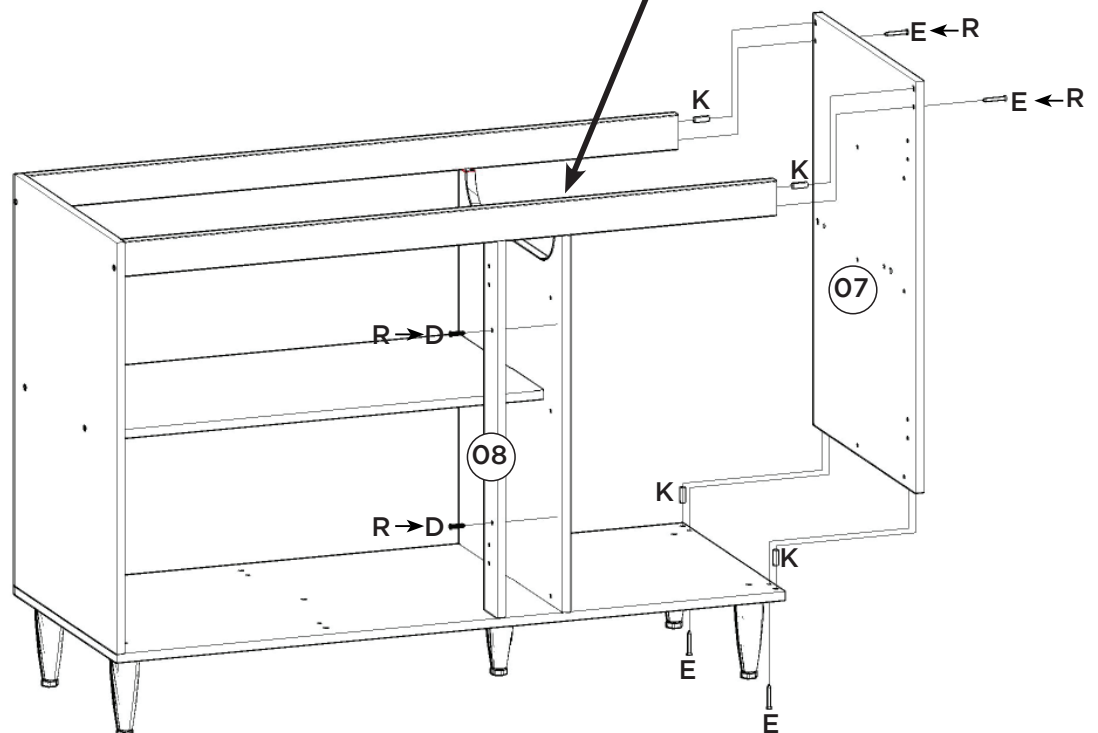

3º

Esse tampo é opcional e é vendido separadamente (C905-128).

Esta vez es opcional y se vende por separado (C905-128).

This top is optional and is sold separately (C905-128).

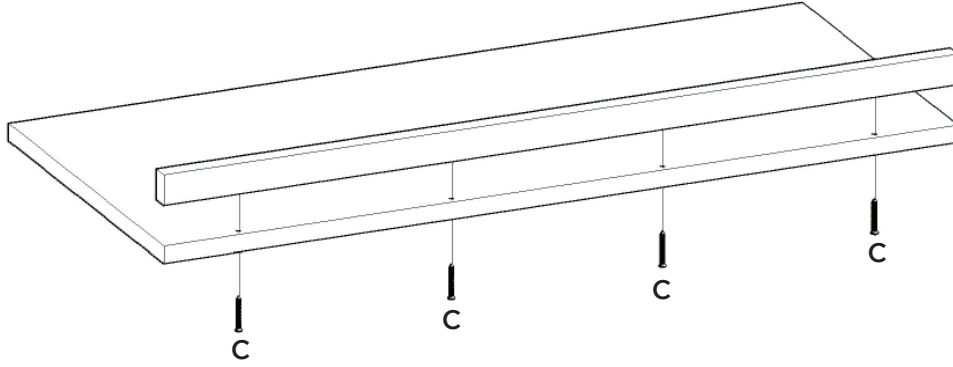

4º

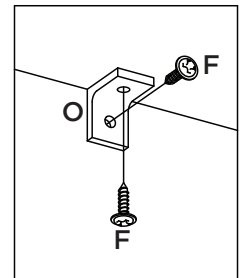
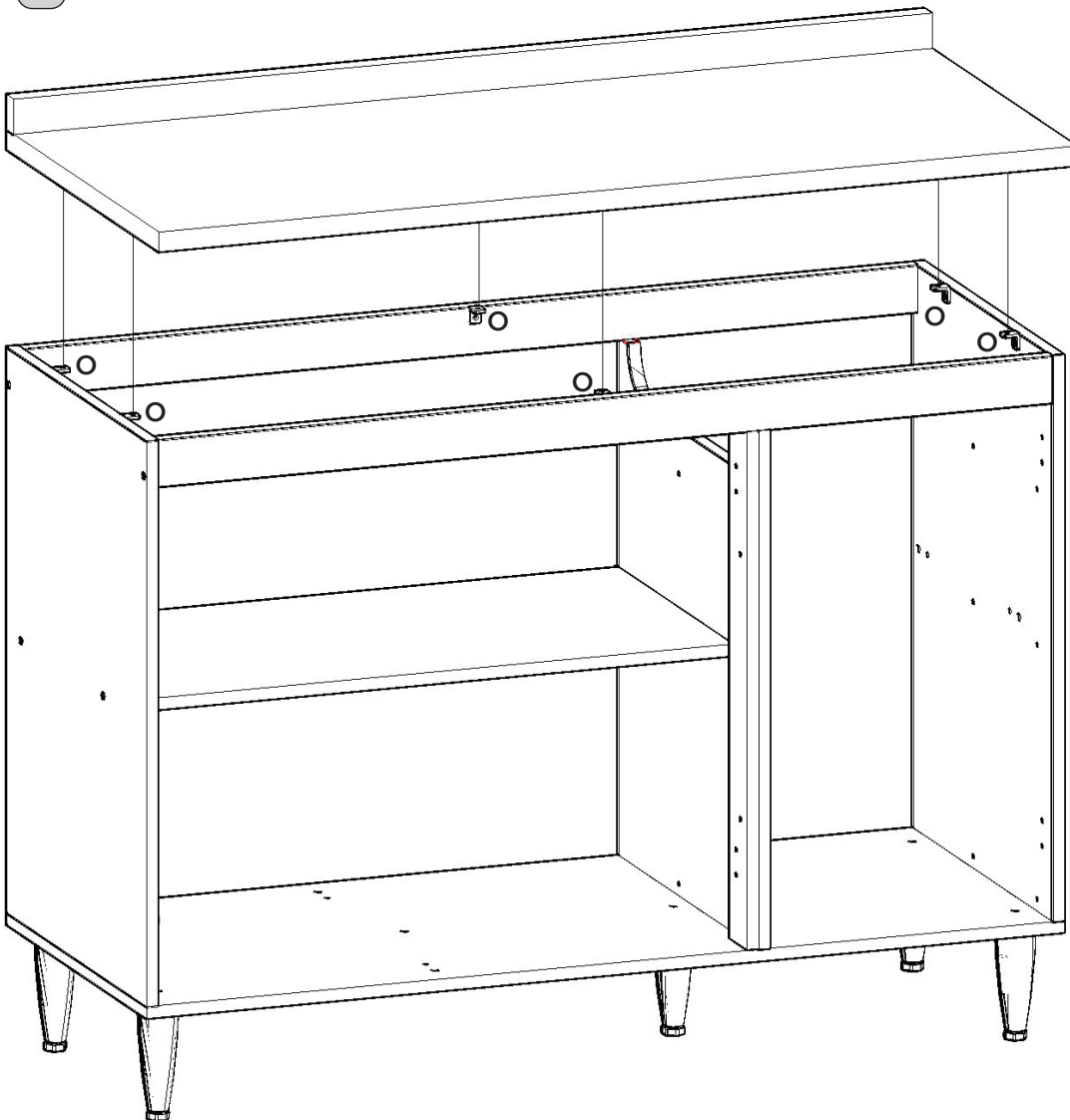

Caso o móvel seja montado com a opção do tampo, fixar o mesmo com 06 cantoneiras (O) e os parafusos 3,5x14mm (F).

Si se monta el auricular con la opción de la cubierta, fijarlo con Los ángulos 06 (O) y 3,5 x14mm tornillos (F).

If the furniture is to be installed with the top cover option, fix it with 06 (O) and 3.5x14mm screws (F).

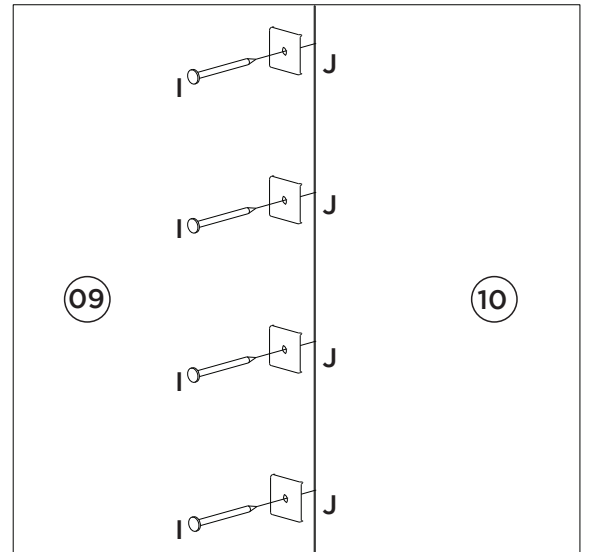
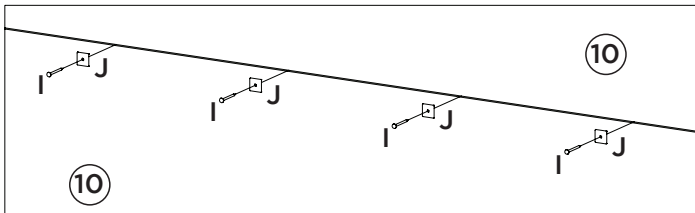
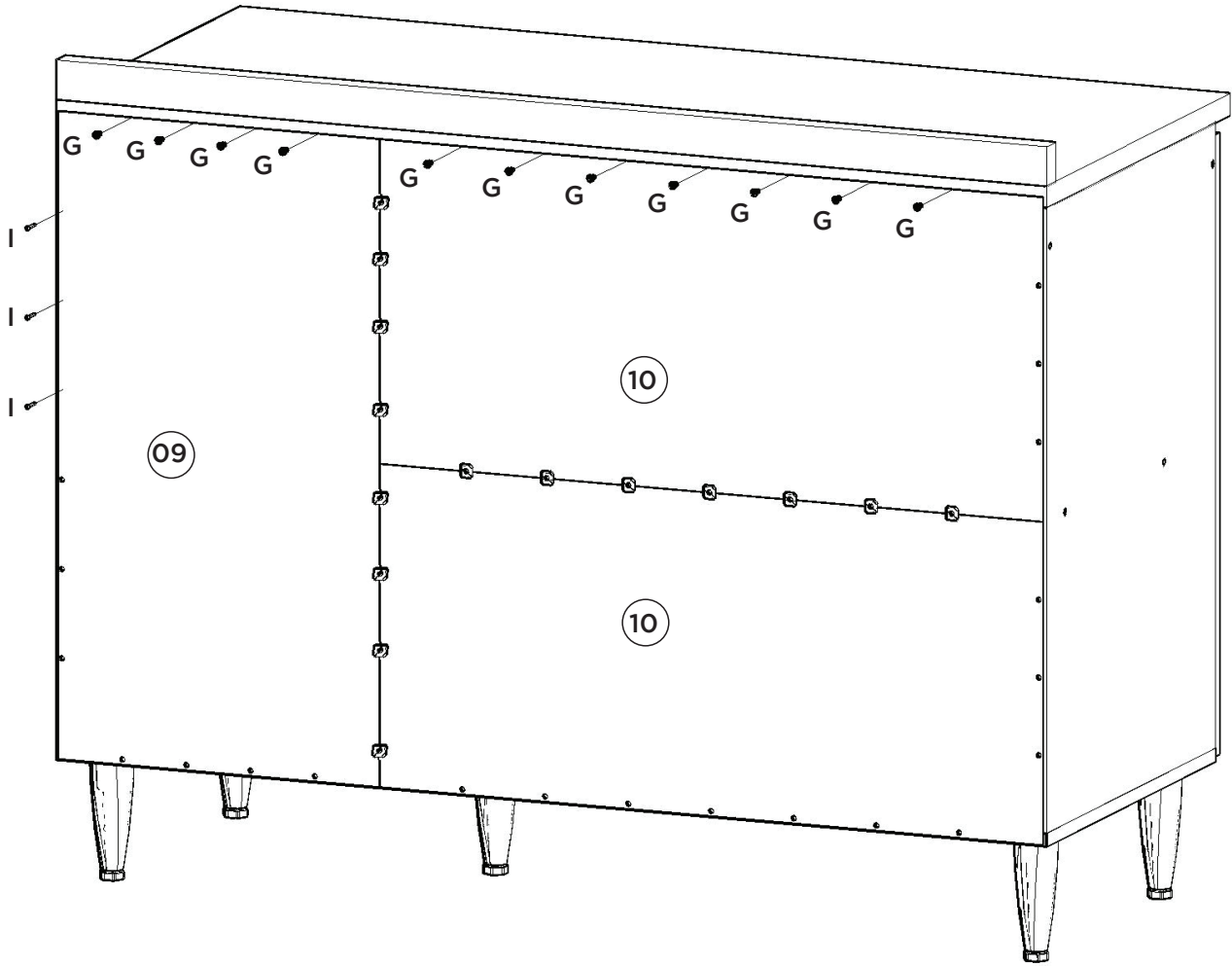

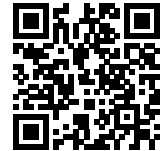
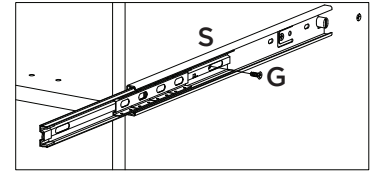
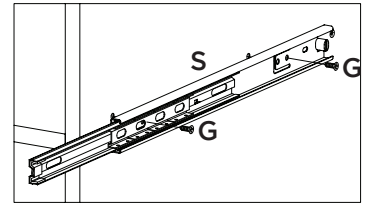
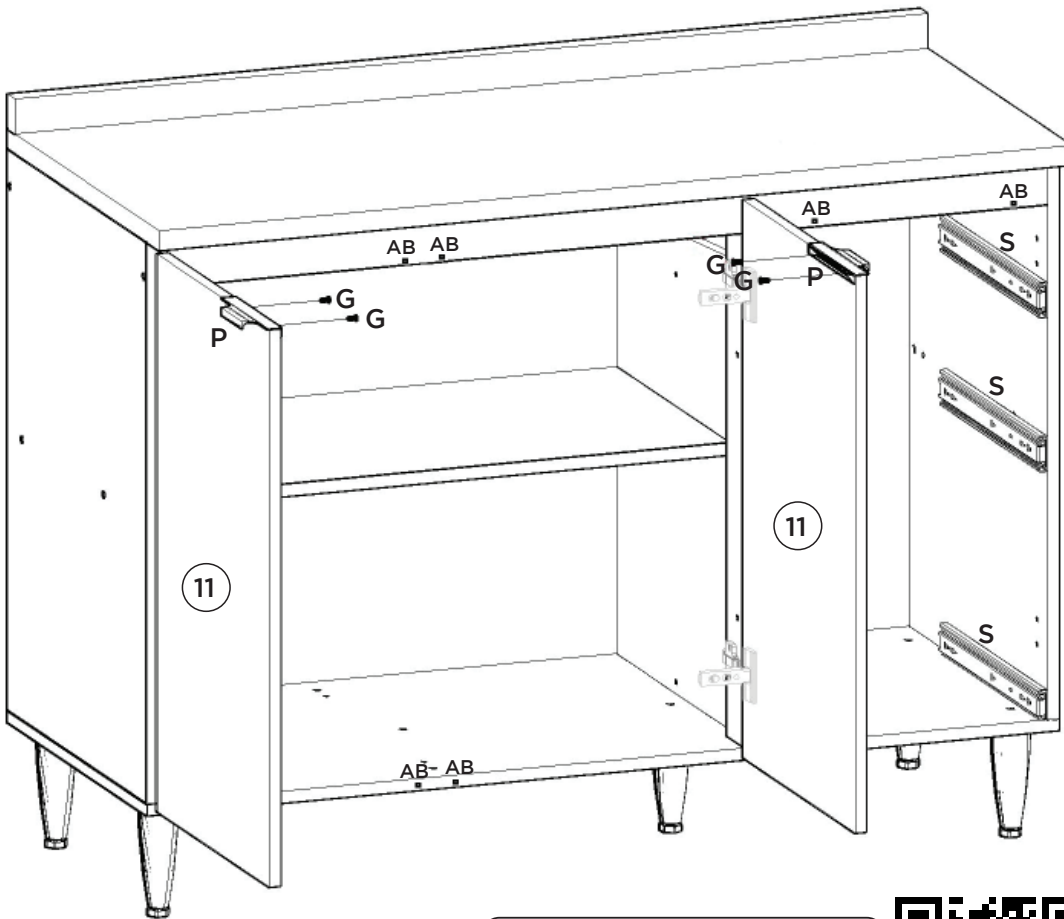

Vídeo: Dicas para fixar a Corrediça

Vídeo: Consejos para arreglar la diapositiva

Vídeo: Tips for Fixing the Slide

Vídeo: Instalar e regular Dobradiças

Vídeo: Instale y ajuste las bisagras

Vídeo: Install and adjust hinges

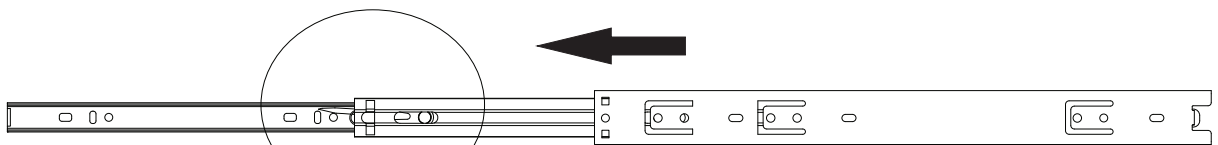
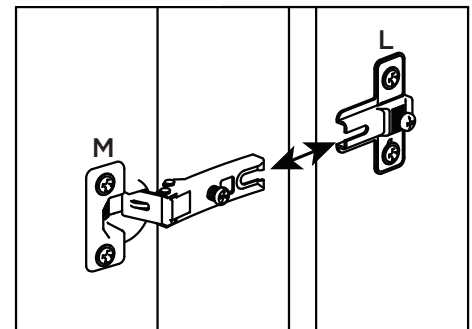
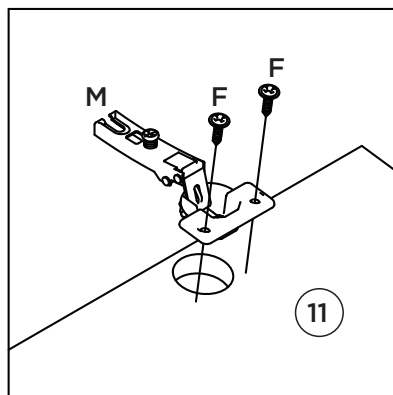
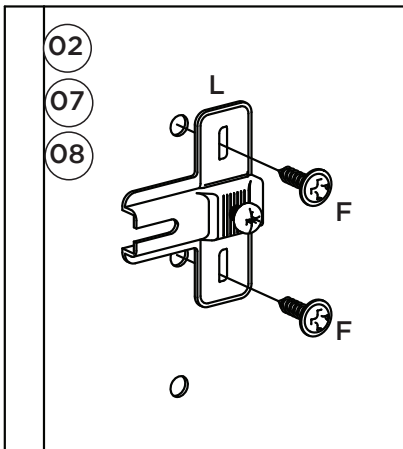
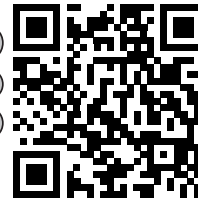

Para a desmontagem da corrediça siga a instrução ao lado.

Para el desmontaje seguimiento de diapositivas la instrucción siguiente a.

For the dismount of the sliding onem follows the instruction aside.

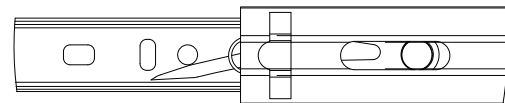
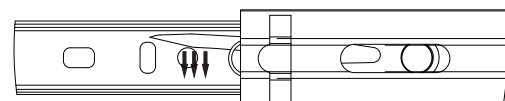

Fixar as corrediças nessas furações
 Fijar las diapositivas de estos agujeros
 Fix slides in these drillings

Parede
pared
Wall

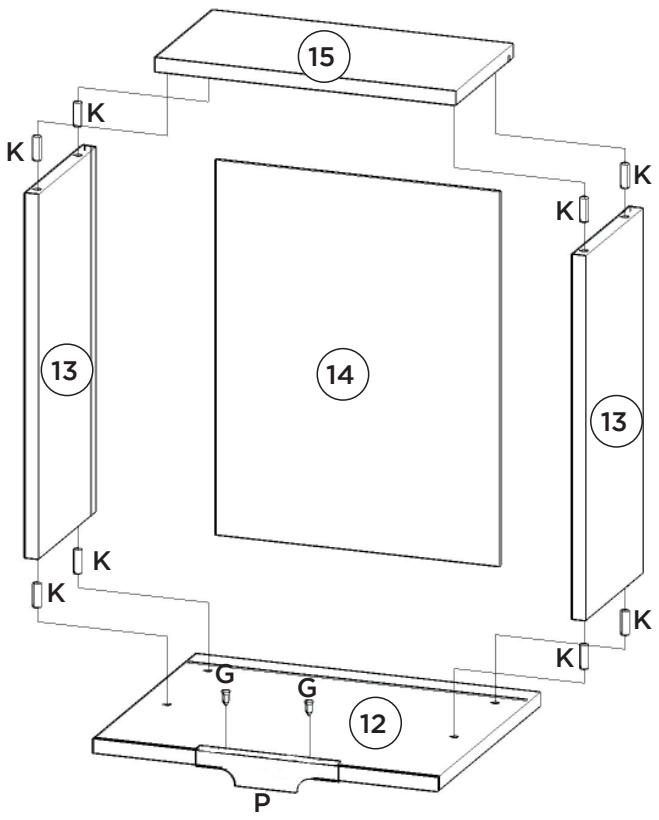
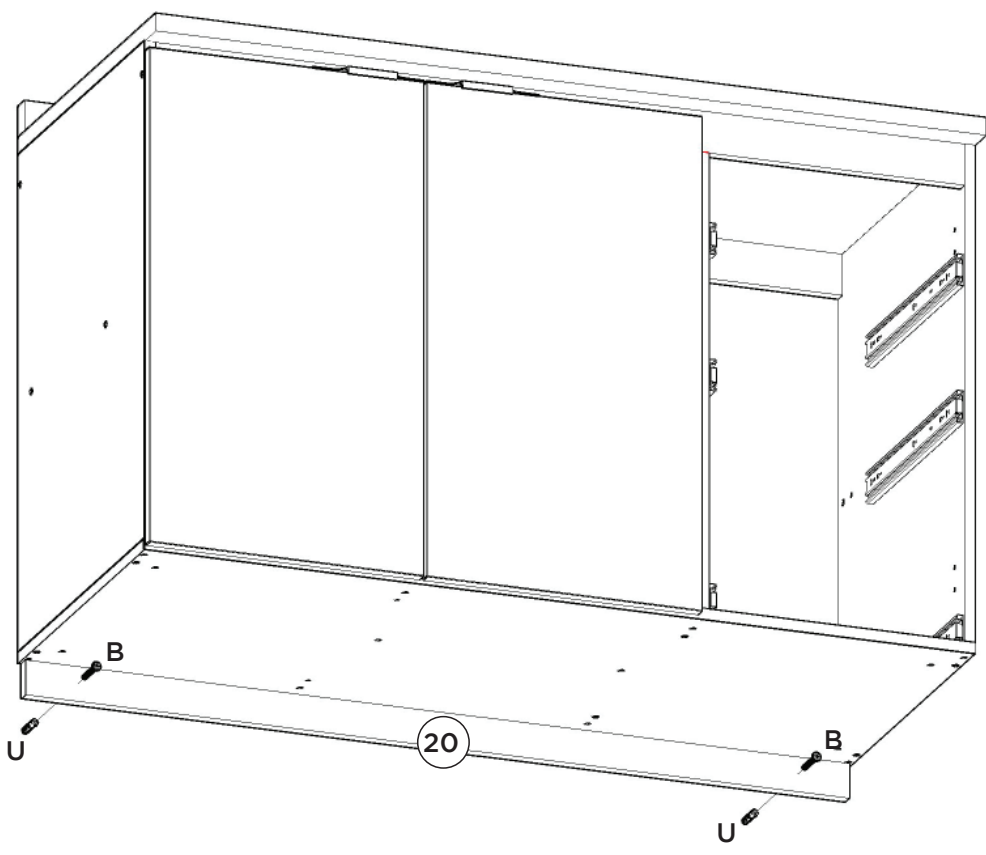

A corrediça (S) deverá ser alinhada com a parte de baixo do lado de gaveta (13).

La carcasa (S) será alineada con la parte de por el lado del cajón (13).

The slide (S) should be aligned with the underside of the drawer side (13).

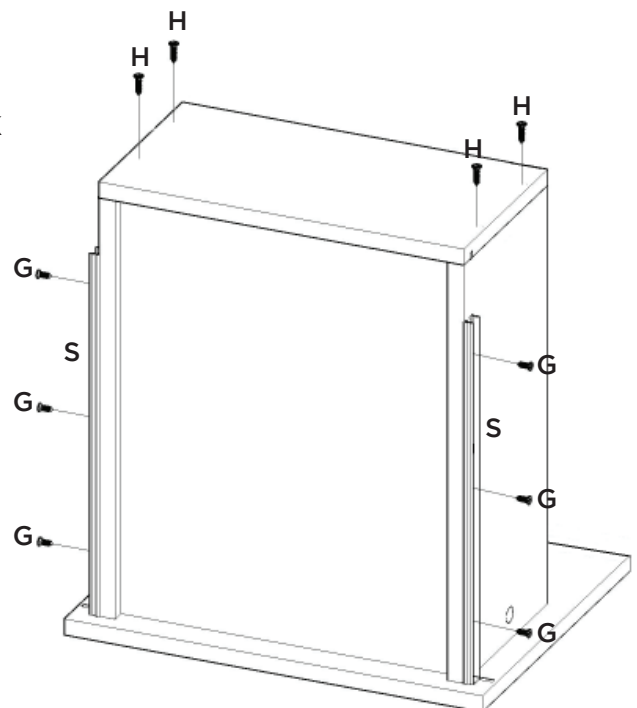
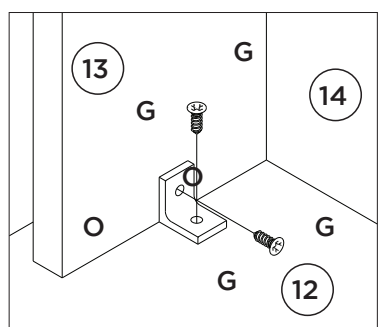

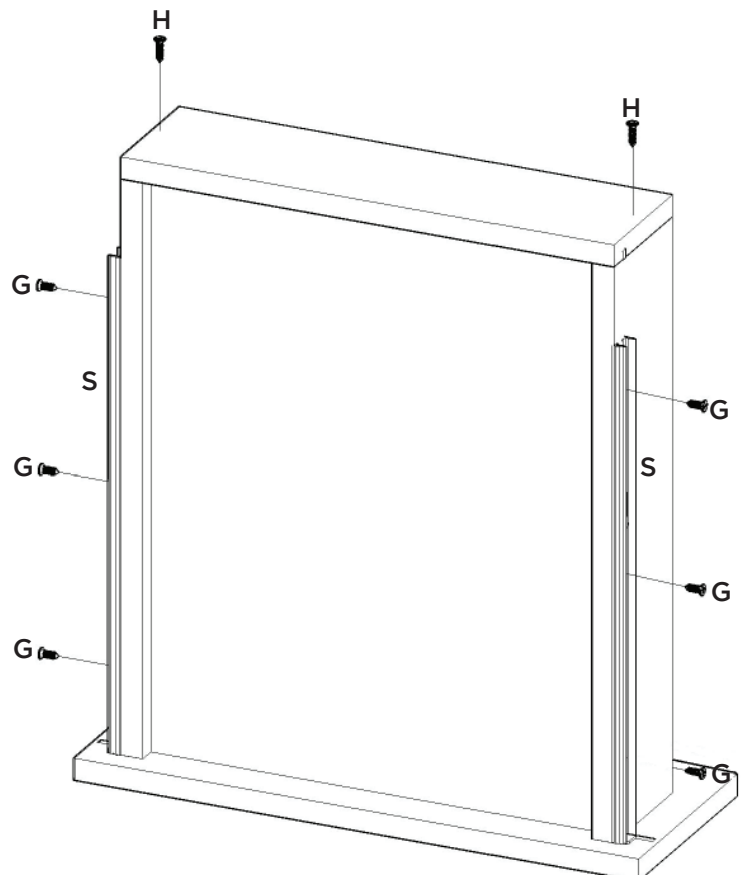
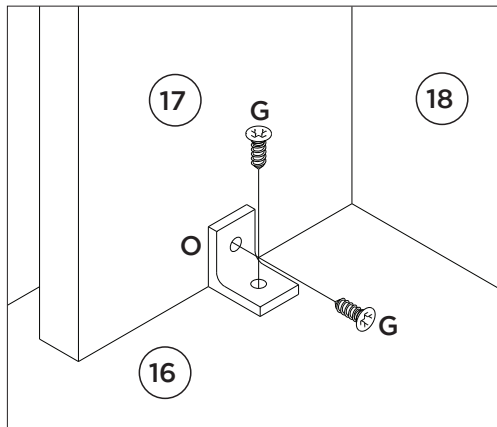
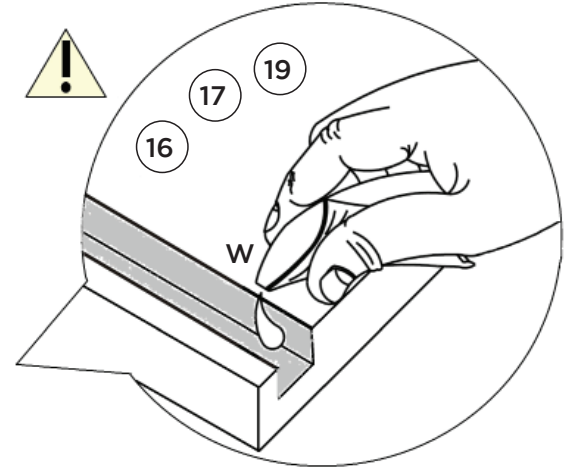
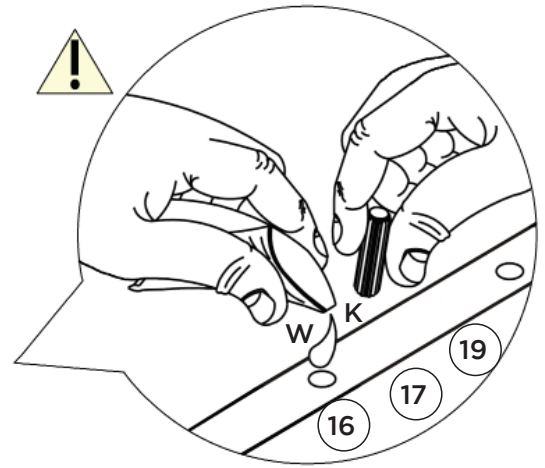
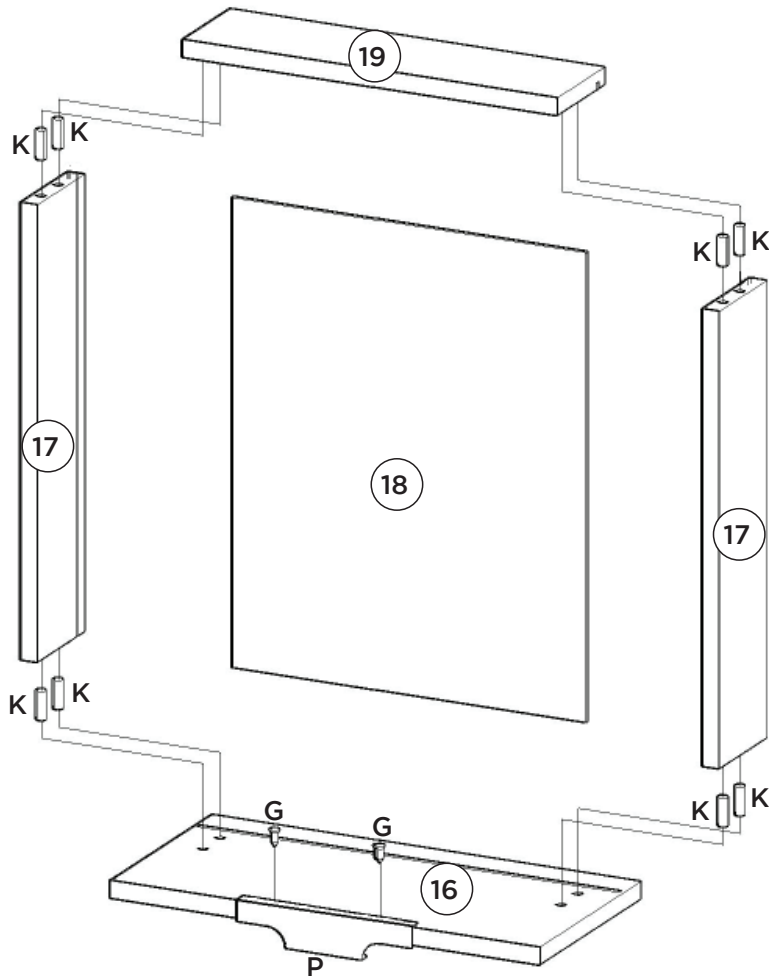











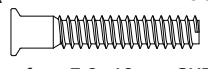
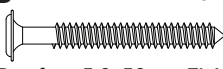

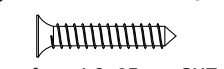
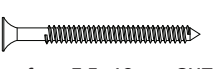

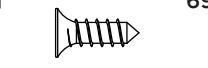

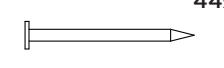
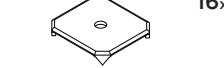





A correia (S) deverá ser alinhada com a parte de baixo do lado de gaveta (17).

La carcasa (S) será alineada con la parte de por el lado del cajón (17).

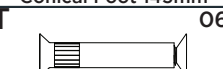
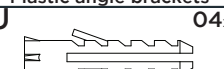
The slide (S) should be aligned with the underside of the drawer side (17).

Item	Caixa Caja Box	Qtd Ctd Qty	Descrição Descripción Description	Medidas (mm) Dimensions (mm) Size (measurements) (mm)
01	1/1	01	Base Base Base	1200x490x15
02	1/1	01	Lateral esquerda Lateral izquierda Left side	715x490x15
03	1/1	01	Divisão División Division	655x490x15
04	1/1	01	Prateleira Estante Shelf	784x400x15
05	1/1	01	Travessa frontal Travesaño frontal Front crossbar	1169x60x15
06	1/1	01	Travessa traseira Travesaño trasero Rear bumper	1169x60x15
07	1/1	01	Lateral direita Lateral derecha Right side	715x490x15
08	1/1	01	Pilastra da Porta Pilastra Puerta Pilaster door	654x60x15
09	1/1	01	Fundo menor Fondo menor Minor fund	727x389x3
10	1/1	02	Fundo maior Fondo mayor Greater Fund	803x363x3
11	1/1	02	Porta Puerta Door	710x396x15
12	1/1	01	Frente de Gaveta Maior Frente de cajón más grande Larger Drawer Front	396x318x15
13	1/1	02	Lado de gaveta Maior Lado del cajón más grande Larger drawer side	400x180x15
14=18	1/1	01	Fundo de gaveta Fondo de cajón Bottom of drawer	411x326x3
15	1/1	01	Ripa de Trás Maior Tablilla trasera más grande Larger rear clapboard	345x180x15
16	1/1	02	Frente de gaveta Frente de cajón Front of drawer	396x192x15
17	1/1	04	Lado de Gaveta Lado del cajón Drawer Side	400x90x15
18=14	1/1	02	Fundo de gaveta Fondo de cajón Bottom of drawer	411x326x3
19	1/1	02	Ripa de trás Malla detrás Rear lath	345x90x15
20	1/1	01	Travessa Sustentação Travessa Ayuda Support Travessa	1190x50x15

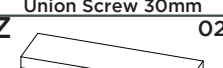
Ferragens | Herrajes | Hardware

A  Parafuso 7,0x40mm CHT. Tornillo 7,0x40mm CHT. Screw 7,0x40mm CHT.	B  Parafuso 5,0x50mm FLA. Tornillo 5,0x50mm FLA. Screw 5,0x50mm FLA.	C  Parafuso 4,5x50mm CHT. Tornillo 4,5x50mm CHT. Screw 4,5x50mm CHT.	D  Parafuso 4,0x25mm CHT. Tornillo 4,0x25mm CHT. Screw 4,0x25mm CHT.	E  Parafuso 3,5x40mm CHT. Tornillo 3,5x40mm CHT. Screw 3,5x40mm CHT.	F  Parafuso 3,5x14mm FLA. Tornillo 3,5x14mm FLA. Screw 3,5x14mm FLA.
G  Parafuso 3,5x12mm CHT. Tornillo 3,5x12mm CHT. Screw 3,5x12mm CHT.	H  Parafuso 3,0x30mm CHT. Tornillo 3,0x30mm CHT. Screw 3,0x30mm CHT.	I  Prego 10x10mm Clavo 10x10mm Nail 10x10mm	J  Fixador de fundos Fijador de fondos Bottom fixer	K  Cavilha 8x25mm Cinta 8x25mm Dowel 8x25mm	L  Calço metal alto 3mm Calzado metálico alto 3mm 3mm high metal chock
M  Dobradiça metal 35mm baixo Bisagras metálicas 35mm bajo Metal hinge 35mm low	N  Pé Cônico 145mm Pie Cónico 145mm Conical Foot 145mm	O  Cantoneira plástica Cantonera plástica Plastic angle brackets	P  Puxador PV392 160mm Tirador PV392 160mm PV392 Handle 160mm	Q  Adesivo tapa parafuso 17mm Adhesivo tapón de tornillo 17mm Bolt cover adhesive 17mm	R  Adesivo tapa parafuso 10mm Adhesivo tapón de tornillo 10mm Bolt cover adhesive 10mm
S  Corrediza telescópica Diapositivas telescópicas Telescopic slides	T  Parafuso União 30mm Tornillo Unión 30mm Union Screw 30mm	U  Bucha plástica 8mm Bucha de plástico 8mm 8mm plastic bushing	V  Divisor talheres 398x313mm Divisor cubiertos 398x313mm Cutlery divider 398x313mm	W  Sachê de cola Bolsa de pegamento Glue bag	X  Giz de correção Tiza de corrección Chalk of correction
Y  Suporte de fixação Soporte de fijación Mounting bracket	Z  Proteção para cantoneira Ángulo de protección Protection angle	AA  Etiqueta resinada Henn Etiqueta resinada Henn Henn resin label	AB  Batente PVC para Porta Parada de PVC para Puerta PVC Door Stop		



O parafuso (T) deve ser usada somente quando este módulo for acoplado a outro módulo componível Henn.

RECOMENDAÇÃO

Para fixar o móvel na parede usar o suporte de fixação (Y), o parafuso 3,5x14mm FLA (F), a Bucha 8mm (U) e o parafuso 5,0x50mm FLA (B).



El tornillo (T) se debe utilizar sólo cuando el módulo está conectado a otro módulo componible Henn.

RECOMENDACIÓN

Para conectar el móvil a la pared con el soporte (Y), tornillo 3,5 x14mm FLA (F), el casquillo de 8 mm (U) y el 5,0 x50mm tornillo FLA (B).



The screw (T) should be used only when this module is attached to another Henn modular module.

RECOMMENDATION

To fix the furniture to the wall use the mounting bracket (Y), the 3.5x14mm FLA (F) screw, the 8mm bushing (U) and the 5.0x50mm FLA (B).

HENNInd. e Com. de Móveis Henn
Mondaí - SC - Brasil

☎ +55 49 3674.3500

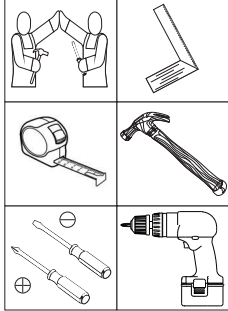
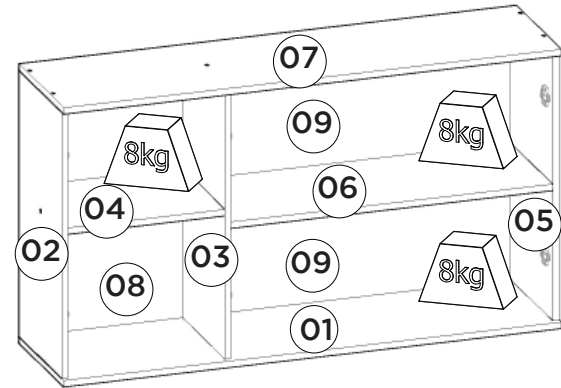
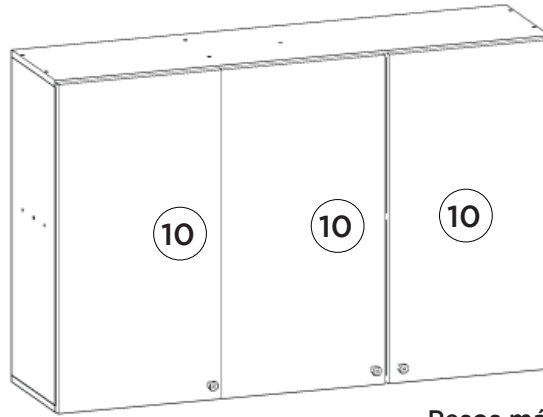
📷 @moveishenn
www.henn.com.br**INSTRUÇÕES DE MONTAGEM****INSTRUCCIONES DE MONTAJE
ASSEMBLY INSTRUCTIONS****Aéreo 03 Portas 1200mm Essência | Aéreo 03 Puertas 1200mm Essência |
Aerial 03 Doors 1200mm Essência**Referência/Cor
c C550-133 Areia HPRequisitos para montagem
Requisitos para la montaje
Assembly RequirementsImagens meramente ilustrativas
Imágenes meramente ilustrativas
Images for illustration only**Pesos máximos recomendados com carga distribuída
Peso máximo recomendado con la carga distribuida
Recommended maximum weight with distributed load.****Lista de Peças | Lista de piezas | List of parts**

Item	Caixa Caja Box	Qtd Ctd Qty	Descrição Descripción Description	Medidas (mm) Dimensions (mm) Size (measurements) (mm)
01	1/1	01	Base Base Base	1200x295x15
02	1/1	01	Lateral Esquerda Lateral Izquierda Right Left	750x295x15
03	1/1	01	Divisão División Division	750x295x15
04	1/1	01	Prateleira Menor Estante Pequeno Smaller Shelf	381x295x15
05	1/1	01	Lateral Direita Lateral Derecha Right Side	750x295x15
06	1/1	01	Prateleira Estante Shelf	773x295x15
07	1/1	01	Tampo Tapa Top	1200x295x15
08	1/1	01	Fundo Lateral Fondo Lateral Lateral Background	774x400x3
09	1/1	02	Fundo Fondo Bottom	792x386x3
10	1/1	03	Porta Puerta Door	775x396x15

Ferragens | Herrajes | Hardware

A 03x Parafuso 5,0x50mm FLA. Tornillo 5,0x50mm FLA. Screw 5,0x50mm FLA.	B 16x Parafuso 3,5x40mm CHT. Tornillo 3,5x40mm CHT. Screw 3,5x40mm CHT.	C 30x Parafuso 3,5x14mm FLA. Tornillo 3,5x14mm FLA. Screw 3,5x14mm FLA.	D 60x Prego 10x10mm Clavo 10x10mm Nail 10x10mm	E 20x Cavilha 8x25mm Cinta 8x25mm Dowel 8x25mm	F 06x Calço metal alto 3mm Calzado metálico alto 3mm 3mm high metal chock
G 06x Dobradilha metal 35mm Colo Baixo Bisagra de metal 35mm Colo Bajo Metal hinge 35mm Colo Low	H 03x Parafuso 3,5x25mm FLA. Tornillo 3,5x25mm FLA. Screw 3,5x25mm FLA.	I 03x Bucha plástica 8mm Bucha de plástico 8mm 8mm plastic bushing	J 03x Suporte de fixação Soporte de fijación Mounting bracket	K 03x Proteção para cantoneira Ángulo de protección Protection angle	L 04x Parafuso União 30mm Tornillo Unión 30mm Union Screw 30mm
M 06x Batente PVC para Porta Parada de PVC para Puerta PVC Door Stop	N 01x Sachê de cola Bolsa de pegamento Glue bag	O 14x Adesivo tampa parafuso 10mm Adhesivo tapón de tornillo 10mm Bolt cover adhesive 10mm	P 16x Fixador de fundos Fijador de fondos Bottom fixer	Q 02x Giz de correção Tiza de corrección Chalk of correction	R 01x Etiqueta resinada Henn Etiqueta resinada Henn Henn resin label
S 03x Puxador Pontual Diamante Tirador de punta de diamante Diamond Point Handle					

O parafuso (L) deve ser usada somente quando este módulo for acoplado a outro módulo componível Henn.

El tornillo (L) se debe utilizar sólo cuando el módulo está conectado a otro módulo componible Henn.

The screw (L) should be used only when this module is attached to another Henn modular module.

RECOMENDAÇÃO

Para fixar o móvel na parede usar o suporte de fixação (J), o parafuso 3,5x14mm FLA (C), a Bucha 8mm (I) e o parafuso 5,0x50mm FLA (A).

RECOMENDACIÓN

Para conectar el móvil a la pared con el soporte (J), tornillo 3,5 x14mm FLA (C), el casquillo de 8 mm (I) y el 5,0 x50mm tornillo FLA (A).

RECOMMENDATION

To fix the furniture to the wall use the fixing bracket (J), the 3.5x14mm FLA (C) screw, the 8mm bushing (I) and the 5.0x50mm FLA (A).

1º

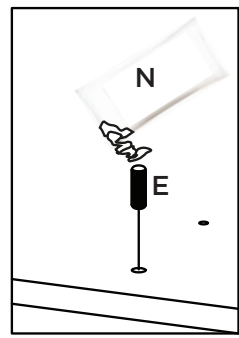
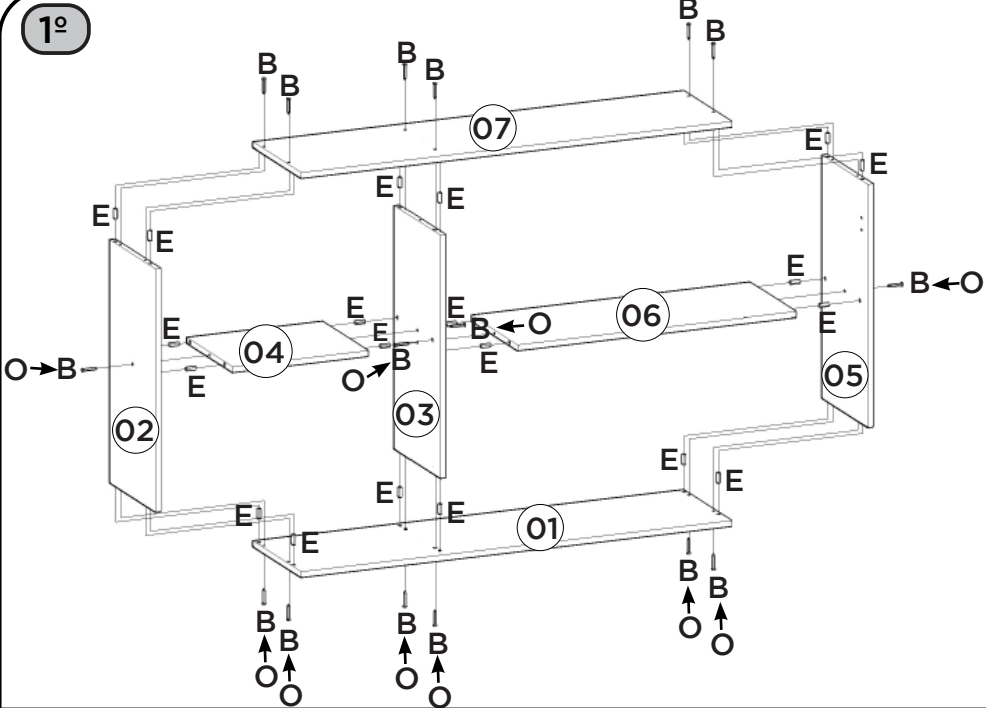

- Utilizar o sachê de cola (N) em todas as cavilhas (E) do produto.
- Con el pegamento sobre (N) en todos los pernos (E) producto.
- Use the glue sachet (N) on all the pegs (E) of the product.

2º

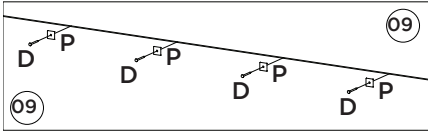
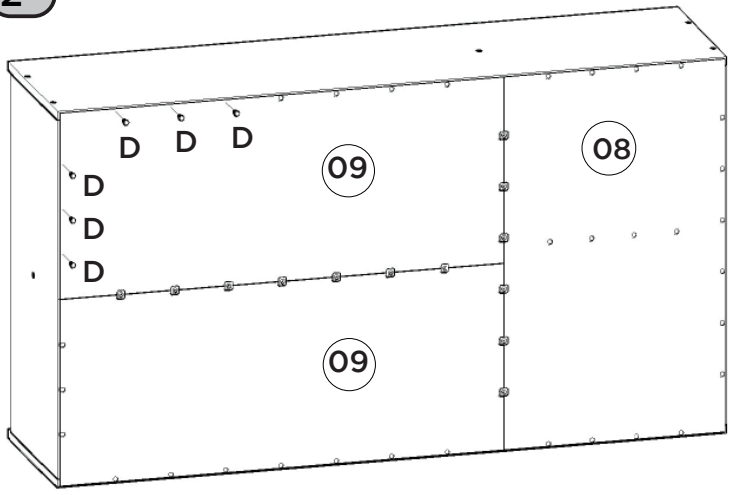

- AVISO**
Para limpeza de seu móvel, use uma flanela seca ou umedecida, e não utilize produtos químicos que possam danificar seu produto.
- SISTEMA DE MONTAGEM**
O sistema de montagem dos produtos, funciona de acordo com a ordem crescente dos números indicados no desenho. Ex: 01, 02, 03, 04... até a conclusão da montagem.

- ADVERTENCIA**
Para limpieza de su móvil, use una flanela seca o húmeda, y no utilice productos químicos que puedan dañar su producto.

3º

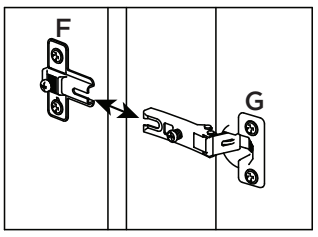
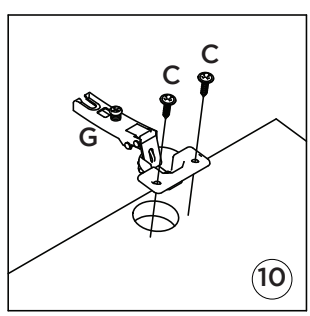
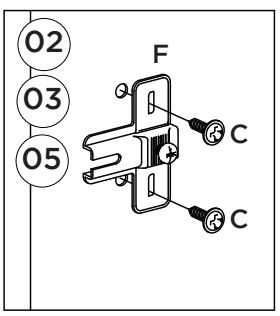

10



- Vídeo: Instalar e regular Dobradiças
- Vídeo: Instale y ajuste las bisagras
- Vídeo: Install and adjust hinges

- SISTEMA DE MONTAJE**
El sistema de montaje de los productos funciona de acuerdo con el orden creciente de los números indicados en el dibujo. Ej.: 01, 02, 03, 04... hasta la conclusión del montaje.

- NOTICE**
To clean your furniture, use a dry or wet cloth, and do not use chemicals that may damage your product.

- ASSEMBLY SYSTEM**
The products' assembly system works according to the increasing order of the indicated numbers. For example: 01, 02, 03, 04 ... to the end of the assembly.

