

**HENN**Ind. e Com. de Móveis Henn  
Mondai - SC - Brasil

☎ +55 49 3674.3500



 @moveishenn  
www.henn.com.br
**INSTRUÇÕES DE MONTAGEM****INSTRUCCIONES DE MONTAJE  
ASSEMBLY INSTRUCTIONS****Aéreo 03 Portas 1200mm Belize | Aéreo 03 Puertas 1200mm Belize | Aerial 03 Doors 1200mm Belize**

Referência/Cor

c C500-131 Cinza

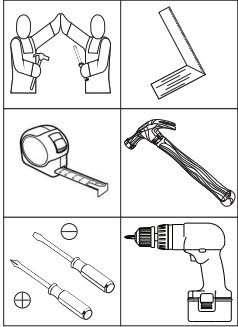
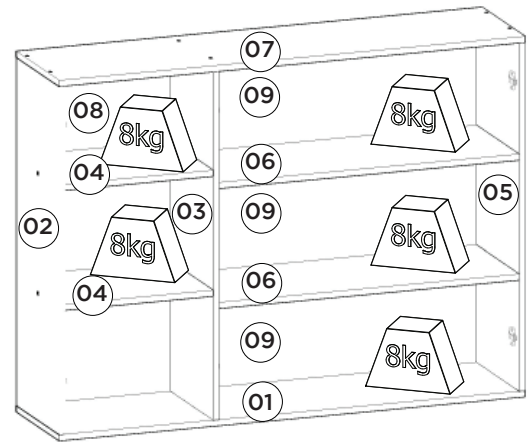
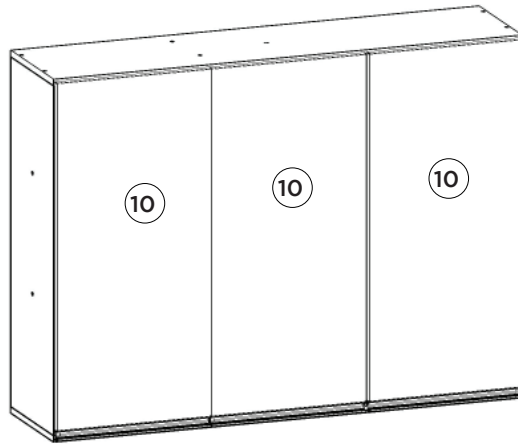







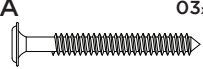

Requisitos para montagem  
Requisitos para la montaje  
Assembly RequirementsImagens meramente ilustrativas  
Imágenes meramente ilustrativas  
Images for illustration only

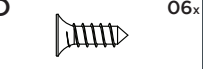
**Pesos máximos recomendados com carga distribuída**  
**Peso máximo recomendado con la carga distribuida**  
**Recommended maximum weight with distributed load.**

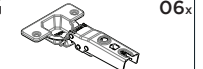
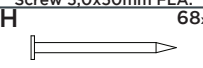
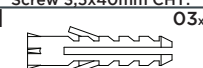
**Lista de Peças | Lista de piezas | List of parts**

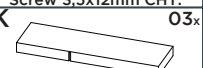
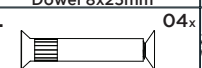
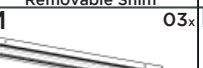
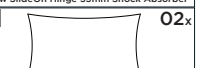
Item	Caixa Caja Box	Qtd Ctd Qty	Descrição   Descripción   Description	Medidas (mm)   Dimensions (mm)   Size (measurements) (mm)
01	1/1	01	Base   Base   Base	1200x295x15
02	1/1	01	Lateral Esquerda   Lateral Izquierda   Right Left	870x295x15
03	1/1	01	Divisão   División   Division	870x295x15
04	1/1	02	Prateleira Menor   Estante Pequeno   Smaller Shelf	382x295x15
05	1/1	01	Lateral Direita   Lateral Derecha   Right Side	870x295x15
06	1/1	02	Prateleira   Estante   Shelf	772x295x15
07	1/1	01	Tampo   Tapa   Top	1200x295x15
08	1/1	01	Fundo Lateral   Fondo Lateral   Lateral Background	894x401x3
09	1/1	03	Fundo   Fondo   Bottom	790x298x3
10	1/1	03	Porta   Puerta   Door	865x396x15

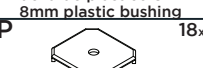
**Ferragens | Herrajes | Hardware**

<b>A</b>  Parafuso 5,0x50mm FLA. Tornillo 5,0x50mm FLA. Screw 5,0x50mm FLA.	<b>03x</b>	<b>B</b>  Parafuso 3,5x40mm CHT. Tornillo 3,5x40mm CHT. Screw 3,5x40mm CHT.	<b>20x</b>	<b>C</b>  Parafuso 3,5x14mm FLA. Tornillo 3,5x14mm FLA. Screw 3,5x14mm FLA.	<b>42x</b>	<b>D</b>  Parafuso 3,5x12mm CHT. Tornillo 3,5x12mm CHT. Screw 3,5x12mm CHT.	<b>06x</b>	<b>E</b>  Cavilha 8x25mm Cinta 8x25mm Dowel 8x25mm	<b>28x</b>	<b>F</b>  Calço Removível Calzado extraíble Removable Shim	<b>06x</b>	<b>G</b>  Dobradilha SlideOn Baja Amortecedor 35mm Bisagra SlideOn Baja Amortiguador 35mm Low SlideOn Hinge 35mm Shock Absorber	<b>06x</b>
<b>H</b>  Prego 10x10mm Clavo 10x10mm Nail 10x10mm	<b>68x</b>	<b>I</b>  Buchas de plástico 8mm 8mm plastic bushing	<b>03x</b>	<b>J</b>  Suporte de fixação Soporte de fijación Mounting bracket	<b>03x</b>	<b>K</b>  Proteção para cantoneira Ángulo de protección Protection angle	<b>03x</b>	<b>L</b>  Parafuso União 30mm Tornillo Unión 30mm Union Screw 30mm	<b>04x</b>	<b>M</b>  Puxador ALX179 - 396mm Tirador ALX179 - 396mm ALX179 - 396mm Handle	<b>03x</b>	<b>N</b>  Sachê de cola Bolsa de pegamento Glue bag	<b>02x</b>
<b>O</b>  Adesivo tapan de tornillo 10mm Bolt cover adhesive 10mm	<b>18x</b>	<b>P</b>  Fixador de fundos Fijador de fondos Bottom fixer	<b>18x</b>	<b>Q</b>  Giz de correção Tiza de corrección Chalk of correction	<b>02x</b>	<b>R</b>  Etiqueta resinada Henn Etiqueta resinada Henn Henn resin label	<b>01x</b>						



O parafuso (L) deve ser usada somente quando este módulo for acoplado a outro módulo componível Henn.



El tornillo (L) se debe utilizar sólo cuando el módulo está conectado a otro módulo componible Henn.



The screw (L) should be used only when this module is attached to another Henn modular module.

**RECOMENDAÇÃO**

Para fixar o móvel na parede usar o suporte de fixação (J), o parafuso 3,5x14mm FLA (C), a Bucha 8mm (I) e o parafuso 5,0x50mm FLA (A).

**RECOMENDACIÓN**

Para conectar el móvil a la pared con el soporte (J), tornillo 3,5 x14mm FLA (C), el casquillo de 8 mm (I) y el 5,0 x50mm tornillo FLA (A).

**RECOMMENDATION**

To fix the furniture to the wall use the fixing bracket (J), the 3.5x14mm FLA (C) screw, the 8mm bushing (I) and the 5.0x50mm FLA (A).

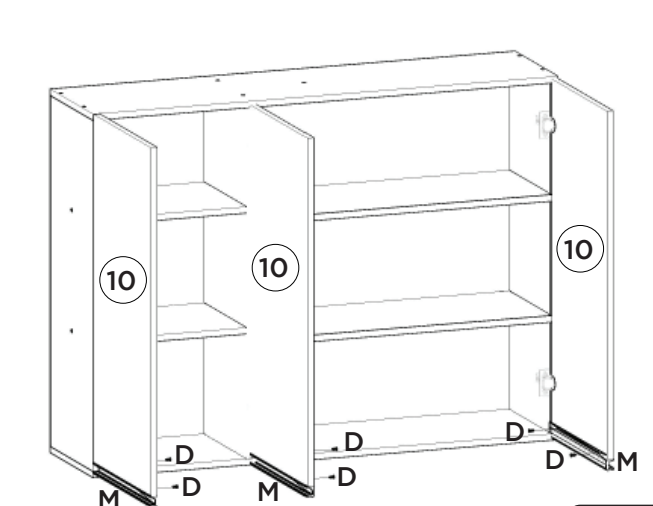
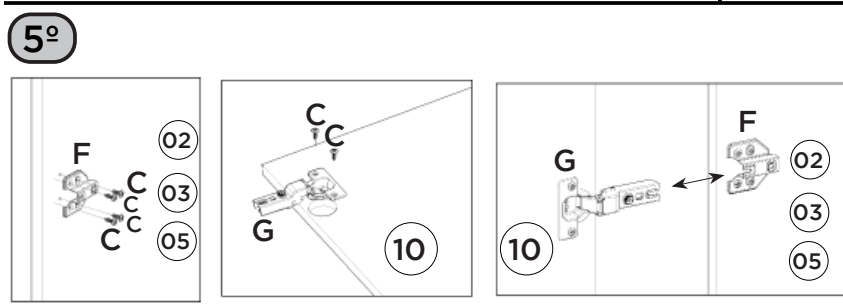
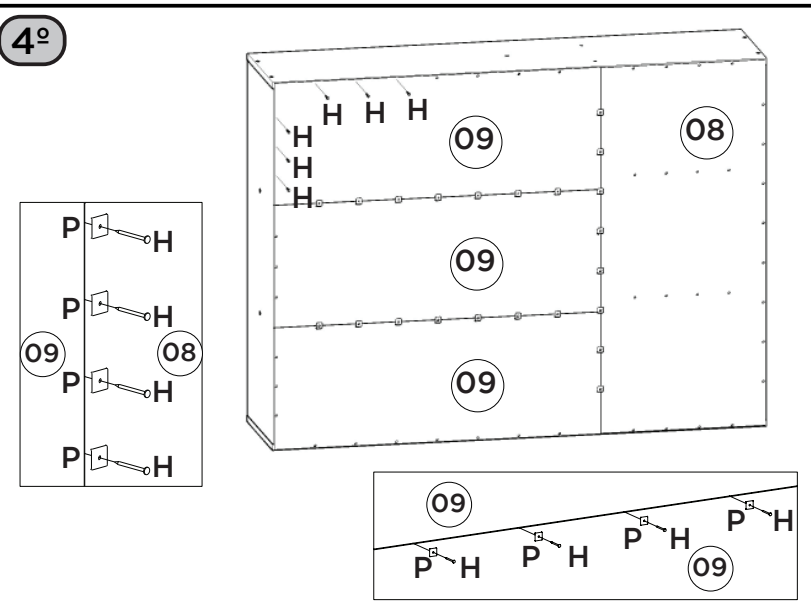
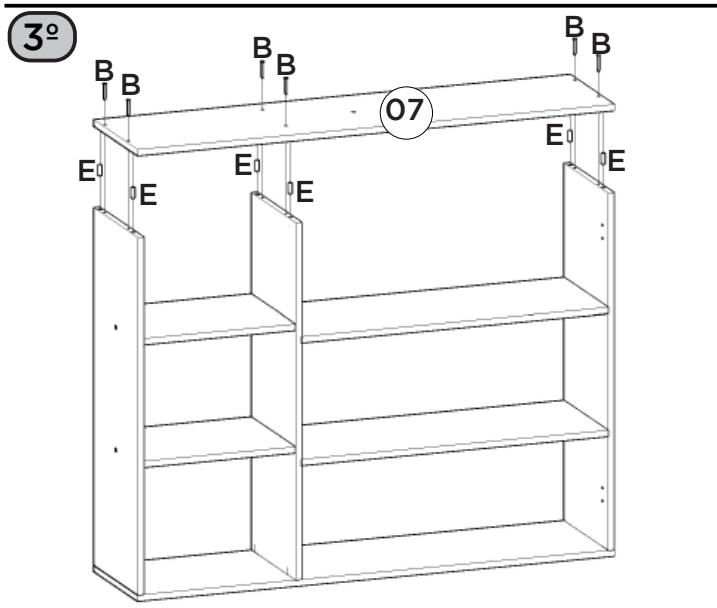
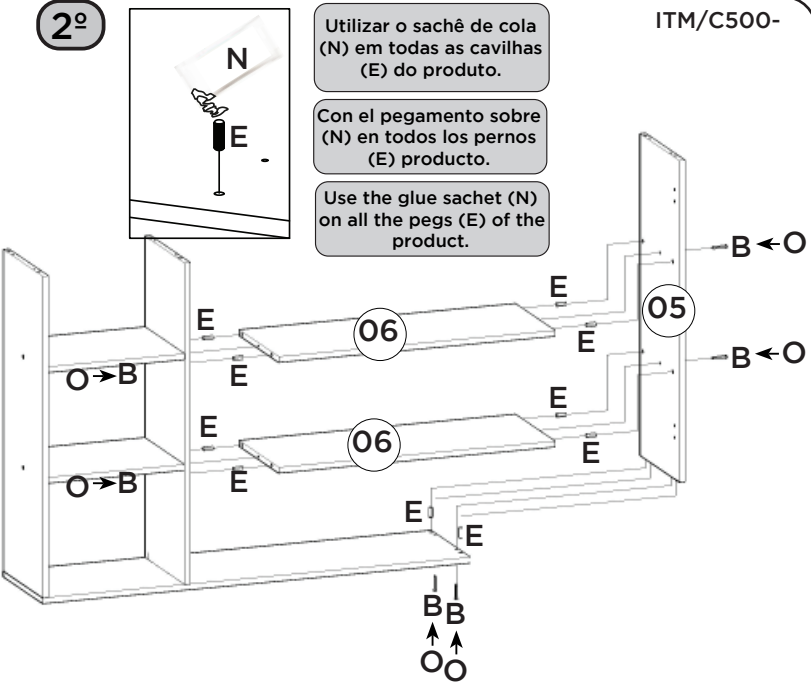
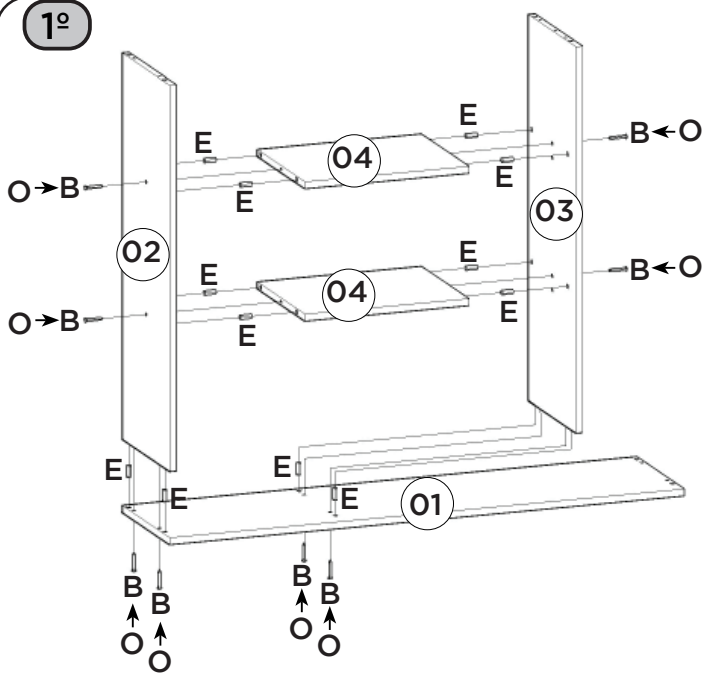

Video: Instalar e regular Dobradiças  
 Video: Instale y ajuste las bisagras  
 Video: Install and adjust hinges

**AVISO**  
 Para limpeza de seu móvel, use uma flanela seca ou umedecida, e não utilize produtos químicos que possam danificar seu produto.

**SISTEMA DE MONTAGEM**  
 O sistema de montagem dos produtos, funciona de acordo com a ordem crescente dos números indicados no desenho. Ex: 01, 02, 03, 04... até a conclusão da montagem.

**ADVERTENCIA**  
 Para limpeza de su móvel, use una flanela seca o húmeda, y no utilice productos químicos que puedan dañar su producto.

**SISTEMA DE MONTAJE**  
 El sistema de montaje de los productos funciona de acuerdo con el orden creciente de los números indicados en el dibujo. Ej.: 01, 02, 03, 04... hasta la conclusión del montaje.

**NOTICE**  
 To clean your furniture, use a dry or wet cloth, and do not use chemicals that may damage your product.

**ASSEMBLY SYSTEM**  
 The products' assembly system works according to the increasing order of the indicated numbers. For example: 01, 02, 03, 04 ... to the end of the assembly.

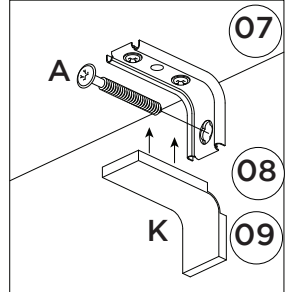
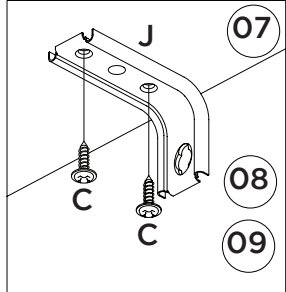

# HENN

Ind. e Com. de Móveis Henn  
Mondai - SC - Brasil

+55 49 3674.3500

@moveishenn  
www.henn.com.br

## INSTRUÇÕES DE MONTAGEM

INSTRUCCIONES DE MONTAJE  
ASSEMBLY INSTRUCTIONS

Aéreo 01 Porta Basculante 800mm Belize |  
Aéreo 01 Puerta Basculante 800mm Belize |  
01 air port Tipper 800mm Belize

c C502-131 - Cinza

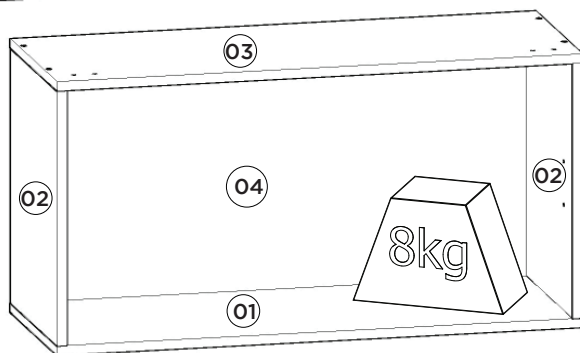
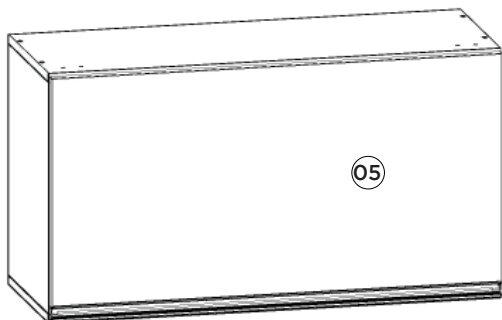

Pesos máximos recomendados com carga distribuída  
Peso máximo recomendado con la carga distribuída  
Recommended maximum weight with distributed load.

Requisitos para montagem  
Requisitos para la montaje  
Assembly Requirements

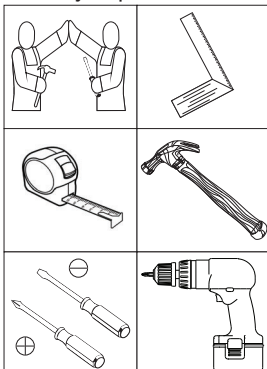

Imagens meramente ilustrativas  
Imágenes meramente ilustrativas  
Images for illustration only

### AVISO

Para limpeza de seu móvel, use uma flanela seca ou umedecida, e não utilize produtos químicos que possam danificar seu produto.

### SISTEMA DE MONTAGEM

O sistema de montagem dos produtos, funciona de acordo com a ordem crescente dos números indicados no desenho. Ex: 01, 02, 03, 04... até a conclusão da montagem.

### ADVERTENCIA

Para limpieza de su móvil, use una flanela seca o húmeda, y no utilice productos químicos que puedan dañar su producto.

### SISTEMA DE MONTAJE

El sistema de montaje de los productos funciona de acuerdo con el orden creciente de los números indicados en el dibujo. Ej.: 01, 02, 03, 04... hasta la conclusión del montaje.

### NOTICE

To clean your furniture, use a dry or wet cloth, and do not use chemicals that may damage your product.

### ASSEMBLY SYSTEM

The products' assembly system works according to the increasing order of the indicated numbers. For example: 01, 02, 03, 04 ... to the end of the assembly.

1º

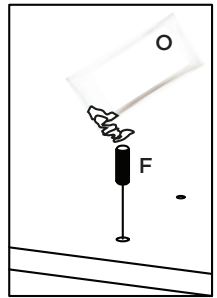
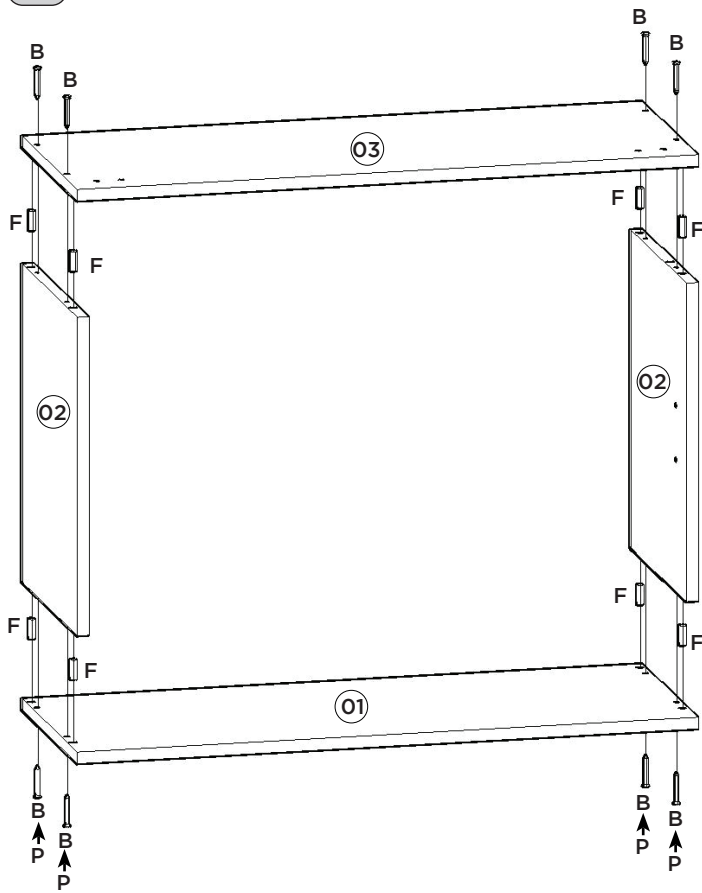

Utilizar o sachê de cola (O) em todas as cavilhas (F) do produto.

Con el pegamento sobre (O) en todos los pernos (F) producto.

Use the glue sachet (O) on all the pegs (F) of the product.

2º

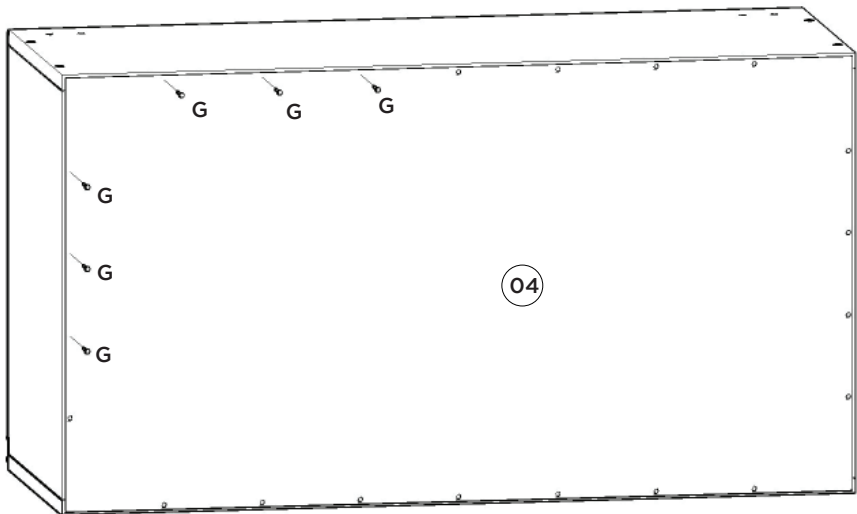

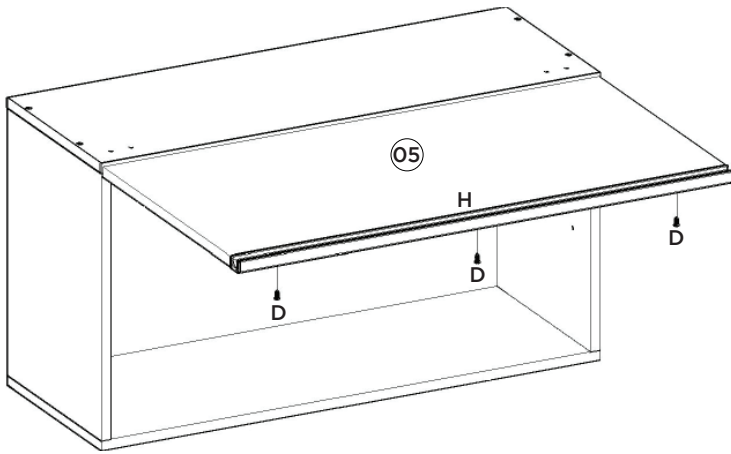

Video: Instalar e regular Dobradiças

Video: Instale y ajuste las bisagras

Video: Install and adjust hinges

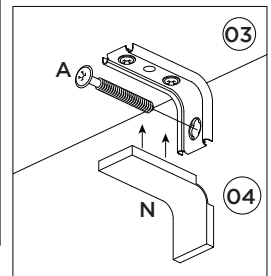
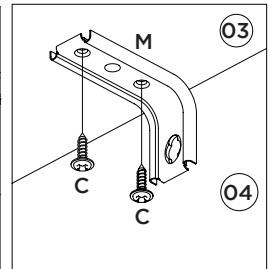
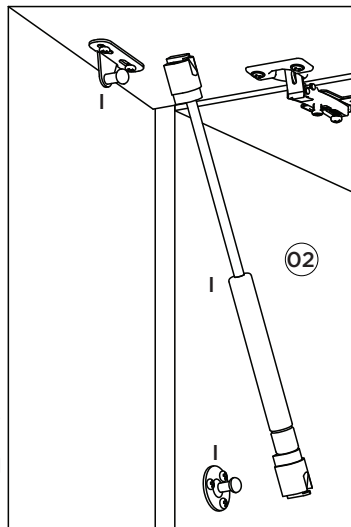
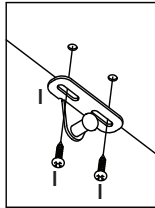
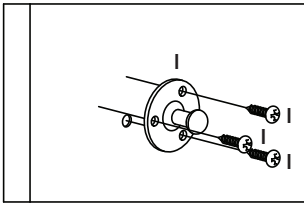
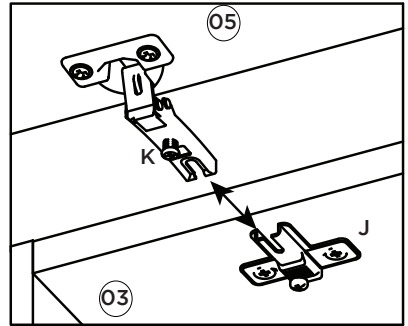
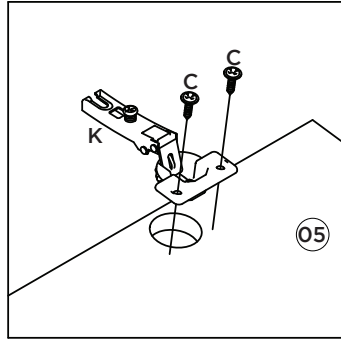
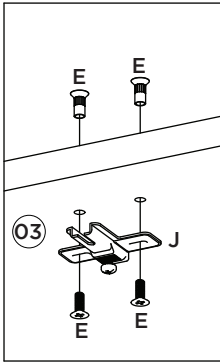











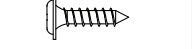

Video: Dicas para instalar o Kit Pistão à Gás

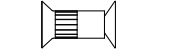
Video: Consejos para instalar el kit de pistón de gas

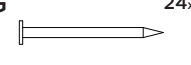
Video: Tips for installing the Gas Piston Kit

Item	Caixa Caja Box	Qtd Ctd Qty	Descrição   Descripción   Description	Medidas (mm)   Dimensions (mm)   Size (measurements) (mm)
01	1/1	01	Base   Base   Base	800x295x15
02	1/1	02	Lateral Direita Esquerda   Lateral Derecha Izquierda   Right Side Left	410x295x15
03	1/1	01	Tampo   Tapa   Top	800x295x15
04	1/1	01	Fundo   Fondo   Bottom	792x434x3
05	1/1	01	Porta Basculante   Puerta Basculante   Basculating Door	796x405x15

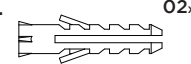
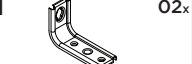
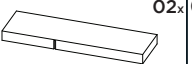
Ferragens | Herrajes | Hardware

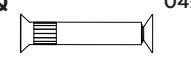
<b>A</b>  Parafuso 5,0x50mm FLA. Tornillo 5,0x50mm FLA. Screw 5,0x50mm FLA.	02x	<b>B</b>  Parafuso 3,5x40mm CHT. Tornillo 3,5x40mm CHT. Screw 3,5x40mm CHT.	08x	<b>C</b>  Parafuso 3,5x14mm FLA. Tornillo 3,5x14mm FLA. Screw 3,5x14mm FLA.	08x	<b>D</b>  Parafuso 3,5x12mm CHT. Tornillo 3,5x12mm CHT. Screw 3,5x12mm CHT.	03x	<b>E</b>  Parafuso União 15mm Tornillo Unión 15mm Union Screw 15mm	04x
<b>F</b>  Cavilha 8x25mm Cinta 8x25mm Dowel 8x25mm	08x	<b>G</b>  Prego 10x10mm Clavo 10x10mm Nail 10x10mm	24x	<b>H</b>  Puxador ALX179 - 796mm Tirador ALX179 - 796mm ALX179 - 796mm Handle	01x	<b>I</b>  Kit Pistão a Gás 60N Kit Pistón a Gas 60N 60N Gas Piston Kit	01x	<b>J</b>  Calço metal médio 0mm Calzado metálico medio 0mm Metal shim 0mm	02x
<b>K</b>  Dobradiça metal 35mm Alta Bisagras metálicas 35mm Alta Metal hinge 35mm High	02x	<b>L</b>  Bucha plástica 8mm Bucha de plástico 8mm 8mm plastic bushing	02x	<b>M</b>  Suporte de fixação Soporte de fijación Mounting bracket	02x	<b>N</b>  Proteção para cantoneira Ángulo de protección Protection angle	02x	<b>O</b>  Sachê de cola Bolsa de pegamento Glue bag	01x
<b>P</b>  Adesivo tapa parafuso 10mm Adhesivo tapón de tornillo 10mm Bolt cover adhesive 10mm	08x	<b>Q</b>  Parafuso União 30mm Tornillo Unión 30mm Union Screw 30mm	04x						



O parafuso (Q) deve ser usada somente quando este módulo for acoplado a outro módulo componível Henn.



El tornillo (Q) se debe utilizar sólo cuando el módulo está conectado a otro módulo componible Henn.



The screw (Q) should be used only when this module is attached to another Henn modular module.

RECOMENDAÇÃO

Para fixar o móvel na parede usar o suporte de fixação (M), o parafuso 3,5x14mm FLA (C), a Bucha 8mm (L) e o parafuso 5,0x50mm FLA (A).

RECOMENDACIÓN

Para conectar el móvil a la pared con el soporte (M), tornillo 3,5 x14mm FLA (C), el casquillo de 8 mm (L) y el 5,0 x50mm tornillo FLA (A).

RECOMMENDATION

To fix the furniture to the wall use the fixing bracket (M), the 3.5x14mm FLA (C) screw, the 8mm bushing (L) and the 5.0x50mm FLA (A).

Item	Caixa Caja Box	Qtd Ctd Qty	Descrição   Descripción   Description	Medidas (mm)   Dimensiones (mm)   Size (measurements) (mm)
01	1/1	01	Base   Base   Base	1200x490x15
02	1/1	01	Lateral esquerda   Lateral izquierda   Left side	715x490x15
03	1/1	01	Divisão   División   Division	655x490x15
04	1/1	01	Prateleira   Estante   Shelf	784x400x15
05	1/1	01	Travessa frontal   Travesaño frontal   Front crossbar	1169x60x15
06	1/1	01	Travessa traseira   Travesaño trasero   Rear bumper	1169x60x15
07	1/1	01	Lateral direita   Lateral derecha   Right side	715x490x15
08	1/1	01	Pilastra da Porta   Pilastra Puerta   Pilaster door	654x60x15
09	1/1	01	Fundo menor   Fondo menor   Minor fund	727x389x3
10	1/1	02	Fundo maior   Fondo mayor   Greater Fund	803x363x3
11	1/1	02	Porta   Puerta   Door	680x396x15
12	1/1	01	Frente de Gaveta Maior   Frente de cajón más grande   Larger Drawer Front	396x326x15
13	1/1	02	Lado de gaveta Maior   Lado del cajón más grande   Larger drawer side	400x180x15
14=18	1/1	01	Fundo de gaveta   Fondo de cajón   Bottom of drawer	411x326x3
15	1/1	01	Ripa de Trás Maior   Tablilla trasera más grande   Larger rear clapboard	345x180x15
16	1/1	02	Frente de gaveta   Frente de cajón   Front of drawer	396x149x15
17	1/1	04	Lado de Gaveta   Lado del cajón   Drawer Side	400x90x15
18=14	1/1	02	Fundo de gaveta   Fondo de cajón   Bottom of drawer	411x326x3
19	1/1	02	Ripa de trás   Malla detrás   Rear lath	345x90x15
20	1/1	01	Travessa Sustentação   Travessa Ayuda   Support Travessa	1190x50x15

**HENN**

Ind. e Com. de Móveis Henn  
Mondai - SC - Brasil

+55 49 3674.3500

@moveishenn  
www.henn.com.br

**INSTRUÇÕES DE MONTAGEM**

INSTRUCCIONES DE MONTAJE  
ASSEMBLY INSTRUCTIONS

**Balcão Pia 02 Portas 03 Gavetas Belize**  
**Fregadero 02 Puertas 03 Cajones Belize | Counter Sink 02 Doors 03 Drawers Belize**  
**C508-131 Cinza**

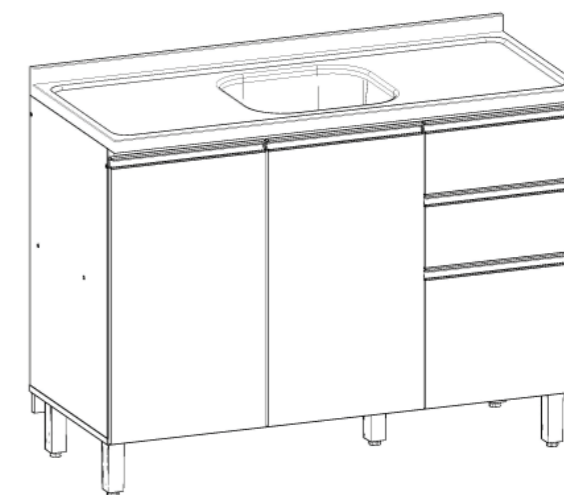
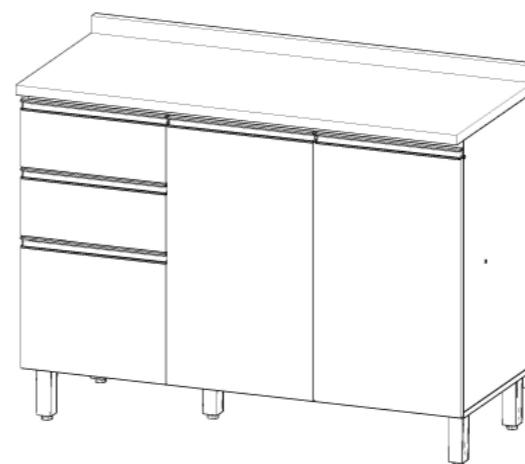
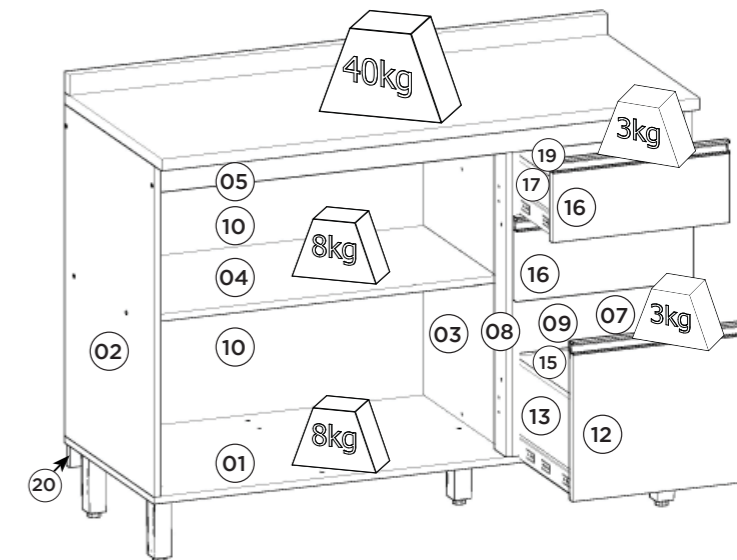
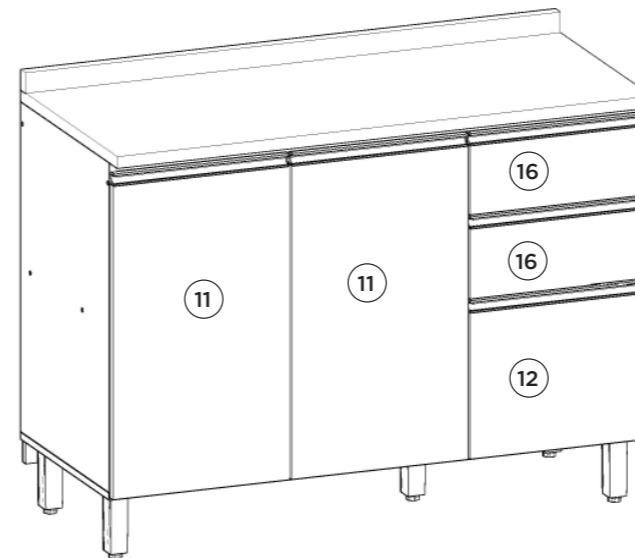

Pesos máximos recomendados com carga distribuída  
Peso máximo recomendado con la carga distribuída  
Recommended maximum weights with evenly distributed.

Ferragens | Herrajes | Hardware

<b>A</b> Parafuso 7,0x40mm CHT. Tornillo 7,0x40mm CHT. Screw 7,0x40mm CHT.	<b>B</b> Parafuso 5,0x50mm FLA. Tornillo 5,0x50mm FLA. Screw 5,0x50mm FLA.	<b>C</b> Parafuso 4,5x50mm CHT. Tornillo 4,5x50mm CHT. Screw 4,5x50mm CHT.	<b>D</b> Parafuso 4,0x25mm CHT. Tornillo 4,0x25mm CHT. Screw 4,0x25mm CHT.	<b>E</b> Parafuso 3,5x40mm CHT. Tornillo 3,5x40mm CHT. Screw 3,5x40mm CHT.	<b>F</b> Parafuso 3,5x14mm FLA. Tornillo 3,5x14mm FLA. Screw 3,5x14mm FLA.
<b>G</b> Parafuso 3,5x12mm CHT. Tornillo 3,5x12mm CHT. Screw 3,5x12mm CHT.	<b>H</b> Parafuso 3,0x30mm CHT. Tornillo 3,0x30mm CHT. Screw 3,0x30mm CHT.	<b>I</b> Prego 10x10mm Clavo 10x10mm Nail 10x10mm	<b>J</b> Fixador de fundos Fijador de fondos Bottom fixer	<b>K</b> Cavilha 8x25mm Cinta 8x25mm Dowel 8x25mm	<b>L</b> Parafuso minifix Tornillo minifix Minifix bolt
<b>M</b> Tambor minifix Tambor minifix Minifix drum	<b>N</b> Pé 145mm x 42mm Pie 145mm x 42mm Foot 145mm x 42mm	<b>O</b> Cantoneira plástica Cantenera plástica Plastic angle brackets	<b>P</b> Calço Removível Calzado extraíble Removable Shim	<b>Q</b> Dobradilha SlideOn Baixa Amortecedor 35mm Bisagra SlideOn Baja Amortiguador 35mm Low SlideOn Hinge 35mm Shock Absorber	<b>R</b> Puxador MOV4083 - 396mm Tirador MOV4083 - 396mm MOV4083 - 396mm Handle
<b>S</b> Corrediça telescópica Diapositivas telescópicas Telescopic slides	<b>T</b> Parafuso União 30mm Tornillo Unión 30mm Union Screw 30mm	<b>U</b> Bucha plástica 8mm Bucha de plástico 8mm 8mm plastic bushing	<b>V</b> Divisor talheres 398x313mm Divisor cubiertos 398x313mm Cutlery divider 398x313mm	<b>W</b> Sachê de cola Bolsa de pegamento Glue bag	<b>X</b> Giz de correção Tiza de corrección Chalk of correction
<b>Y</b> Suporte de fixação Soporte de fijación Mounting bracket	<b>Z</b> Proteção para cantoneira Ángulo de protección Protection angle	<b>AA</b> Adesivo tapa parafuso 17mm Adhesivo tapón de tornillo 17mm Bolt cover adhesive 17mm	<b>AB</b> Adesivo tapa parafuso 10mm Adhesivo tapón de tornillo 10mm Bolt cover adhesive 10mm	<b>AC</b> Etiqueta resinada Henn Etiqueta resinada Henn Henn resin label	

Requisitos para montagem  
Requisitor para la montaje  
Assembly Requirements

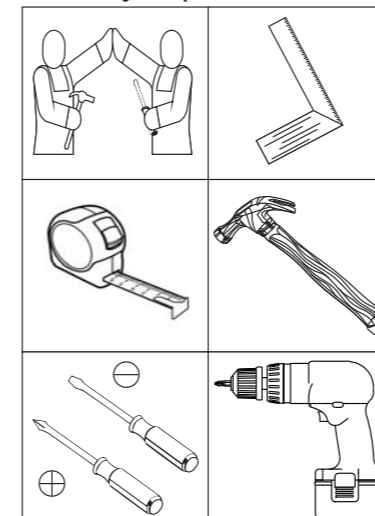

Imagens meramente ilustrativas  
Imágenes meramente ilustrativas  
Images for illustration only

**RECOMENDAÇÃO**

Para fixar o móvel na parede usar o suporte de fixação (Y), o parafuso 3,5x14mm FLA (F), a Bucha 8mm (U) e o parafuso 5,0x50mm FLA (B).

**RECOMENDACIÓN**

Para conectar el móvil a la pared con el soporte (Y), tornillo 3,5 x14mm FLA (F), el casquillo de 8 mm (U) y el 5,0 x50mm tornillo FLA (B).

**RECOMMENDATION**

To fix the furniture to the wall use the mounting bracket (Y), the 3.5x14mm FLA (F) screw, the 8mm bushing (U) and the 5.0x50mm FLA screw (B).

**AVISO**

Para limpeza de seu móvel, use uma flanela seca ou umedecida, e não utilize produtos químicos que possam danificar seu produto.

**SISTEMA DE MONTAGEM**

O sistema de montagem dos produtos, funciona de acordo com a ordem crescente dos números indicados no desenho. Ex: 01, 02, 03, 04... até a conclusão da montagem.

**ADVERTENCIA**

Para limpieza de su móvil, use una flanela seca o húmeda, y no utilice productos químicos que puedan dañar su producto.

**SISTEMA DE MONTAJE**

El sistema de montaje de los productos funciona de acuerdo con el orden creciente de los números indicados en el dibujo. Ej.: 01, 02, 03, 04... hasta la conclusión del montaje.

**NOTICE**

To clean your furniture, use a dry or wet cloth, and do not use chemicals that may damage your product.

**ASSEMBLY SYSTEM**

The products' assembly system works according to the increasing order of the indicated numbers. For example: 01, 02, 03, 04 ... to the end of the assembly.

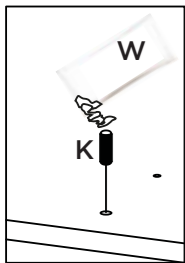
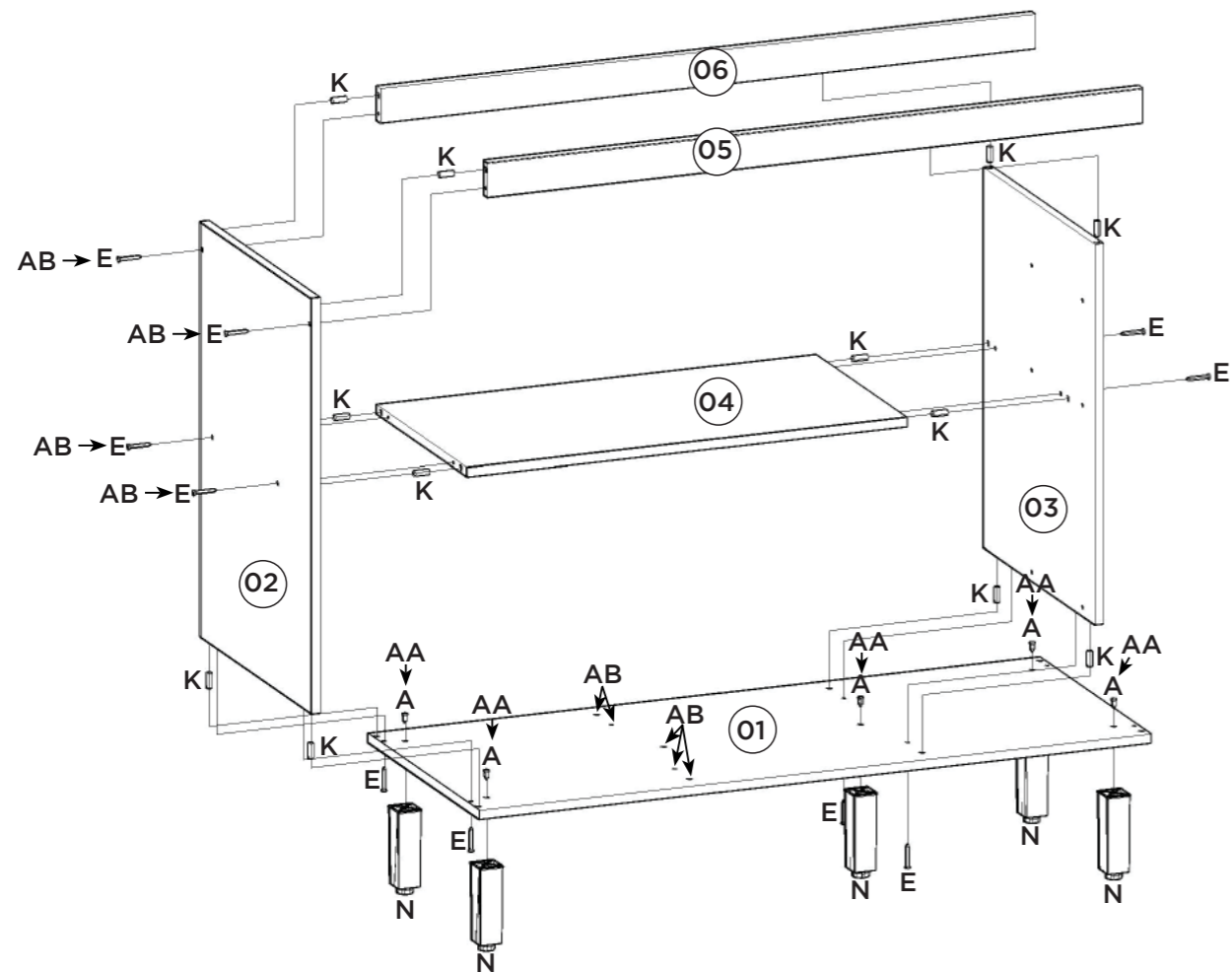

Utilizar o sachê de cola (W) em todas as cavilhas (K) do produto.

Con el pegamento sobre (W) en todos los pernos (K) producto.

Use the glue sachet (W) on all the pegs (K) of the product.

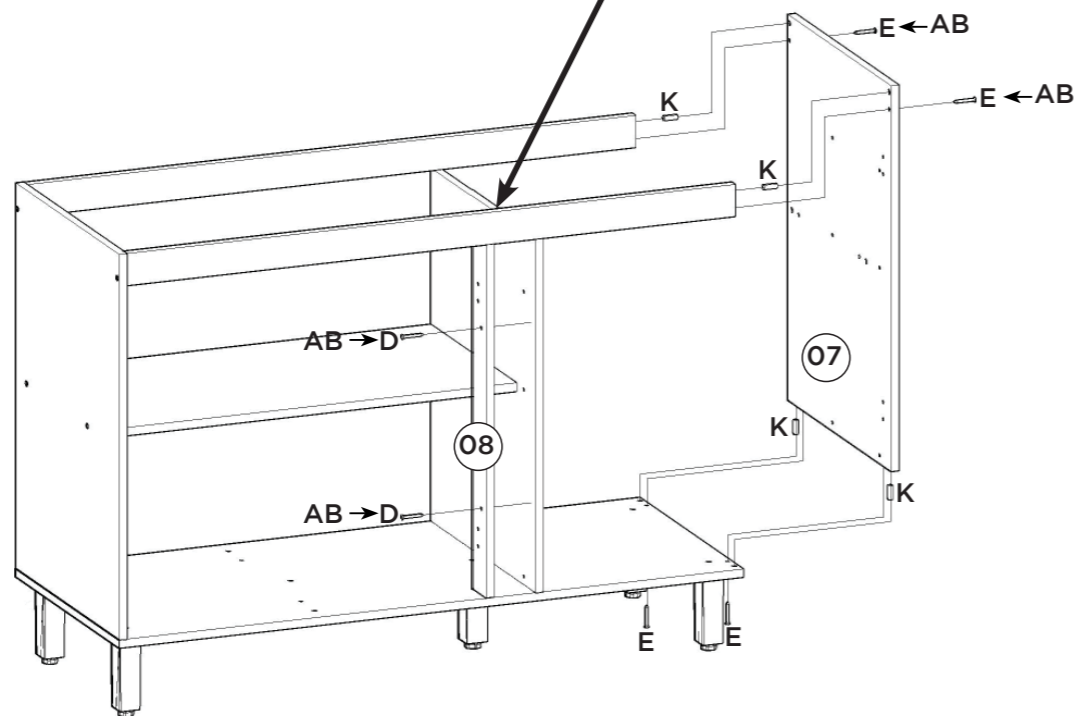
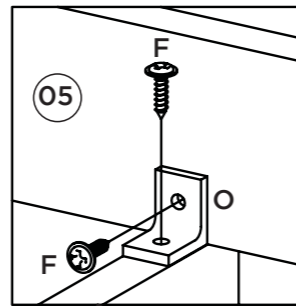

A pilastra da porta (08) deve estar alinhada com a divisão (03).

El pilar de la puerta (08) debe estar alineada con la división (03).

The door pillar (08) must be aligned with the partition (03).

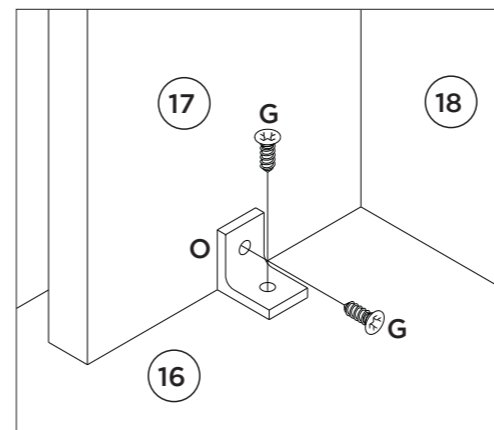
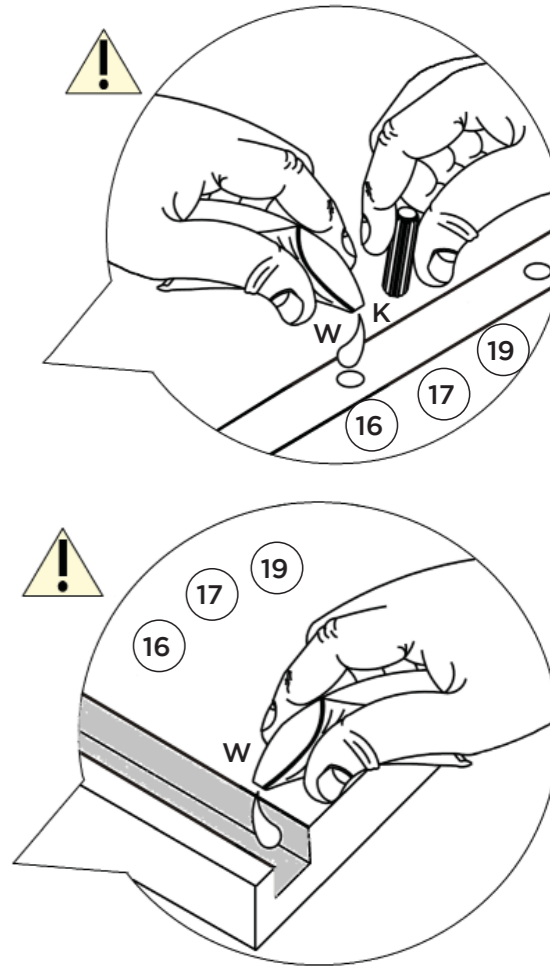
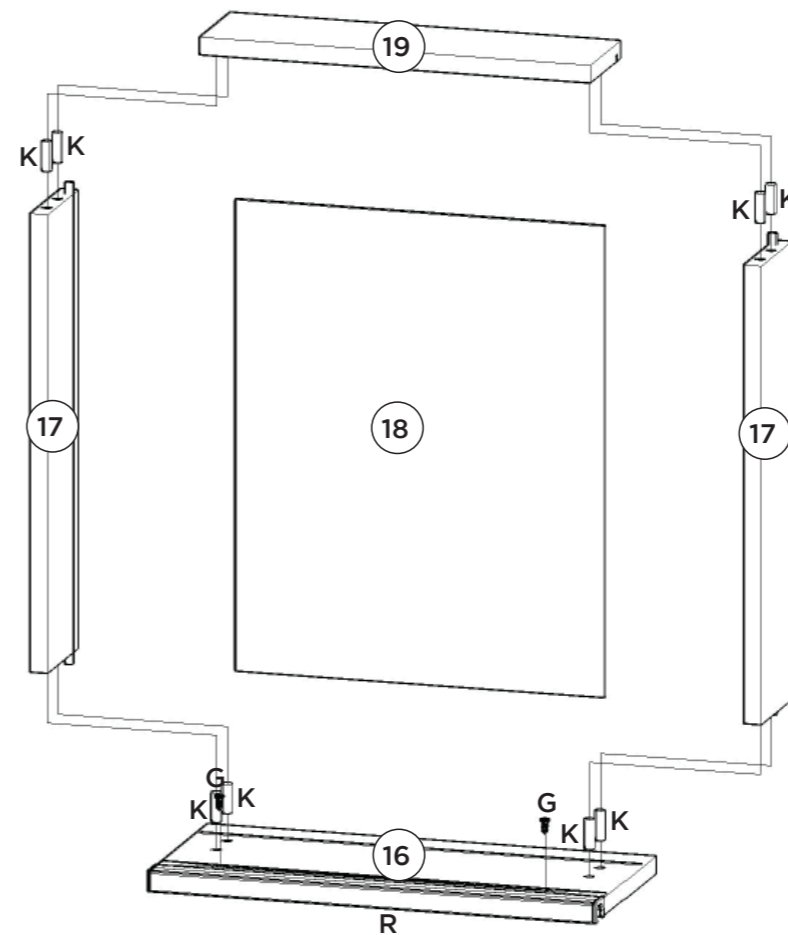

A corrediça (S) deverá ser alinhada com a parte de baixo do lado de gaveta (17).

La carcasa (S) será alineada con la parte de por el lado del cajón (17).

The slide (S) should be aligned with the underside of the drawer side (17).

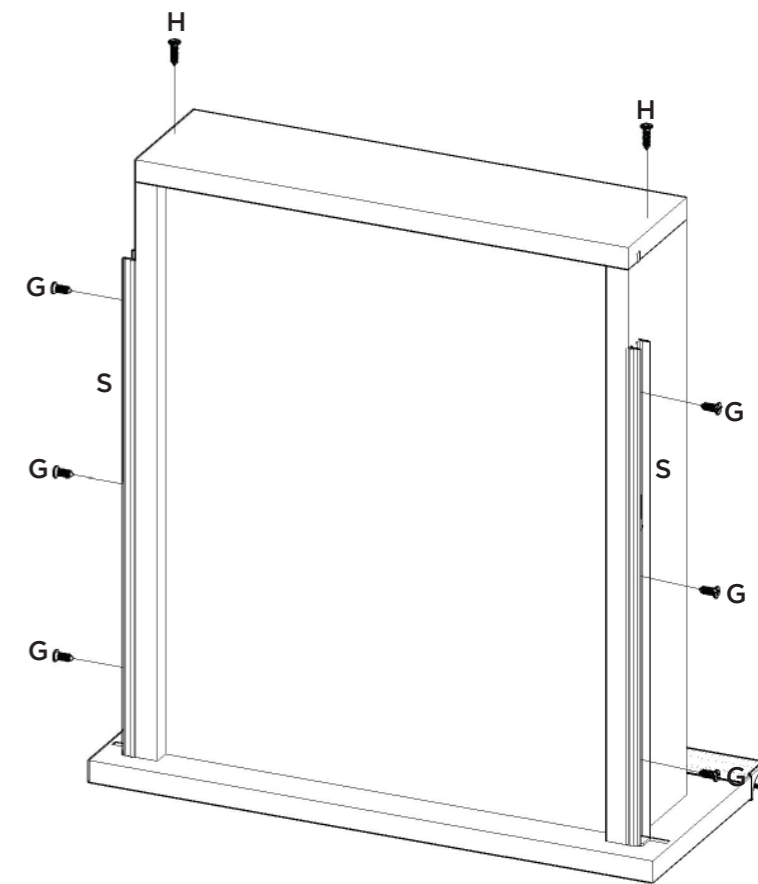

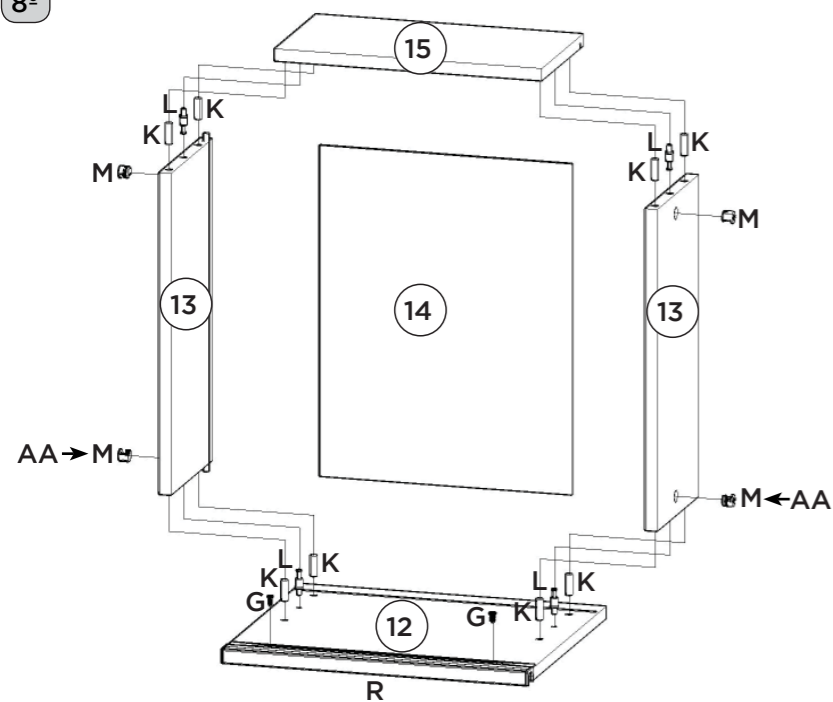
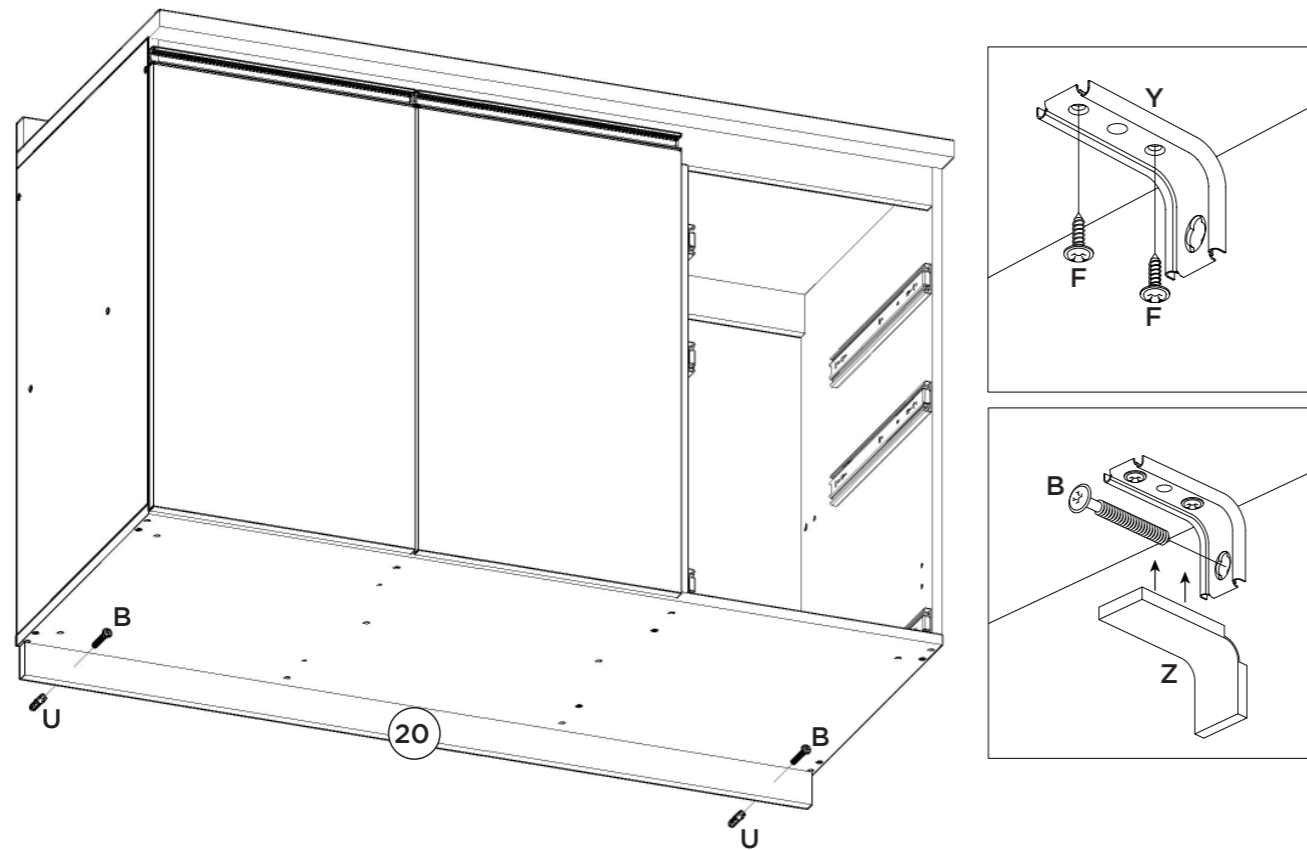

Parede  
pared  
Wall

A corredeira (S) deverá ser alinhada com a parte de baixo do lado de gaveta (13).

La carcasa (S) será alineada con la parte de por el lado del cajón (13).

The slide (S) should be aligned with the underside of the drawer side (13).

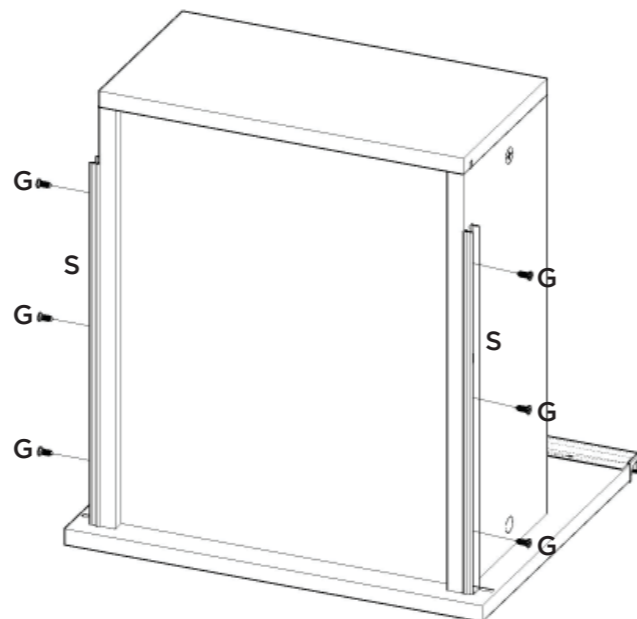

Esse tampo é opcional e é vendido separadamente (C905-33).

Esta vez es opcional y se vende por separado (C905-33).

This top is optional and is sold separately (C905-33).

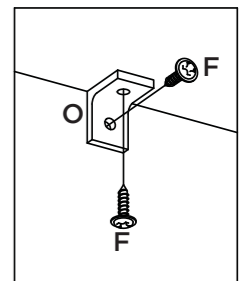
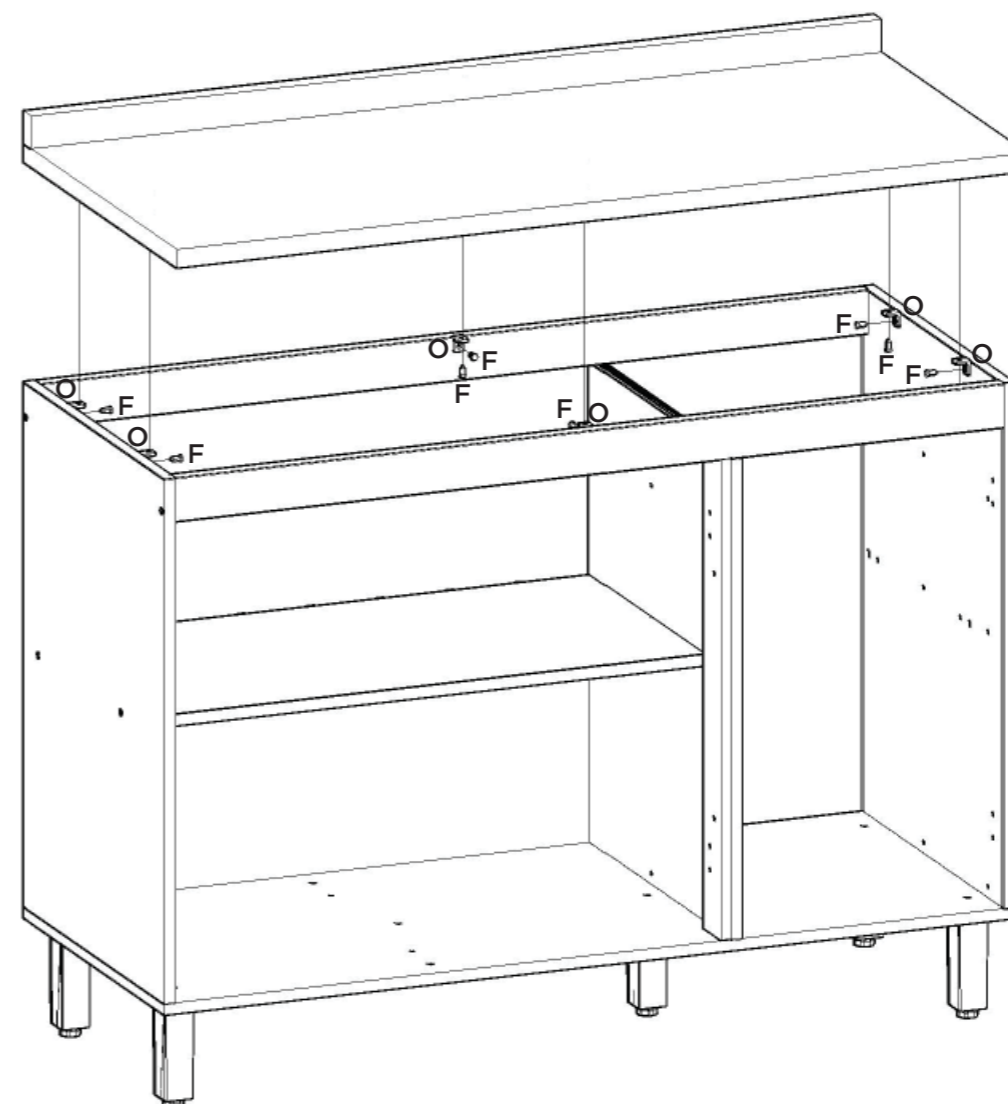
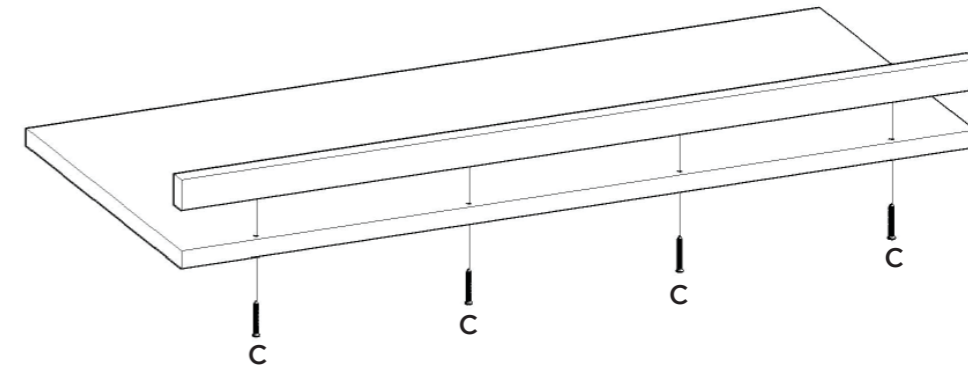

Caso o móvel seja montado com a opção do tampo, fixar o mesmo com 06 cantoneiras (O) e os parafusos 3,5x14mm (F).

Si se monta el auricular con la opción de la cubierta, fijarlo con Los ángulos 06 (O) y 3,5 x14mm tornillos (F).

If the furniture is to be installed with the top cover option, fix it with 06 (O) and 3.5x14mm screws (F).

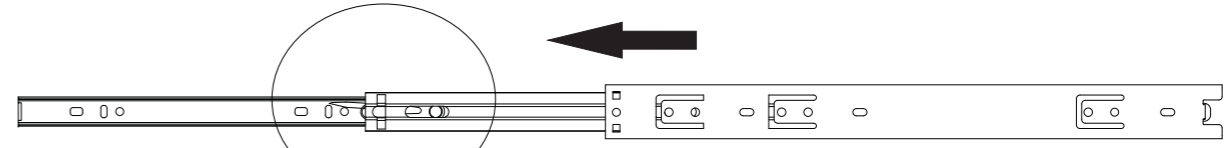
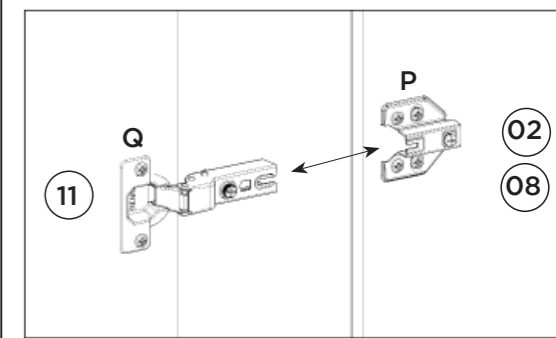
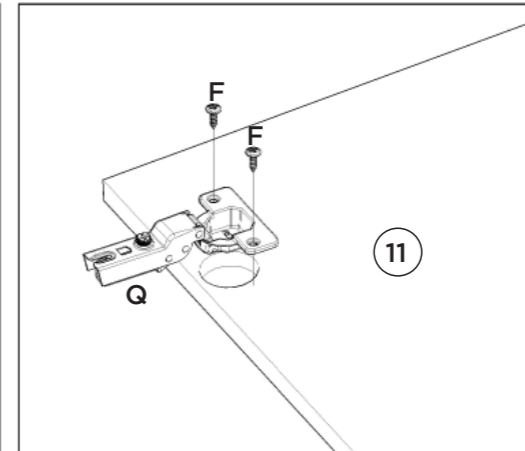
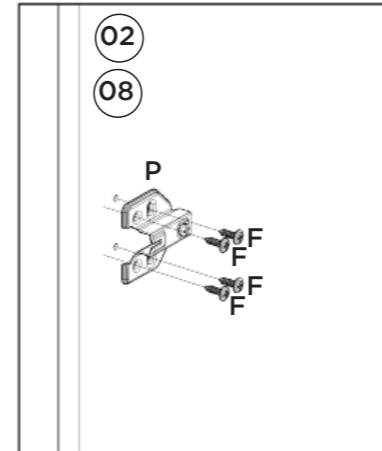
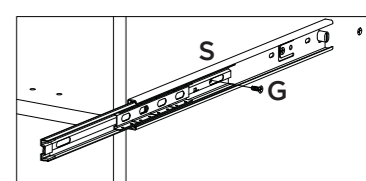
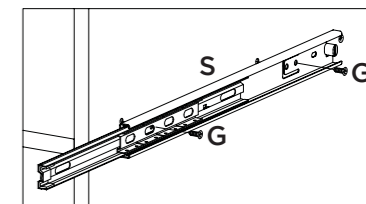
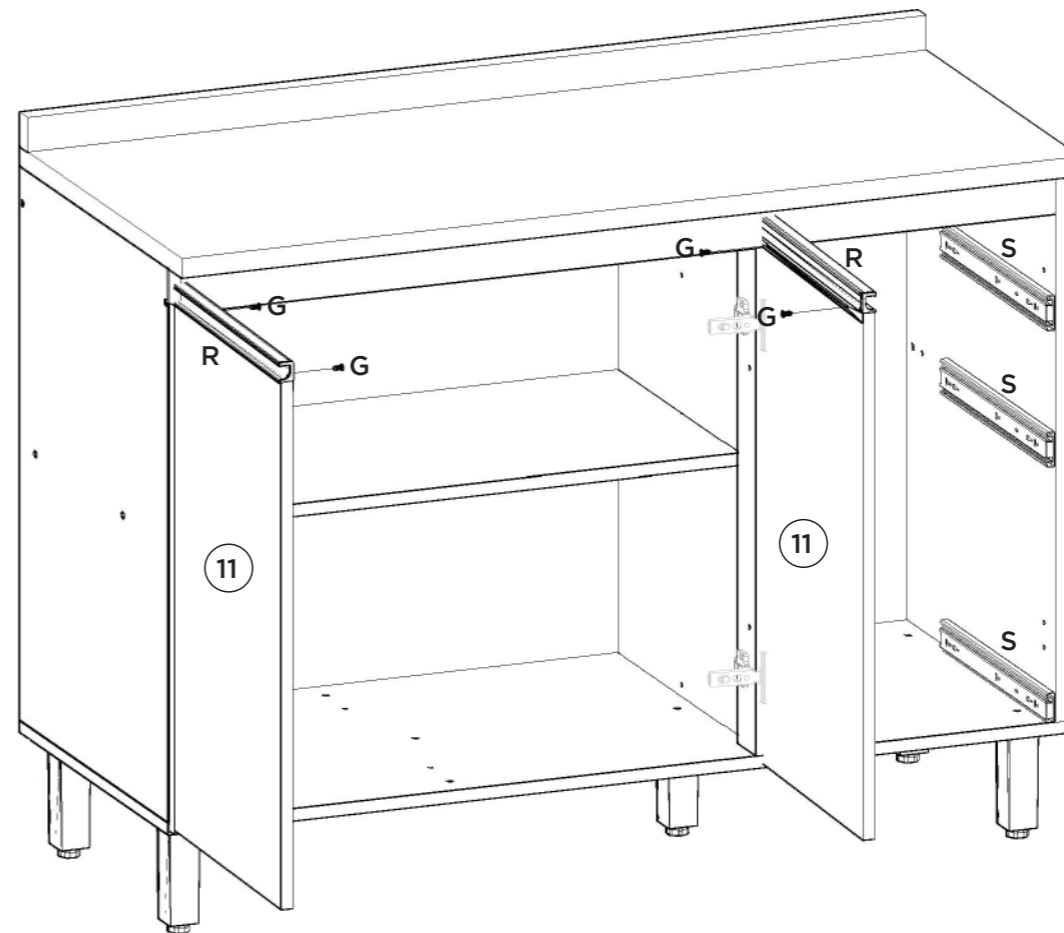
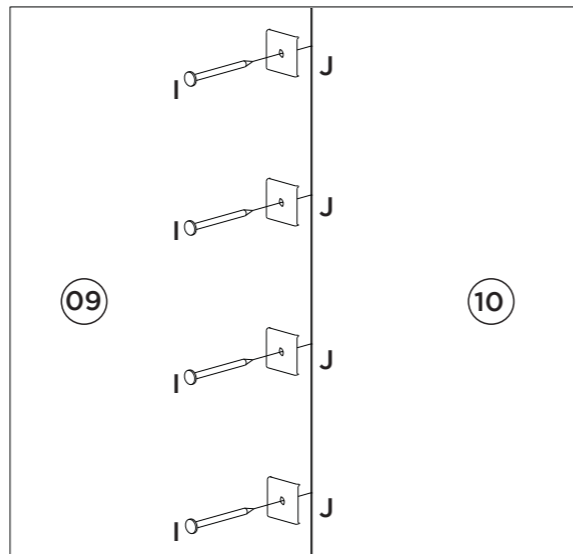
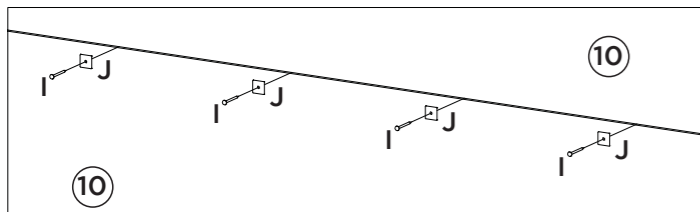
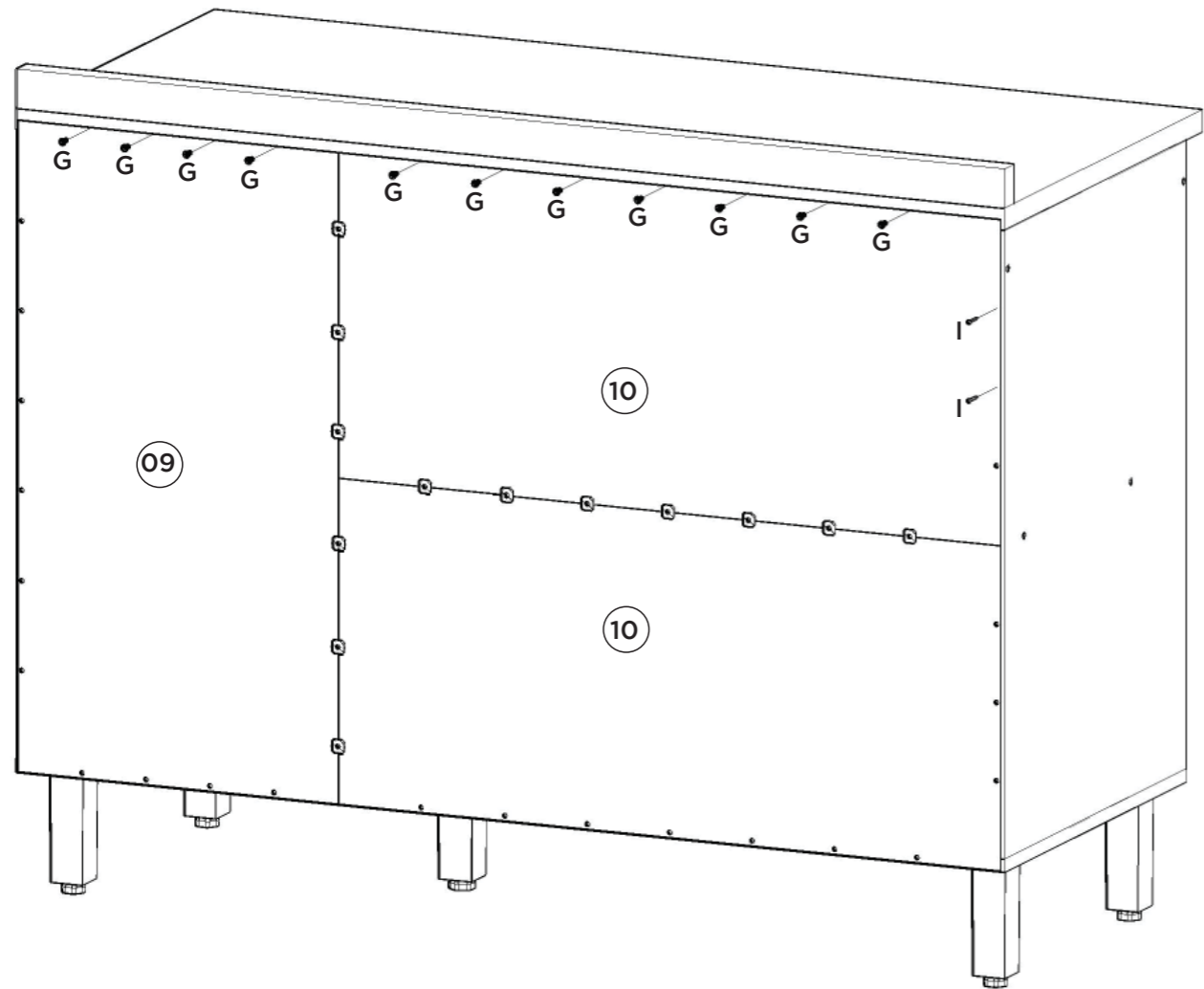

Para a desmontagem da correia siga a instrução ao lado.

Para el desmontaje seguimiento de diapositivas la instrucción siguiente a.

For the dismount of the sliding onem follows the instruction aside.

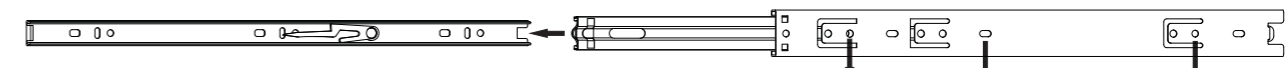
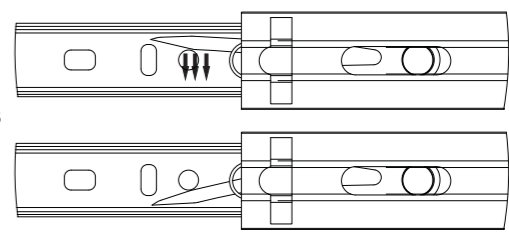

Fixar as correias nessas furações  
Fijar las diapositivas de estos agujeros  
Fix slides in these drillings