

Torre Quente 2 Fornos Belize Torre Caliente 2 Hornos Belize | Hot Tower 2 Belize Ovens c C513-131 - Cinza

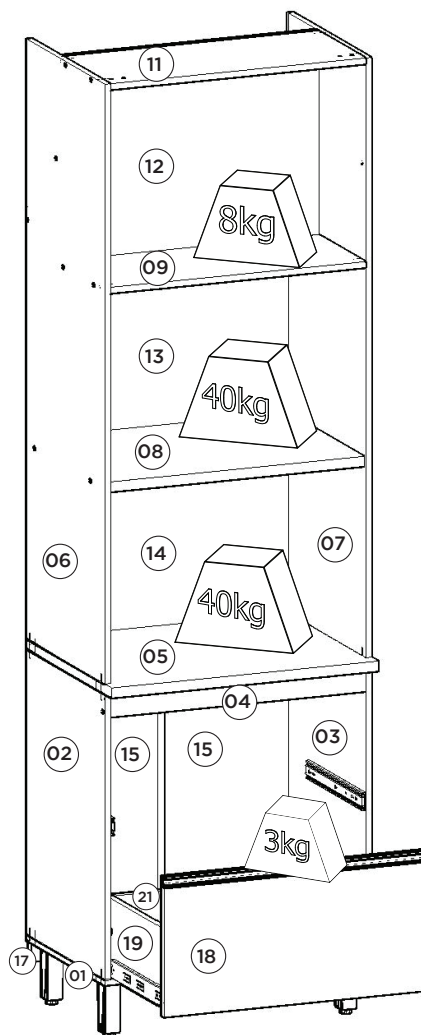

Pesos máximos recomendados com carga distribuída
Peso máximo recomendado con la carga distribuida
Recommended maximum weights with evenly distributed.

Requisitos para montagem Requisitor para la montaje Assembly Requirements

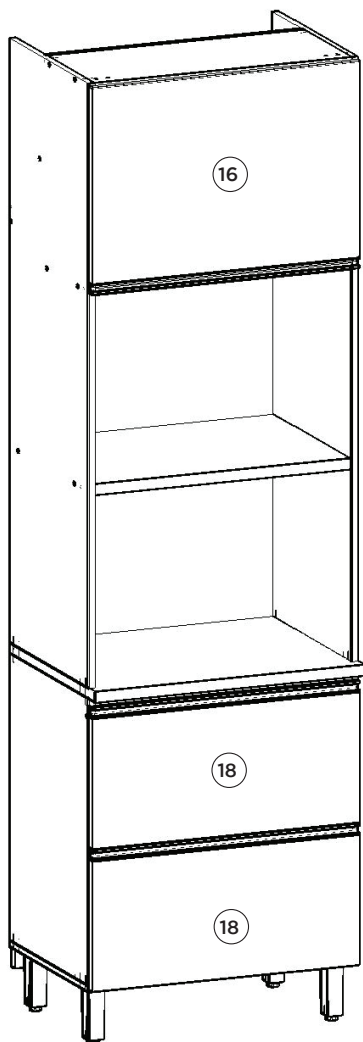
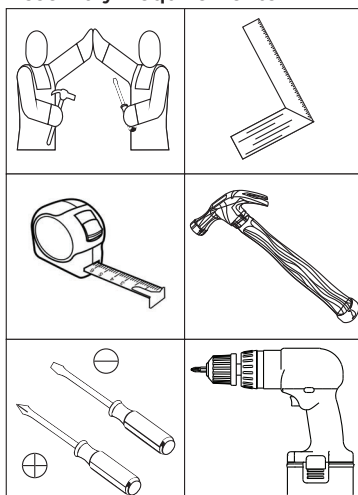

Imagens meramente ilustrativas
Imágenes meramente ilustrativas
Images for illustration only

AVISO

Para limpeza de seu móvel, use uma flanela seca ou umedecida, e não utilize produtos químicos que possam danificar seu produto.

SISTEMA DE MONTAGEM

O sistema de montagem dos produtos, funciona de acordo com a ordem crescente dos números indicados no desenho. Ex: 01, 02, 03, 04... até a conclusão da montagem.

ADVERTENCIA

Para limpieza de su móvil, use una flanela seca o húmeda, y no utilice productos químicos que puedan dañar su producto.

SISTEMA DE MONTAJE

El sistema de montaje de los productos funciona de acuerdo con el orden creciente de los números indicados en el dibujo. Ej.: 01, 02, 03, 04... hasta la conclusión del montaje.

NOTICE

To clean your furniture, use a dry or wet cloth, and do not use chemicals that may damage your product.

ASSEMBLY SYSTEM

The products' assembly system works according to the increasing order of the indicated numbers. For example: 01, 02, 03, 04 ... to the end of the assembly.

1°

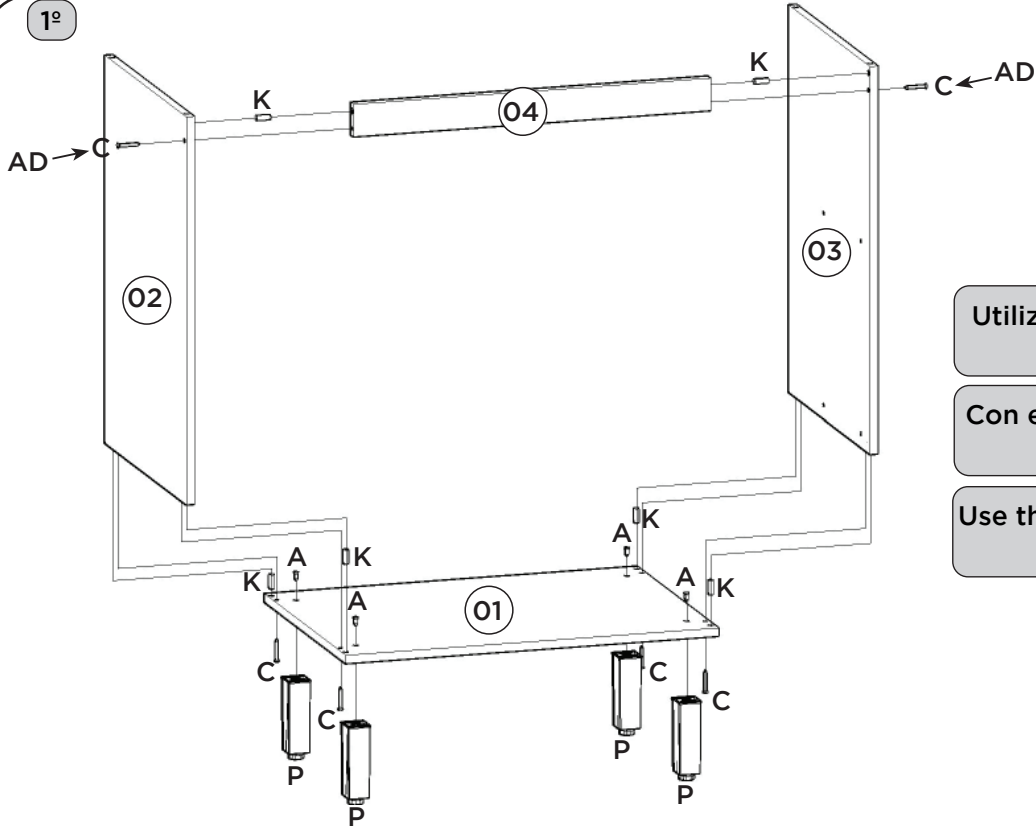

Utilizar o sachê de cola (AA) em todas as cavilhas (K) do produto.

Con el pegamento sobre (AA) en todos los pernos (K) producto.

Use the glue sachet (AA) on all the pegs (K) of the product.

2°

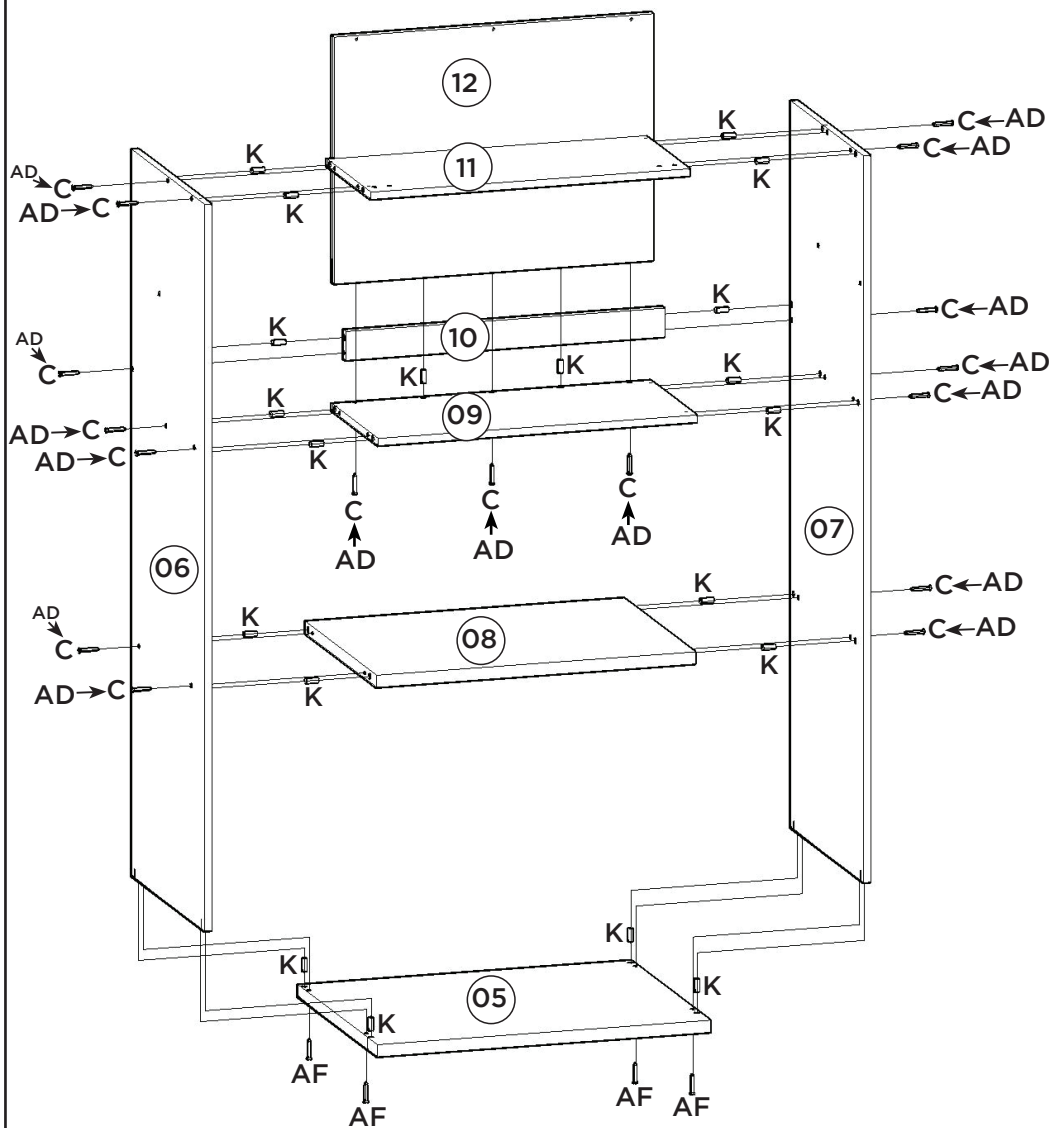

3°

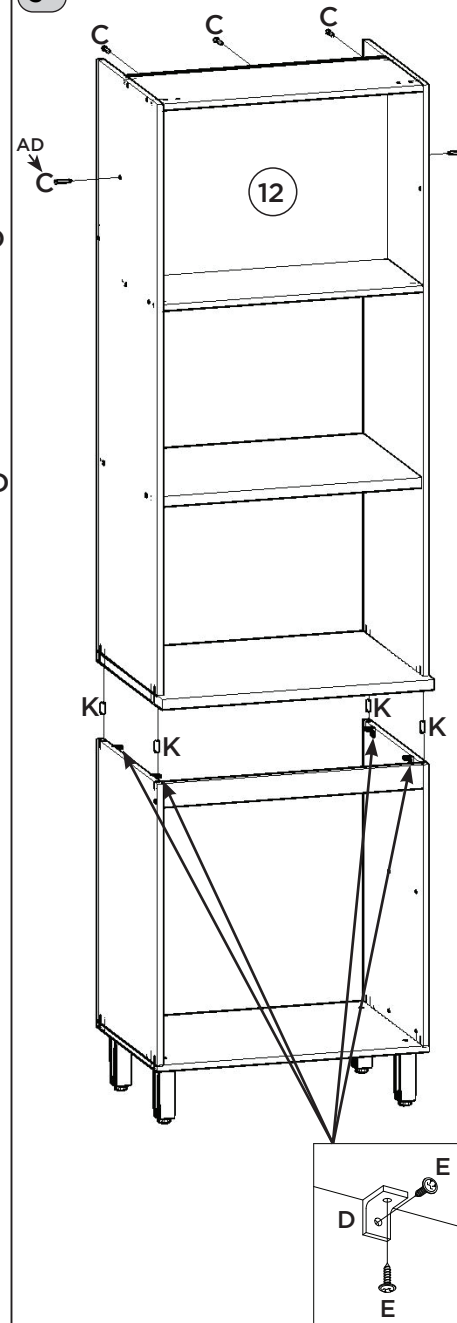

4º

ATENÇÃO: Por questão de segurança, recomendamos a não utilização do Fundo (12) caso o espaço seja utilizado por forno elétrico ou forno embutido, dessa forma, haverá melhor propagação do calor, evitando danos em seu móvel.

ADVERTENCIA: Por razones de seguridad, se recomienda no utilizar el Fondo (12) si el espacio es utilizado por horno eléctrico o una función de horno, de esta manera no será mejor propagación del calor, evitando el daño a su móvil.

ATTENTION: For safety reasons, we recommend not using the Fund (12) if the space is used by an electric oven or built-in oven, in this way, there will be better propagation of the heat, avoiding damage to your furniture.

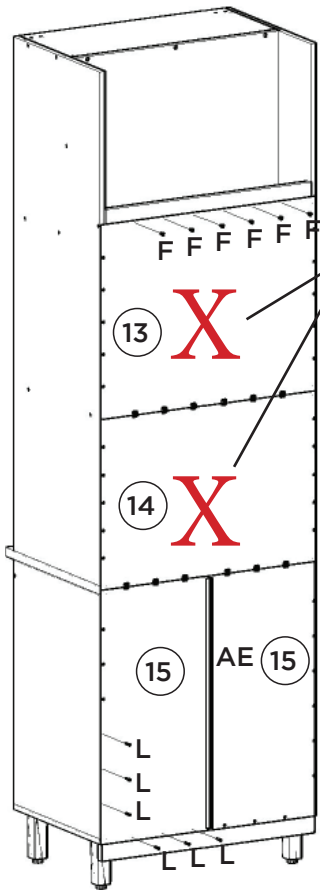

5º



Video: Instalar e regular Dobradiças

Video: Instale y ajuste las bisagras

Video: Install and adjust hinges

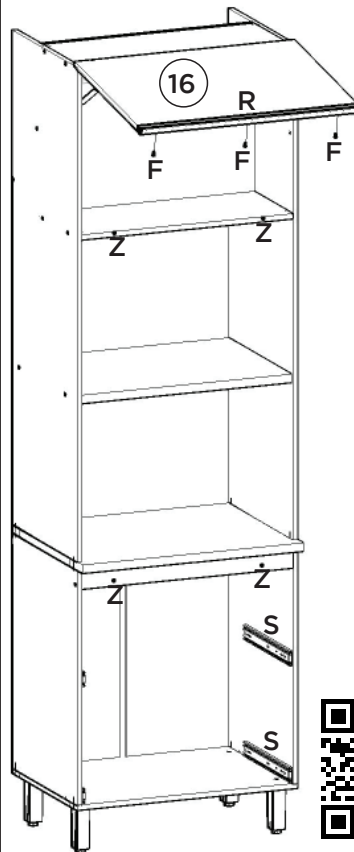

Video: Dicas para instalar o Kit Pistão à Gás

Video: Consejos para instalar el kit de pistón de gas

Video: Tips for installing the Gas Piston Kit



Video: Dicas para fixar a Corrediça

Video: Consejos para arreglar la diapositiva

Video: Tips for Fixing the Slide

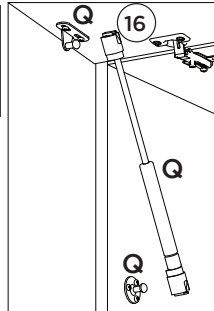
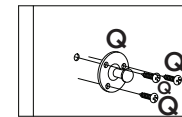
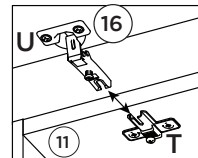
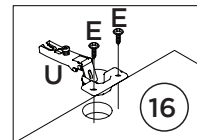
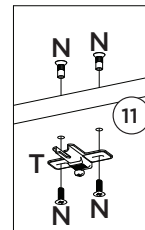
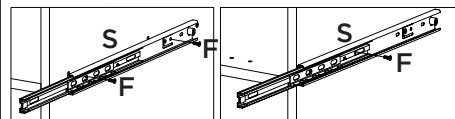

6º Opção Suspensa / Opción suspendida / Suspended Option

Parede / pared / Wall

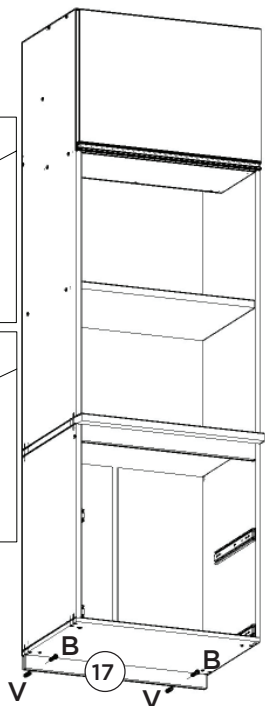
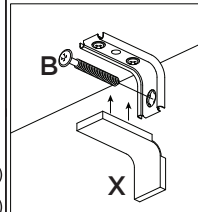
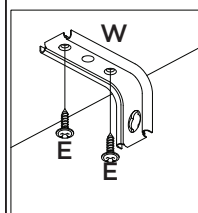

7º Gaveta 02x / Cajone 02x / Drawer 02x

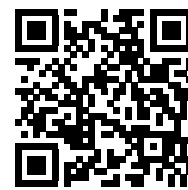
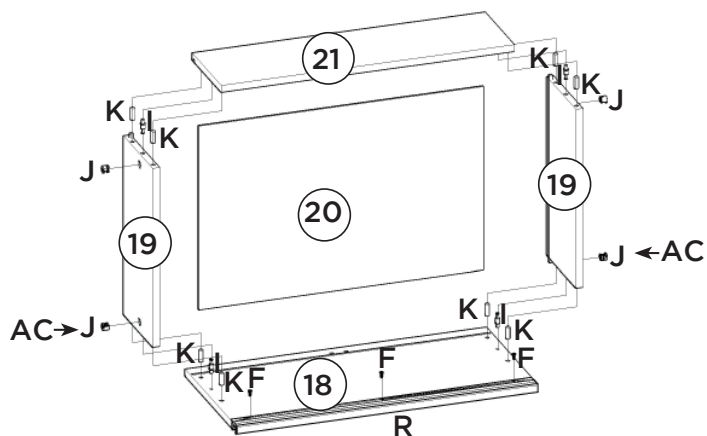

Video: Dicas para fixar o Minifix





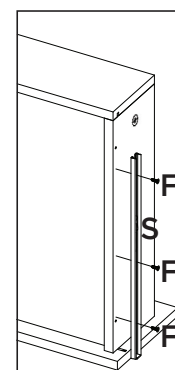
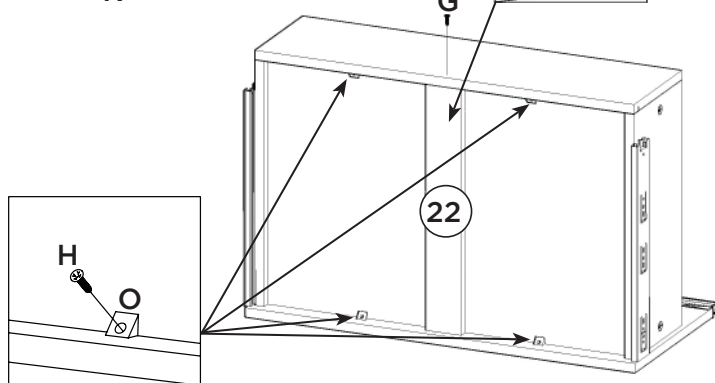





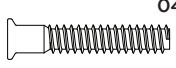
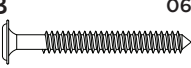

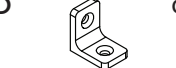
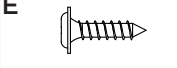
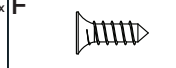
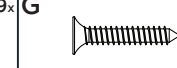
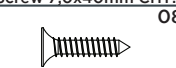
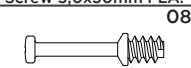

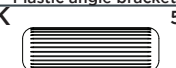
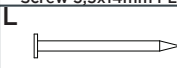

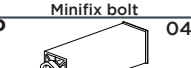
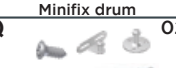
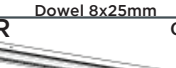

Video: Consejos para arreglar Minifix

Video: Tips for Fixing Minifix

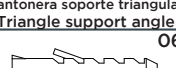

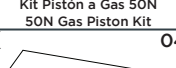
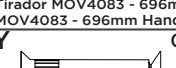
Item	Caixa Caja Box	Qty Ctd Qty	Descrição Descripción Description	Medidas (mm) Dimensions (mm) Size (measurements) (mm)
01	2/2	01	Base Base Base	700x490x15
02	1/2	01	Lateral Esquerda Inferior Lateral Izquierda Inferior Left Side Lower	715x490x15
03	1/2	01	Lateral Direita Inferior Lateral Derecha Inferior Right Side Bottom	715x490x15
04=10	1/2	01	Travessa Frontal Travesaño delantero Front cross member	669x60x15
05	2/2	01	Tampo 25mm Tapa 25mm Top 25mm	700x533x25
06	1/2	01	Lateral Esquerda Superior Lado Izquierdo Superior Upper Left Side	1500x490x15
07	1/2	01	Lateral Direita Superior Lateral Derecha Superior Right Side Superior	1500x490x15
08	2/2	01	Prateleira 25mm Estantería 25mm Shelf 25mm	669x480x25
09	2/2	01	Prateleira Central Prateleira Central Central Shelf	669x310x15
10=04	1/2	01	Travessa Frontal Travesaño delantero Front cross member	669x60x15
11	2/2	01	Tampo Tapa Top	669x295x15
12	2/2	01	Fundo 15mm 15 mm inferior Bottom 15mm	669x510x15
13	2/2	01	Fundo Superior Fondo superior Superior background	693x566x3
14	2/2	01	Fundo central Fondo central Central fund	693x496x3
15	1/2	02	Fundo Cru Fondo Crudo Raw Background	742x343x3
16	1/2	01	Porta Basculante Puerta Basculante Tilting Door	696x490x15
17	1/2	01	Travessa Sustentação Travessa Ayuda Support Travessa	690x50x15
18	1/2	02	Frente de gaveta Frente de cajón Front of drawer	696x326x15
19	1/2	04	Lado de Gaveta Lado del cajón Drawer Side	400x180x15
20	1/2	02	Fundo de gaveta Fondo de cajón Bottom of drawer	625x411x3
21	1/2	02	Ripa de trás Malla detrás Rear lath	644x180x15
22	1/2	02	Ripa Estrutural Gaveta Ripa Estructural Cajón Drawer Structural Clamp	400x60x15

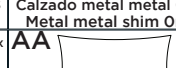
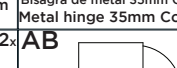
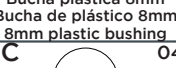
Ferragens | Herrajes | Hardware

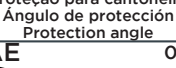
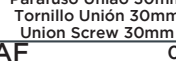
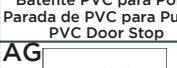
A  Parafuso 7,0x40mm CHT. Tornillo 7,0x40mm CHT. Screw 7,0x40mm CHT.	B  Parafuso 5,0x50mm FLA. Tornillo 5,0x50mm FLA. Screw 5,0x50mm FLA.	C  Parafuso 3,5x40mm CHT. Tornillo 3,5x40mm CHT. Screw 3,5x40mm CHT.	D  Cantoneira plástica Cantoneira plástica Plastic angle brackets	E  Parafuso 3,5x14mm FLA. Tornillo 3,5x14mm FLA. Screw 3,5x14mm FLA.	F  Parafuso 3,5x12mm CHT. Tornillo 3,5x12mm CHT. Screw 3,5x12mm CHT.	G  Parafuso 3,0x30mm CHT. Tornillo 3,0x30mm CHT. Screw 3,0x30mm CHT.
H  Parafuso 3,0x16mm CHT. Tornillo 3,0x16mm CHT. Screw 3,0x16mm CHT.	I  Parafuso minifix Tornillo minifix Minifix bolt	J  Tambor minifix Tambor minifix Minifix drum	K  Cavilha 8x25mm Cinta 8x25mm Dowel 8x25mm	L  Prego 10x10mm Clavo 10x10mm Nail 10x10mm	M  Fixador de fundos Fijador de fondos Bottom fixer	N  Parafuso União 15mm Tornillo Unión 15mm Union Screw 15mm
O  Cantoneira suporte triangular Cantoneira soporte triangular Triangle support angle	P  Pé 145mm x 42mm Pie 145mm x 42mm Foot 145mm x 42mm	Q  Kit Pistão a Gás 50N Kit Pistón a Gas 50N 50N Gas Piston Kit	R  Puxador MOV4083 - 696mm Tirador MOV4083 - 696mm MOV4083 - 696mm Handle	S  Corrediça telescópica Diapositivas telescópicas Telescopic slides	T  Calço metal metal 0mm Calzado metal metal 0mm Metal metal shim 0mm	U  Dobradiça metal 35mm Colo Baixo Bisagra de metal 35mm Colo Bajo Metal hinge 35mm Colo Low
V  Buchsa plástica 8mm Buchsa de plástico 8mm 8mm plastic bushing	W  Suporte de fixação Soporte de fijación Mounting bracket	X  Proteção para cantoneira Ángulo de protección Protection angle	Y  Parafuso União 30mm Tornillo Unión 30mm Union Screw 30mm	Z  Batente PVC para Porta Parada de PVC para Puerta PVC Door Stop	AA  Sachê de cola Bolsa de pegamento Glue bag	AB  Giz de correção Tiza de corrección Chalk of correction
AC  Adesivo tampa parafuso 17mm Adhesivo tapón de tornillo 17mm Bolt cover adhesive 17mm	AD  Adesivo tampa parafuso 10mm Adhesivo tapón de tornillo 10mm Bolt cover adhesive 10mm	AE  Perfil "H" 728mm Perfil "H" 728mm Profile "H" 728mm	AF  Parafuso 4,5x50mm CHT. Tornillo 4,5x50mm CHT. Screw 4,5x50mm CHT.	AG  Etiqueta resinada Henn Etiqueta resinada Henn Henn resin label		



O parafuso (Y) deve ser usada somente quando este módulo for acoplado a outro módulo componível Henn.

RECOMENDAÇÃO

Para fixar o móvel na parede usar o suporte de fixação (W), o parafuso 3,5x14mm FLA (E), a Buchsa 8mm (V) e o parafuso 5,0x50mm FLA (B).



El tornillo (Y) se debe utilizar sólo cuando el módulo está conectado a otro módulo componible Henn.

RECOMENDACIÓN

Para conectar el móvil a la pared con el soporte (W), tornillo 3,5 x14mm FLA (E), el casquillo de 8 mm (V) y el 5,0 x50mm tornillo FLA (B).



The screw (Y) should be used only when this module is attached to another Henn modular module.

RECOMMENDATION

To fix the furniture to the wall use the mounting bracket (W), the 3.5x14mm FLA (E) screw, the 8mm bushing (V) and the 5.0x50mm FLA (B).

Item	Caixa Caja Box	Qtd Ctd Qty	Descrição Descripción Description	Medidas (mm) Dimensiones (mm) Size (measurements) (mm)
01	1/1	01	Base Base Base	1200x490x15
02	1/1	01	Lateral esquerda Lateral izquierda Left side	715x490x15
03	1/1	01	Divisão División Division	655x490x15
04	1/1	01	Prateleira Estante Shelf	784x400x15
05	1/1	01	Travessa frontal Travesaño frontal Front crossbar	1169x60x15
06	1/1	01	Travessa traseira Travesaño trasero Rear bumper	1169x60x15
07	1/1	01	Lateral direita Lateral derecha Right side	715x490x15
08	1/1	01	Pilastra da Porta Pilastra Puerta Pilaster door	654x60x15
09	1/1	01	Fundo menor Fondo menor Minor fund	727x389x3
10	1/1	02	Fundo maior Fondo mayor Greater Fund	803x363x3
11	1/1	02	Porta Puerta Door	680x396x15
12	1/1	01	Frente de Gaveta Maior Frente de cajón más grande Larger Drawer Front	396x326x15
13	1/1	02	Lado de gaveta Maior Lado del cajón más grande Larger drawer side	400x180x15
14=18	1/1	01	Fundo de gaveta Fondo de cajón Bottom of drawer	411x326x3
15	1/1	01	Ripa de Trás Maior Tablilla trasera más grande Larger rear clapboard	345x180x15
16	1/1	02	Frente de gaveta Frente de cajón Front of drawer	396x149x15
17	1/1	04	Lado de Gaveta Lado del cajón Drawer Side	400x90x15
18=14	1/1	02	Fundo de gaveta Fondo de cajón Bottom of drawer	411x326x3
19	1/1	02	Ripa de trás Malla detrás Rear lath	345x90x15
20	1/1	01	Travessa Sustentação Travessa Ayuda Support Travessa	1190x50x15

HENN

Ind. e Com. de Móveis Henn
Mondai - SC - Brasil

+55 49 3674.3500

@moveishenn
www.henn.com.br

INSTRUÇÕES DE MONTAGEM

INSTRUCCIONES DE MONTAJE
ASSEMBLY INSTRUCTIONS

Balcão Pia 02 Portas 03 Gavetas Belize
Fregadero 02 Puertas 03 Cajones Belize | Counter Sink 02 Doors 03 Drawers Belize
C508-131 Cinza

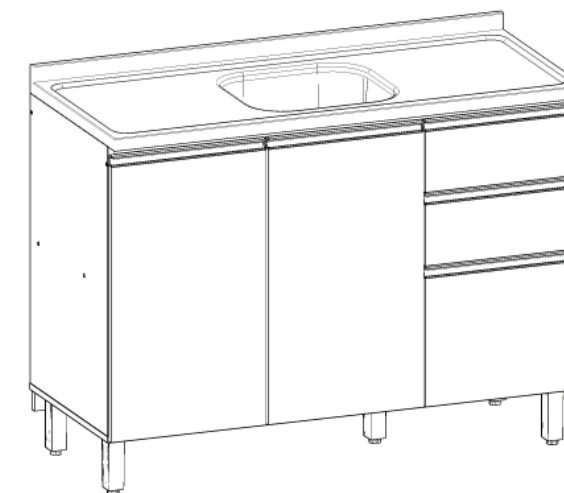
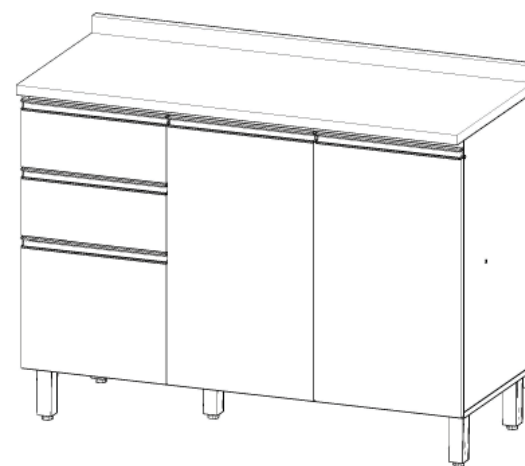
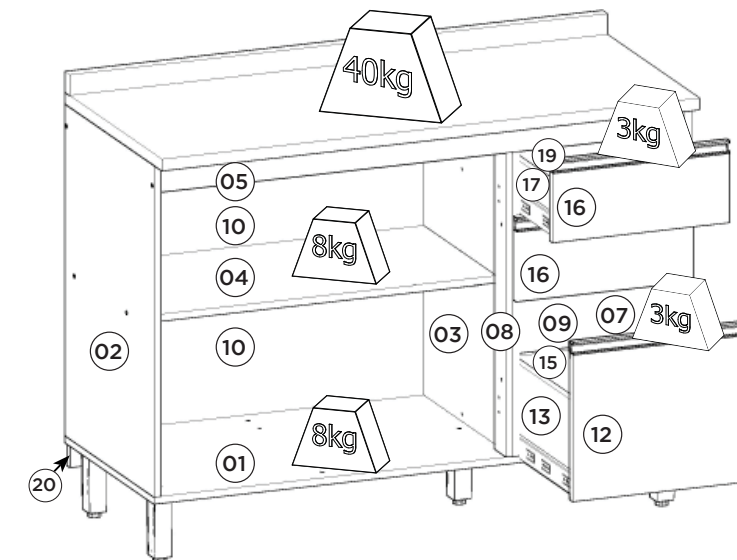
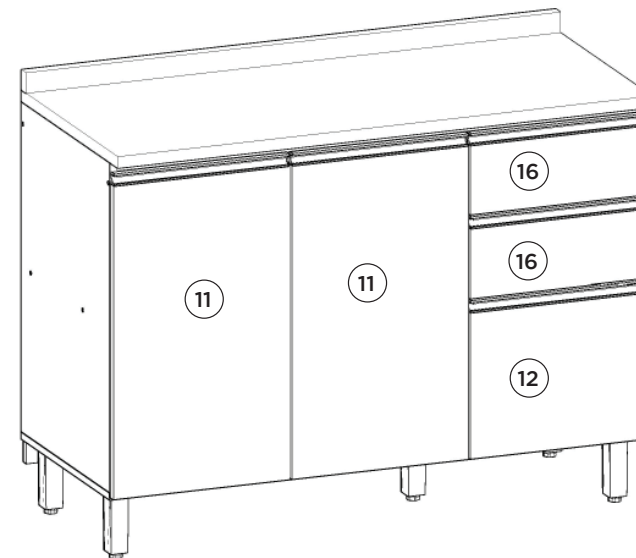

Pesos máximos recomendados com carga distribuída
Peso máximo recomendado con la carga distribuída
Recommended maximum weights with evenly distributed.

Ferragens | Herrajes | Hardware

A Parafuso 7,0x40mm CHT. Tornillo 7,0x40mm CHT. Screw 7,0x40mm CHT.	B Parafuso 5,0x50mm FLA. Tornillo 5,0x50mm FLA. Screw 5,0x50mm FLA.	C Parafuso 4,5x50mm CHT. Tornillo 4,5x50mm CHT. Screw 4,5x50mm CHT.	D Parafuso 4,0x25mm CHT. Tornillo 4,0x25mm CHT. Screw 4,0x25mm CHT.	E Parafuso 3,5x40mm CHT. Tornillo 3,5x40mm CHT. Screw 3,5x40mm CHT.	F Parafuso 3,5x14mm FLA. Tornillo 3,5x14mm FLA. Screw 3,5x14mm FLA.
G Parafuso 3,5x12mm CHT. Tornillo 3,5x12mm CHT. Screw 3,5x12mm CHT.	H Parafuso 3,0x30mm CHT. Tornillo 3,0x30mm CHT. Screw 3,0x30mm CHT.	I Prego 10x10mm Clavo 10x10mm Nail 10x10mm	J Fixador de fundos Fijador de fondos Bottom fixer	K Cavilha 8x25mm Cinta 8x25mm Dowel 8x25mm	L Parafuso minifix Tornillo minifix Minifix bolt
M Tambor minifix Tambor minifix Minifix drum	N Pé 145mm x 42mm Pie 145mm x 42mm Foot 145mm x 42mm	O Cantoneira plástica Cantenera plástica Plastic angle brackets	P Calço Removível Calzado extraíble Removable Shim	Q Dobradilha SlideOn Baixa Amortecedor 35mm Bisagra SlideOn Baja Amortiguador 35mm Low SlideOn Hinge 35mm Shock Absorber	R Puxador MOV4083 - 396mm Tirador MOV4083 - 396mm MOV4083 - 396mm Handle
S Corrediça telescópica Diapositivas telescópicas Telescopic slides	T Parafuso União 30mm Tornillo Unión 30mm Union Screw 30mm	U Bucha plástica 8mm Bucha de plástico 8mm 8mm plastic bushing	V Divisor talheres 398x313mm Divisor cubiertos 398x313mm Cutlery divider 398x313mm	W Sachê de cola Bolsa de pegamento Glue bag	X Giz de correção Tiza de corrección Chalk of correction
Y Suporte de fixação Soporte de fijación Mounting bracket	Z Proteção para cantoneira Ángulo de protección Protection angle	AA Adesivo tapa parafuso 17mm Adhesivo tapón de tornillo 17mm Bolt cover adhesive 17mm	AB Adesivo tapa parafuso 10mm Adhesivo tapón de tornillo 10mm Bolt cover adhesive 10mm	AC Etiqueta resinada Henn Etiqueta resinada Henn Henn resin label	

Requisitos para montagem
Requisitor para la montaje
Assembly Requirements

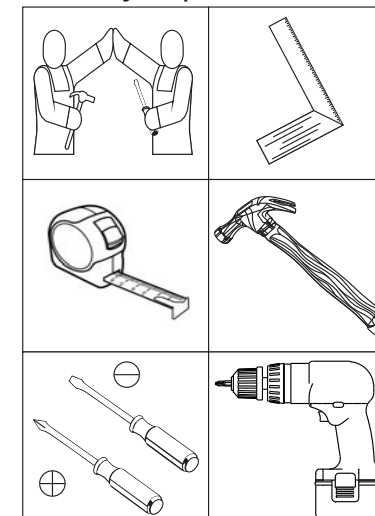

Imagens meramente ilustrativas
Imágenes meramente ilustrativas
Images for illustration only

RECOMENDAÇÃO

Para fixar o móvel na parede usar o suporte de fixação (Y), o parafuso 3,5x14mm FLA (F), a Bucha 8mm (U) e o parafuso 5,0x50mm FLA (B).

RECOMENDACIÓN

Para conectar el móvil a la pared con el soporte (Y), tornillo 3,5 x14mm FLA (F), el casquillo de 8 mm (U) y el 5,0 x50mm tornillo FLA (B).

RECOMMENDATION

To fix the furniture to the wall use the mounting bracket (Y), the 3.5x14mm FLA (F) screw, the 8mm bushing (U) and the 5.0x50mm FLA (B) screw.

AVISO

Para limpeza de seu móvel, use uma flanela seca ou umedecida, e não utilize produtos químicos que possam danificar seu produto.

SISTEMA DE MONTAGEM

O sistema de montagem dos produtos, funciona de acordo com a ordem crescente dos números indicados no desenho. Ex: 01, 02, 03, 04... até a conclusão da montagem.

ADVERTENCIA

Para limpieza de su móvil, use una flanela seca o húmeda, y no utilice productos químicos que puedan dañar su producto.

SISTEMA DE MONTAJE

El sistema de montaje de los productos funciona de acuerdo con el orden creciente de los números indicados en el dibujo. Ej.: 01, 02, 03, 04... hasta la conclusión del montaje.

NOTICE

To clean your furniture, use a dry or wet cloth, and do not use chemicals that may damage your product.

ASSEMBLY SYSTEM

The products' assembly system works according to the increasing order of the indicated numbers. For example: 01, 02, 03, 04 ... to the end of the assembly.

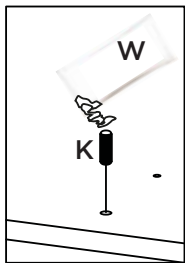
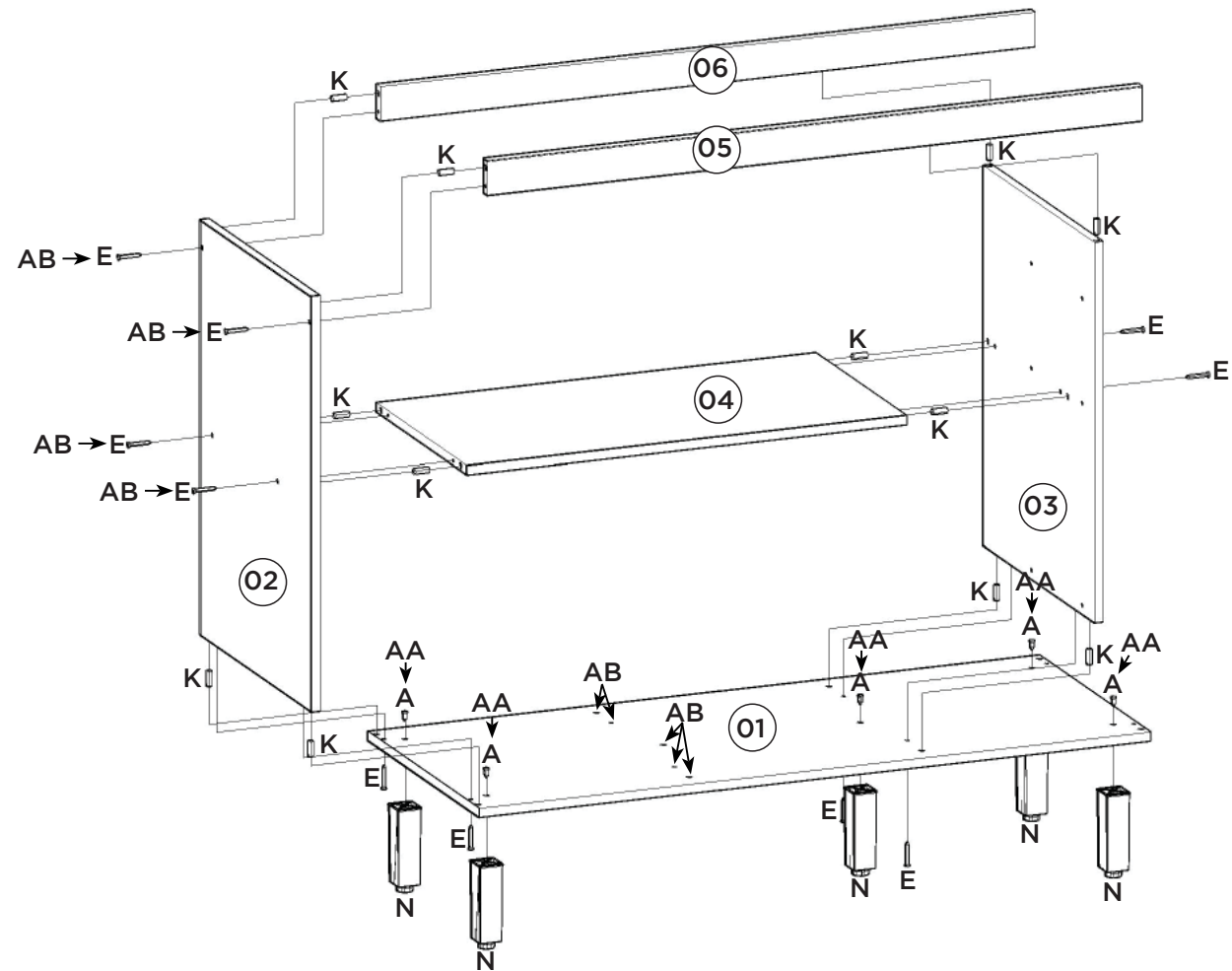

Utilizar o sachê de cola (W) em todas as cavilhas (K) do produto.

Con el pegamento sobre (W) en todos los pernos (K) producto.

Use the glue sachet (W) on all the pegs (K) of the product.

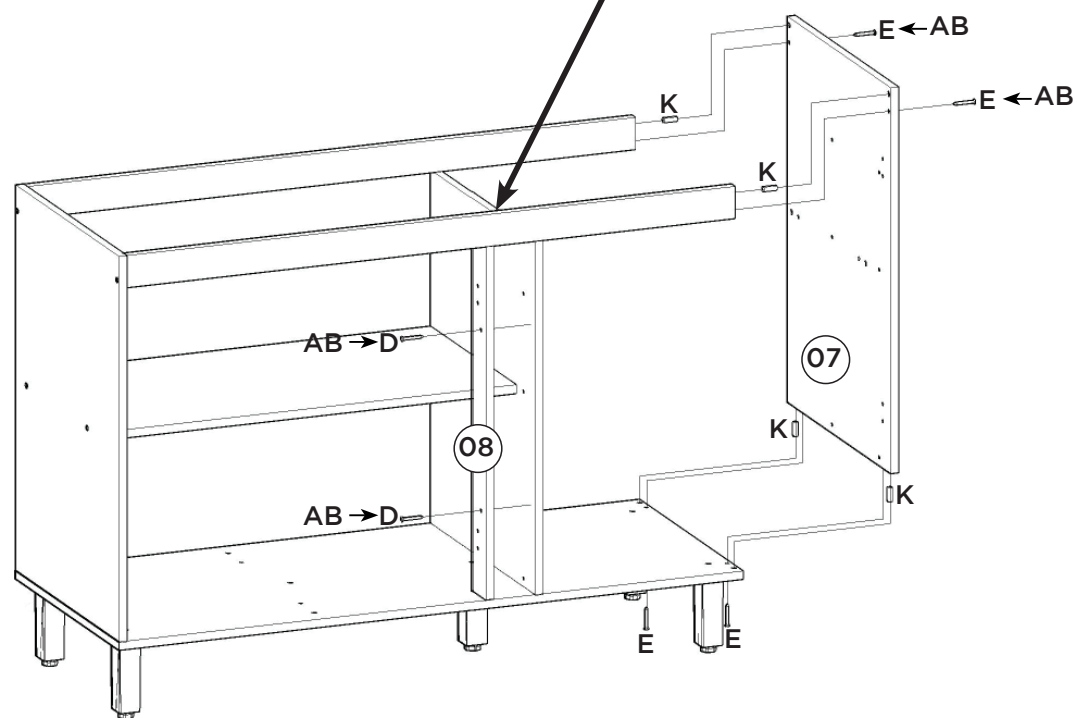
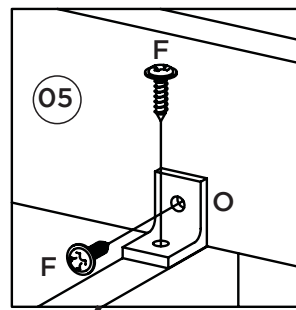

A pilastra da porta (08) deve estar alinhada com a divisão (03).

El pilar de la puerta (08) debe estar alineada con la división (03).

The door pillar (08) must be aligned with the partition (03).

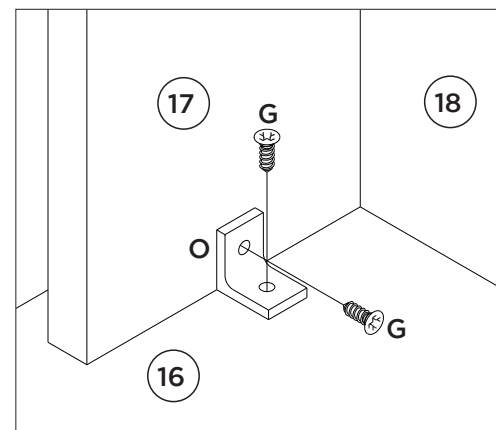
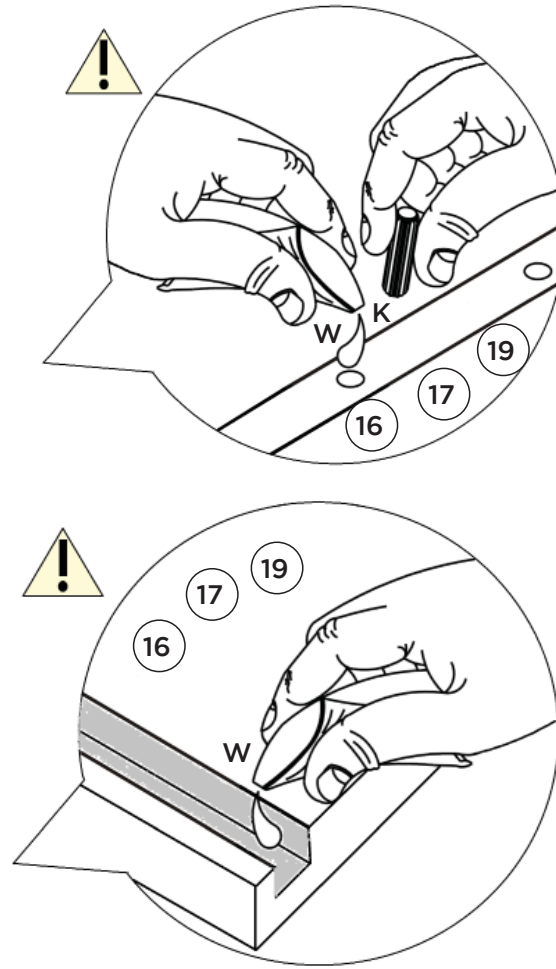
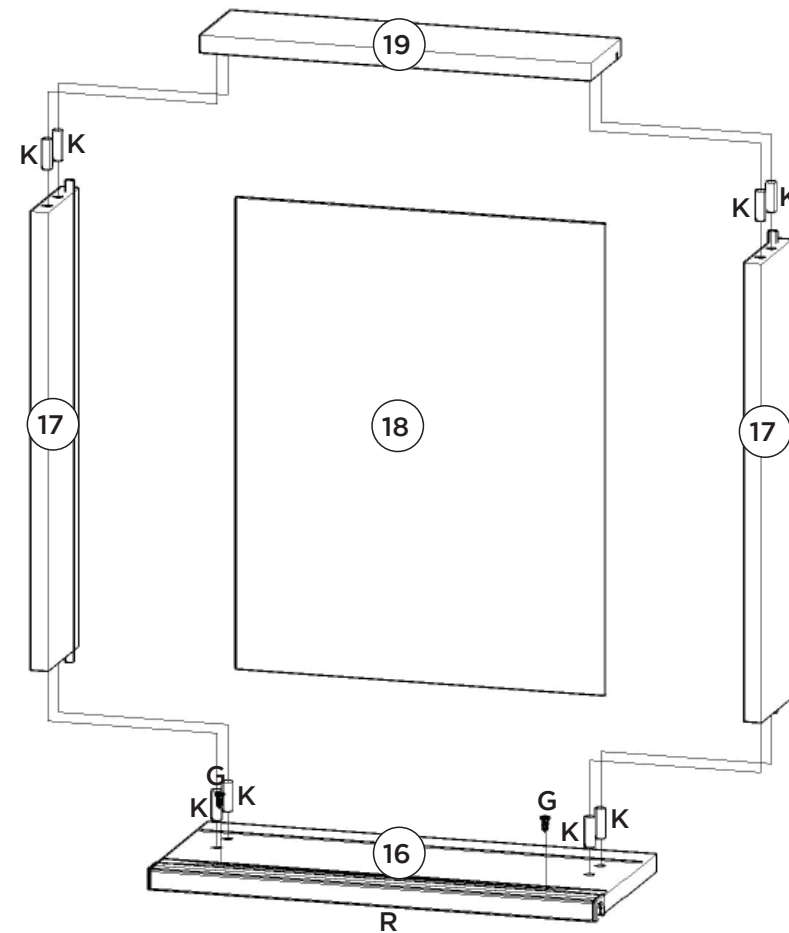

A corrediça (S) deverá ser alinhada com a parte de baixo do lado de gaveta (17).

La carcasa (S) será alineada con la parte de por el lado del cajón (17).

The slide (S) should be aligned with the underside of the drawer side (17).

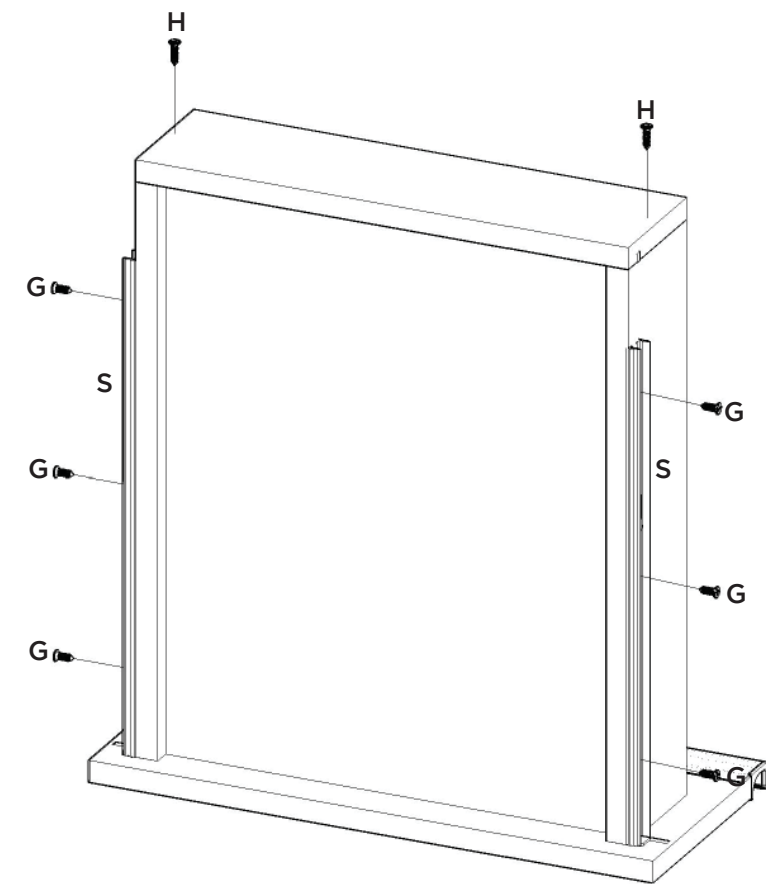

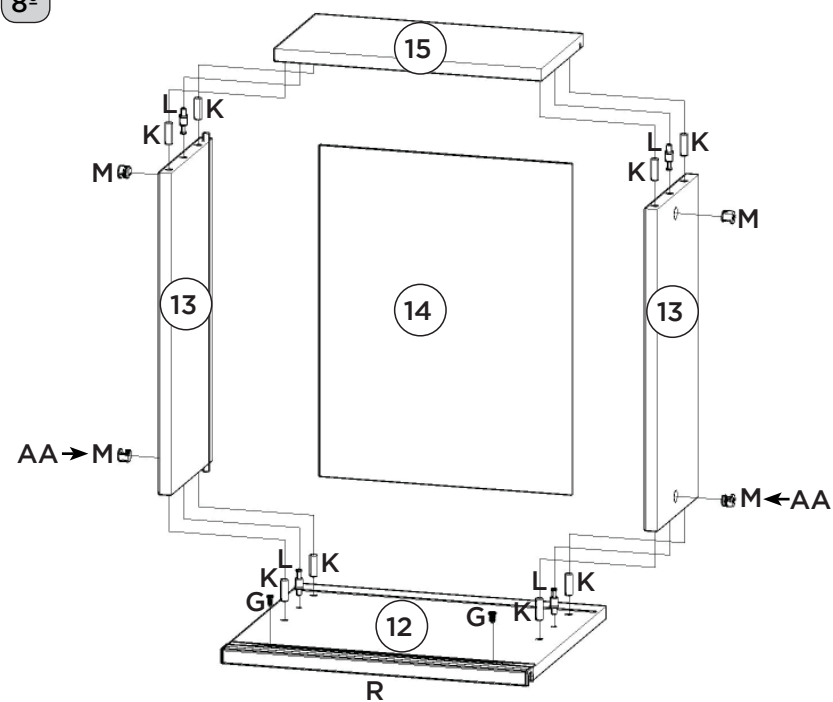
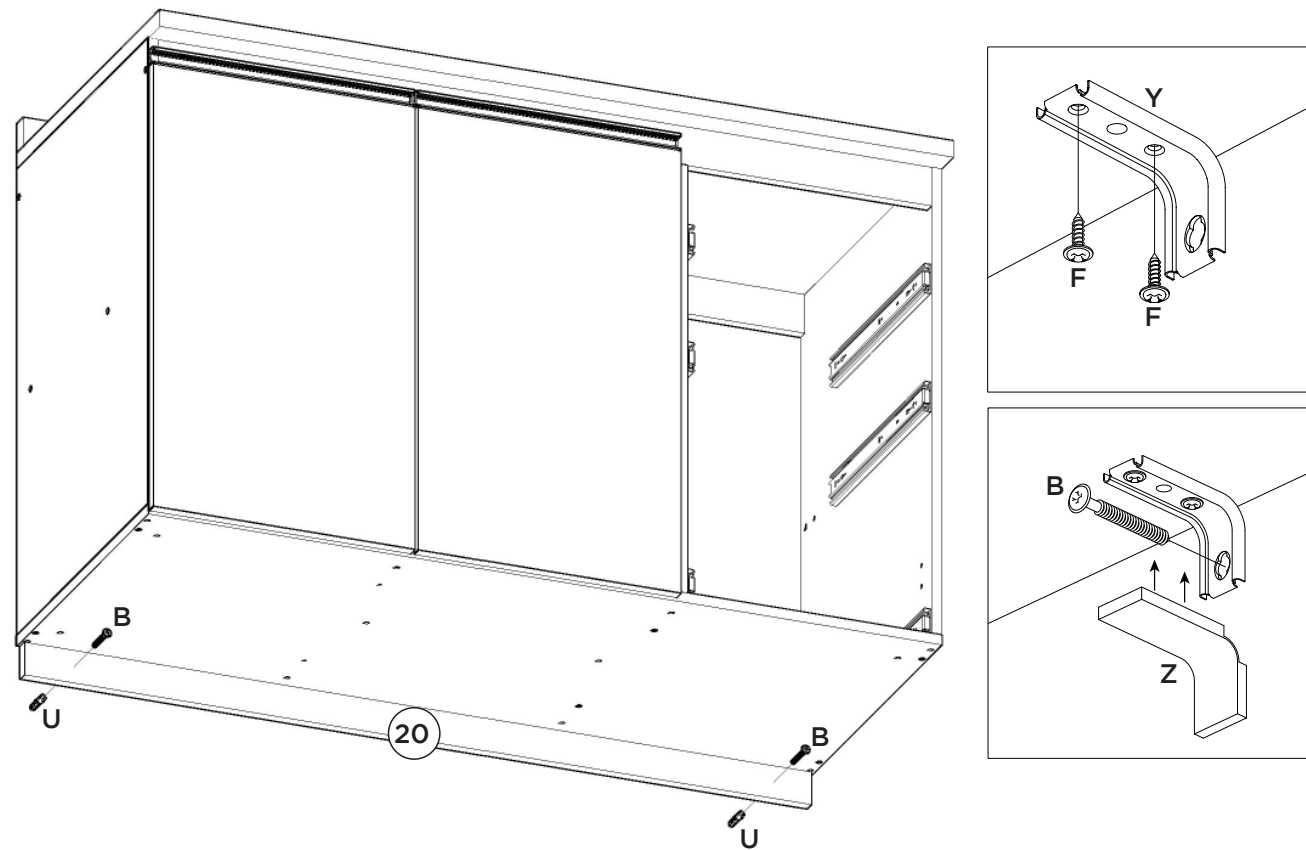
Parede
pared
Wall

A corredeira (S) deverá ser alinhada com a parte de baixo do lado de gaveta (13).

La carcasa (S) será alineada con la parte de por el lado del cajón (13).

The slide (S) should be aligned with the underside of the drawer side (13).

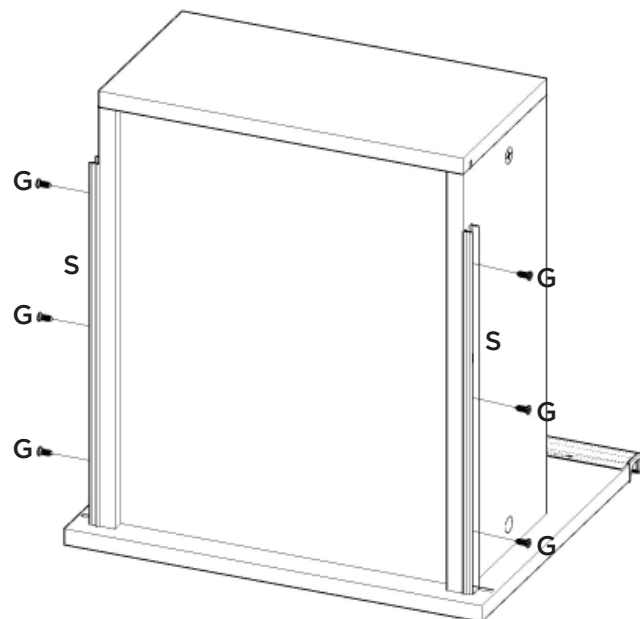

Esse tampo é opcional e é vendido separadamente (C905-33).

Esta vez es opcional y se vende por separado (C905-33).

This top is optional and is sold separately (C905-33).

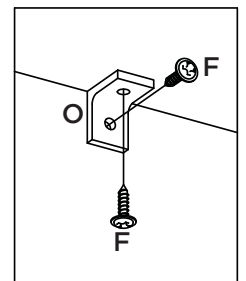
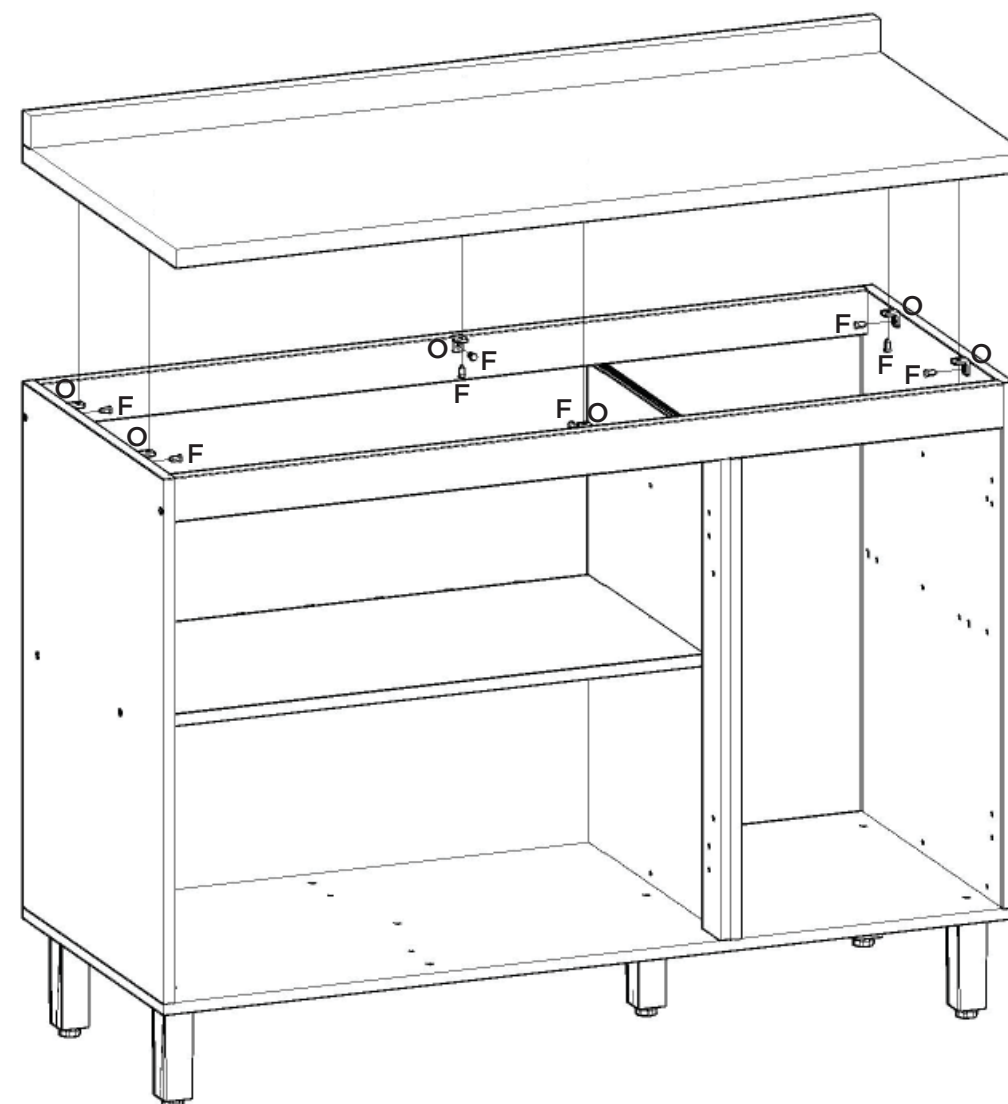
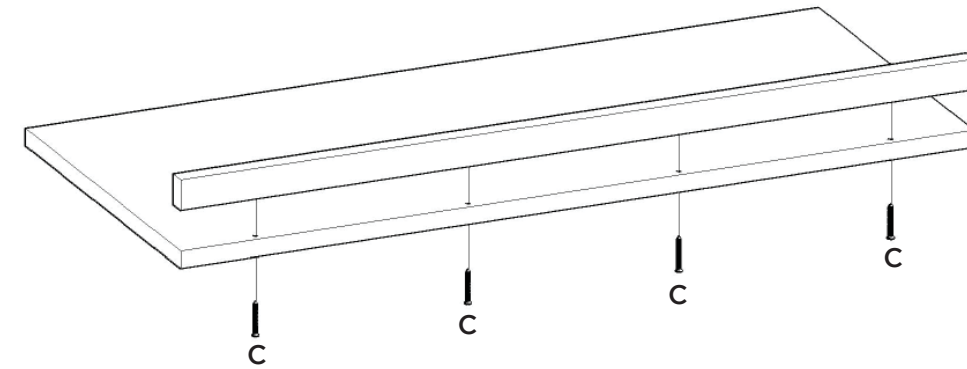

Caso o móvel seja montado com a opção do tampo, fixar o mesmo com 06 cantoneiras (O) e os parafusos 3,5x14mm (F).

Si se monta el auricular con la opción de la cubierta, fijarlo con Los ángulos 06 (O) y 3,5 x14mm tornillos (F).

If the furniture is to be installed with the top cover option, fix it with 06 (O) and 3.5x14mm screws (F).

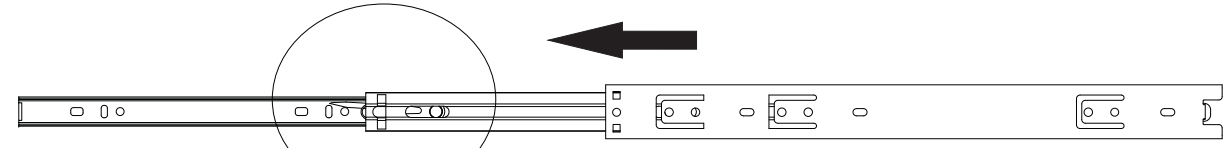
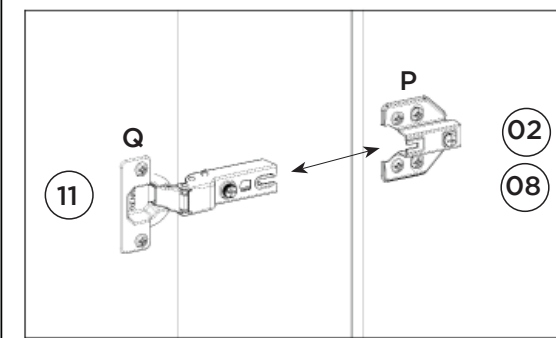
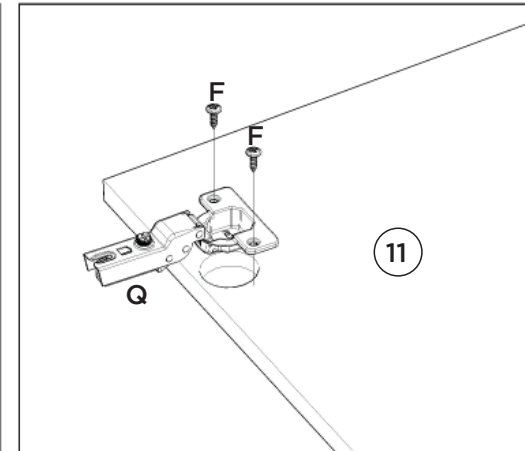
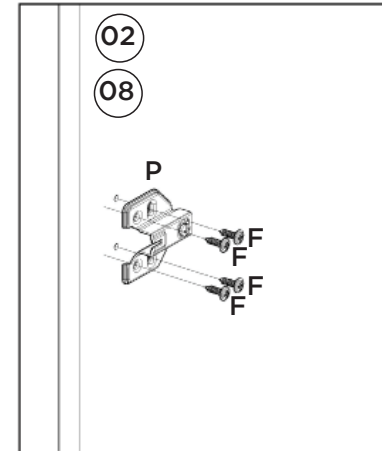
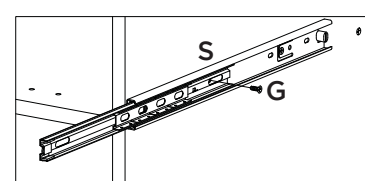
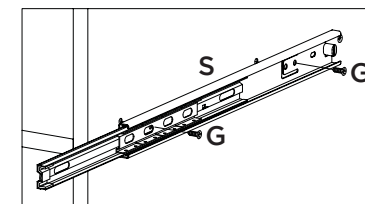
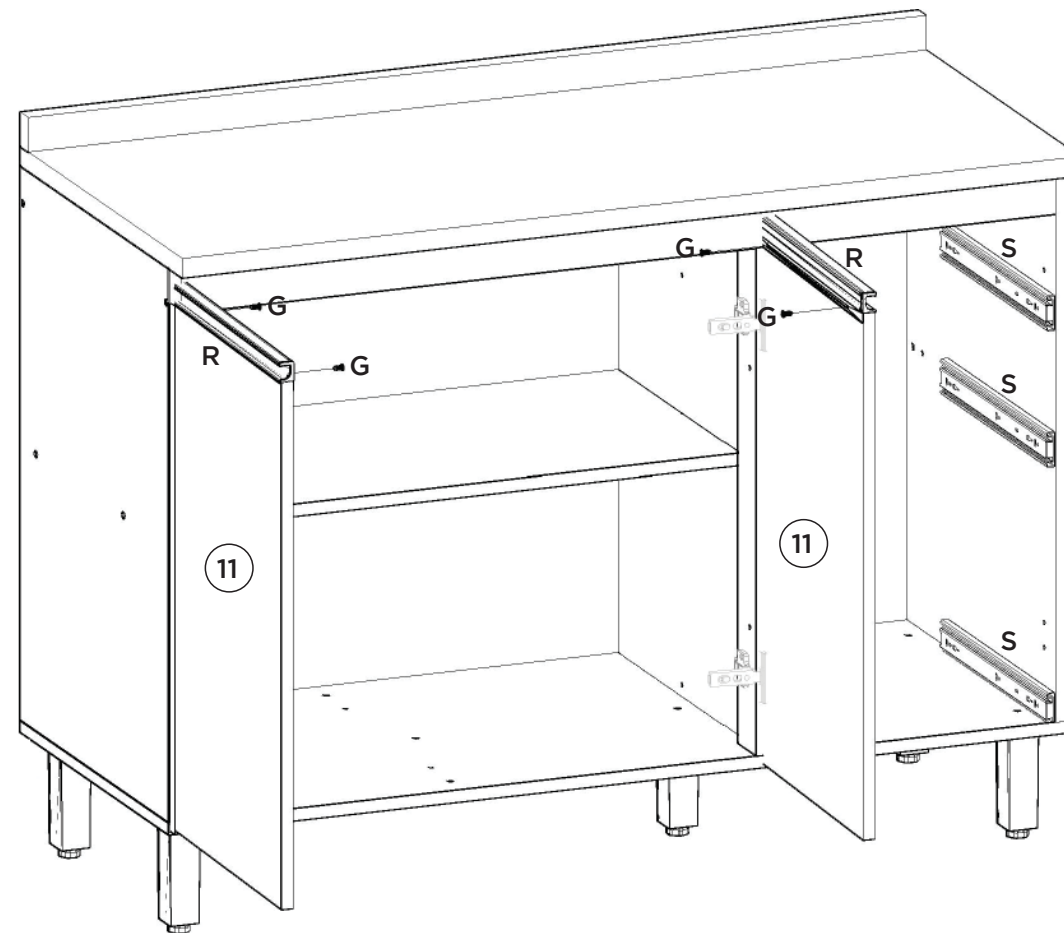
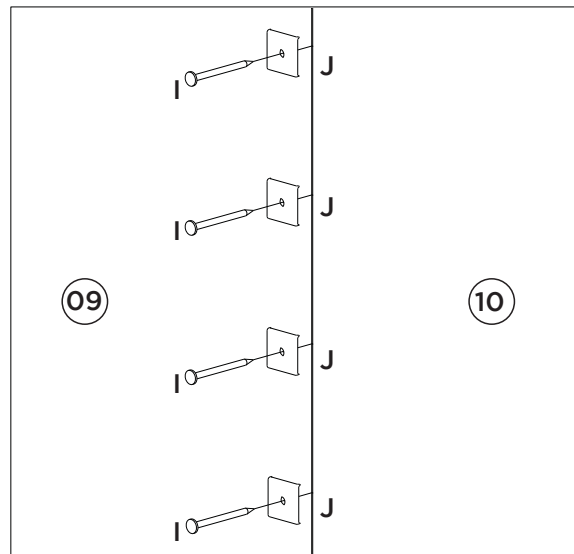
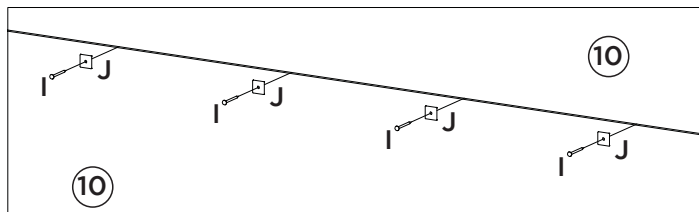
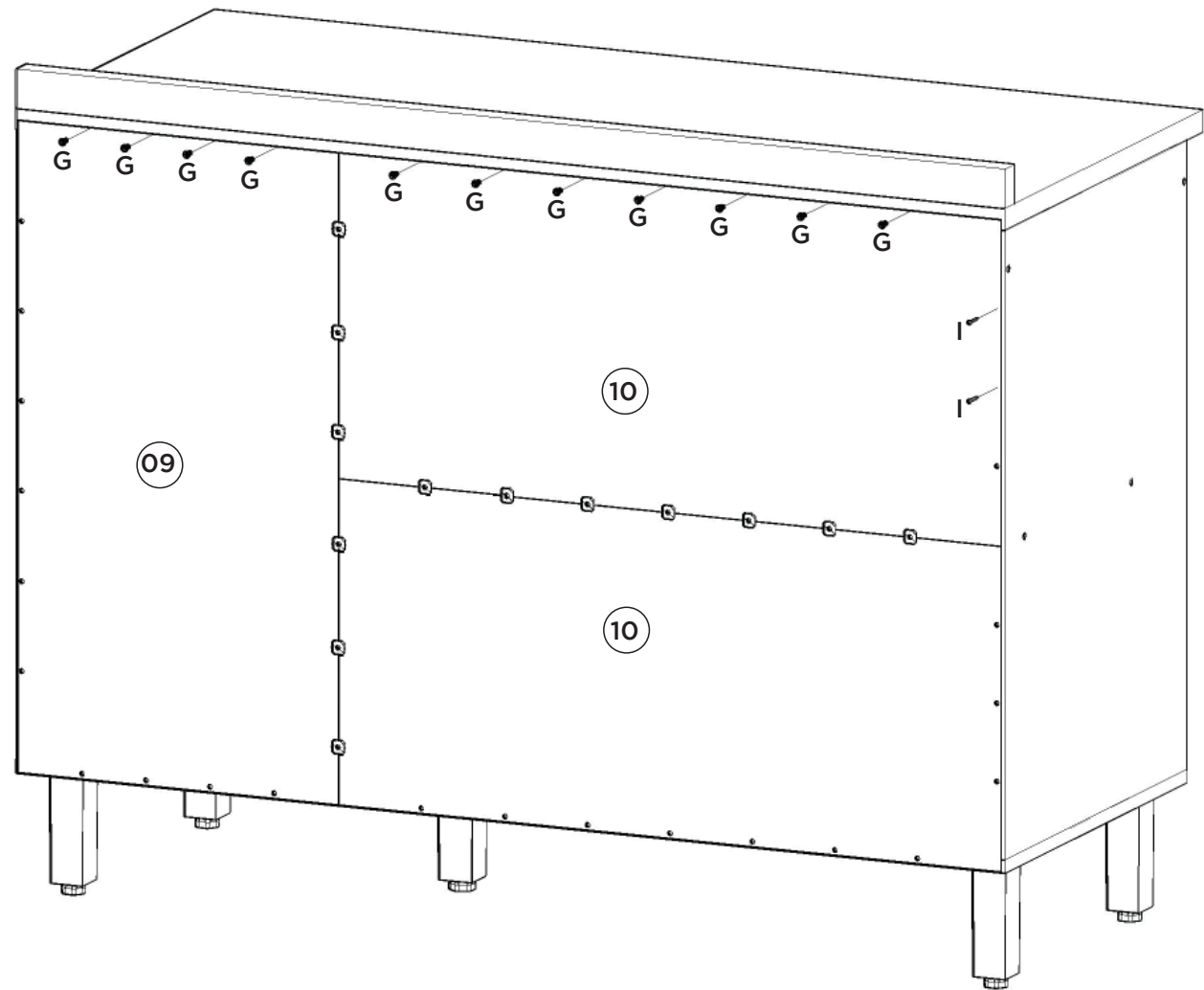

Para a desmontagem da correia siga a instrução ao lado.

Para el desmontaje seguimiento de diapositivas la instrucción siguiente a.

For the dismount of the sliding onem follows the instruction aside.

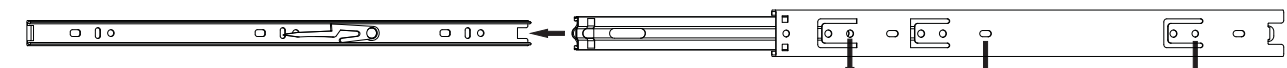
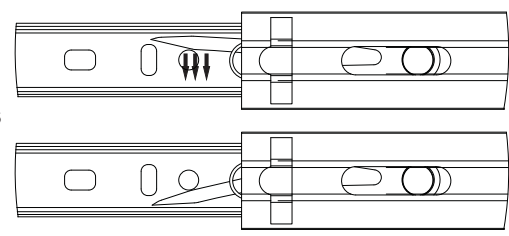

Fixar as correias nessas furações
Fijar las diapositivas de estos agujeros
Fix slides in these drillings

HENNInd. e Com. de Móveis Henn
Mondai - SC - Brasil

☎+55 49 3674.3500

📧@moveishenn
www.henn.com.br**INSTRUÇÕES DE MONTAGEM****INSTRUCCIONES DE MONTAJE
ASSEMBLY INSTRUCTIONS****BALÇÃO 2 PORTAS 800MM BELIZE | BALCÓN 2 PUERTAS 800MM BELIZE |
BALCONY 2 DOORS 800MM BELIZE**

Referência/Cor

☐ C509-131 - Cinza

Requisitos para montagem

Requisitor para la montaje

Assembly Requirements

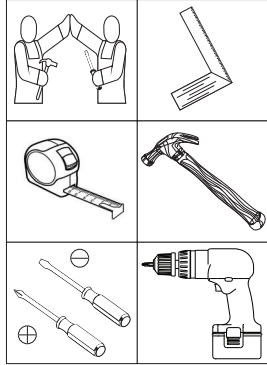
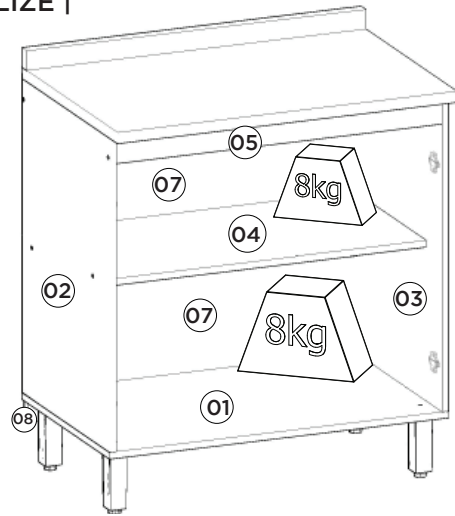
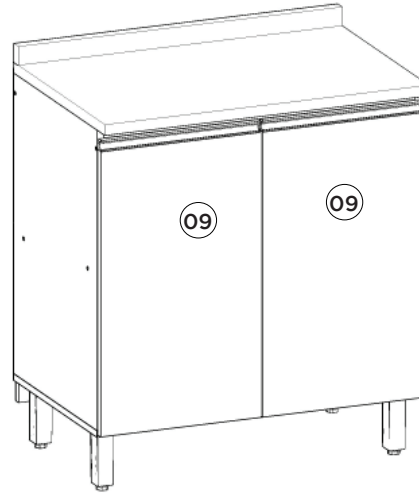
Imagens meramente ilustrativas
Imágenes meramente ilustrativas
Images for illustration only**Pesos máximos recomendados com carga distribuída
Peso máximo recomendado con la carga distribuida
Recommended maximum weights with evenly distributed.****AVISO**

Para limpeza de seu móvel, use uma flanela seca ou umedecida, e não utilize produtos químicos que possam danificar seu produto.

SISTEMA DE MONTAGEM

O sistema de montagem dos produtos, funciona de acordo com a ordem crescente dos números indicados no desenho. Ex: 01, 02, 03, 04... até a conclusão da montagem.

ADVERTENCIA

Para limpieza de su móvil, use una flanela seca o húmeda, y no utilice productos químicos que puedan dañar su producto.

SISTEMA DE MONTAJE

El sistema de montaje de los productos funciona de acuerdo con el orden creciente de los números indicados en el dibujo. Ej.: 01, 02, 03, 04... hasta la conclusión del montaje.

NOTICE

To clean your furniture, use a dry or wet cloth, and do not use chemicals that may damage your product.

ASSEMBLY SYSTEM

The products' assembly system works according to the increasing order of the indicated numbers. For example: 01, 02, 03, 04 ... to the end of the assembly.

Lista de Peças | Lista de piezas | List of parts

Item	Caixa Caja Box	Qtd Ctd Qty	Descrição Descripción Description	Medidas (mm) Dimensions (mm) Size (measurements) (mm)
01	1/1	01	Base Base Base	800x490x15
02	1/1	01	Lateral esquerda Lateral izquierda Left side	715x490x15
03	1/1	01	Lateral direita Lateral derecha Right side	715x490x15
04	1/1	01	Prateleira Estante Shelf	769x400x15
05	1/1	01	Travessa frontal Travesaño frontal Front crossbar	769x60x15
06	1/1	01	Travessa traseira Travesaño trasero Rear bumper	769x60x15
07	1/1	02	Fundo Fondo Bottom	793x363x3
08	1/1	01	Travessa Sustentação Placa de suporte Support Plate	790x50x15
09	1/1	02	Porta Puerta Door	680x396x15

Ferragens | Herrajes | Hardware

A Parafuso 7,0x40mm CHT. Tornillo 7,0x40mm CHT. Screw 7,0x40mm CHT.	B Parafuso 5,0x50mm FLA. Tornillo 5,0x50mm FLA. Screw 5,0x50mm FLA.	C Parafuso 4,5x50mm CHT. Tornillo 4,5x50mm CHT. Screw 4,5x50mm CHT.	D Parafuso 3,5x40mm CHT. Tornillo 3,5x40mm CHT. Screw 3,5x40mm CHT.	E Parafuso 3,5x14mm FLA. Tornillo 3,5x14mm FLA. Screw 3,5x14mm FLA.	F Parafuso 3,5x12mm CHT. Tornillo 3,5x12mm CHT. Screw 3,5x12mm CHT.	G Parafuso União 30mm Tornillo Unión 30mm Union Screw 30mm	H Cavilha 8x25mm Cinta 8x25mm Dowel 8x25mm
I Prego 10x10mm Clavo 10x10mm Nail 10x10mm	J Fixador de fundos Fijador de fondos Bottom fixer	K Cantoneira plástica Cantонера plástica Plastic angle brackets	L Pé 145mm x 42mm Pie 145mm x 42mm Foot 145mm x 42mm	M Puxador ALX179 - 396mm Tirador ALX179 - 396mm ALX179 - 396mm Handle	N Calço Removível Calzado extraíble Removable Shim	O Dobradica SlideOn Baixa Amort. 35mm Bisagra SlideOn Abajo Amort. 35mm Hinge SlideOn Low damper 35mm	P Adesivo tapa parafuso 17mm Adhesivo tapón de tornillo 17mm Bolt cover adhesive 17mm
Q Buchas plásticas 8mm Buchas de plástico 8mm 8mm plastic bushing	R Suporte de fixação Soporte de fijación Mounting bracket	S Proteção para cantoneira Ángulo de protección Protection angle	T Giz de correção Tiza de corrección Chalk of correction	U Sachê de cola Bolsa de pegamento Glue bag	V Adesivo tapa parafuso 10mm Adhesivo tapón de tornillo 10mm Bolt cover adhesive 10mm	W Batente PVC para Porta Parada de PVC para Puerta PVC Door Stop	

O parafuso (G) deve ser usada somente quando este módulo for acoplado a outro módulo componível Henn.

El tornillo (G) se debe utilizar sólo cuando el módulo está conectado a otro módulo componible Henn.

The screw (G) should be used only when this module is attached to another Henn modular module.

RECOMENDAÇÃO

Para fixar o móvel na parede usar o suporte de fixação (R), o parafuso 3,5x14mm FLA (E), a Bucha 8mm (Q) e o parafuso 5,0x50mm FLA (B).

RECOMENDACIÓN

Para conectar el móvil a la pared con el soporte (R), tornillo 3,5 x14mm FLA (E), el casquillo de 8 mm (Q) y el 5,0 x50mm tornillo FLA (B).

RECOMMENDATION

To fix the furniture to the wall use the mounting bracket (R), the 3.5x14mm FLA (E) screw, the 8mm bushing (Q) and the 5.0x50mm FLA (B).

1º

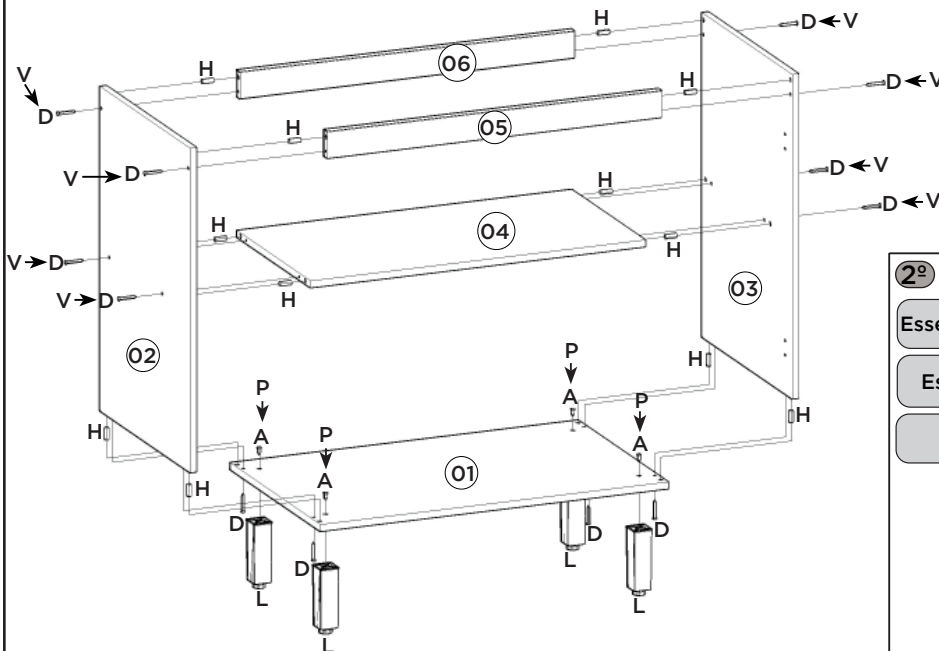

Utilizar o sachê de cola (U) em todas as cavilhas (H) do produto.

Con el pegamento sobre (U) en todos los pernos (H) producto.

Use the glue sachet (U) on all the pegs (H) of the product.

2º

Esse tampo é opcional e é vendido separadamente (C904-33).

Esta vez es opcional y se vende por separado (C904-33).

This top is optional and is sold separately (C904-33).

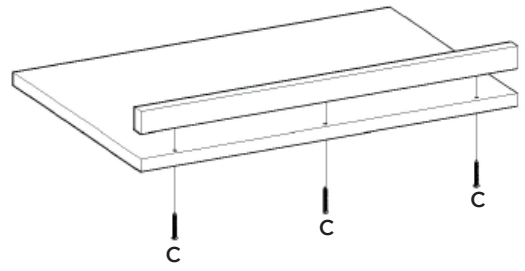

3º

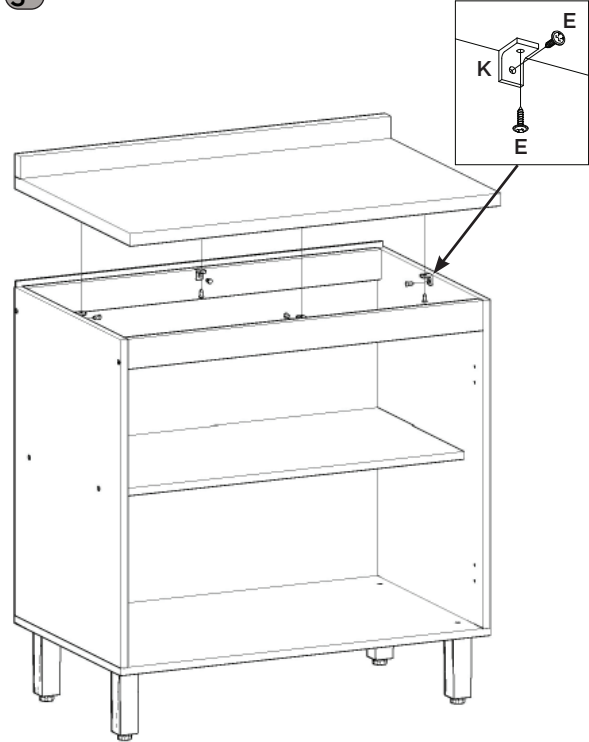

4º

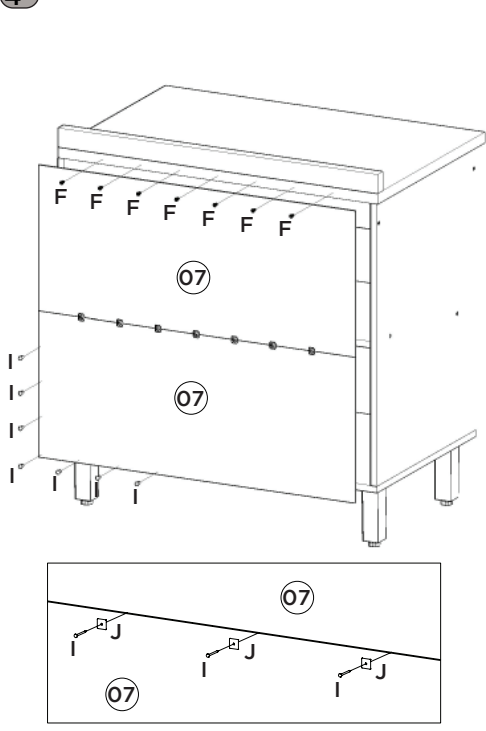

5º

Opcão Suspensa

Opción suspendida

Suspended option

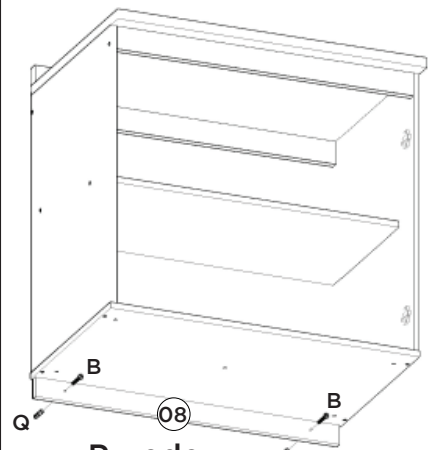

Parede

Pared

Wall

6º

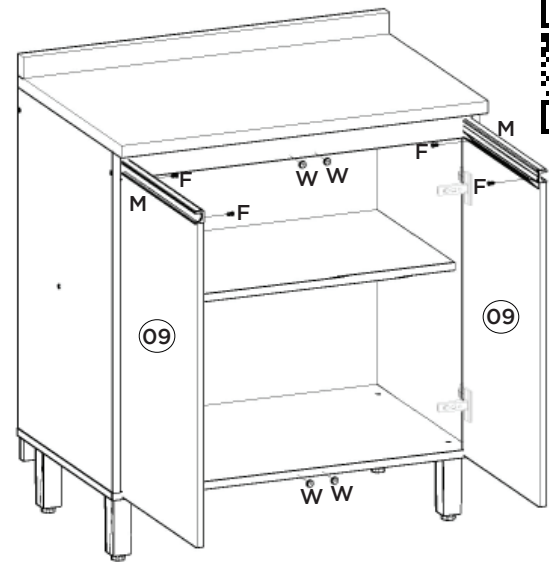

Video: Instalar e regular Dobradiças

Video: Instale y ajuste las bisagras

Video: Install and adjust hinges

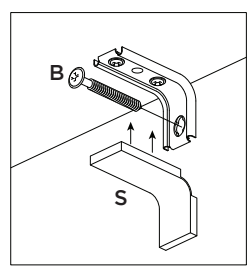
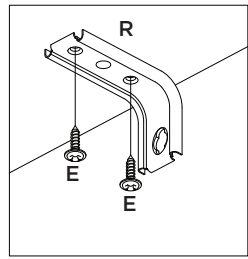
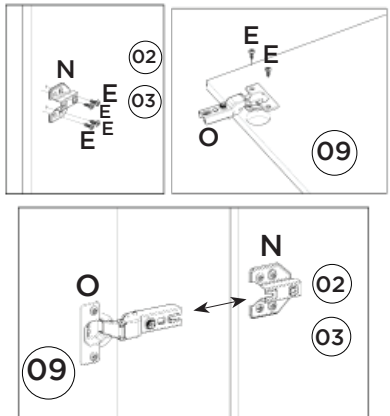

HENNInd. e Com. de Móveis Henn
Mondai - SC - Brasil

☎ +55 49 3674.3500

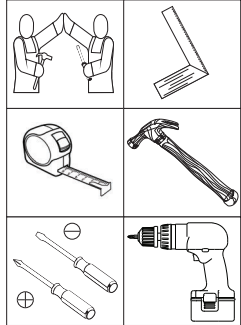
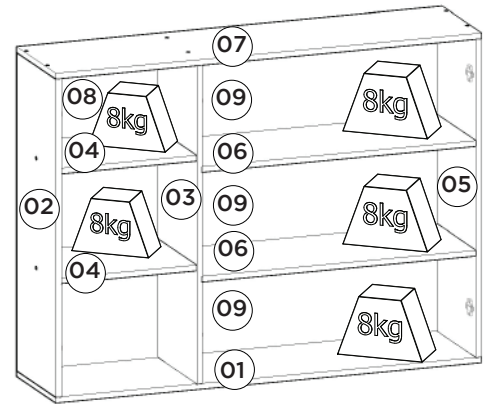
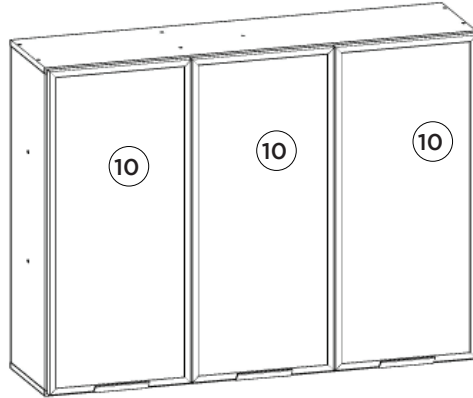
📱 @moveishenn
www.henn.com.br**INSTRUÇÕES DE MONTAGEM****INSTRUCCIONES DE MONTAJE**
ASSEMBLY INSTRUCTIONS**Aéreo 03 Portas de Vidro 1200mm Belize | Aereo 03 Puertas de vidrio 1200mm Belize |**
Aerial 03 GlassDoors 1200mm BelizeReferência/Cor
c C501-131 CinzaRequisitos para montagem
Requisitos para la montaje
Assembly RequirementsImagens meramente ilustrativas
Imágenes meramente ilustrativas
Images for illustration only**Pesos máximos recomendados com carga distribuída**
Peso máximo recomendado con la carga distribuida
Recommended maximum weight with distributed load.**Lista de Peças | Lista de piezas | List of parts**

Item	Caixa Caja Box	Qtd Ctd Qty	Descrição Descripción Description	Medidas (mm) Dimensions (mm) Size (measurements) (mm)
01	1/2	01	Base Base Base	1200x295x15
02	2/2	01	Lateral Esquerda Lateral Izquierda Right Left	870x295x15
03	2/2	01	Divisão División Division	870x295x15
04	2/2	02	Prateleira Menor Estante Pequeno Smaller Shelf	382x295x15
05	2/2	01	Lateral Direita Lateral Derecha Right Side	870x295x15
06	2/2	02	Prateleira Estante Shelf	772x295x15
07	1/2	01	Tampo Tapa Top	1200x295x15
08	1/2	01	Fundo Lateral Fondo Lateral Lateral Background	894x401x3
09	2/2	03	Fundo Fondo Bottom	790x298x3
10	1/2	03	Porta de Vidro Puerta de vidrio Glass door	888x394x20

Ferragens | Herrajes | Hardware

A 03x Parafuso 5,0x50mm FLA. Tornillo 5,0x50mm FLA. Screw 5,0x50mm FLA.	B 20x Parafuso 3,5x40mm CHT. Tornillo 3,5x40mm CHT. Screw 3,5x40mm CHT.	C 42x Parafuso 3,5x14mm FLA. Tornillo 3,5x14mm FLA. Screw 3,5x14mm FLA.	D 06x Parafuso 3,5x12mm CHT. Tornillo 3,5x12mm CHT. Screw 3,5x12mm CHT.	E 28x Cavilha 8x25mm Cinta 8x25mm Dowel 8x25mm	F 06x Calço Removível Calzado extraíble Removable Shim	G 06x Dobradica SlideOn Baja Amortecedor 35mm Bisagra SlideOn Baja Amortiguador 35mm Low SlideOn Hinge 35mm Shock Absorber
H 68x Prego 10x10mm Clavo 10x10mm Nail 10x10mm	I 03x Bucha plástica 8mm Bucha de plástico 8mm 8mm plastic bushing	J 03x Suporte de fixação Soporte de fijación Mounting bracket	K 03x Proteção para cantoneira Ángulo de protección Protection angle	L 04x Parafuso União 30mm Tornillo Unión 30mm Union Screw 30mm	M 03x Perfil Puxador 2015 - 150mm Perfil de Tirador 2015 - 150mm	N 02x Sachê de cola Bolsa de pegamento Glue bag
O 18x Adesivo tapan de tornillo 10mm Bolt cover adhesive 10mm	P 18x Fixador de fundos Fijador de fondos Bottom fixer	Q 01x Giz de correção Tiza de corrección Chalk of correction	R 01x Etiqueta resinada Henn Etiqueta resinada Henn Henn resin label			



O parafuso (L) deve ser usada somente quando este módulo for acoplado a outro módulo componível Henn.



El tornillo (L) se debe utilizar sólo cuando el módulo está conectado a otro módulo componible Henn.



The screw (L) should be used only when this module is attached to another Henn modular module.

RECOMENDAÇÃO

Para fixar o móvel na parede usar o suporte de fixação (J), o parafuso 3,5x14mm FLA (C), a Bucha 8mm (I) e o parafuso 5,0x50mm FLA (A).

RECOMENDACIÓN

Para conectar el móvil a la pared con el soporte (J), tornillo 3,5 x14mm FLA (C), el casquillo de 8 mm (I) y el 5,0 x50mm tornillo FLA (A).

RECOMMENDATION

To fix the furniture to the wall use the fixing bracket (J), the 3.5x14mm FLA (C) screw, the 8mm bushing (I) and the 5.0x50mm FLA screw (A).

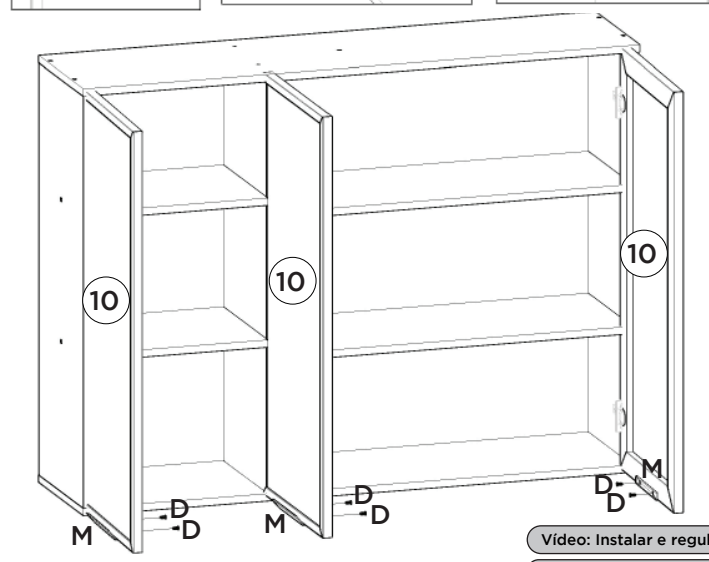
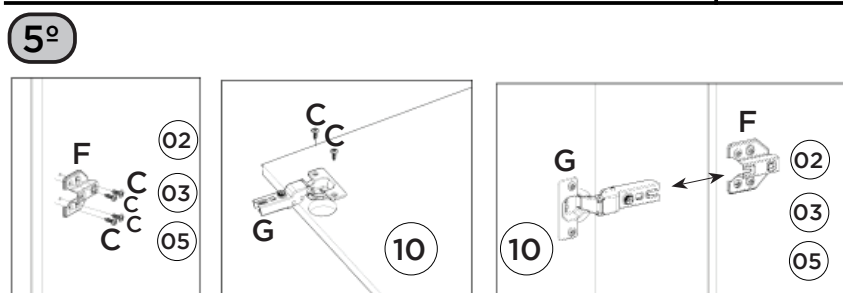
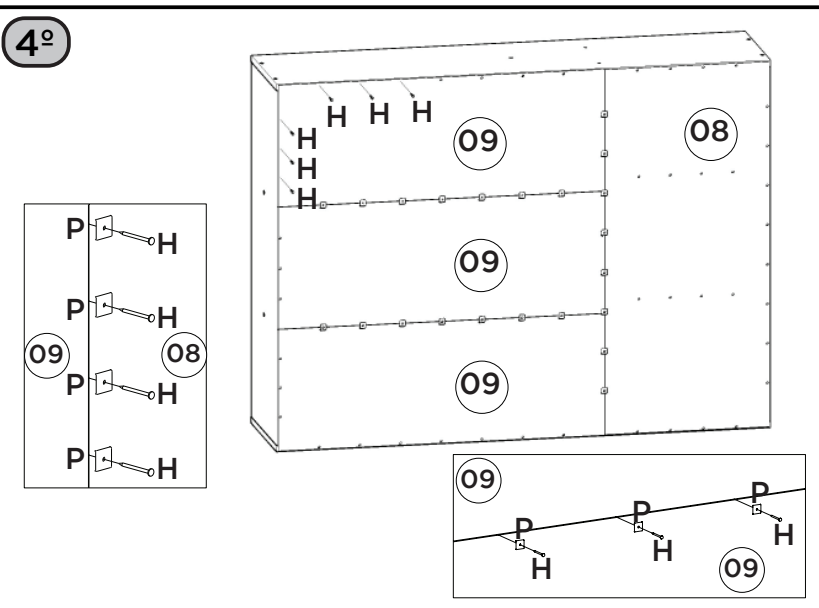
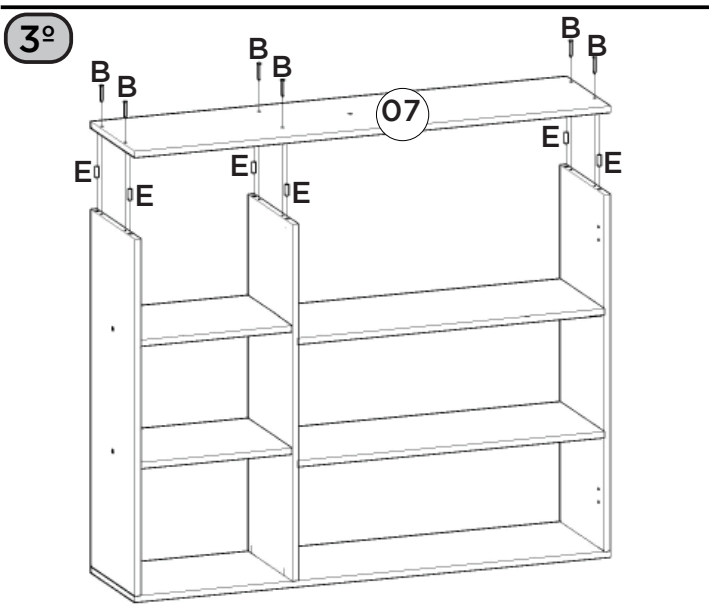
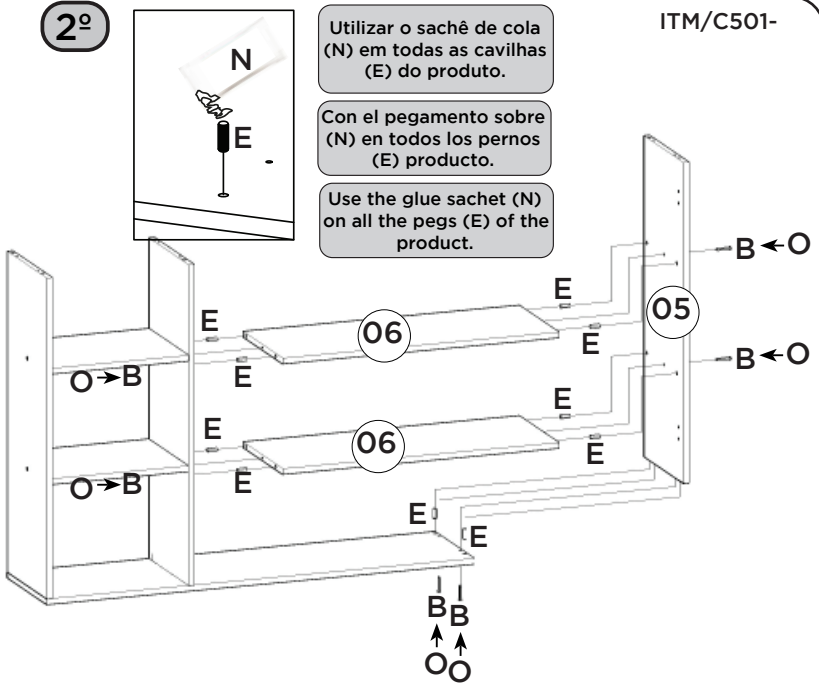
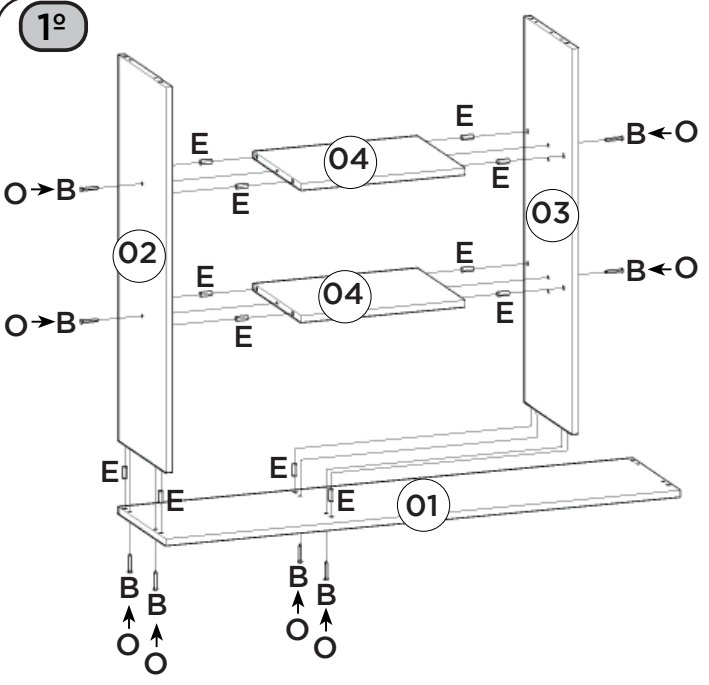

Video: Instalar e regular Dobradiças
 Video: Instale y ajuste las bisagras
 Video: Install and adjust hinges

AVISO
 Para limpeza de seu móvel, use uma flanela seca ou umedecida, e não utilize produtos químicos que possam danificar seu produto.

SISTEMA DE MONTAGEM
 O sistema de montagem dos produtos, funciona de acordo com a ordem crescente dos números indicados no desenho. Ex: 01, 02, 03, 04... até a conclusão da montagem.

ADVERTENCIA
 Para limpieza de su móvel, use una flanela seca o húmeda, y no utilice productos químicos que puedan dañar su producto.

SISTEMA DE MONTAJE
 El sistema de montaje de los productos funciona de acuerdo con el orden creciente de los números indicados en el dibujo. Ej.: 01, 02, 03, 04... hasta la conclusión del montaje.

NOTICE
 To clean your furniture, use a dry or wet cloth, and do not use chemicals that may damage your product.

ASSEMBLY SYSTEM
 The products' assembly system works according to the increasing order of the indicated numbers. For example: 01, 02, 03, 04 ... to the end of the assembly.

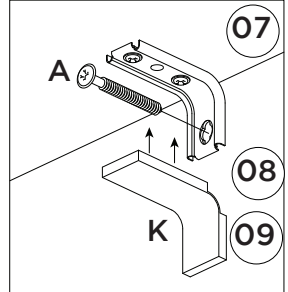
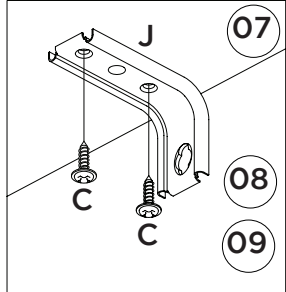

Aéreo 02 Portas 800mm Belize | Aéreo 02 Puertas 800mm Belize | Aerial 02 doors 800mm Belize

Referência/Cor
c C503-131 Cinza

Requisitos para montagem
Requisitos para la montaje
Assembly Requirements

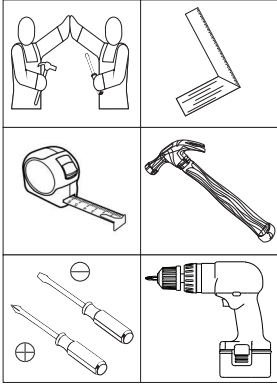

Imagens meramente ilustrativas
Imágenes meramente ilustrativas
Images for illustration only

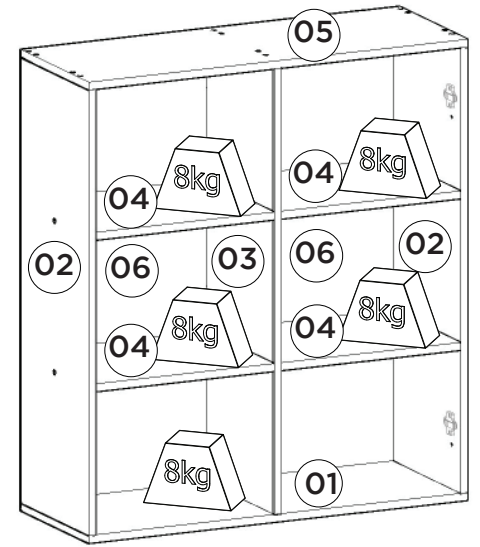
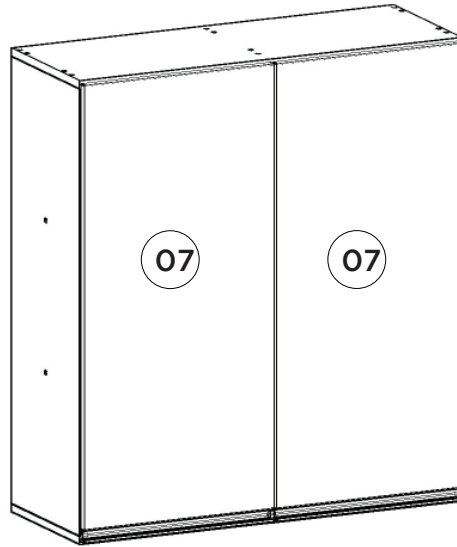

Pesos máximos recomendados com carga distribuída
Peso máximo recomendado con la carga distribuida
Recommended maximum weight with distributed load.

Lista de Peças | Lista de piezas | List of parts

Item	Caixa Caja Box	Qty Ctd Qty	Descrição Descripción Description	Medidas (mm) Dimensions (mm) Size (measurements) (mm)
01=05	1/1	01	Base Tampo Base y Top Base and Top	800x295x15
02	1/1	02	Lateral Direita Esquerda Lateral Derecha Izquierda Right Side Left	870x295x15
03	1/1	01	Divisão División Division	870x295x15
04	1/1	04	Prateleira Estante Shelf	377x295x15
05=01	1/1	01	Base Tampo Base y Top Base and Top	800x295x15
06	1/1	02	Fundo Fondo Bottom	894x395x3
07	1/1	02	Porta Puerta Door	865x396x15

Ferragens | Herrajes | Hardware

A 02x Parafuso 5,0x50mm FLA. Tornillo 5,0x50mm FLA. Screw 5.0x50mm FLA.	B 18x Parafuso 3,5x40mm CHT. Tornillo 3,5x40mm CHT. Screw 3.5x40mm CHT.	C 28x Parafuso 3,5x14mm FLA. Tornillo 3,5x14mm FLA. Screw 3.5x14mm FLA.	D 04x Parafuso 3,5x12mm CHT. Tornillo 3,5x12mm CHT. Screw 3.5x12mm CHT.	E 28x Cavilha 8x25mm Cinta 8x25mm Dowel 8x25mm	F 58x Prego 10x10mm Clavo 10x10mm Nail 10x10mm	G 08x Fixador de fundos Fijador de fondos Bottom fixer
H 04x Calço Removível Calzado extraíble Removable Shim	I 04x Dobradica SlideOn Baixa Amortecedor 35mm Bisagra SlideOn Baja Amortiguador 35mm Low SlideOn Hinge 35mm Shock Absorber	J 02x Puxador ALX179 - 396mm Tirador ALX179 - 396mm ALX179 - 396mm Handle	K 02x Bucha plástica 8mm Bucha de plástico 8mm 8mm plastic bushing	L 02x Suporte de fixação Soporte de fijación Mounting bracket	M 02x Proteção para cantoneira Ángulo de protección Protection angle	N 04x Parafuso União 30mm Tornillo Unión 30mm Union Screw 30mm
O 14x Adesivo tapa parafuso 10mm Adhesivo tapón de tornillo 10mm Bolt cover adhesive 10mm	P 01x Sachê de cola Bolsa de pegamento Glue bag	Q 02x Giz de correção Tiza de corrección Chalk of correction				

O parafuso (N) deve ser usada somente quando este módulo for acoplado a outro módulo componível Henn.

El tornillo (N) se debe utilizar sólo cuando el módulo está conectado a otro módulo componible Henn.

The screw (N) should be used only when this module is attached to another Henn modular module.

RECOMENDAÇÃO
Para fixar o móvel na parede usar o suporte de fixação (L), o parafuso 3,5x14mm FLA (C), a Bucha 8mm (K) e o parafuso 5,0x50mm FLA (A).

RECOMENDACIÓN
Para conectar el móvil a la pared con el soporte (L), tornillo 3,5 x14mm FLA (C), el casquillo de 8 mm (K) y el 5,0 x50mm tornillo FLA (A).

RECOMMENDATION
To fix the furniture to the wall use the fixing bracket (L), the 3.5x14mm FLA (C) screw, the 8mm bushing (K) and the 5.0x50mm FLA (A).

1º

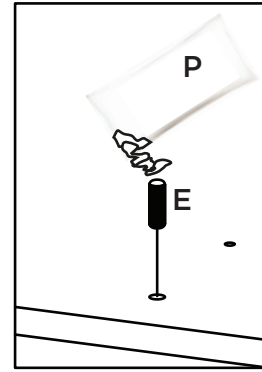
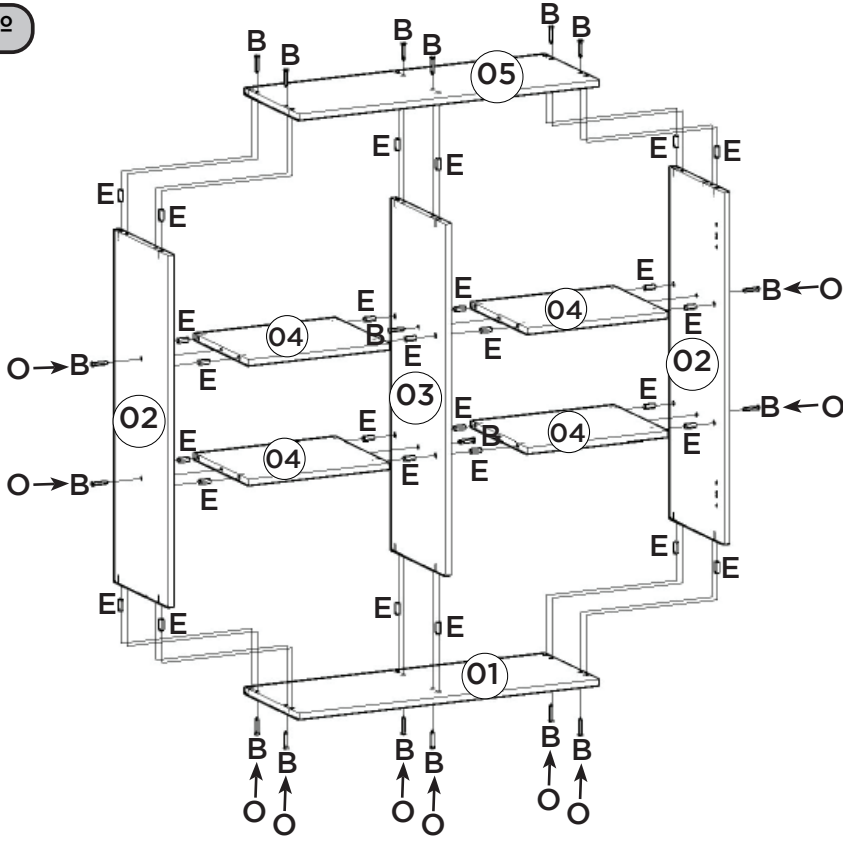

Utilizar o sachê de cola (P) em todas as cavilhas (E) do produto.

Con el pegamento sobre (P) en todos los pernos (E) producto.

Use the glue sachet (P) on all the pegs (E) of the product.

AVISO

Para limpeza de seu móvel, use uma flanela seca ou umedecida, e não utilize produtos químicos que possam danificar seu produto.

SISTEMA DE MONTAGEM

O sistema de montagem dos produtos, funciona de acordo com a ordem crescente dos números indicados no desenho. Ex: 01, 02, 03, 04... até a conclusão da montagem.

ADVERTENCIA

Para limpeza de su móvil, use una flanela seca o húmeda, y no utilice productos químicos que puedan dañar su producto.

SISTEMA DE MONTAJE

El sistema de montaje de los productos funciona de acuerdo con el orden creciente de los números indicados en el dibujo. Ej.: 01, 02, 03, 04... hasta la conclusión del montaje.

NOTICE

To clean your furniture, use a dry or wet cloth, and do not use chemicals that may damage your product.

ASSEMBLY SYSTEM

The products' assembly system works according to the increasing order of the indicated numbers. For example: 01, 02, 03, 04 ... to the end of the assembly.

2º

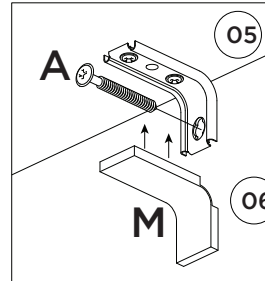
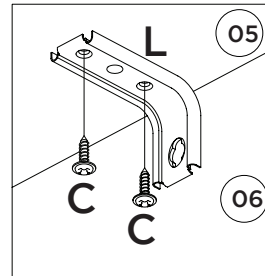
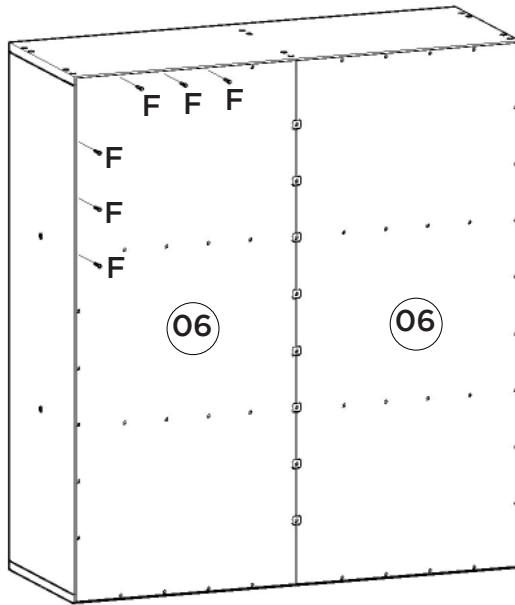
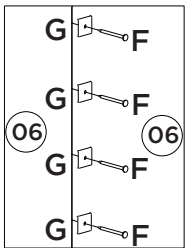

3º

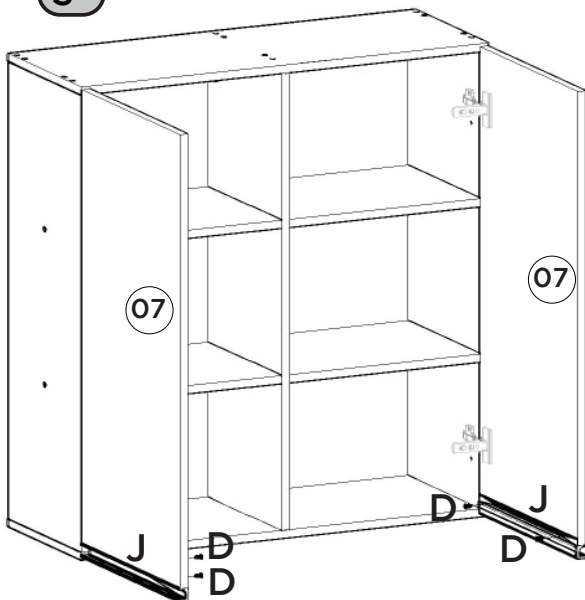

Video: Instalar e regular Dobradiças

Video: Instale y ajuste las bisagras

Video: Install and adjust hinges

