

REF.2025 **ESCRIVANINHA GIRATORIA CARINHO**
 ROTATING DESK / ESCRITORIO GIRATORIO

DETALHAMENTO EXTERNO
 OUTER DETAIL / DETALLES EXTERNOS

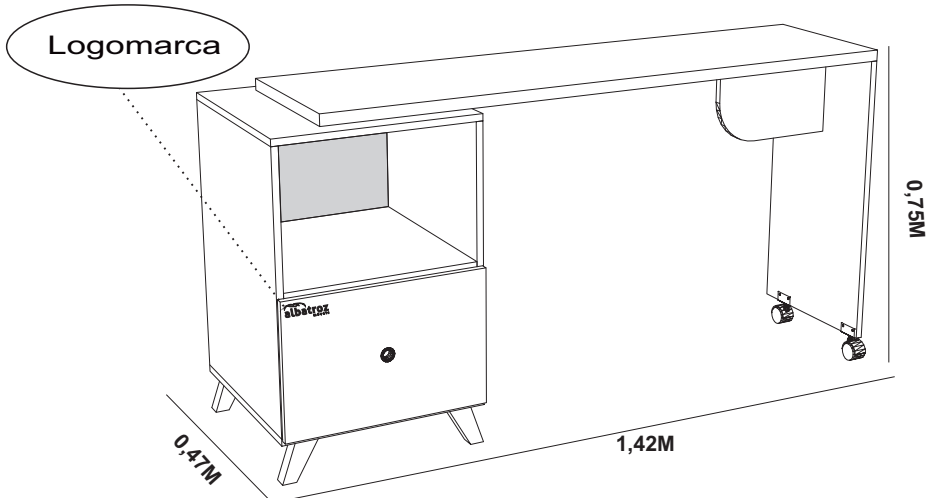

DETALHAMENTO INTERNO
 INSIDER DETAILS/DETALLES INTERNOS

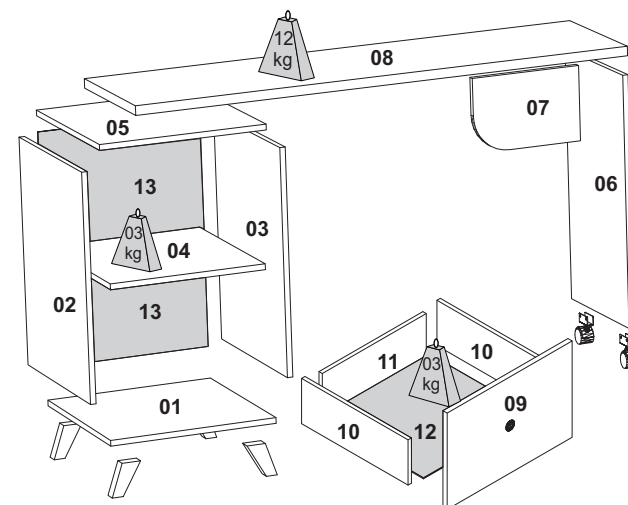

INSTRUÇÃO MONTAGEM PRODUTO
 ASSEMBLY INSTRUCTION / INSTRUCCIONES DE MONTAJE

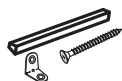

Separe as peças e acessórios de maneira organizada
 Separate parts and accessories in way organized
 Separe las piezas y accesorios de manera organizada



Forrar o chão com o papelão das embalagens
 Cover the floor with the cardboard
 Cubra el suelo con la embalaje de cartón



É necessário 1 pessoa para montar o produto
 It is necessary one person to assembly
 Es necesario una persona para ensamblar

Ferramentas necessárias
 (não fornecidas)
 Not include tools/
 No herramientas



CUIDADO PARA CONSERVAÇÃO E LIMPEZA DO MÓVEL
 CARE TO CONSERVATION AND CLEAN
 CUIDADO PARA LA CONSERVACIÓN Y LA LIMPIEZA

O peso máximo de carga informado refere-se a objetos distribuído de maneira uniforme sobre toda área de contato da peça.
 Set maximum weight load refers to objects distributed uniformly over the entire contact area of the workpiece.
 Conjunto de carga máxima de peso se refiere a objetos distribuidos uniformemente sobre toda el área de contacto de la pieza de trabajo.



Não molhar o móvel e não expor em lugar úmido
 Do not wet the mobile and do not expose in a wet place
 No moje el producto y no exponer en un lugar húmedo



Não expor o móvel próximo de fontes de calor
 Do not expose the mobile near heat sources
 no exponga cercano de fuentes de calor











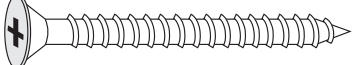







Não usar produtos abrasivos.
 Do not use abrasive products.
 No utilice productos abrasivos.

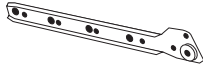

Limpe com flanela limpa e seca.
 Clean with dry cloth
 Limpieza con un paño limpio y seco

LISTA DE ACESSÓRIOS E FERRAGEM
ACCESSORIES AND HARDWARE / ACCESORIOS Y EQUIPOS

 A Cavilha - 6x30 madeira Dowel / Clavija	 B Parafuso 4,5x45 Screw / Tornillo	 C Parafuso -3,5x25 Screw / Tornillo	 D Parafuso -5,0x50 Screw / Tornillo	 E Parafuso -3,5x12 Screw / Tornillo			
 F Parafuso -3,0x12 Screw / Tornillo	 G Prego - 10x10 Nail / Clavo	 H Cantoneira Zamac Corner / Esquinero	 I Junção traseira metal Rear Junction / Unión	 J Sache cola 20g Glue / Goma	 K Puxador vazado branco Handle / Jalador	 L Rodízio chapa U branco Castros / Rueda	 M Corrediza metálica 350mm Slider / Corredera
 N Pê de madeira branco wood feet / Pies de madera	 O Parafuso minifix Minifix Screw / Tornillo minifix	 P Tambor minifix 12 mm Drum / Tambor	 Q Tampa minifix 15mm Cover / Tapa	 R Rolly Kit Rolly Kit	 albatroz móveis Logomarca Logo		

LISTA DE PEÇAS / List of Pieces / Lista de piezas

Nº	DESCRIÇÃO DE PEÇA	DESCRIPTION	DESCRIPCIÓN	MAT. PRIMA	MEDIDAS	QTD
1	BASE	BASE	BASE	MDP	450x450x15	1
2	LATERAL ESQUERDA	LEFT SIDE	LATERAL IZQUIERDA	MDP	600x450x15	1
3	LATERAL DIREITA	RIGHT SIDE	LATERAL DERECHA	MDP	600x450x15	1
4	PRATELEIRA	SHELF	REPISA	MDP	420x450x15	1
5	TAMPO	TOP	TAMPO	MDP	450x450x15	1
6	LATERAL MESA	TABLE SIDE	LATERAL MESA	MDP	671x354x15	1
7	TRAVA DA MESA	TABLE LOCK	TRAVA DA MESA	MDP	350x200x15	1
8	TAMPO MESA	TABLE TOP	TAMPO MESA	MDP	1355x358x25	1
9	FRENTE GAVETA	FRONT DRAWER	FRENTE CAJON	MDP	446x298x15	1
10	LATERAL GAVETA	DRAWER SIDE	LATERAL CAJON	MDP	380x140x12	2
11	CONTRA FUNDO	BACKGROUND	CONTRAFONDO	MDP	371x130x12	1
12	FUNDO GAVETA	BACK DRAWER	FONDO CAJON	HDF	394x385x03	1
13	FUNDO	BACK SIDE	FONDO	HDF	311x448x03	2

PASSO 1 Fixar as peças 02 e 03 na peça 01 utilizando as ferragens (B).

STEP 1 Fix the pieces 02 & 03 in the piece 01 using the tools (B).

PASO 1 Fije las piezas 02 y 03 en la pieza 01 usando las herrages (B).

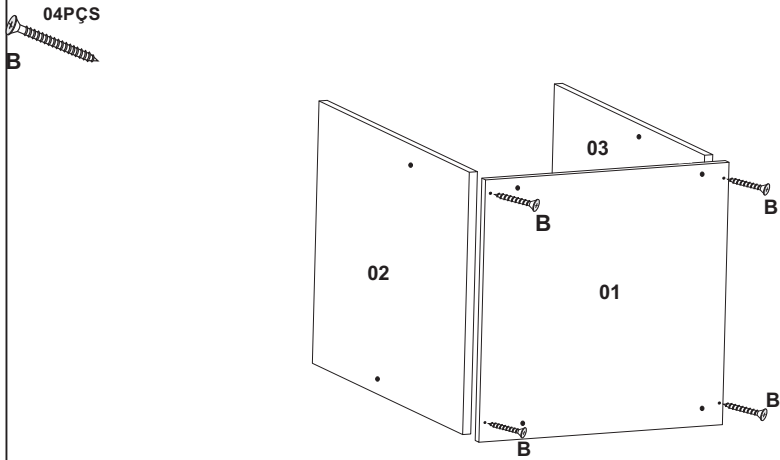

PASSO 2 Fixar a peça 4 nas peças 2 e 3 utilizando a ferragem (B). Fixar o acessório (M) nas peças 2 e 3 utilizando a ferragem (E). Fixar a peça 5 nas peças 2 e 3 utilizando as ferragens (A, E e H).

STEP 2

PASO 2

Fix the 4 in the 2 & 3 using (B). Fix the (M) in the 2 & 3 using (E). Fix 5 in the 2 & 3 using (A, E & H).

04PÇS



A

04PÇS



B

04PÇS



H

08PÇS



E

01PÇ



M

06PÇ



F

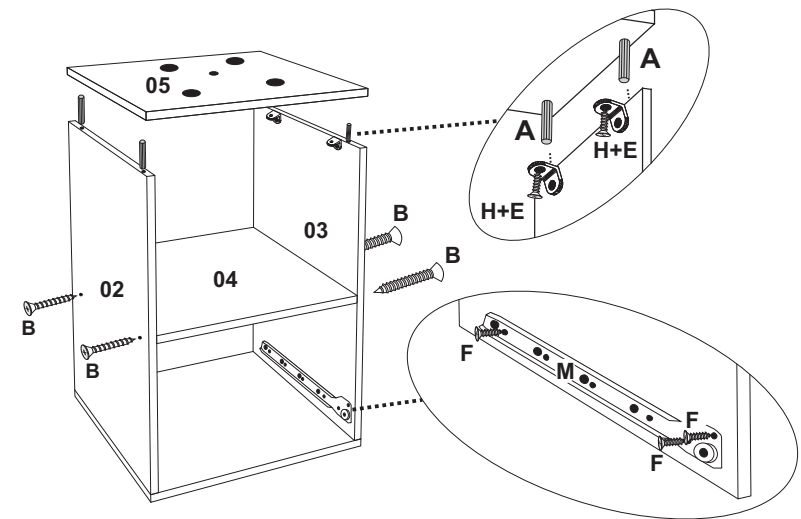

PASSO 3 Preguar as peças 13 utilizando a ferragem (J) para unir as duas peças.

STEP 3 Nail the 13 using (J) to join the two pieces

PASO 3 Clavee las 13 usando la (J) para unir las dos piezas

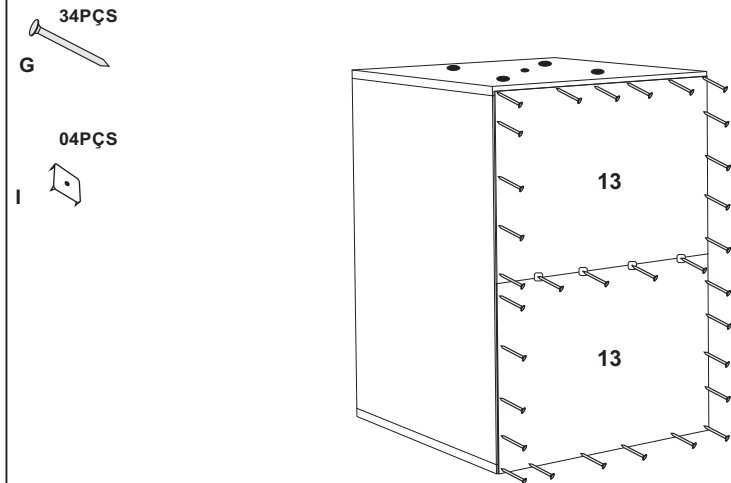

PASSO 4 Fixar o acessório (N) na peça 01 utilizando a ferragem (D)

STEP 4 Fix the (N) in the 01 using (D)

PASO 4 Fije (N) en la 01 usando (D)

04PÇS



N

04PÇS



D

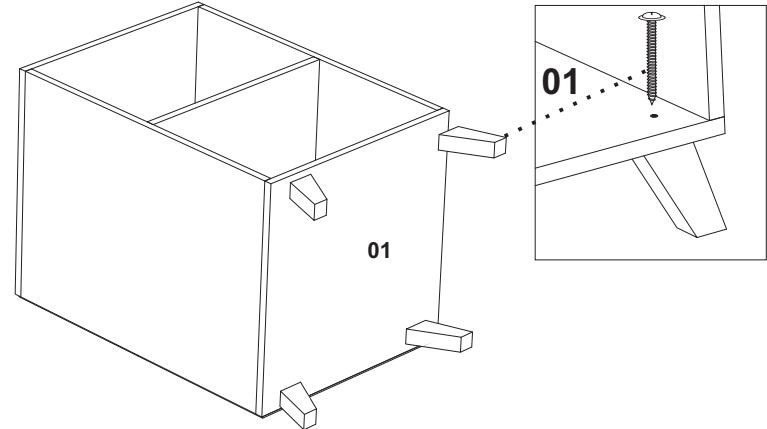

PASSO 5 Fixar as peças 07 na peça 06 utilizando as ferragens (O, P e Q). Depois fixe a peça 6 na peça 08 utilizando ferragens (O,P e Q) em seguida fixe a peça 07 na peça 08 utilizando ferragens (A,H,E)

STEP 5 Fix the 07 in the 06 using (O, P & Q). After fix the 6 in the 08 using (O,P & Q). Fix 07 in the 08 using (A,H,E)

PASO 5 Fije la 07 en la 06 usando (O, P y Q). Despues fije la 06 en la 08 usando (O,P y Q). Fije la 07 en la 08 usando (A,H,E)

Fije la 07 en la 06 usando (O, P y Q). Despues fije la 06 en la 08 usando (O,P y Q). Fije la 07 en la 08 usando (A,H,E)

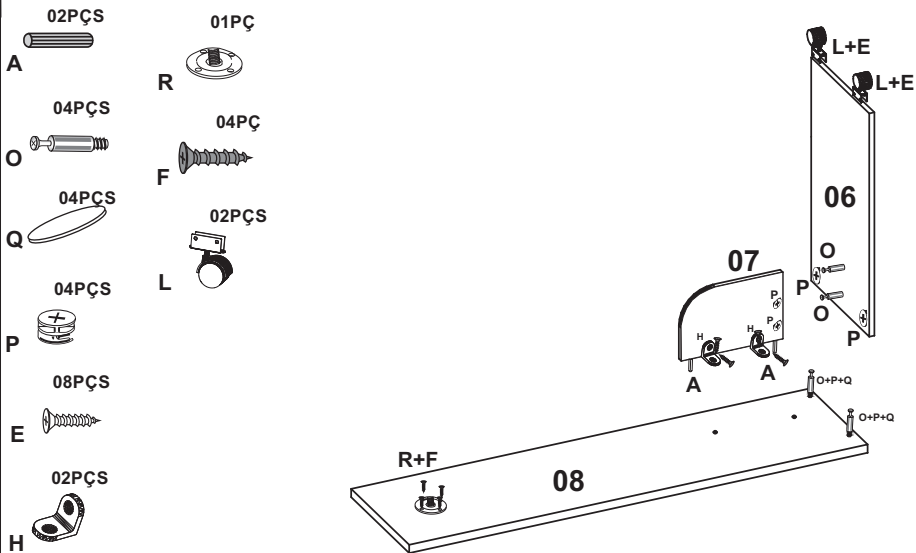

PASSO 6 Fixar acessório na peça 05 utilizando as ferragens (F).

STEP 6 Fix the accessory in the 05 using (F).

PASO 6 Fije el accesorio en la 05 usando (F).

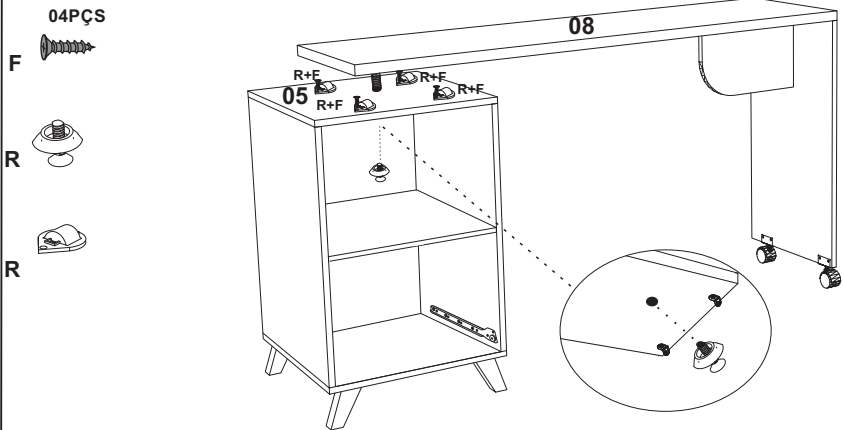

PASSO 1 Fixar a peça 10 na peça 09 utilizando as ferragens (A,E,H,J). Depois fixar a peça 11 na peça 10 utilizando as ferragens C.

STEP 1 Fix the 10 in the 09 using (A,E,H,J). After fix the 11 in the 10 using (C).

PASO 1 Fije la 10 en la 09 usando (A,E,H,J). Despues fije la 11 en la 10 usando (C).

MONTAGEM DA GAVETA S/ CHAVE
DRAWER ASSEMBLY / MONTAJE DE CAJON

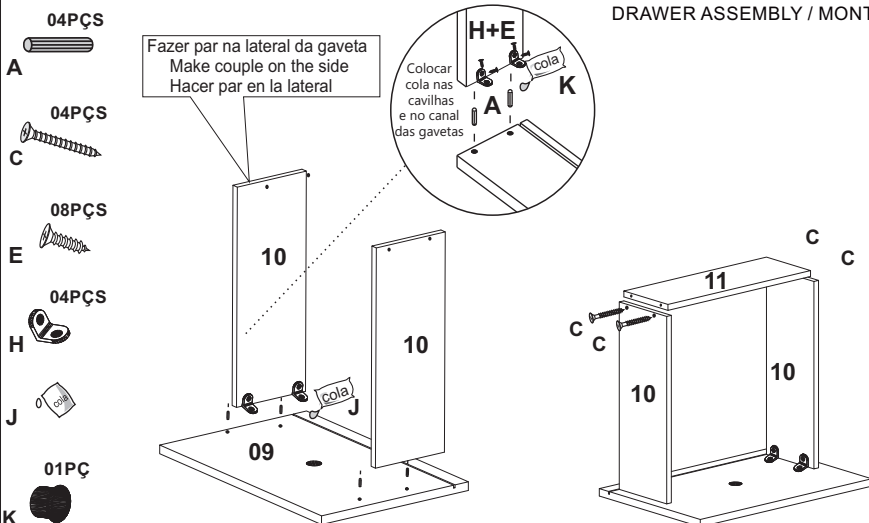

PASSO 2 Fixar a peça 12 na peça 10 e 11 utilizando as ferragens (G,F). Depois a ferragens M na peça 10 utilizando a ferragem (F).

STEP 2 Fix the 12 in the 10 & 11 using the (G,F). After (M) in the 10 using (F).

PASO 2 Fije la 12 en la 10 y 11 usando (G,F). Despues la (M) en la 10 usando (F).

