

# ASSEMBLY INSTRUCTIONS

## MANUAL DE MONTAGEM / INSTRUCCIONES DE ARMADO

Santa Mônica office table - 1 drawer  
 Mesa Santa Mônica - 1 gaveta  
 Escritorio Santa Mônica - 1 cajón

Reference 190720 | Revise 00  
 Referência 190720 | Revisão 00  
 Referencia 190720 | Revisión 00

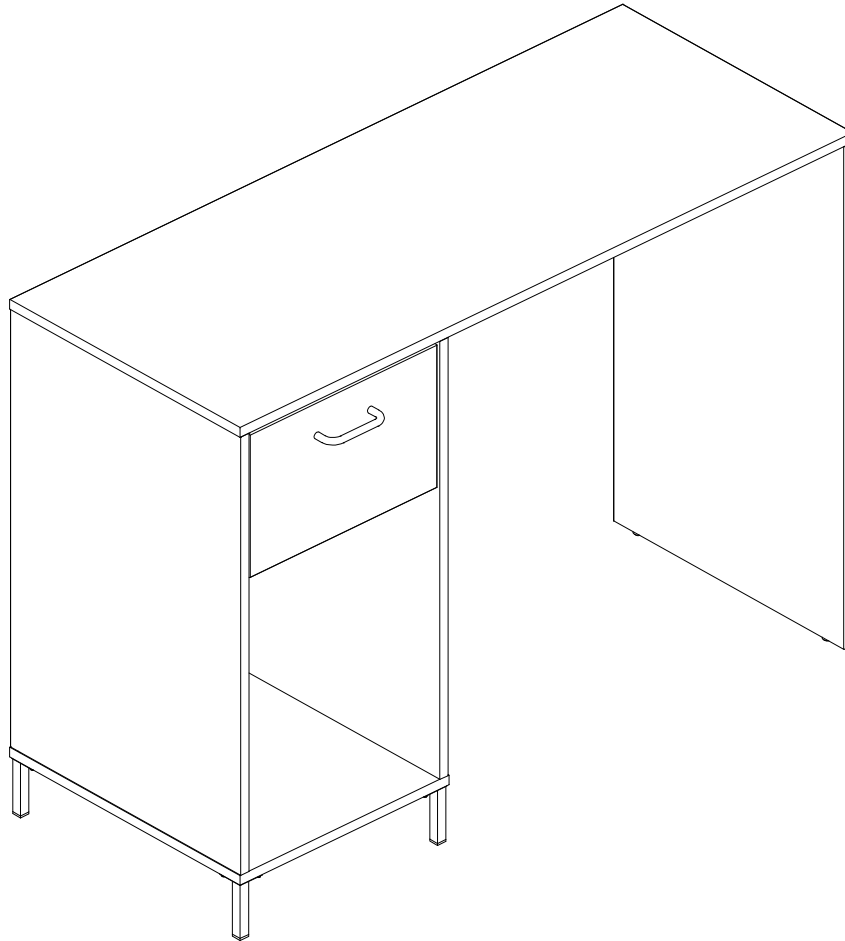

### YOU WILL NEED / VOCÊ VAI PRECISAR DE / USTED NECESITARÁ

#### Tools not supplied / Ferramentas não fornecidas / Herramientas no incluidas

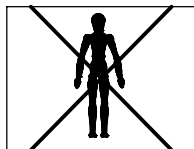

1 Person  
 1 Pessoa  
 1 Persona

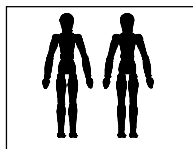

2 People  
 2 Pessoas  
 2 Personas

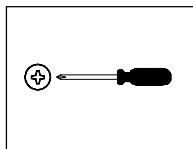

Screwdriver Phillips  
 Chave Phillips  
 Destornillador cruz

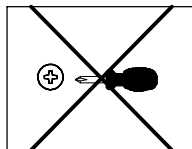

Small screwdriver Phillips  
 Chave Phillips Menor  
 Destornillador cruz menor

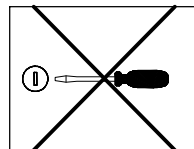

Screwdriver slotted  
 Chave fenda  
 Destornillador plano

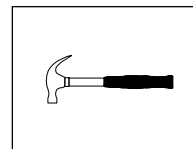

Hammer  
 Martelo  
 Martillo

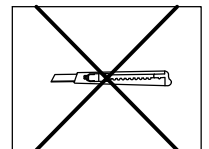

Stylet  
 Estilete  
 Estilete

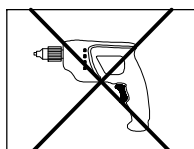

Drill machine  
 Furadeira  
 Taladro

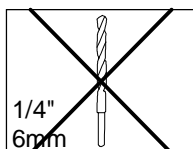

1/4"  
 6mm  
 Drill bit  
 Broca  
 Taladro

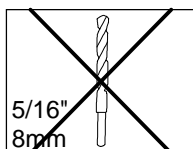

5/16"  
 8mm  
 Drill bit  
 Broca  
 Taladro

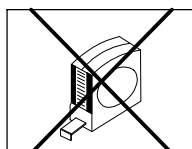

Measuring tape  
 Trena  
 Cinta de medición

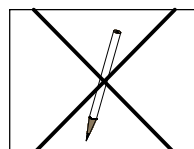

Pencil  
 Lápis  
 Lápis

**NOTES:** The separation of the accessories before you start the assembly will facilitate the same. In case of doubt on the size of the screws and bolts, use the ruler to bottom of page 3.

**NOTAS:** A separação dos acessórios antes de iniciar a montagem facilitará a mesma. Em caso de dúvida no tamanho dos parafusos e cavilhas, utilize a régua ao final da página 3.

**NOTAS:** La separación de los accesorios antes de comenzar el armado facilitará el mismo. En caso de duda sobre el tamaño de los tornillos y taquetes, utilice la regla al pie de página 3.

MAXIMUM RECOMMENDED WEIGHT  
BEING THIS EVENLY DISTRIBUTED

PESO MÁXIMO RECOMENDADO SENDO  
ESTE DISTRIBUÍDO UNIFORMEMENTE

PESO MÁXIMO RECOMENDADO SIENDO  
ESTE UNIFORMEMENTE DISTRIBUIDO

	LB	KG
<b>A</b>	33	15
<b>B</b>	22	10
<b>C</b>	11	5

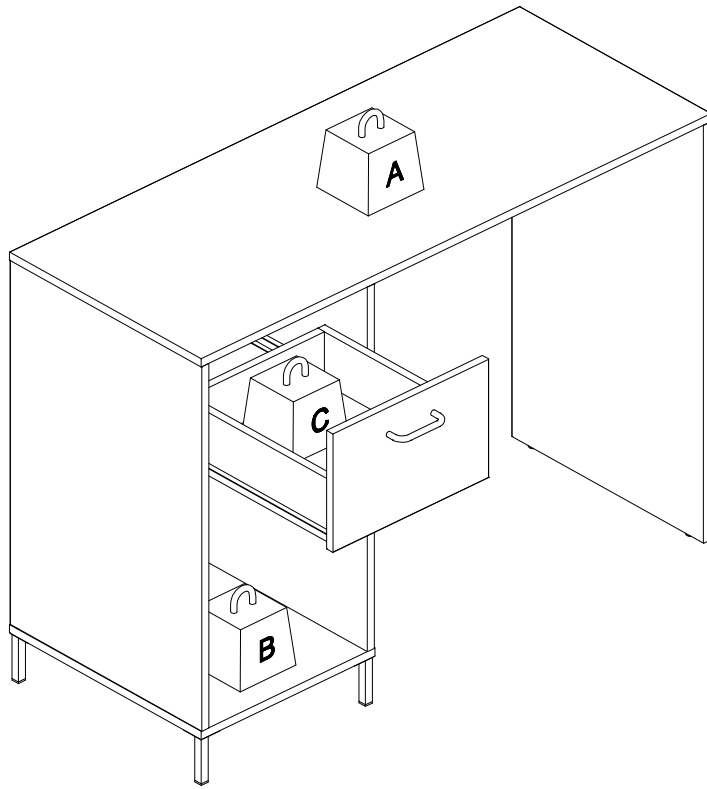





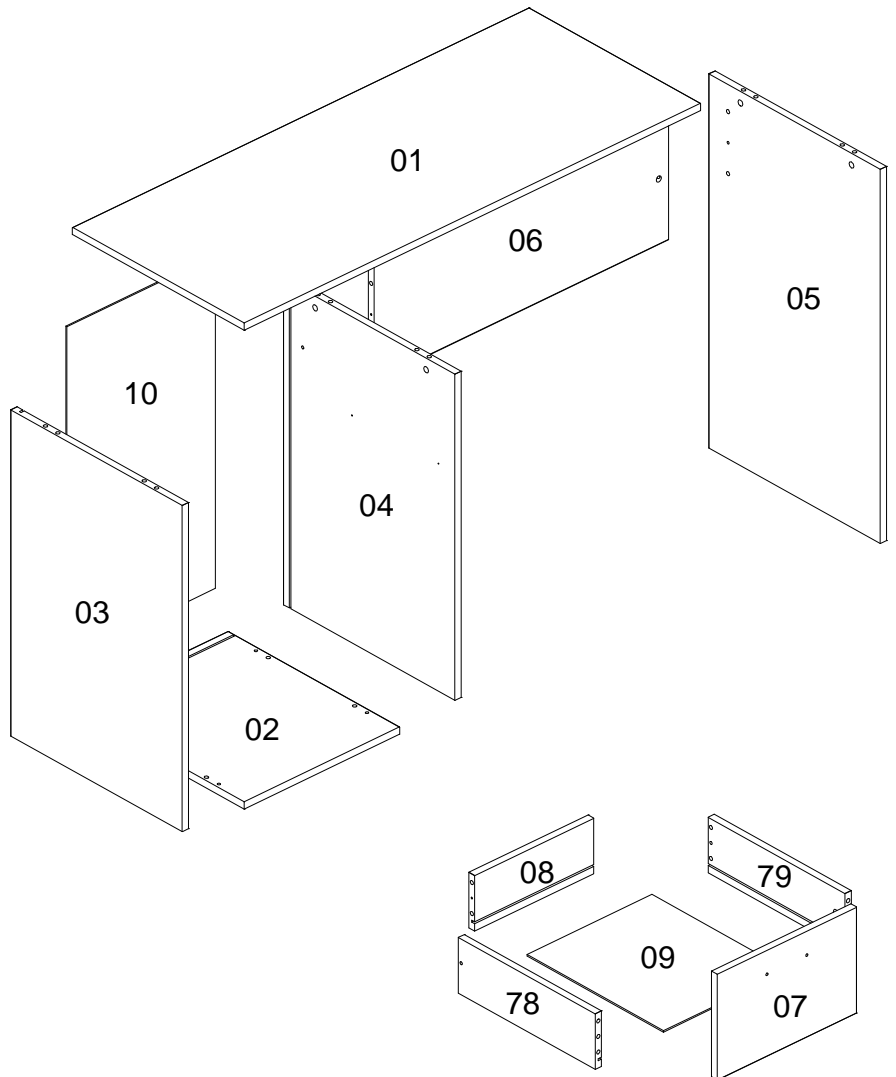





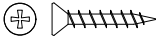
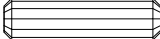
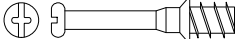

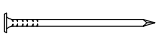
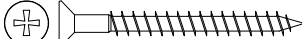

Nº	Measures Inches	Medidas cm	Qty./Qtd.
01	43 1/4 x 17 1/2 x 5/8	110 x 44,5 x 1,5	1
02	14 3/4 x 17 1/2 x 5/8	37,5 x 44,5 x 1,5	1
03	26 1/2 x 17 1/2 x 5/8	67,3 x 44,5 x 1,5	1
04	26 1/2 x 17 1/2 x 5/8	67,3 x 44,5 x 1,5	1
05	30 3/8 x 17 1/2 x 5/8	77,2 x 44,5 x 1,5	1
06	28 x 10 x 5/8	71 x 25,5 x 1,5	1
07	13 1/4 x 8 5/8 x 5/8	33,6 x 21,9 x 1,5	1
08	11 1/4 x 4 1/2 x 5/8	28,7 x 11,5 x 1,5	1
09	11 7/8 x 13 7/8 x 5/8	30,1 x 35,4 x 0,3	1
10	27 x 14 1/8 x 5/8	68,7 x 35,8 x 0,3	1
78	14 x 4 1/2 x 5/8	35,5 x 11,5 x 1,5	1
79	14 x 4 1/2 x 5/8	35,5 x 11,5 x 1,5	1

**PARTS IDENTIFICATION**  
**IDENTIFICAÇÃO DAS PEÇAS / IDENTIFICACIÓN DE LAS PIEZAS**

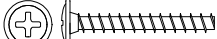
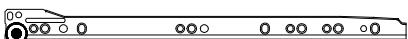
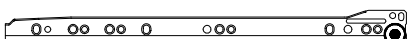

# IDENTIFICATION OF ACCESSORIES IDENTIFICAÇÃO DOS ACESSÓRIOS/ IDENTIFICACIÓN DE ACCESORIOS

A1		Glue / Cola / Pegamento	13 g	1
A2		Small plastic foot / Sapata redonda / Pie plástico	14 mm	2
A8		Flat head screw / Parafuso chato / Tornillo de cabeza plana	3,5x20 mm	4
E		Wooden dowel / Cavilha / Taquete	8x30 mm	22
J		Simple minifix screw / Haste minifix simples / Tornillo minifix simple	-	9
L		Drum lock / Tambor minifix / Tambor minifix	12 mm	9
L13		Foot / Pé tubular / Pie	87x15 mm	4
M		Bore patch adhesive / Tapa furo adesivo / Tapones adhesivo	-	5
N		Nail / Prego / Clavo	10x10	2
O		Flat head screw / Parafuso chato / Tornillo de cabeza plana	4,5x45 mm	7
o1		Triangular support / Suporte triangular / Soporte triangular	-	4
P5		Flat head screw / Parafuso chato especial / Tornillo de cabeza plana	3,5x14 mm	8
S		Pan head screw / Parafuso panela / Tornillo de pan	3,5x14 mm	12
T		Flanged head screw / Parafuso flangeado / Tornillo de cabeza flangeada	3,5x25 mm	2
VA		Metallic slide the left field / Corrediça lateral esquerda / Corredera lateral izquierda	350 mm	1
VB		Metallic slide the right field / Corrediça lateral direita / Corredera lateral derecha	350 mm	1
VC		Drawer slide left / Corrediça gaveta esquerda / Corredera izquierda cajón	350 mm	1
VD		Drawer slide right / Corrediça gaveta direita / Corredera derecha cajón	350 mm	1
W7		Handle / Puxador Goleira / Tirador	96 mm	1



PRE-ASSEMBLE  
PRÉ-MONTAGE / PRE ARMADO

01

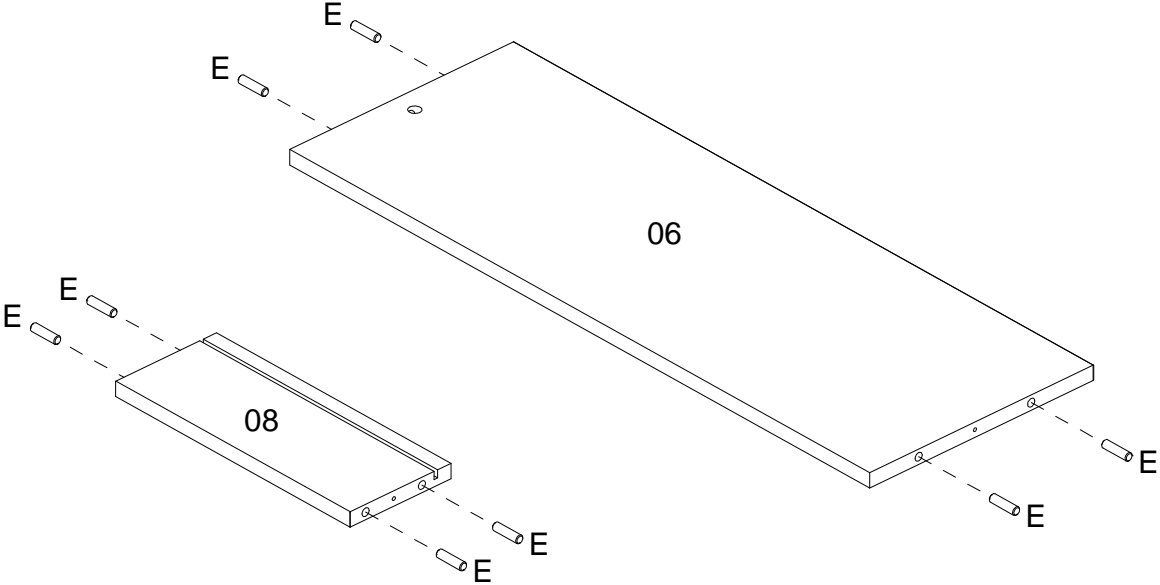
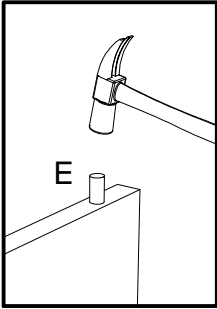

02

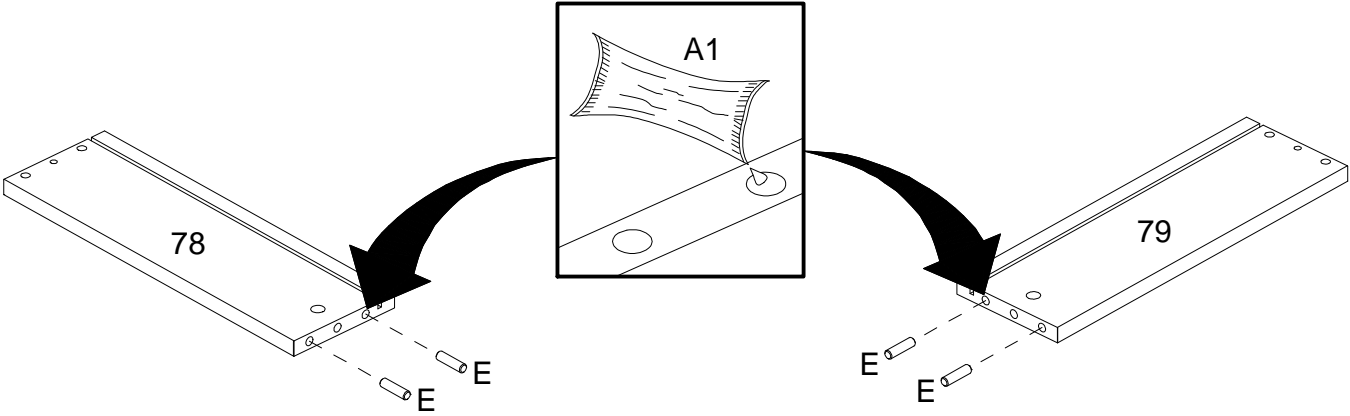

03

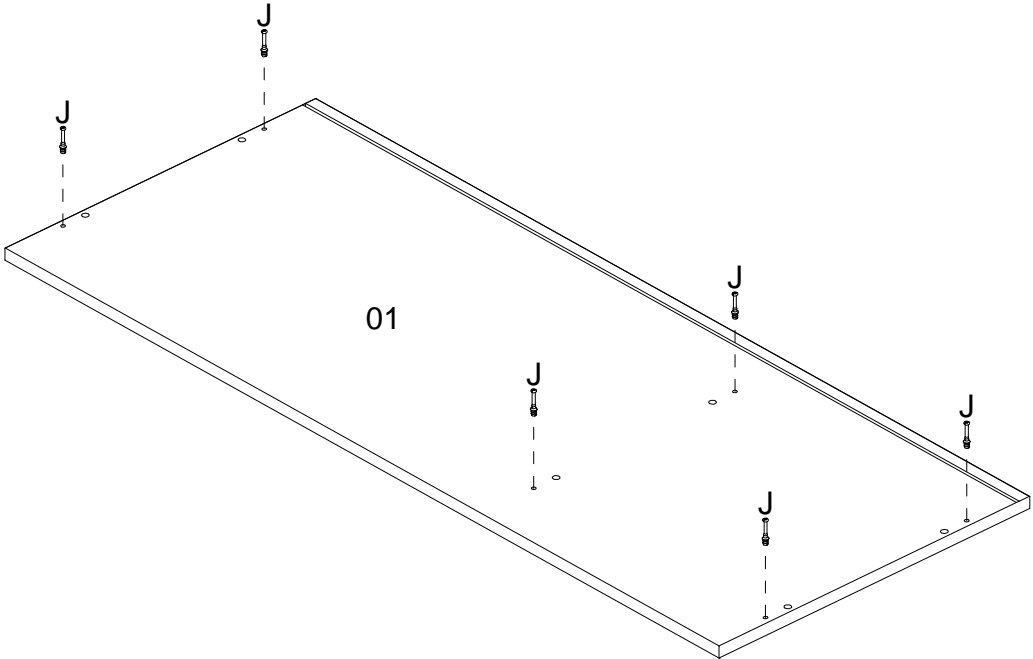
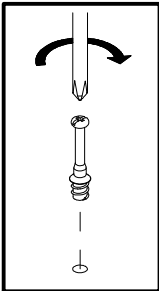

04

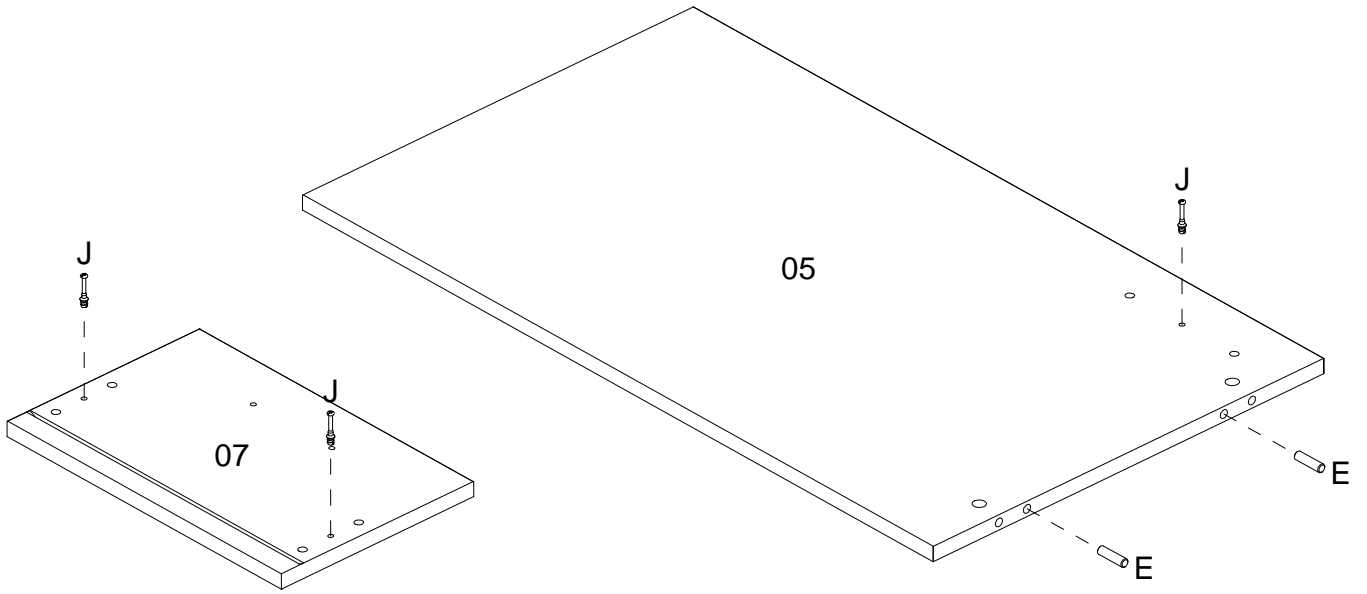

05

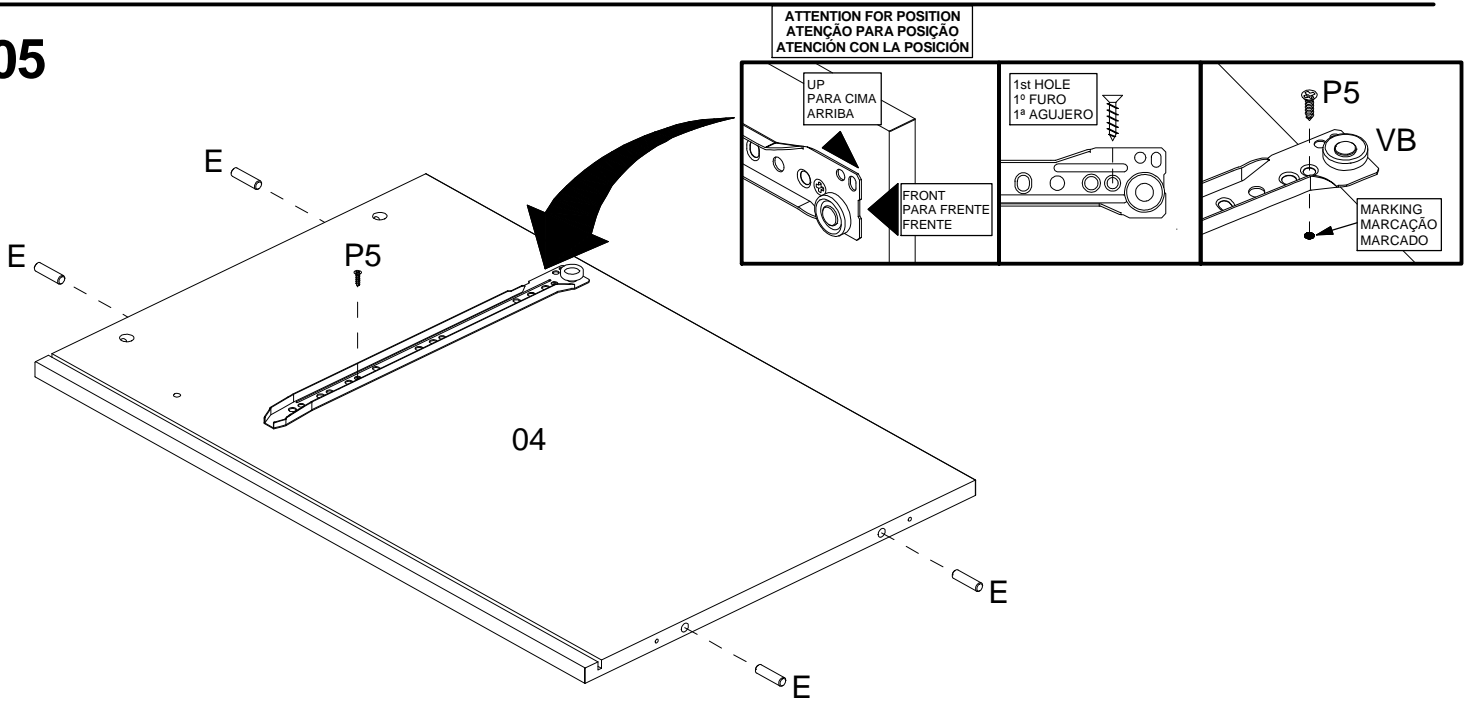

06

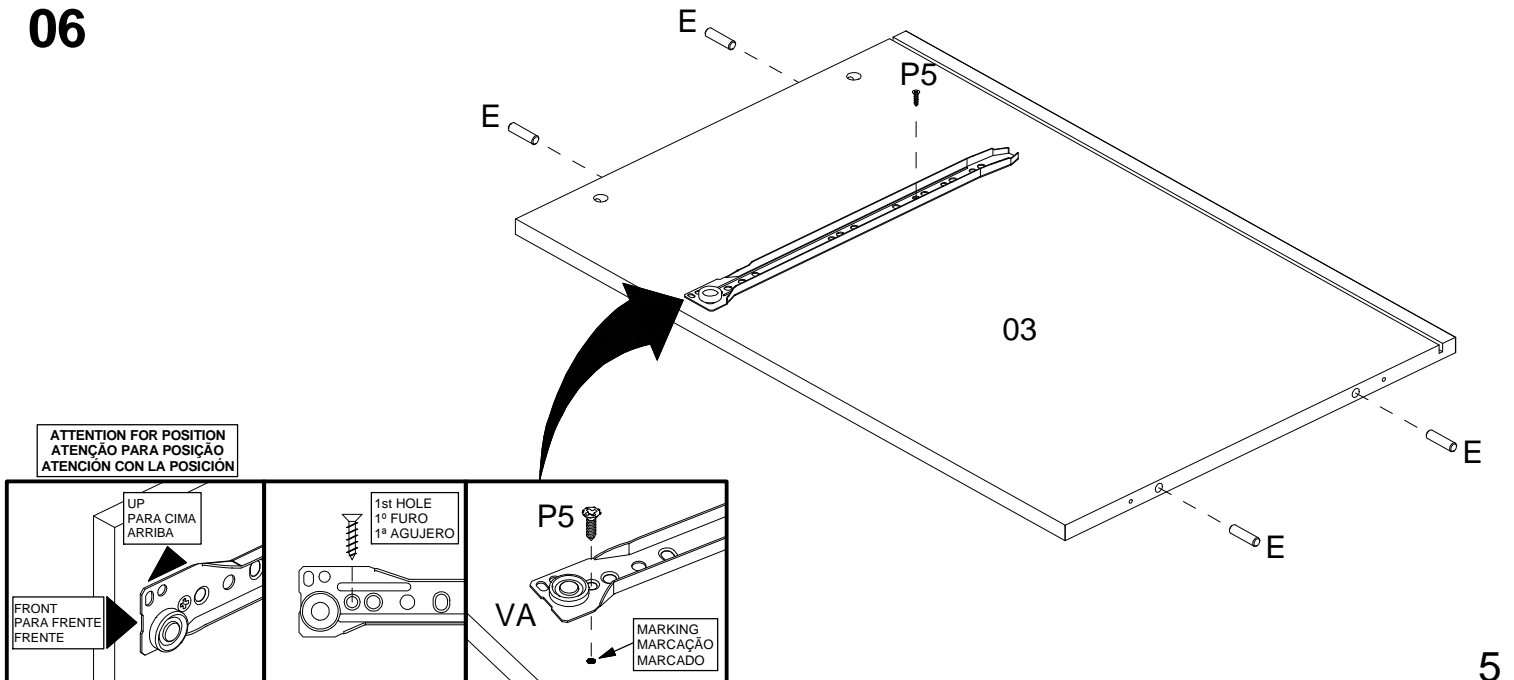

ASSEMBLY  
MONTAGEM / ARMADO

07

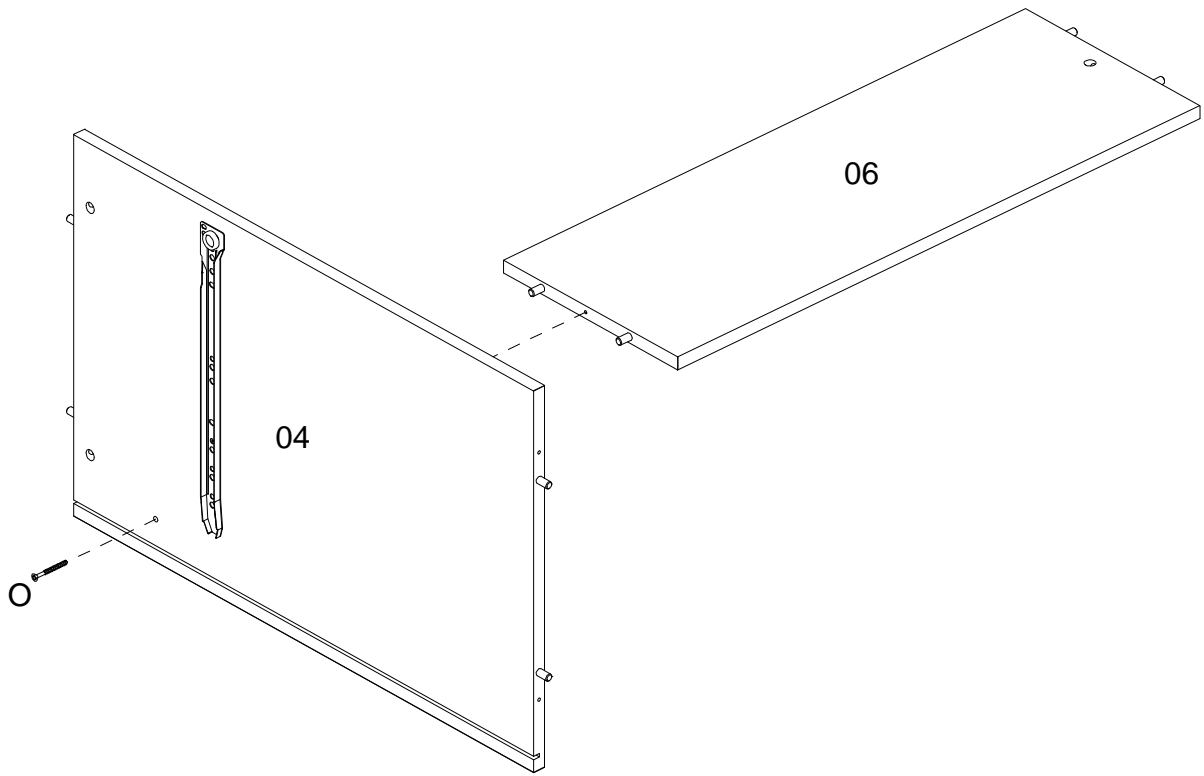

08

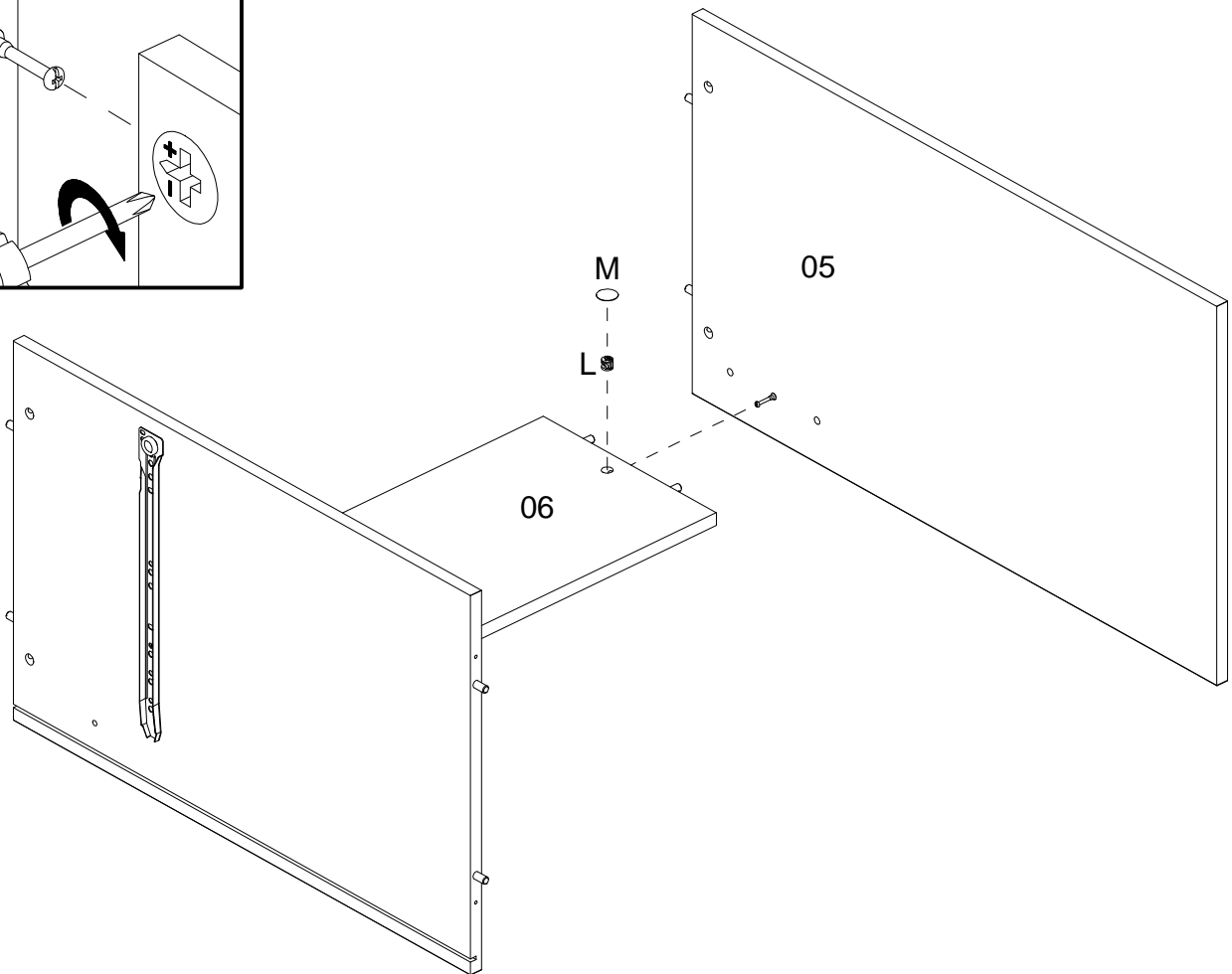
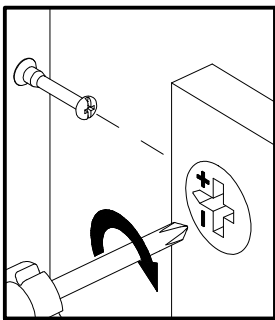

09

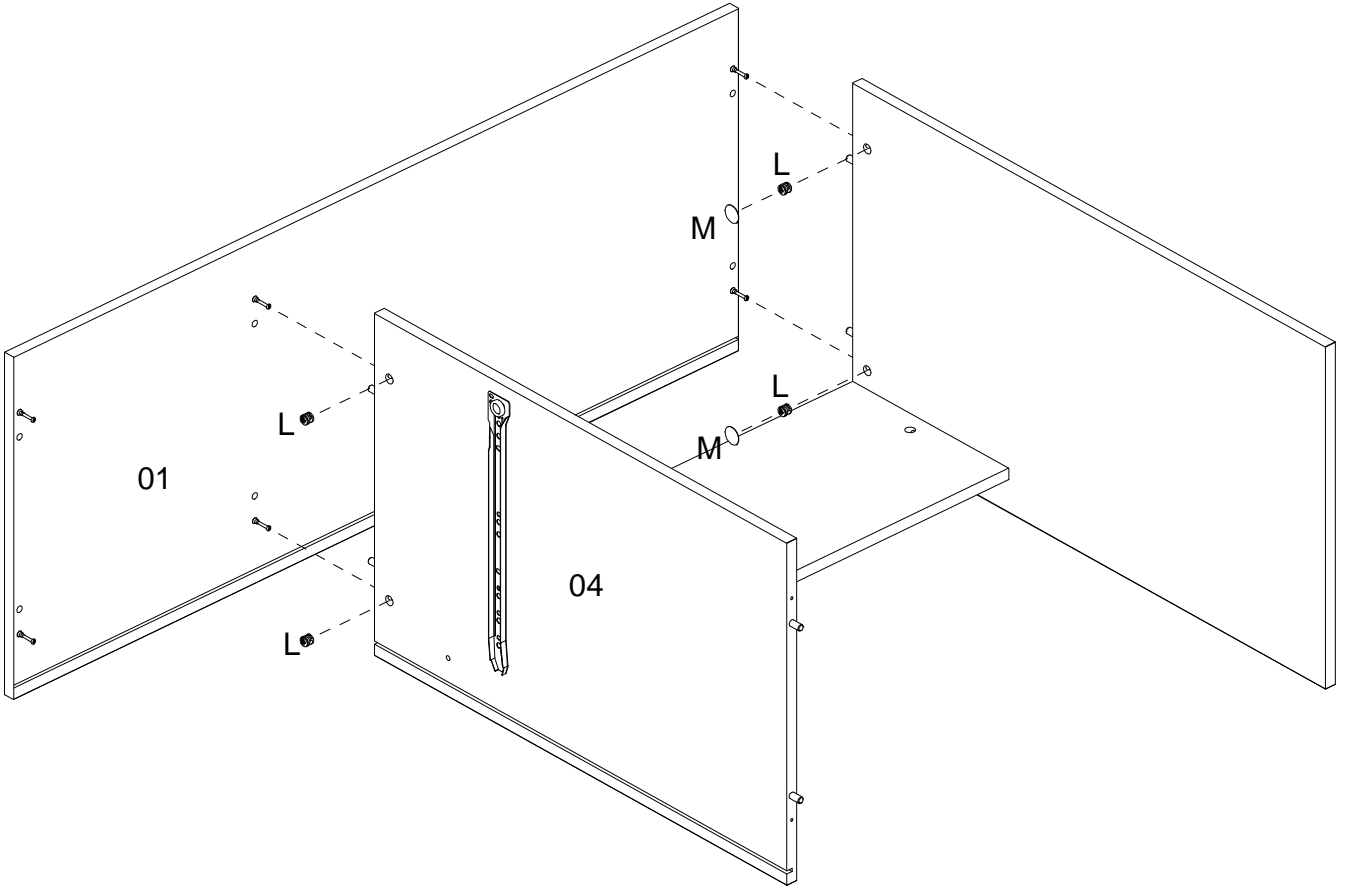

10

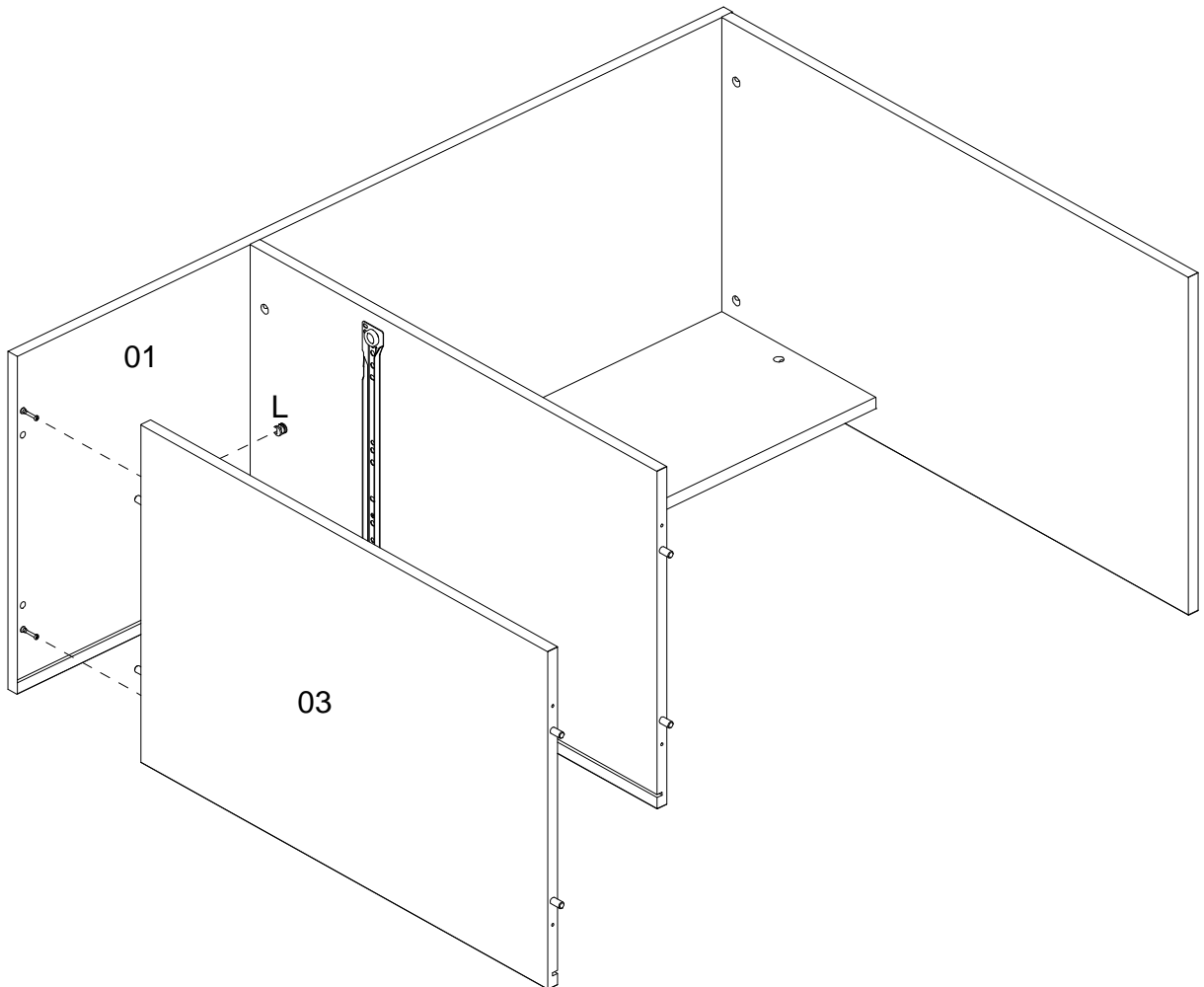

11

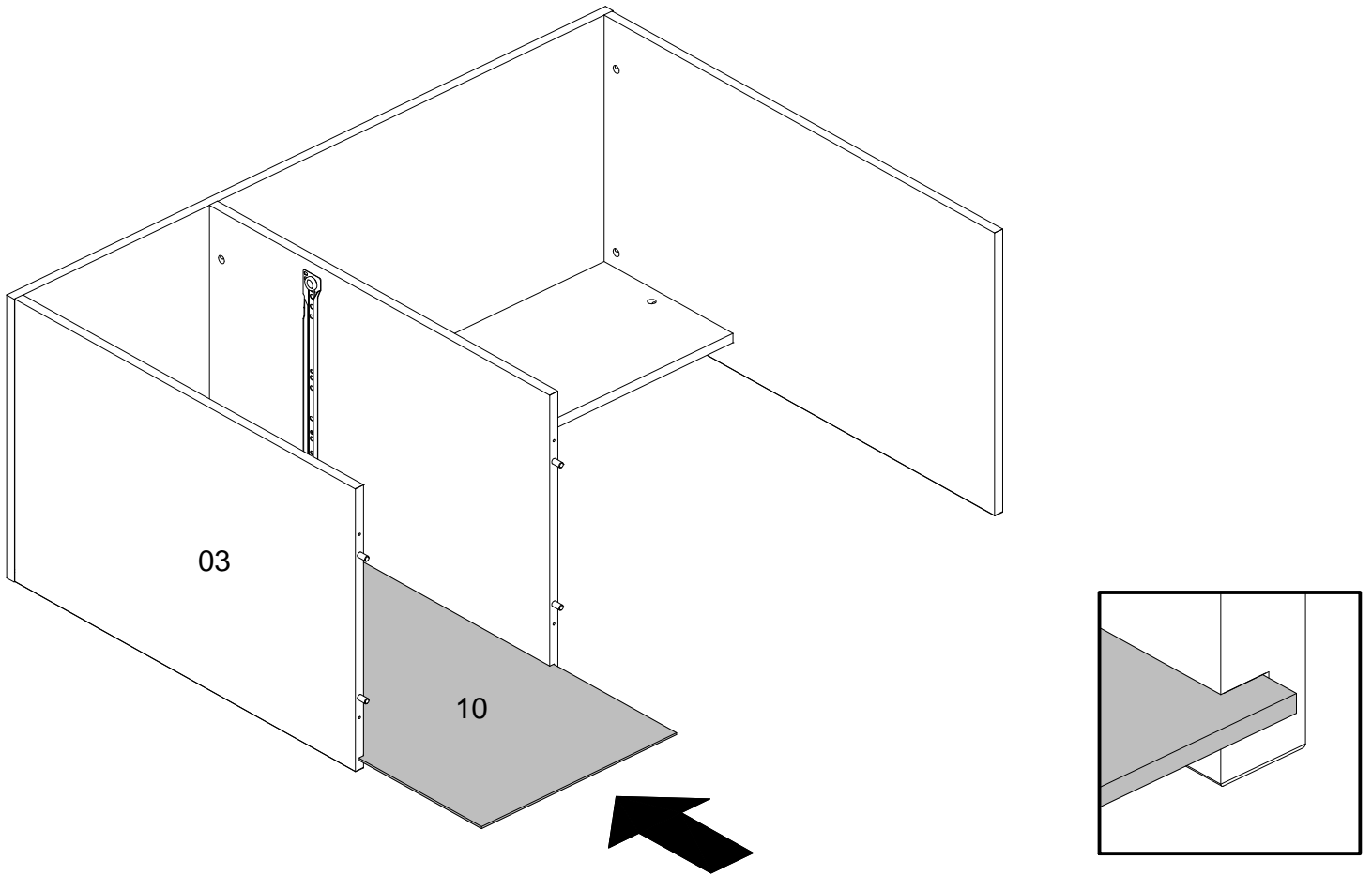

12

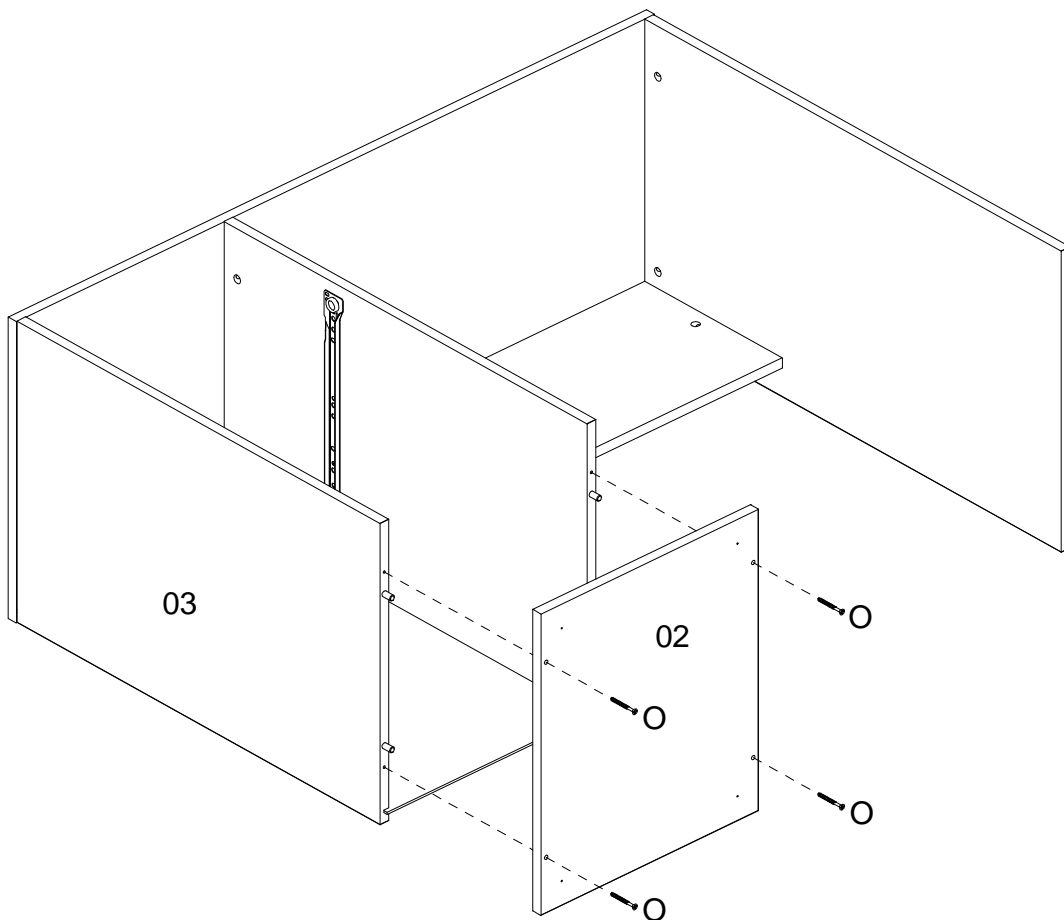



13

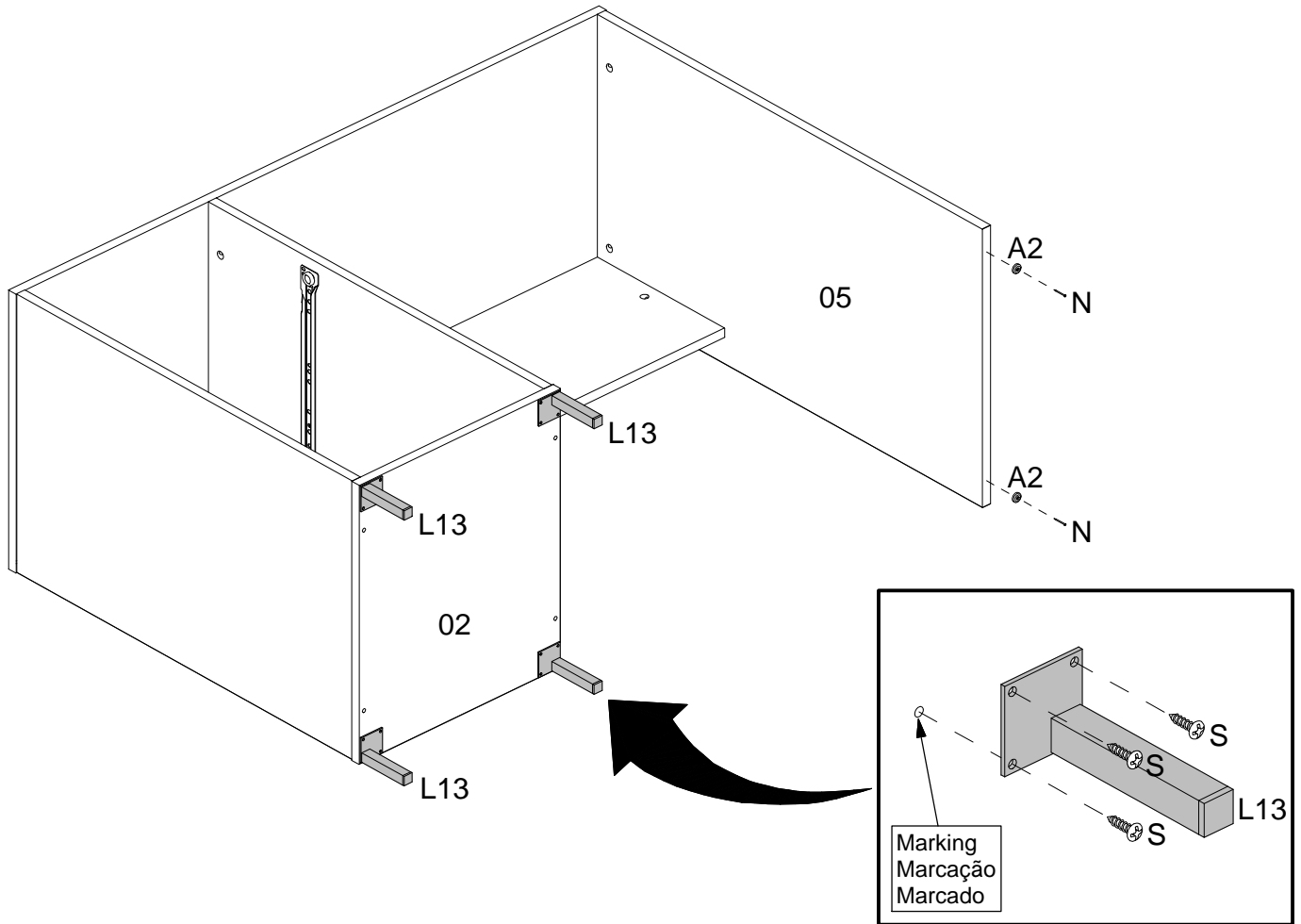

14

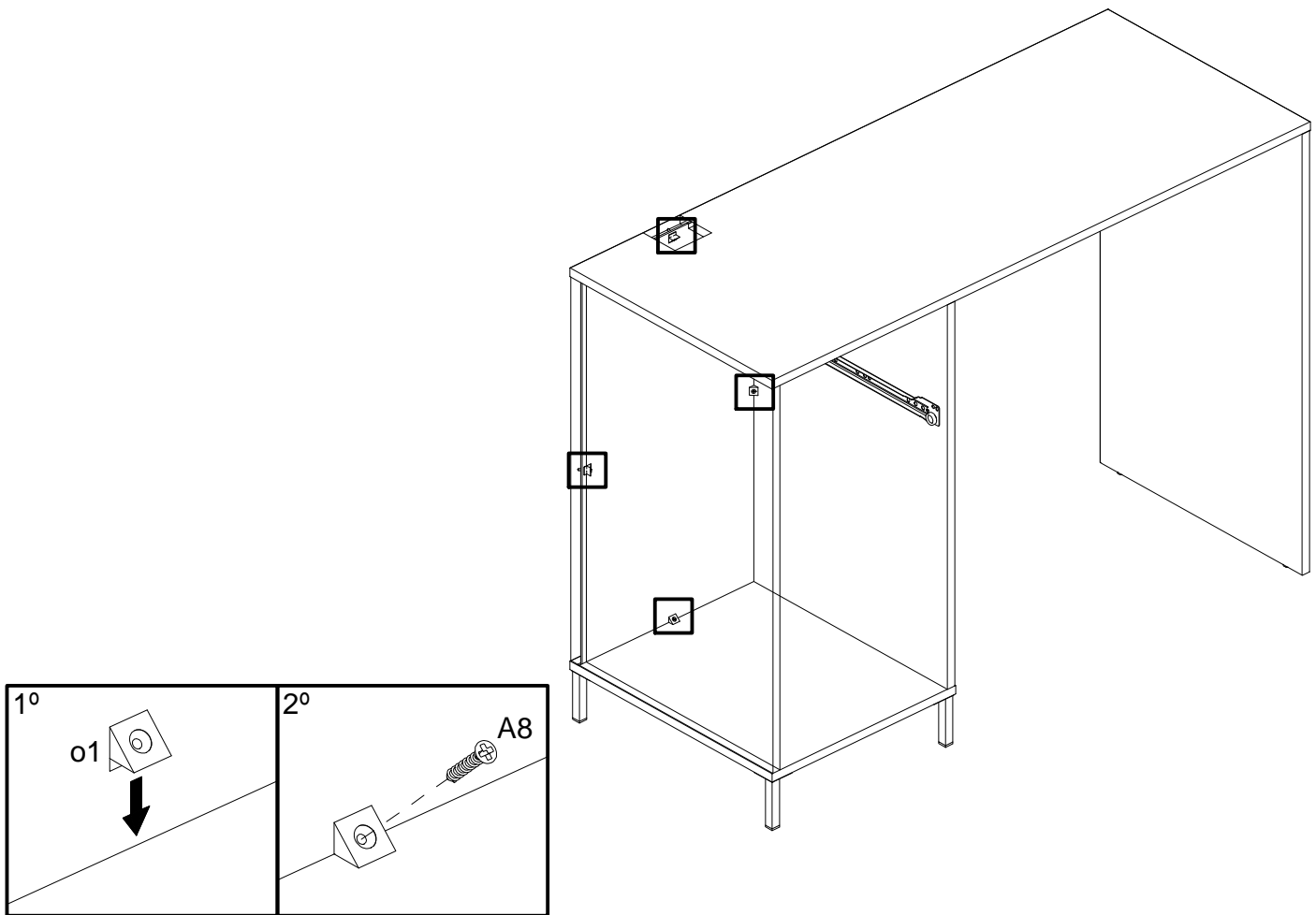

15

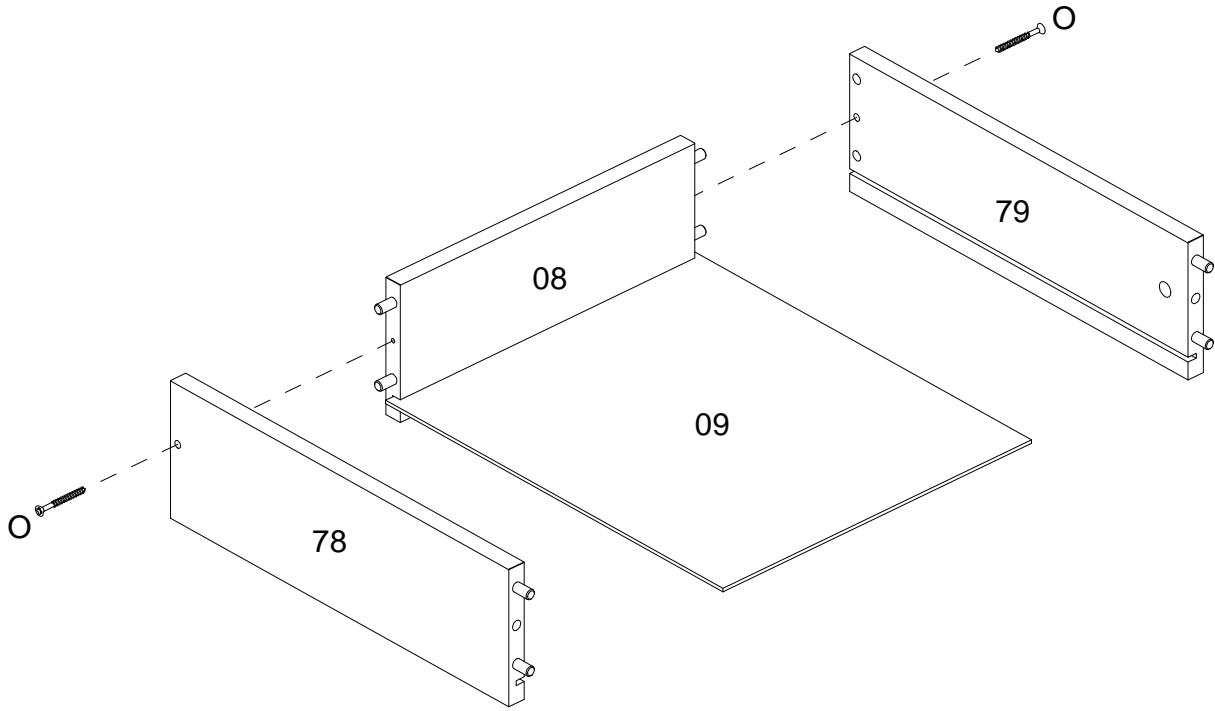

16

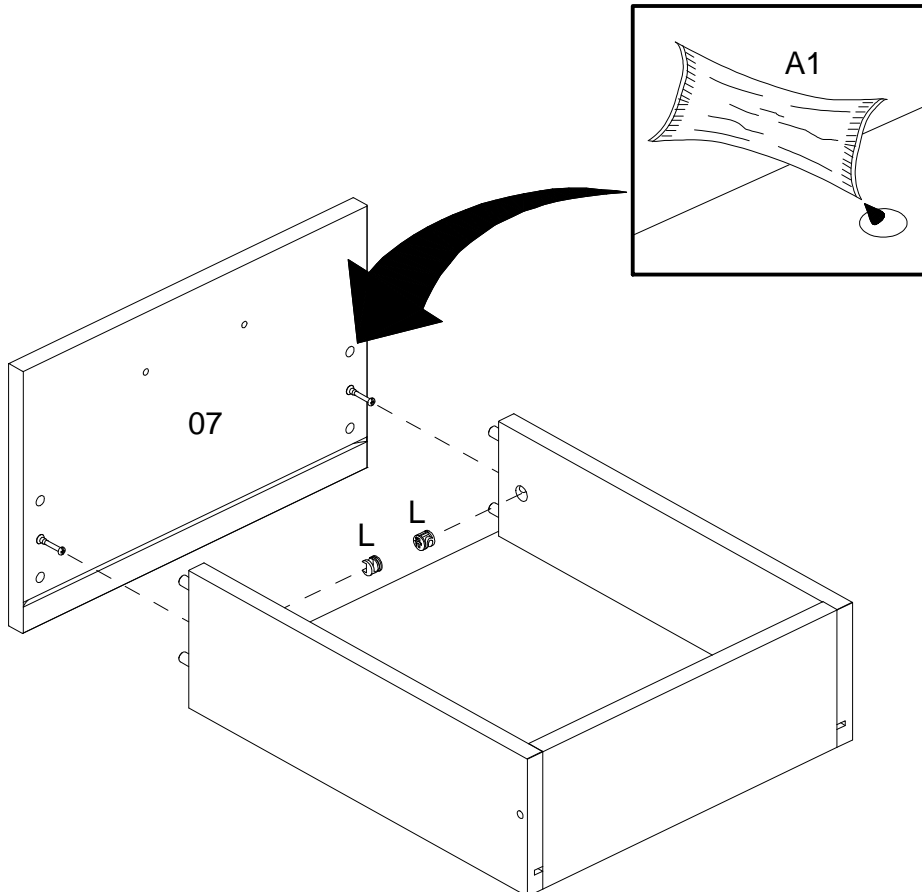

17

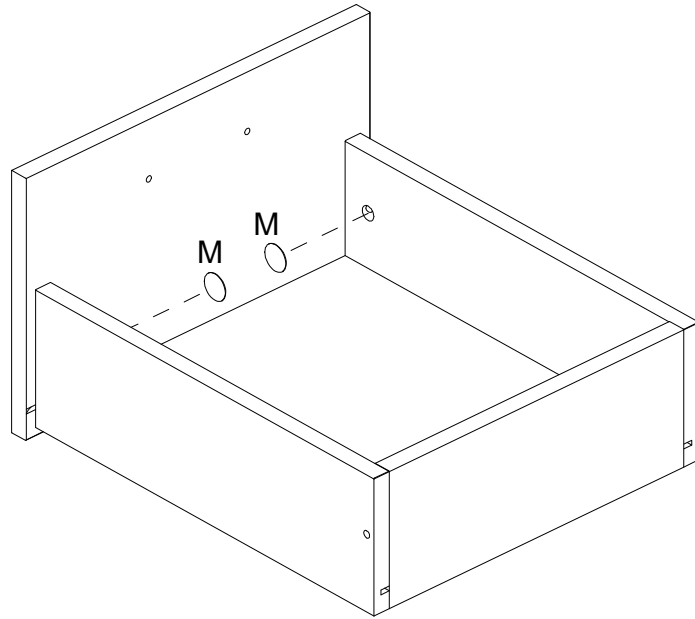

---

18

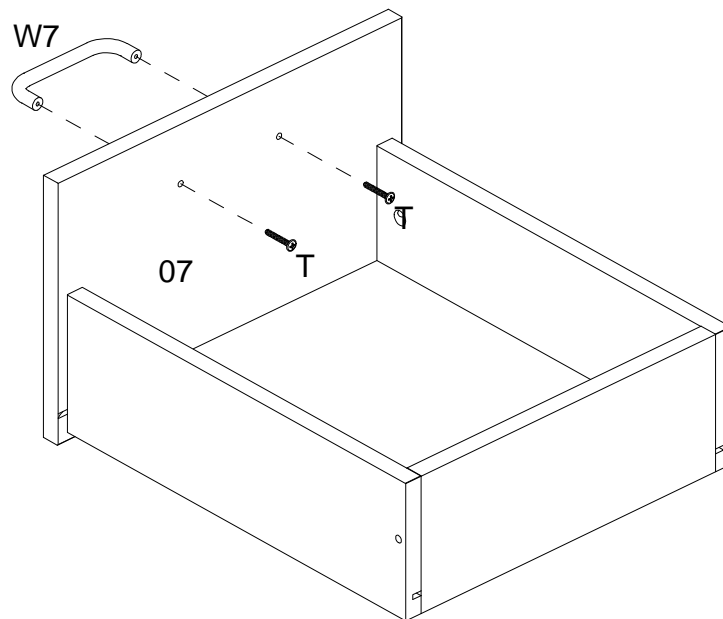

19

THE UNDERSIDE OF THE DRAWER  
LADO INFERIOR DA GAVETA  
PARTE INFERIOR DEL CAJÓN

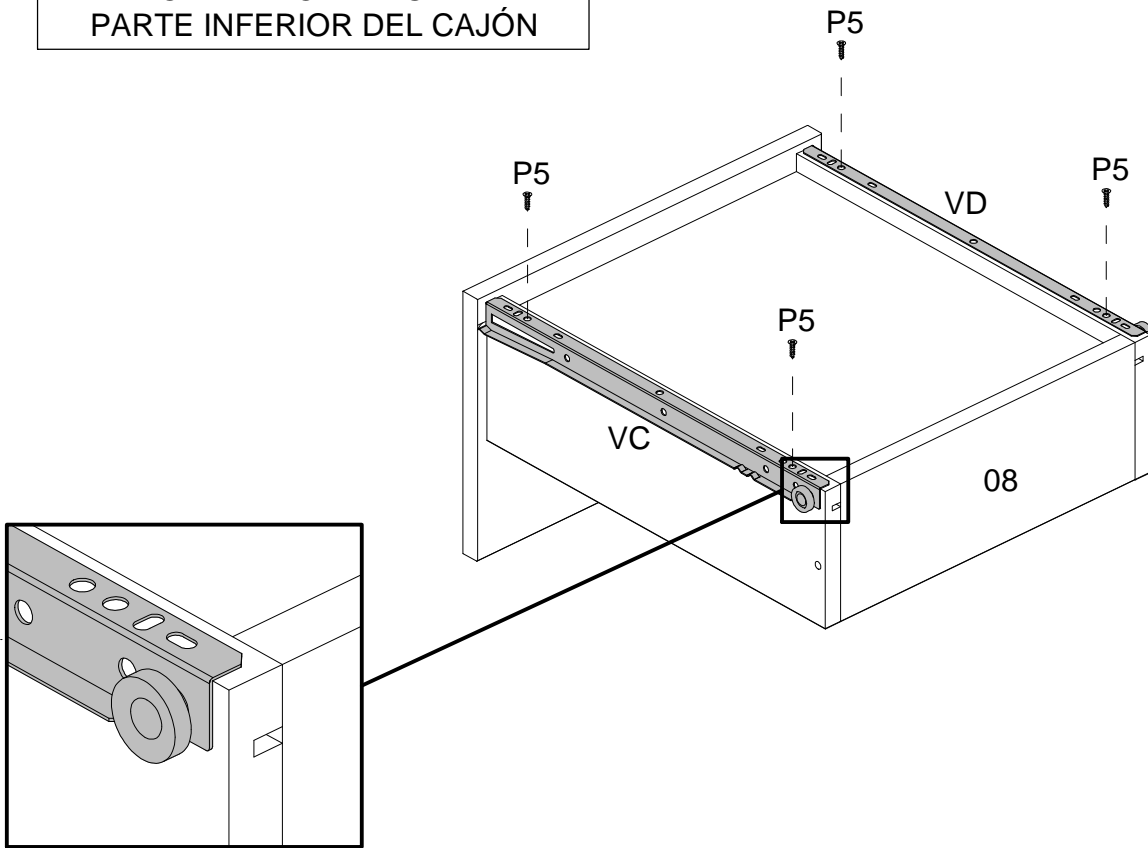

20

