

# MANUAL DE MONTAGEM

ASSEMBLY INSTRUCTIONS / INSTRUCCIONES DE ARMADO

MESA MACAU  
MACAU office table  
Escritorio MACAU

Código 180573 | Revisão 00

Português  
English  
Español

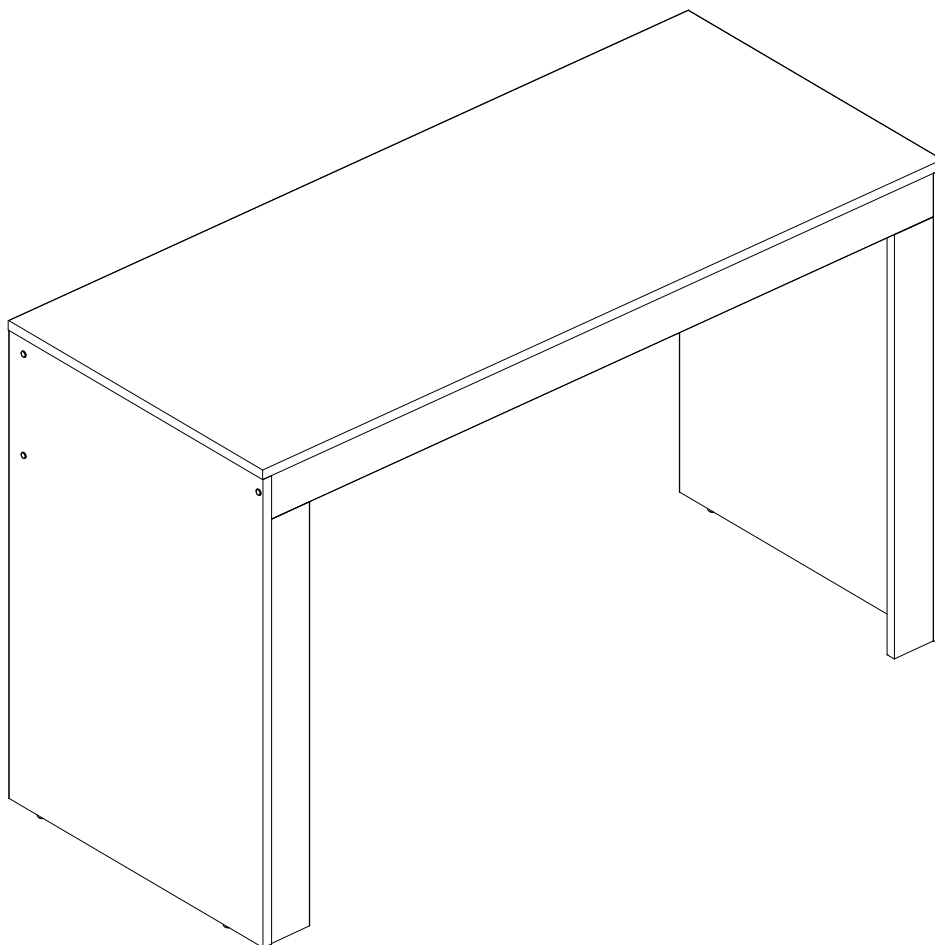

## VOCÊ VAI PRECISAR DE / YOU WILL NEED / USTED NECESITARÁ

### Ferramentas não fornecidas / Tools not supplied / Herramientas no incluidas

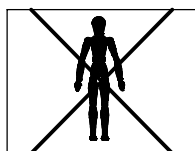

1 Pessoa  
1 Person  
1 Persona

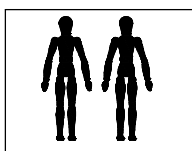

2 Pessoas  
2 People  
2 Personas

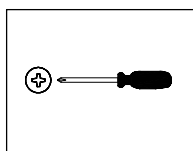

Chave Phillips  
Screwdriver Phillips  
Destornillador cruz

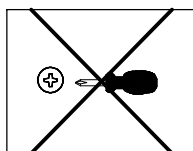

Chave Phillips Menor  
Small screwdriver Phillips  
Destornillador cruz menor

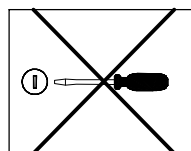

Chave fenda  
Screwdriver slotted  
Destornillador plano

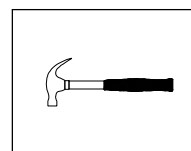

Martelo  
Hammer  
Martillo

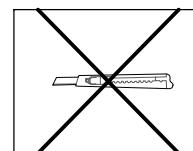

Estilete  
Stylet  
Estilete



Furadeira  
Drill machine  
Taladro

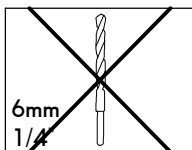

Broca  
Drill bit  
Taladro

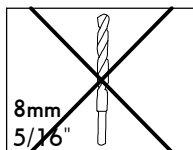

Broca  
Drill bit  
Taladro

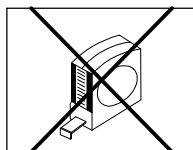

Trena  
Measuring tape  
Cinta de medición

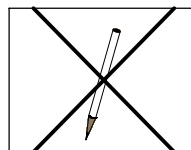







Lápis  
Pencil  
Lápiz

**NOTAS:** A separação dos acessórios antes de iniciar a montagem facilitará a mesma. Em caso de dúvida no tamanho dos parafusos e cavilhas, utilize a régua ao final da página 2.

**NOTES:** The separation of the accessories before you start the assembly will facilitate the same. In case of doubt on the size of the screws and bolts, use the ruler to bottom of page 2.

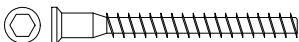
**NOTAS:** La separación de los accesorios antes de comenzar el armado facilitará el mismo. En caso de duda sobre el tamaño de los tornillos y taquetes, utilice la regla al pie de página 2.

IDENTIFICAÇÃO DOS ACESSÓRIOS/ IDENTIFICATION OF ACCESSORIES/ IDENTIFICACIÓN DE ACCESORIOS

<b>A2</b>		Sapata redonda / Small plastic foot / Pie plástico	14 mm	<b>4</b>
<b>B5</b>		Cantoneira de metal / Metalic angle plates / Suporte de metal	46 mm	<b>6</b>
<b>B6</b>		Junção de tampos / Junction of tops / Unión de tapas	40x40 mm	<b>2</b>
<b>E</b>		Cavilha / Wooden dowel / Taquete	8x30 mm	<b>10</b>
<b>G</b>		Parafuso estrutural / Structural screw / Tornillo estructural	50x50 mm	<b>6</b>
<b>H</b>		Chave allen / Allen key / Liave allen	3 mm	<b>1</b>
<b>I</b>		Tampa parafuso estrutural / Structural screw cover / Tapa tornillo estructural	-	<b>6</b>
<b>J</b>		Haste minifix simples / Simple minifix screw / Tornillo minifix simple	-	<b>4</b>
<b>L</b>		Tambor minifix / Drum lock / Tambor minifix	12 mm	<b>4</b>
<b>N</b>		Prego / Nail / Clavo	10 x10	<b>4</b>
<b>S</b>		Parafuso panela / Pan head screw / Tornillo de pan	3,5x14 mm	<b>32</b>



IDENTIFICAÇÃO DAS PEÇAS / PARTS IDENTIFICATION/ IDENTIFICACIÓN DE LAS PIEZAS

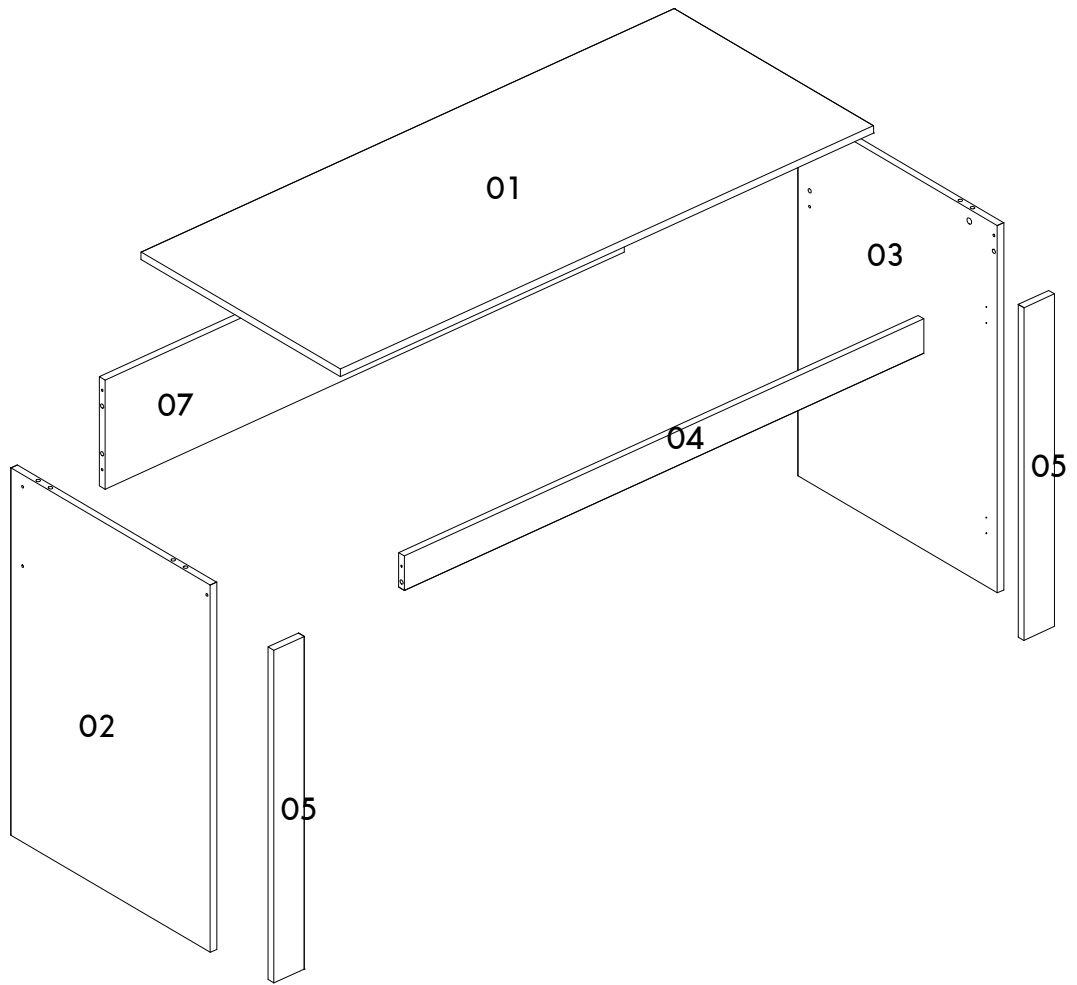

Número / Number / Número	Medidas / Measures / Medidas		Qtd. / Qty. / Qtd.
	cm	inches	
01	122,5 x 52 x 1,5	48" 1/4 x 20" 1/2 x 5/8	1
02	74 x 52 x 1,5	29" 1/8 x 20" 1/2 x 5/8	1
03	74 x 52 x 1,5	29" 1/8 x 20" 1/2 x 5/8	1
04	119,3 x 7 x 1,5	47" x 2" 3/4 x 5/8	1
05	67 x 7 x 1,5	26" 3/8 x 2" 3/4 x 5/8	2
07	119,3 x 22 x 1,5	47" x 8" 5/8 x 5/8	1

01

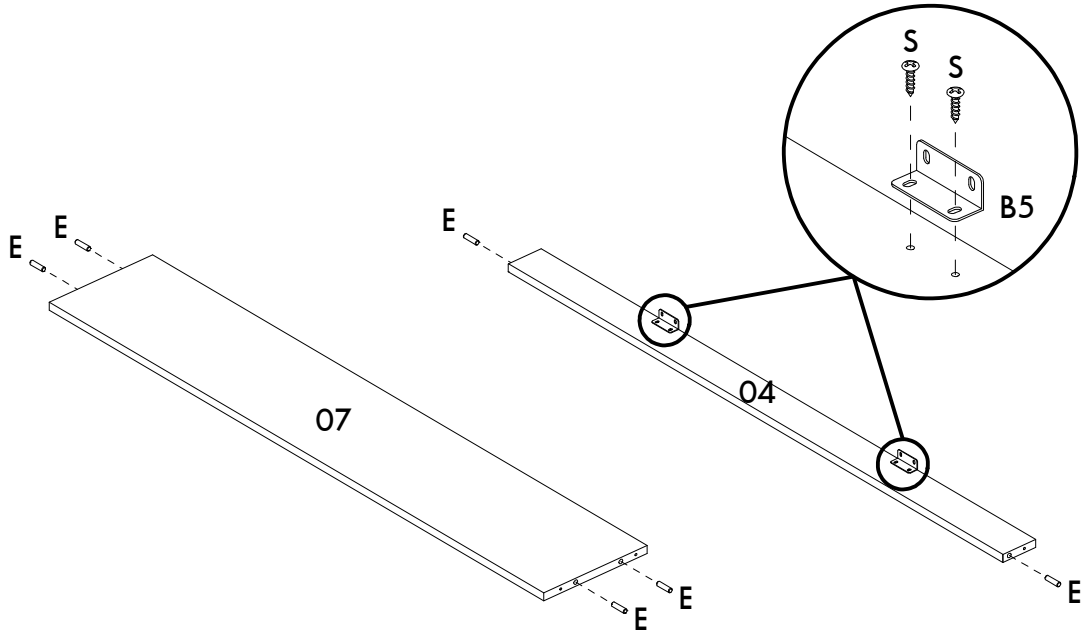
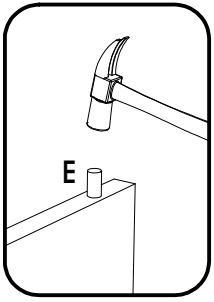

02

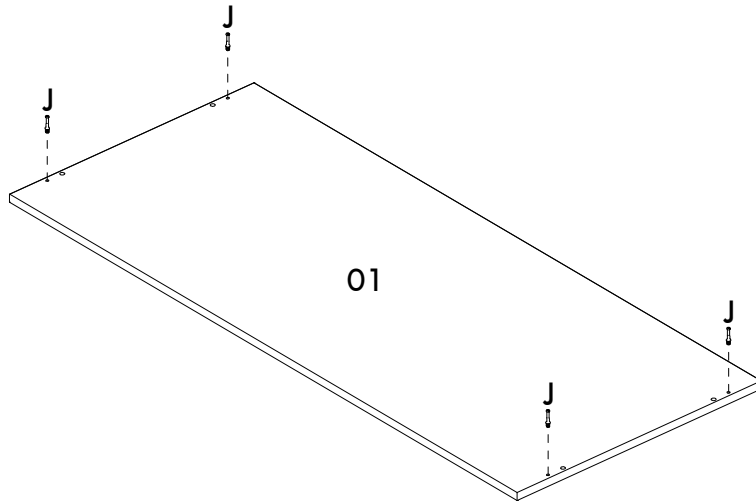
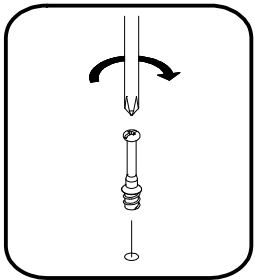

03

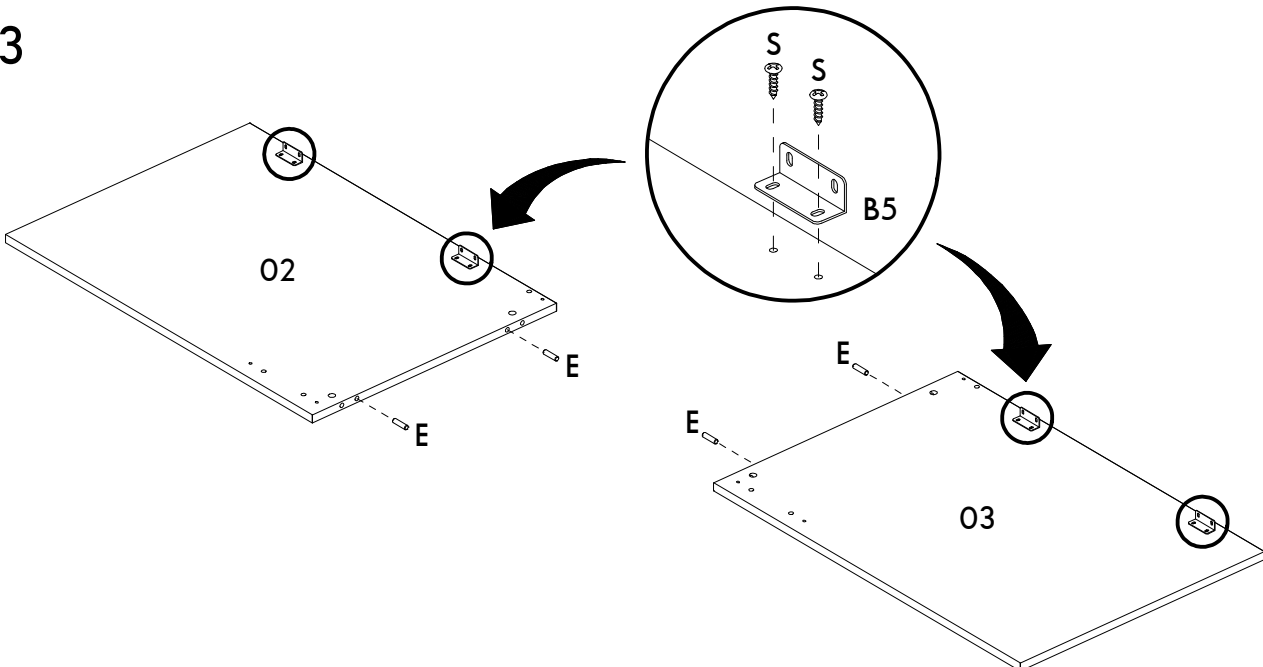

04

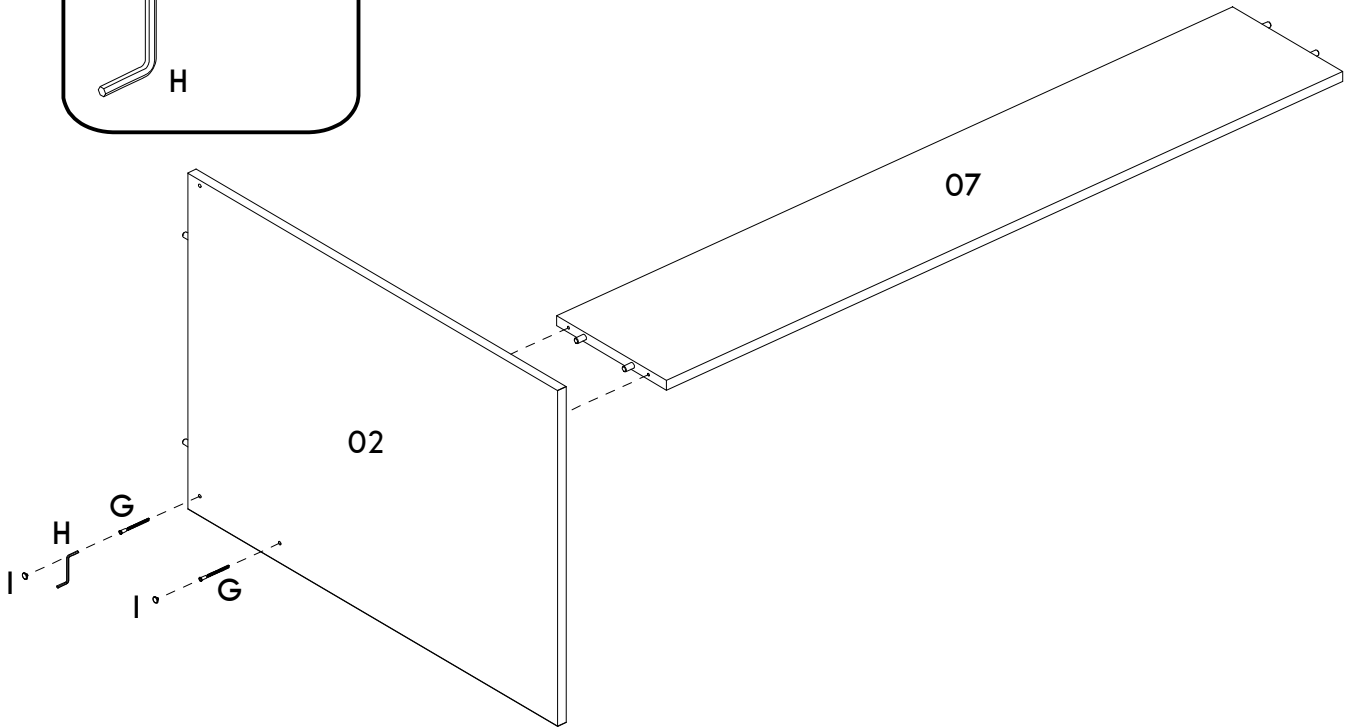
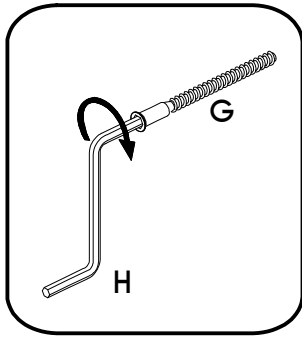

05

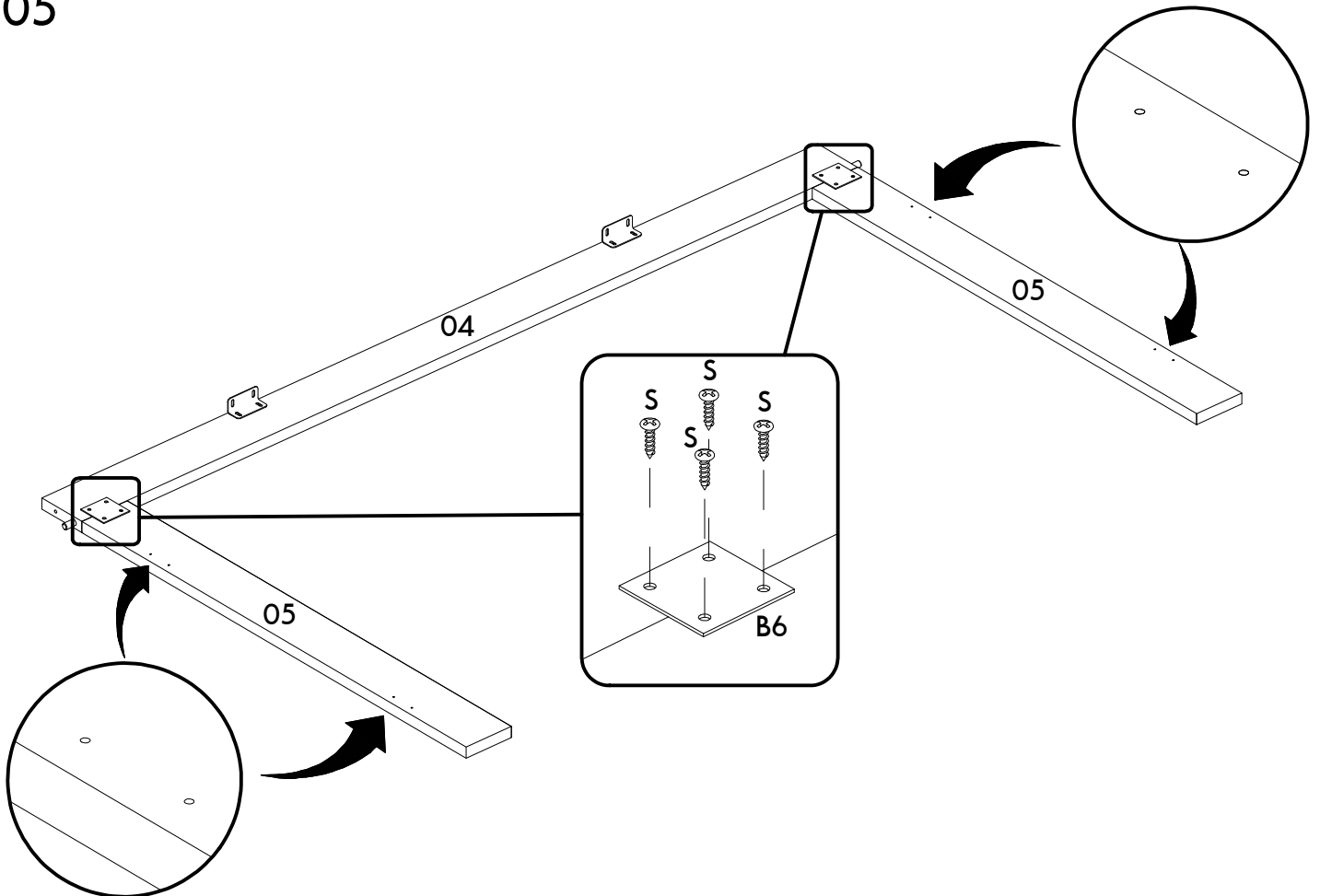

06

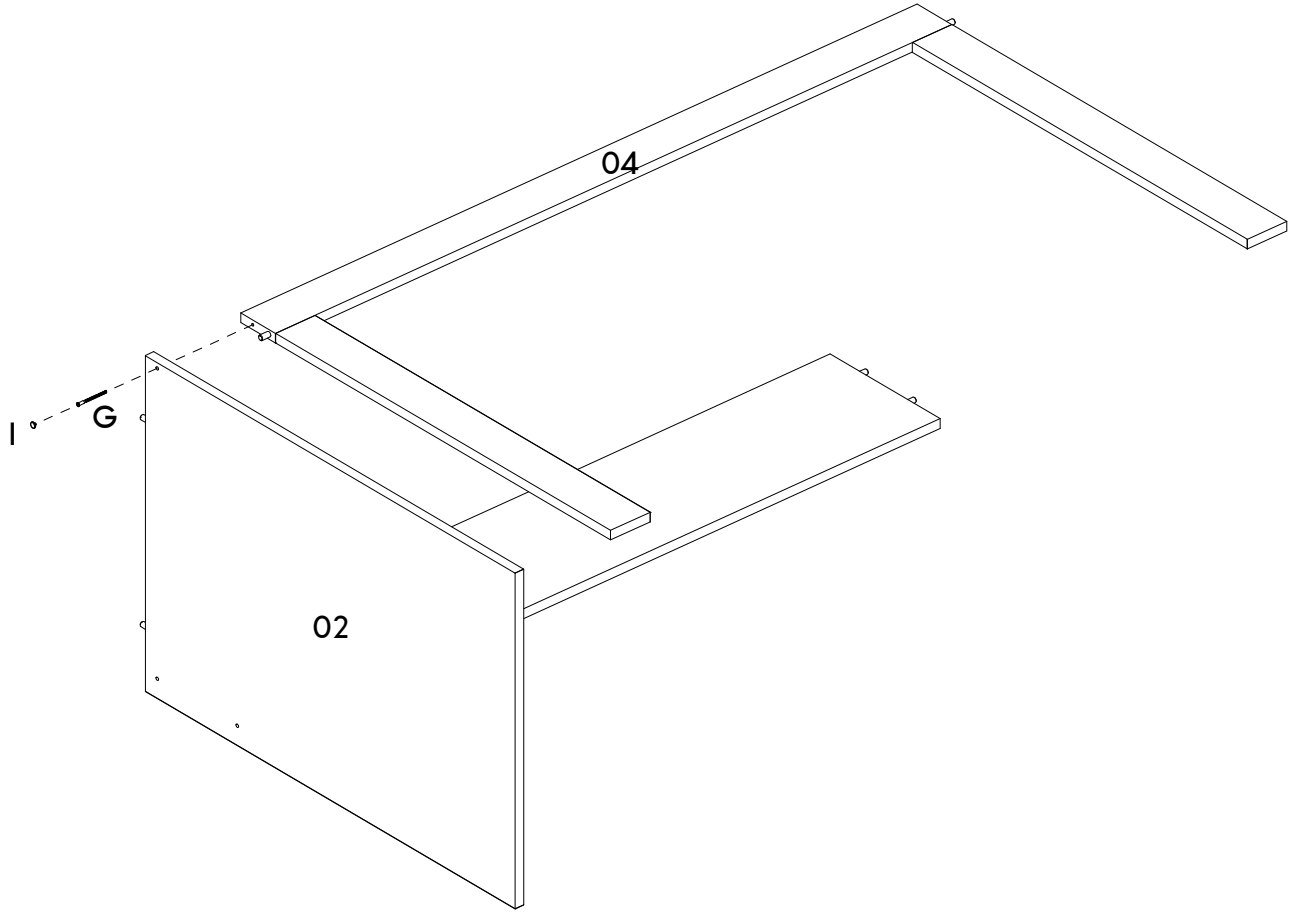

07

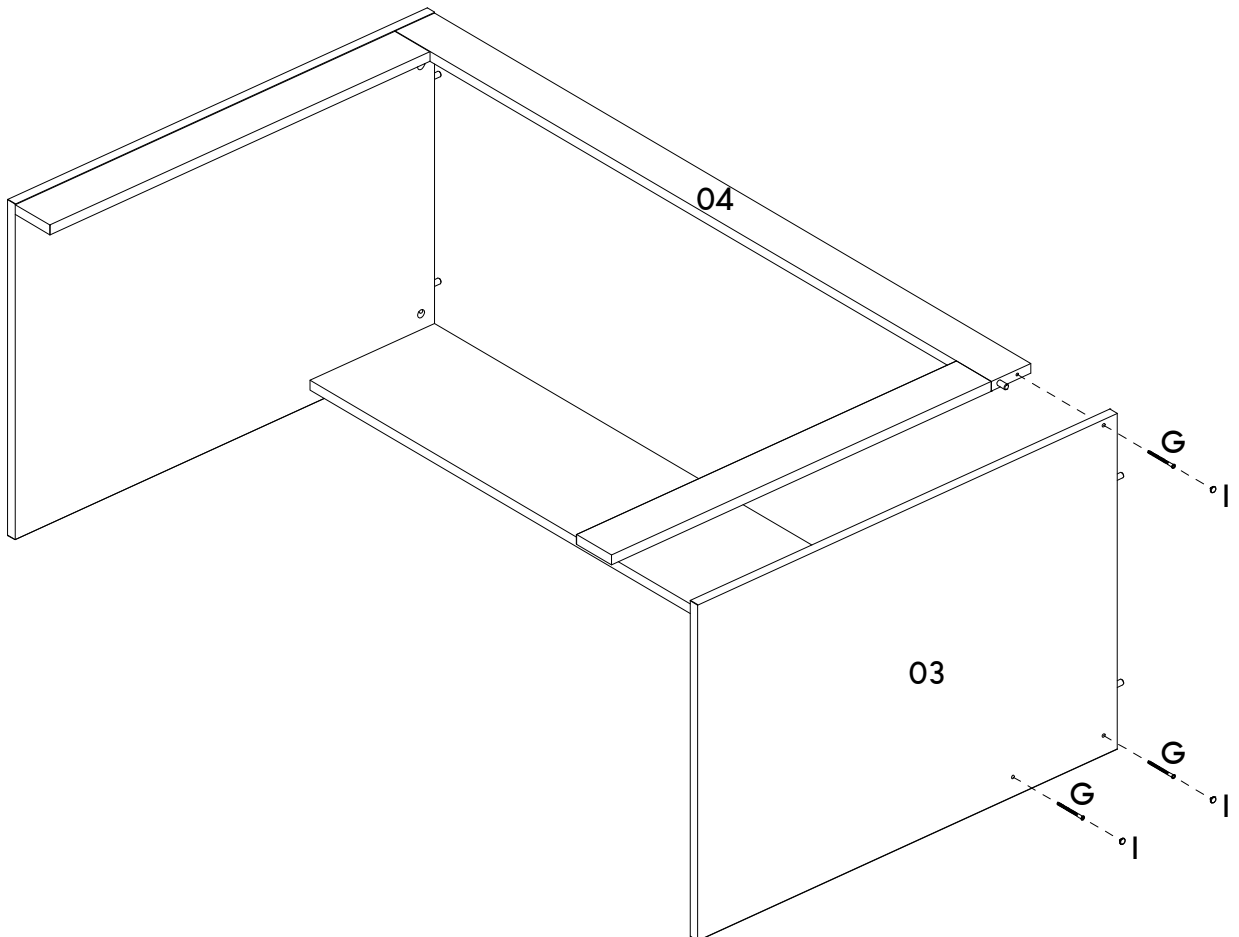

08

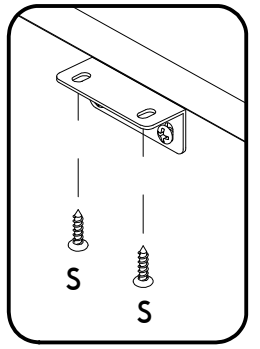
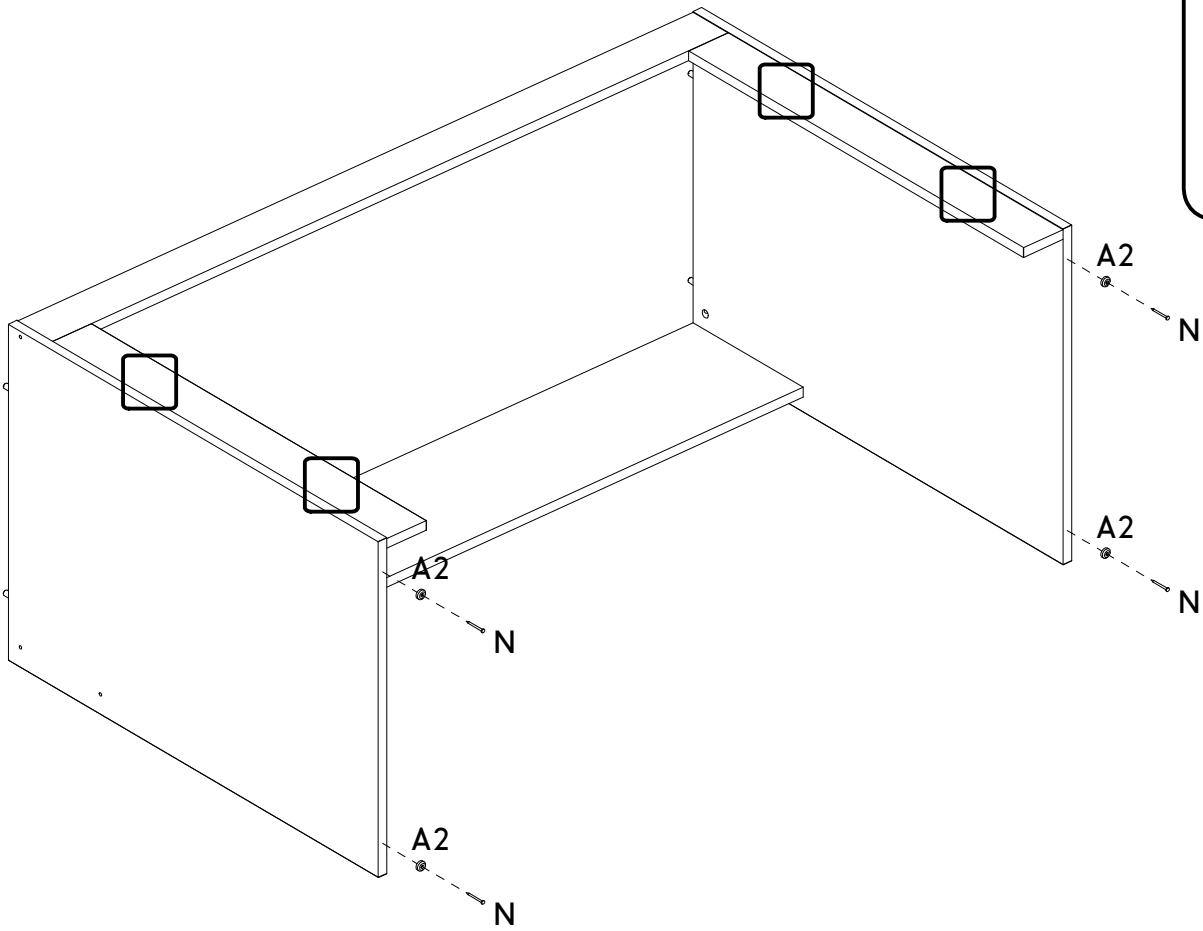

09

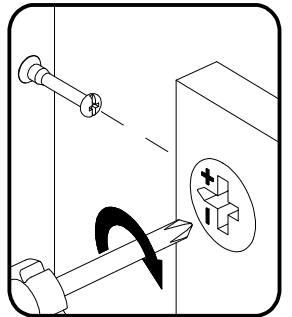
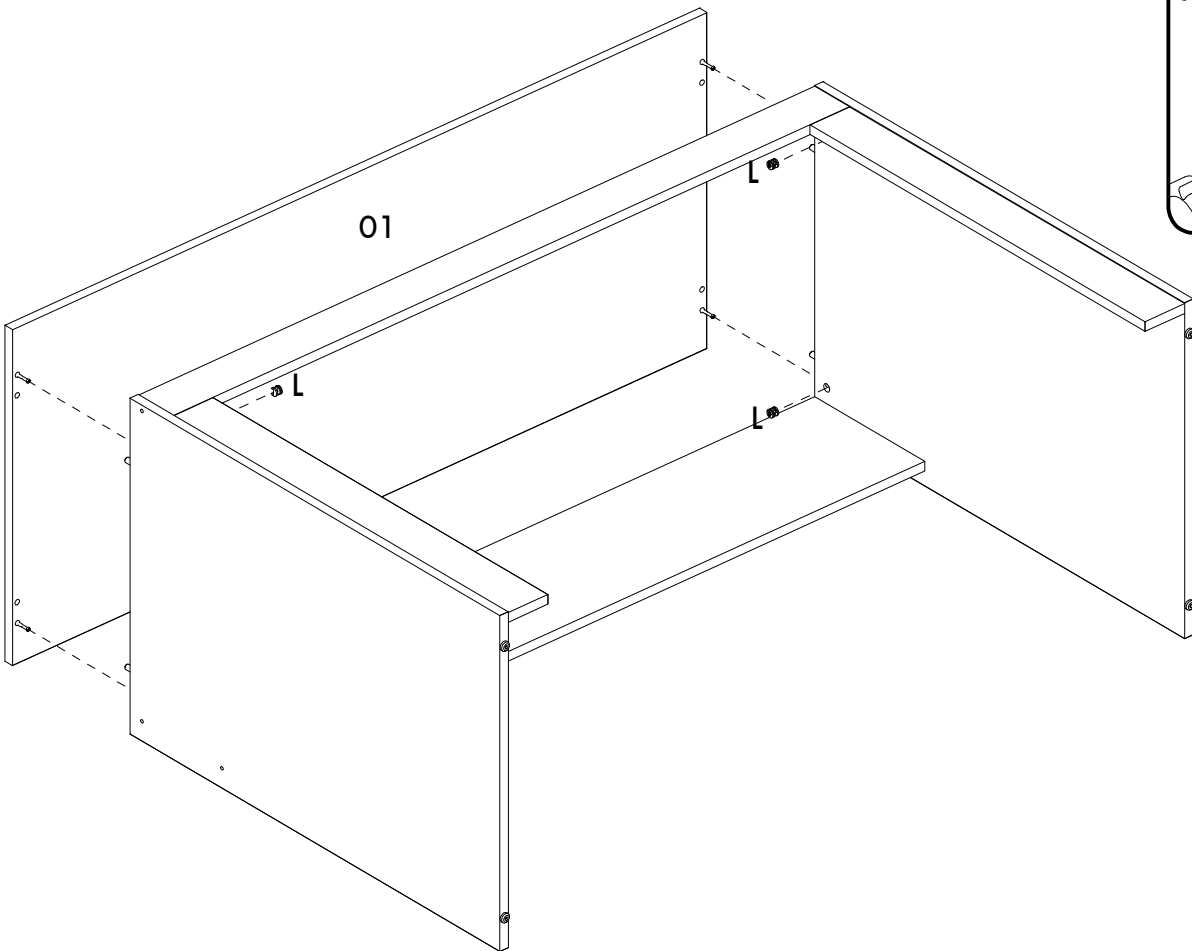

10

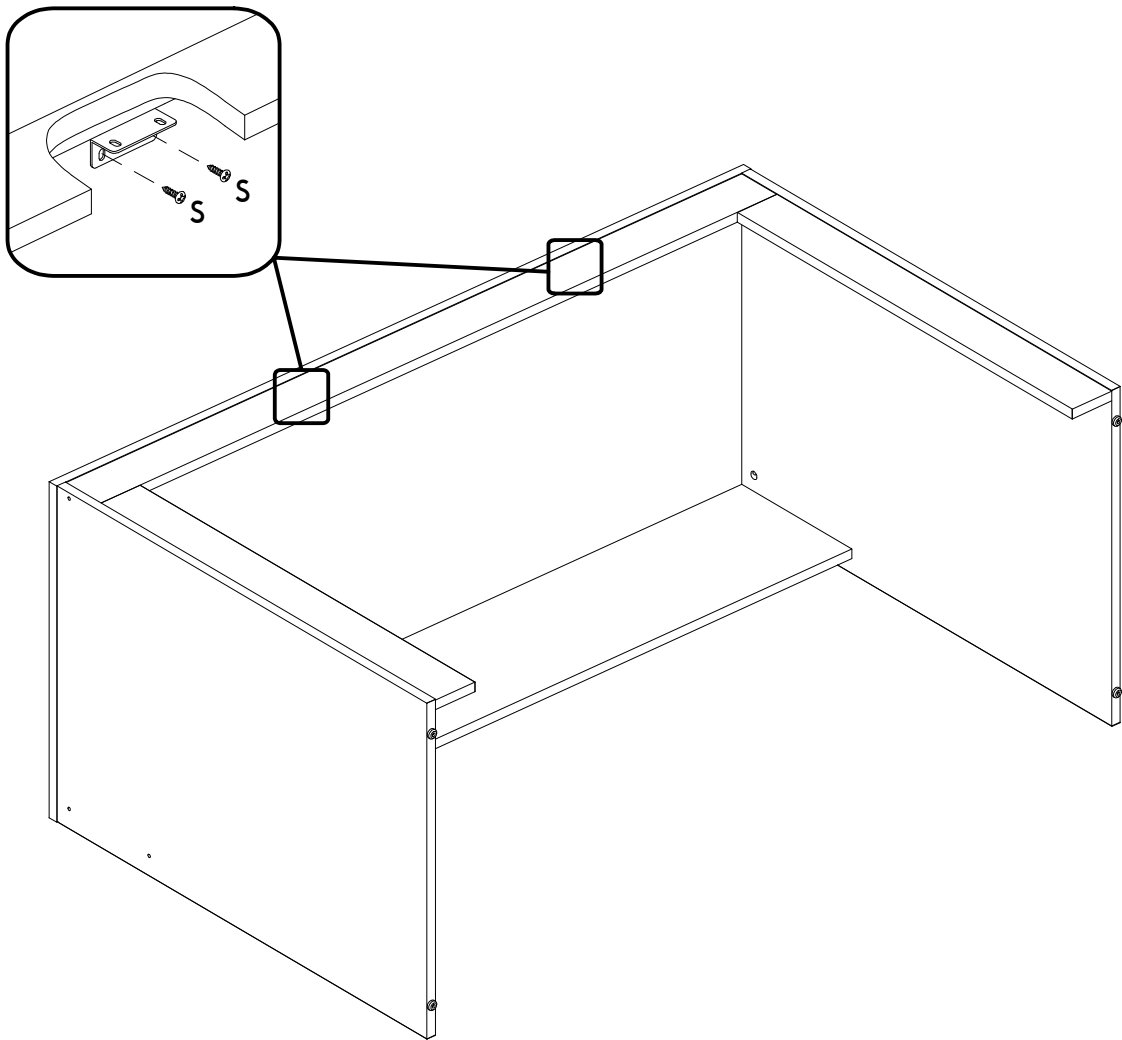

PESO MÁXIMO RECOMENDADO SENDO ESTE DISTRIBUIDO UNIFORMEMENTE  
MAXIMUM RECOMMENDED WEIGHT BEING THIS EVENLY DISTRIBUTED / PESO MÁXIMO RECOMENDADO SIENDO ESTE UNIFORMEMENTE DISTRIBUIDO

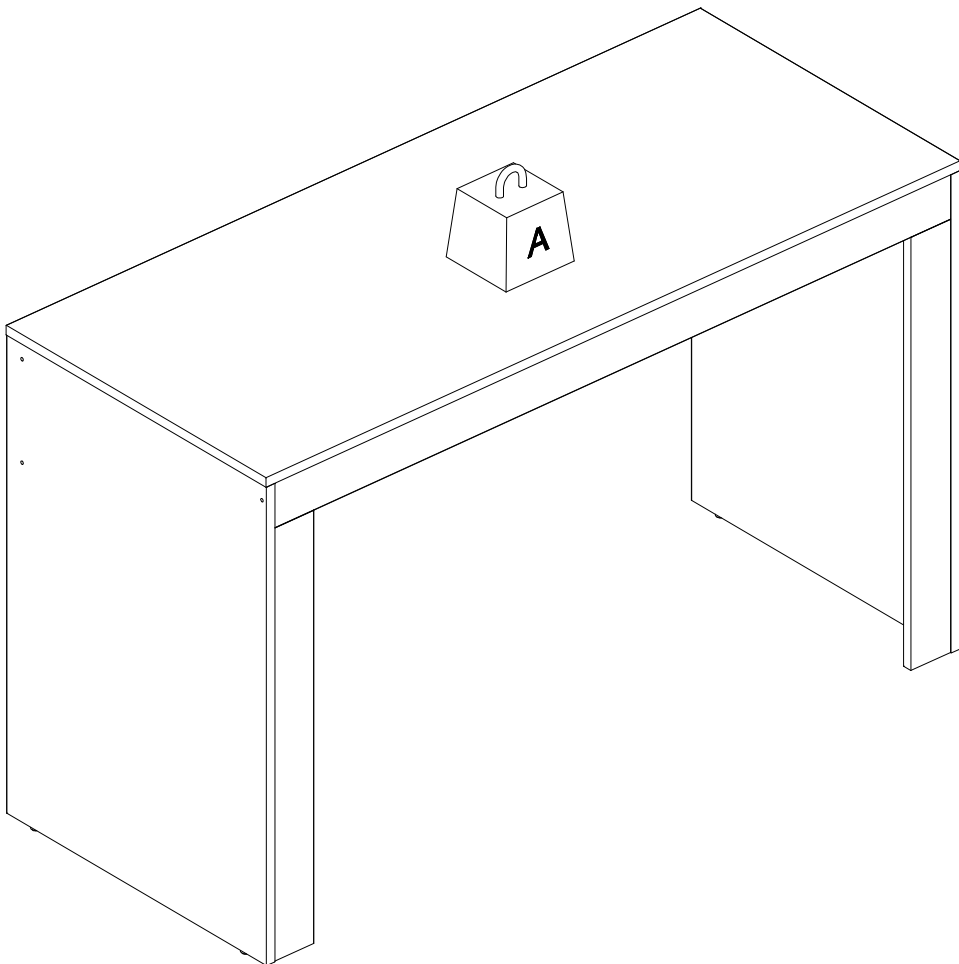

	KG	LB
A	25	55