

Frontal

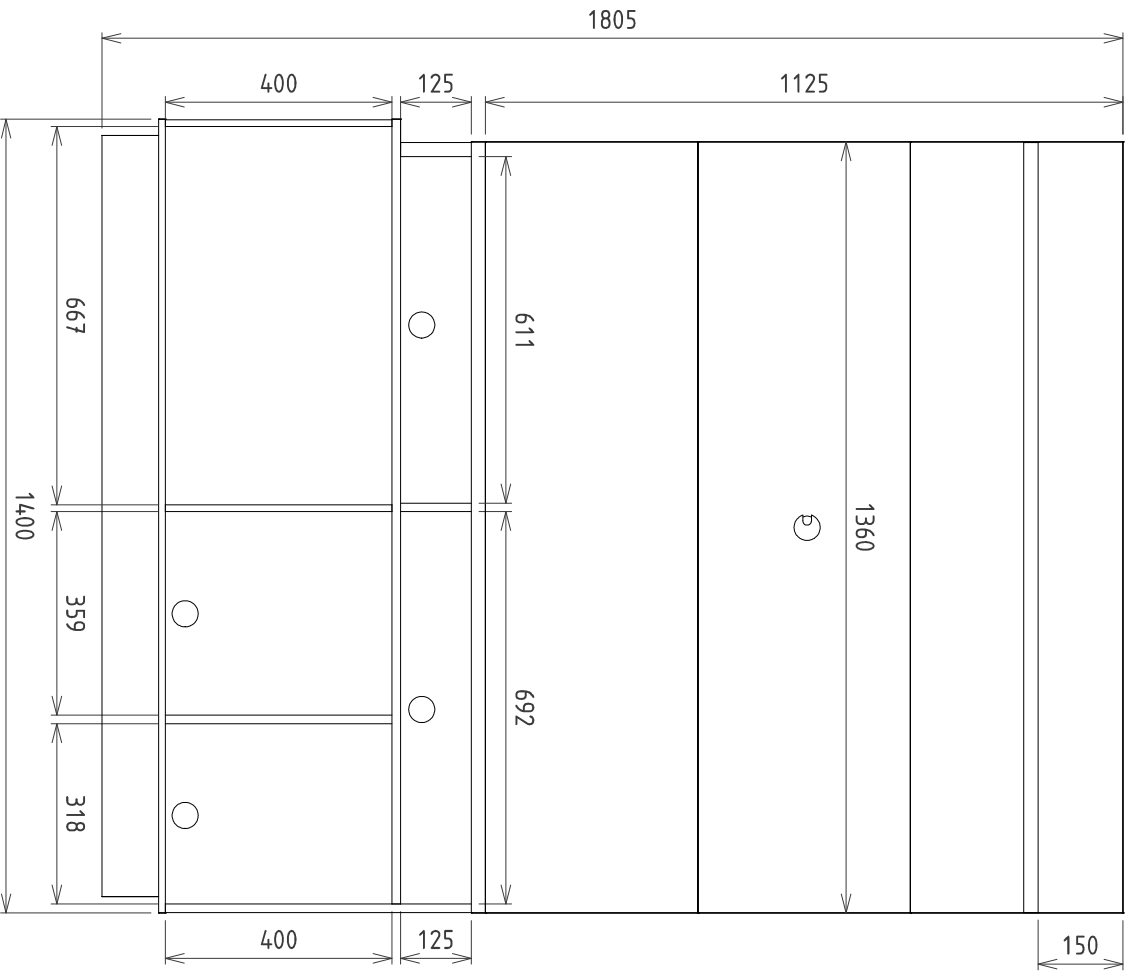

Perspectiva

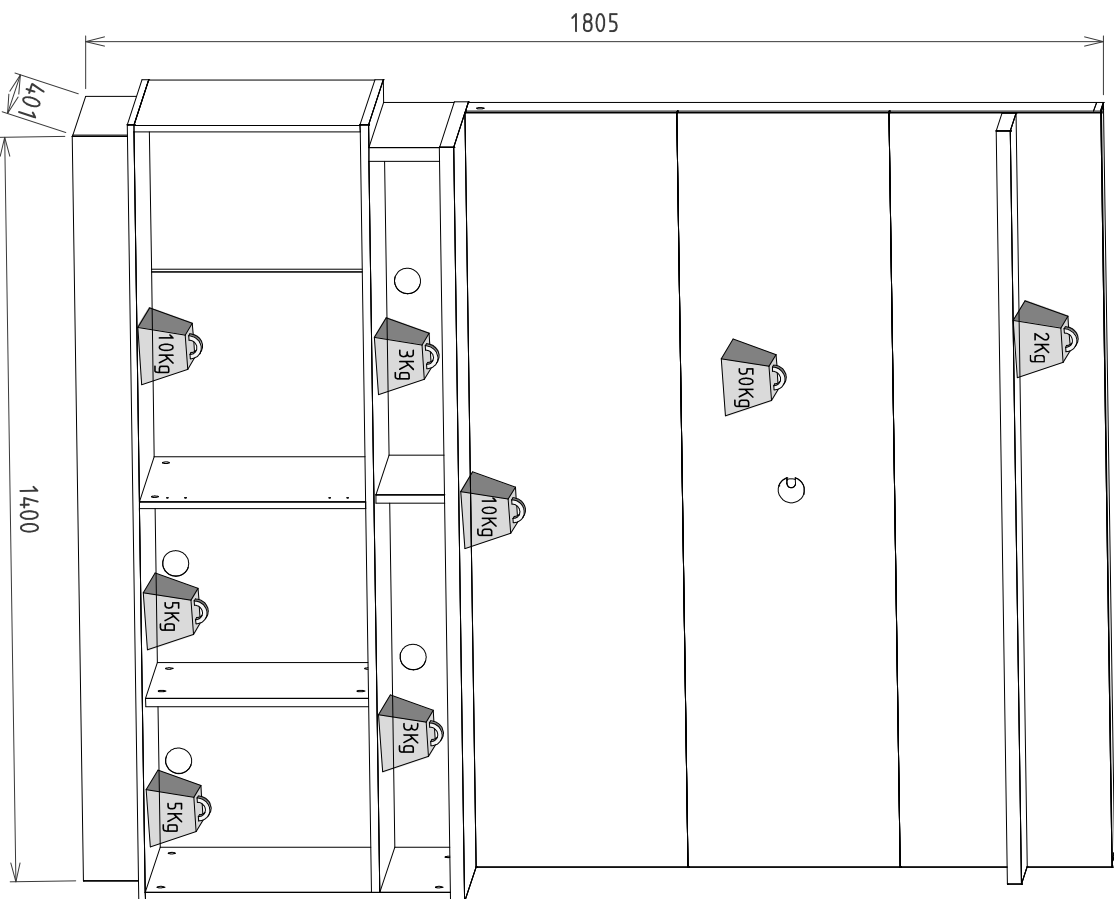

Linha: Sala
 Mod.: Home
 Cód.: 2.620

 Canal do Montador
 Acesso e Participa!

 ESQUEMA DE MONTAGEM
 ASSEMBLY INSTRUCTIONS
 ESQUEMA DE MONTAJE

 Obs: Usar caixa de embalagem para forrar o chão na hora da montagem.
 Note: Use the packing box to cover the floor at the time of assembly.
 Nota: Utilice la caja de embalaje para cubrir el suelo en el momento del montaje.

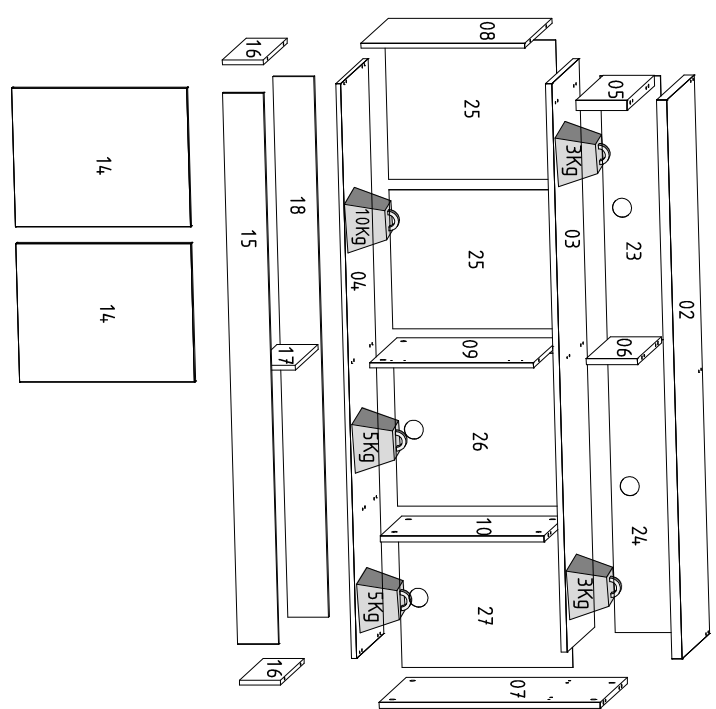
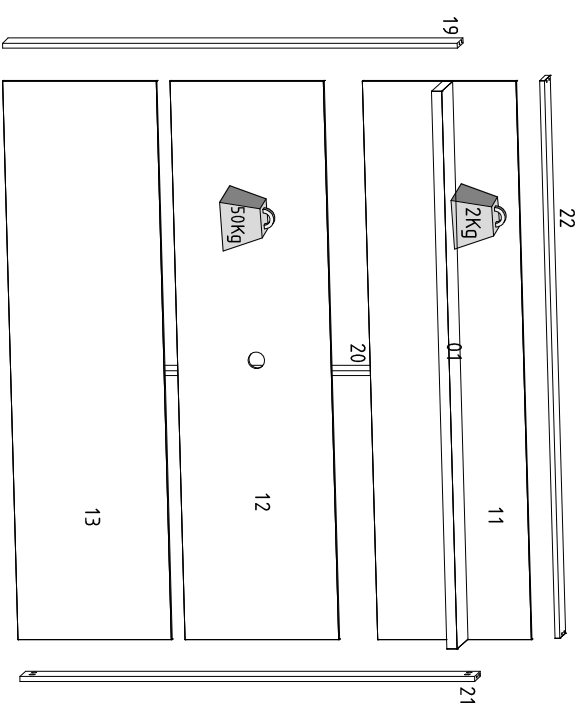
 COLIBRI - IND. COM. DE MÓVEIS LTDA.
 Rua Rouxinol, 5530 - Fone/Fax (43) 3275 - 8600
 Pq. Industrial XI - CEP 86.706-410 - Araucarias - PR
 E-mail: sac@colibrimoveis.com.br
 Site: www.colibrimoveis.com.br

Cód.	Referência	Cor Canela R./Off W.	Pegças	Qt.	Medidas	M.P.	Piece	Pieza
01	2620A0.001	690	Prateleira Superior	1	1358x150x25	MDP	Top shelf	Estante mayor
02	2620A0.002	460	Tampo	1	1360x385x25	MDP	Cover	Cubierta
03	2620A0.003	690	Prateleira DVD	1	1384x383x15	MDP	Shelf DVD	Estante DVD
04	2620A0.004	690	Base	1	1400x383x12	MDP	Base	Base
05	2620A0.005	460	Lateral esq DVD	1	383x125x25	MDP	Left side DVD	Lateral izquierdo DVD
06	2620A0.006	460	Divisão DVD	1	335x125x15	MDP	DVD room	División DVD
07	2620A0.007	460	Lateral direita	1	540x383x15	MDP	Right side	Lateral derecho
08	2620A0.008	690	Lateral esquerda	1	400x383x12	MDP	Left side	Lateral izquierdo
09	2620A0.009	690	Divisão esquerda	1	400x383x12	MDP	left division	División izquierda
10	2620A0.010	690	Divisão direita	1	400x305x15	MDP	Right division	División derecha
11	2620A0.011	460	Painel Superior	1	1360x375x12	MDP	Top panel	Panel mayor
12	2620A0.012	460	Painel central	1	1360x375x12	MDP	Bottom panel	Panel central
13	2620A0.013	460	Painel inferior	1	1360x375x12	MDP	Bottom panel	Panel por debajo
14	2620A0.014	690	Porta	2	427x337x15	MDP	Door	Puerta
15	2620A0.015	460	Rodapé frontal	1	1342x100x12	MDP	Front footer	Pie de página frontal
16	2620A0.016	460	Rodapé lateral	2	335x100x12	MDP	Side skirting	Pie de página lateral
17	2620A0.017	99	Rodapé central	1	322x100x12	MDP	Central footer	Pie de página central
18	2620A0.018	99	Rodapé traseiro	1	1316x100x12	MDP	Rear skirting	pie de página trasero
19	2620A0.019	460	Travessa lat esq	1	1111x80x12	MDP	Left side cross member	Travesaño izquierdo
20	2620A0.020	99	Travessa central	1	1111x80x12	MDP	Central beam	Travesaño central
21	2620A0.021	460	Travessa lat dir	1	1111x80x12	MDP	Ride side crossbar	Travesaño derecho
22	2620A0.022	460	Travessa superior	1	1358x80x12	MDP	Upper beam	Travesaño mayor
23	2620A0.023	460	Fundo sup esq	1	642x147x3	HDF	Top left background	Fondo mayor izquierdo
24	2620A0.024	460	Fundo sup dir	1	713x147x3	HDF	Top right bottom	Fondo mayor derecho
25	2620A0.025	460	Fundo inf esq	2	417x338x3	HDF	Bottom left	Fondo por debajo izquierdo
26	2620A0.026	460	Fundo inf central	2	417x372x3	HDF	Bottom bottom center	Fondo por debajo central
27	2620A0.027	460	Fundo inf dir	1	417x338x3	HDF	Lower right bottom	Fondo por debajo derecho

Para pedidos de Assistência Técnica agrupar a referência da Peça com o nº da Cor. Ex: 2620A0.001.690 (Prateleira Sup. na cor Off W.)

A	B	C	D	E	F
Parafuso 3,5 x 12 / Serrvo 3,5 x 12 / Tornillo 3,5 x 12 - 176	Parafuso 4,0 x 50 / Serrvo 4,0 x 50 / Tornillo 4,0 x 50 - 12	Parafuso 4,5 x 60mm / Serrvo 4,5 x 60mm / Tornillo 4,5 x 60mm - 09	Porca cilíndrica / Cylindrical nut / Tuercas cilíndricas - 18	Cavilha 6 x 30 / Dowel Pin 6 x 30 - 34	Tornillo maior / Lid / Dornschrauben - 20/14/14
Dobradiça curva 28 mm / Hinge curve 28 mm / Cervo de bisagra 28mm - 04	Cabo 5mm color / Slim slim color / Cables slim bisagra - 04	Chapeta reta 4 furos / Straight plate 4 holes / Placa reta 4 aberturas - 08	Junção de furos / Connection of holes - 22	Passa fio 40mm / Pass wire 40mm / Falso cable 40mm - 01	Suporta 1 / Support / Soporte 1 - 06
Prego 8 x 8 / Nail 8 x 8 / Clavo 8 x 8 - 62	Perfil "H" - 400mm / Profile "H" - 400mm / Perfil "H" - 01	Cantoneiras 2 furos / Corners 2 holes / Esquinas 2 agujeros - 04	Cantoneiras 4 furos / Agiles 4 holes / Angulos 4 agujeros - 30		

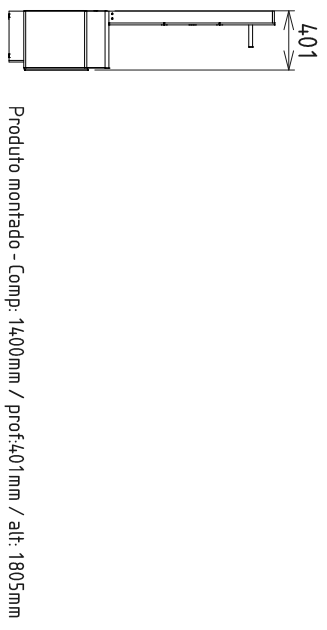
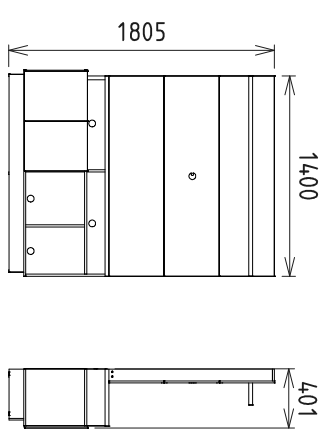

Produto montado - Comp: 1400mm / prof: 401mm / alt: 1805mm

ETAPAS DA MONTAGEM / STAGES OF THE ASSEMBLY / ETAPAS DE LA ASAMBLEA

Para uma montagem perfeita do produto, siga a sequência:

For a perfect assembly of the product, it follows the sequence / Para un montaje perfecto del producto, sigue el secuencia

Passo 01

Fixação das peças 15, 16, 17 e 18

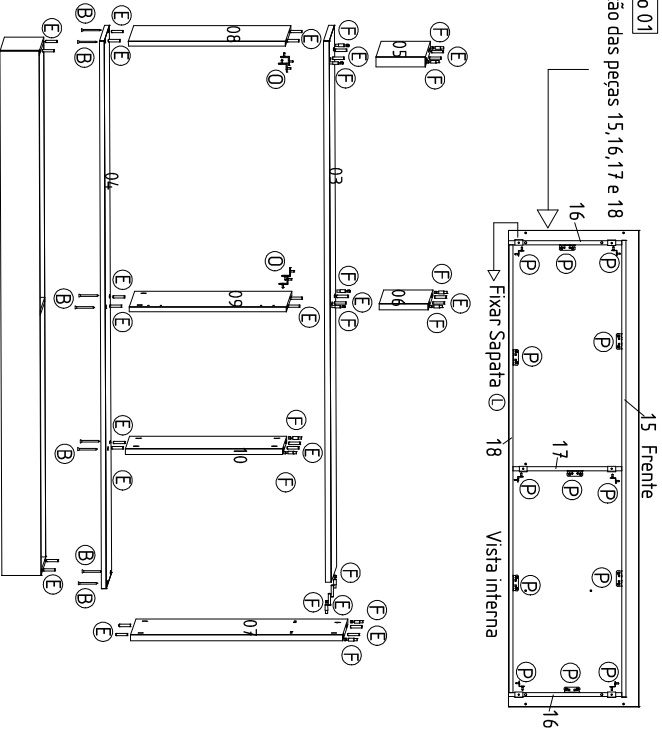

Passo 02

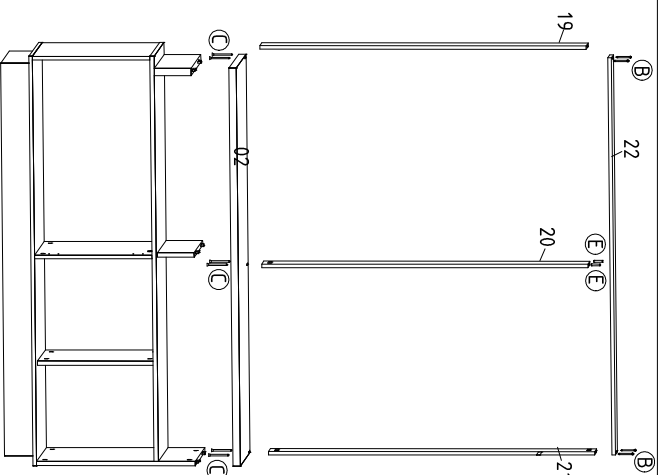

Passo 03

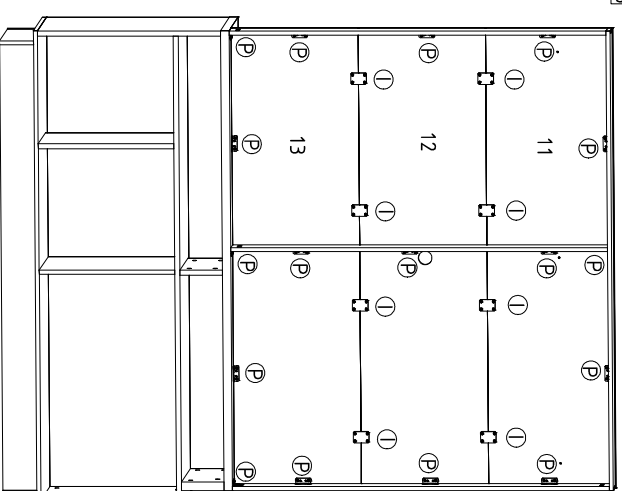

Passo 04

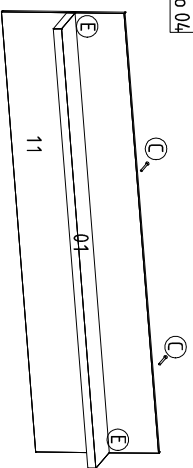

Vista traseira

Passo 05

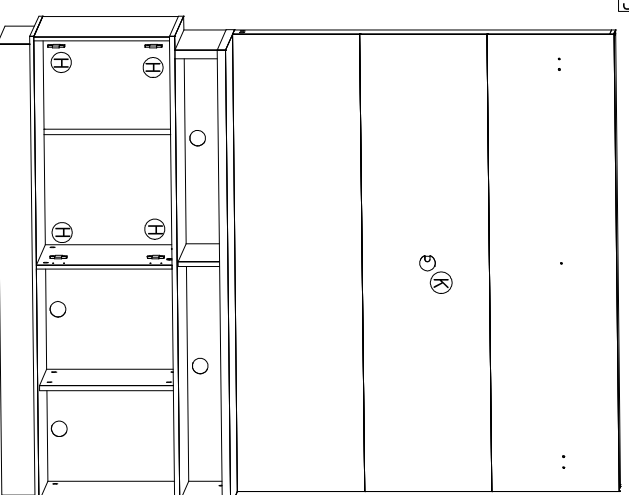

G K

