



ESQUEMA DE MONTAGEM  
ASSEMBLY INSTRUCTIONS  
ESQUEMA DE MONTAJE

Obs: Usar caixa de embalagem para ferrar o chão na hora da montagem.  
Note: Use the packing box to cover the floor at the time of assembly.  
Nota: Utilice la caja de embalaje para cubrir el suelo en el momento del montaje

COLIBRI - IND. COM. DE MÓVEIS LTDA.  
Rua Rouxinol, 5530 - Fone/Fax (43) 3275 - 8600  
Pq. Industrial XI - CEP 86.706-410 - Araçuaí - PR  
E-mail: sac@colibrimoveis.com.br  
Site: www.colibrimoveis.com.br



Cód.	Referência	Cor Natureza R./Cor/W.	Pecas	Qt.	Medidas	M.P.	Piece	Pieza
01	2619A0.001	700	Prateleira maior	1	1359x107x25	MDP	Larger shelf	Estante más grande
02	2619A0.002	690	Prateleira menor	1	412x189x25	MDP	Smaller shelf	Estante pequeño
03	2619A0.003	700	Tampo	1	1800x356x25	MDP	Cover	Cubierta
04	2619A0.004	690	Prateleira DVD	1	1800x385x15	MDP	Shelf DVD	Estanteria de DVD
05	2619A0.005	690	Base	1	1800x385x15	MDP	Base	Base
06	2619A0.006	690	Lateral dir sup	1	1000x190x25	MDP	Upper right side	Lateral derecho mayor
07	2619A0.007	700	Lateral esq DVD	1	355x146x25	MDP	Left side DVD	Lateral izquierdo DVD
08	2619A0.008	700	Divisão DVD	1	336x146x15	MDP	DVD division	División DVD
09	2619A0.009	700	Lateral dir DVD	1	355x146x25	MDP	Right side DVD	Lateral derecho DVD
10	2619A0.010	690	Lateral esquerda	1	360x384x15	MDP	Left side	Lateral izquierdo
11	2619A0.011	690	Divisão	2	360x299x15	MDP	Division	División
12	2619A0.012	690	Divisão central	1	360x336x12	MDP	Central division	División central
13	2619A0.013	690	Lateral direita	1	360x384x15	MDP	Right side	Lateral derecho
14	2619A0.014	690	Porta	1	920x392x15	MDP	Door	Puerta
15	2619A0.015	700	Painel superior	1	1360x385x12	MDP	Top panel	Panel mayor
16	2619A0.016	700	Painel central	1	1360x385x12	MDP	Central panel	Panel central
17	2619A0.017	700	Painel inferior	1	1360x385x12	MDP	Bottom panel	Panel por debajo
18	2619A0.018	690	Painel menor	1	436x152x12	MDP	Lower panel	Panel pequeño
19	2619A0.019	700	Travessa esquerda	1	1153x70x12	MDP	Cross left	Travesaño izquierdo
20	2619A0.020	700	Travessa superior	1	1331x70x12	MDP	Cross higher	Travesaño mayor
21	2619A0.021	700	Travessa direita	1	1153x70x12	MDP	Cross right	Travesaño derecha
22	2619A0.022	99	Travessa central	1	1140x70x12	MDP	Cross central	Travesaño central
23	2619A0.023	700	Rodapé frontal	1	1798x100x12	MDP	Front footer	Pie de página frontal
24	2619A0.024	99	Rodapé trasero	1	1772x100x12	MDP	Rear skirting	Pie de página trasero
25	2619A0.025	700	Rodapé lateral	2	336x100x12	MDP	Side skirting	Pie de página lateral
26	2619A0.026	99	Rodapé central	2	324x100x12	MDP	Central footer	Pie de página central
27	2619A0.027	690	Fundo superior	1	1010x437x3	HDF	Top backround	Fondo mayor
28	2619A0.028	700	Fundo central	1	1766x164x3	HDF	Central fund	Fondo central
29	2619A0.029	690	Fundo inferior	2	894x377x3	HDF	Bottom higher	Fondo por debajo

Para pedidos de Assistência técnica, agrupar a Referência da Peça com o nº da Cor. Ex:2619A0.001.700 (Prateleira maior na cor Nature R)

A	B	C	D	E	F
Parafuso 3,5 x 12 / Screw 3.5 x 12 / Tornillo 3,5 x 12 - 200	Parafuso 4,0 x 50 / Screw 4.0 x 50 - 13	Parafuso 5,0 x 50mm / Screw 5.0 x 50mm / Tornillo 5,0 x 50mm - 04	Chaveta 6 x 30 / Dowel Pin 6 x 30 / Cavete 6 x 30 - 54	Porca cilíndrica Cylindrical nut / Tuerca cilíndrica - 13	Trav. Lateral pino Lateral Pin / Trav. Lateral pino Tape:Trav.lateral pino -35/24/22
Passa fio 40mm Pass wire 40mm Zassal cable 40mm - 01	Contorneta 4 furos Agile 4 holes Anillo 4 agujeros - 37	Chaveira reta 4 furos Straight plate 4 holes Placa recta 4 agujeros - 09	Junção de furos / Junction of furs / Conexión de furos - 15	Preço 8 x 8 / Nail 8 x 8 / Clavo 8 x 8 - 77	Suporte "U" Support stair / Support estera - 08
Protetor de vidro Glass shield Repaça de vidro - 02	Luminária Luminaria - 01	Suporte "L" Zapeta "L" - 08	Centro fecho Against closure Centra el cierre - 02	Kit porta de correr KIT Sliding door Kit puerta corredera - 01	Trava superior plástico Plastic superior Reb. superior plástico - 02
cantoneiras 2 luros Corner 2 roses Cantoneira 4,5 x 60 / Tornillo 4,5 x 60 - 03					
Escuna 2 apoios - 02					

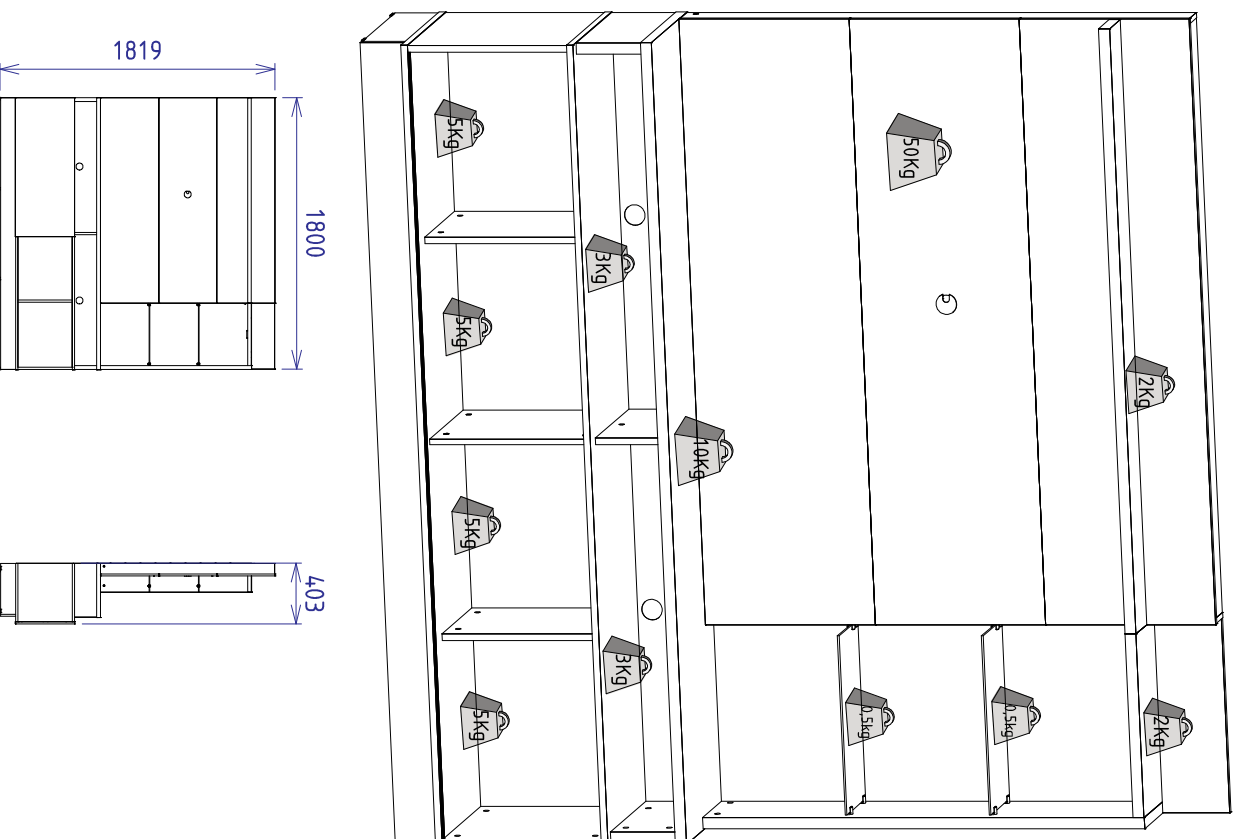

# ETAPAS DA MONTAGEM / STAGES OF THE ASSEMBLY / ETAPAS DE LA ASAMBLEA

**Passo 01** Neste passo montar produto detriado.

**Para uma montagem perfeita do produto, siga a sequencia:**

For a perfect assembly of the product, it follows the sequence / Para un montaje perfecto del producto, sigue el sequencia

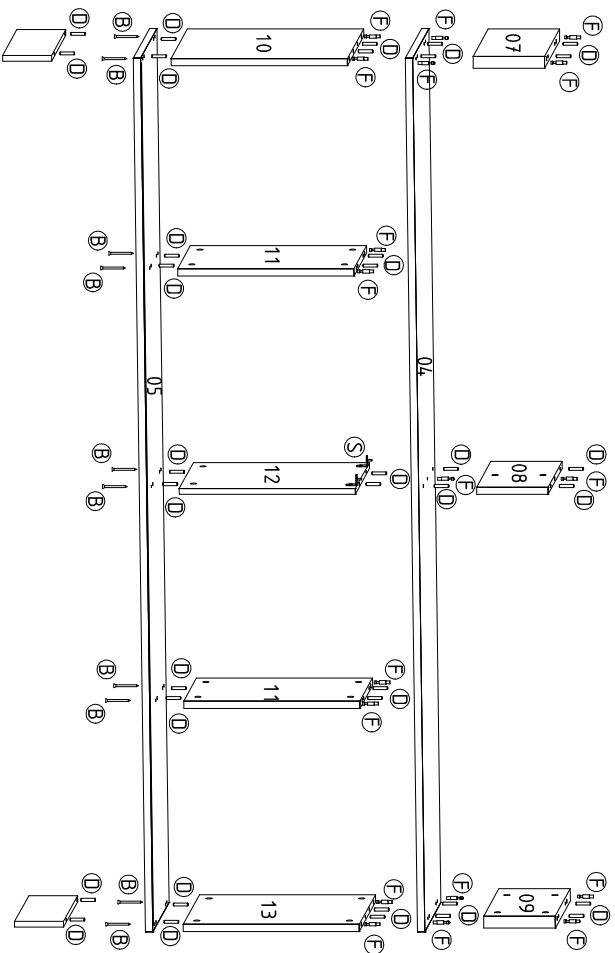

**Passo 02**

Fixação das peças  
23,24,25 e 26

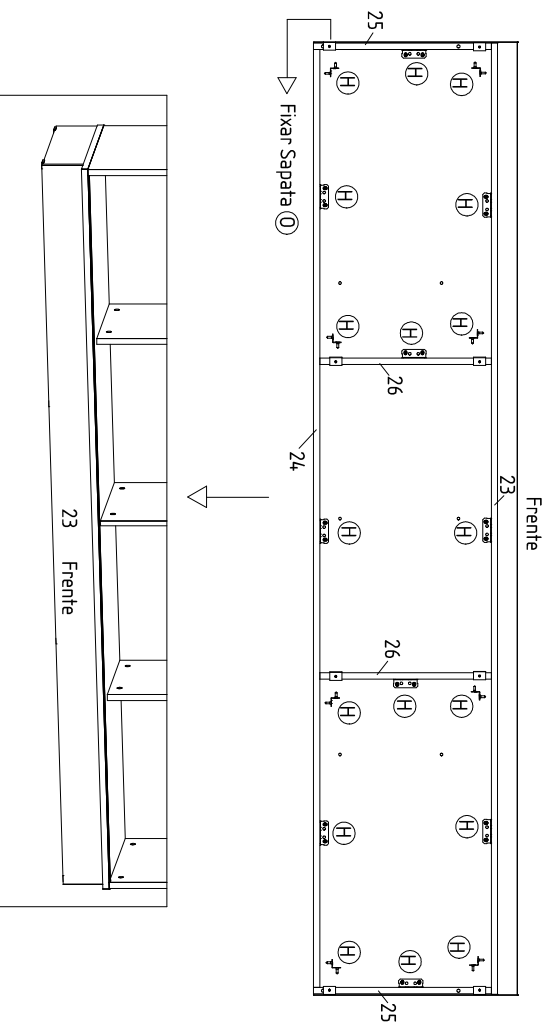

**Passo 03**

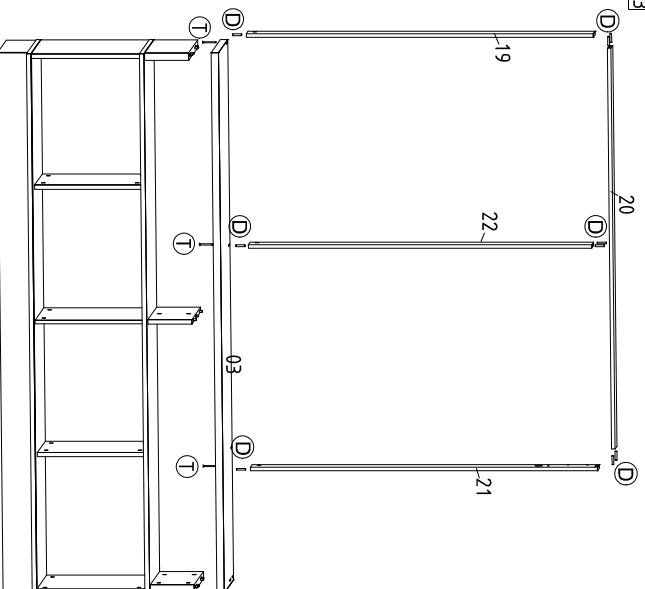

**Passo 04**

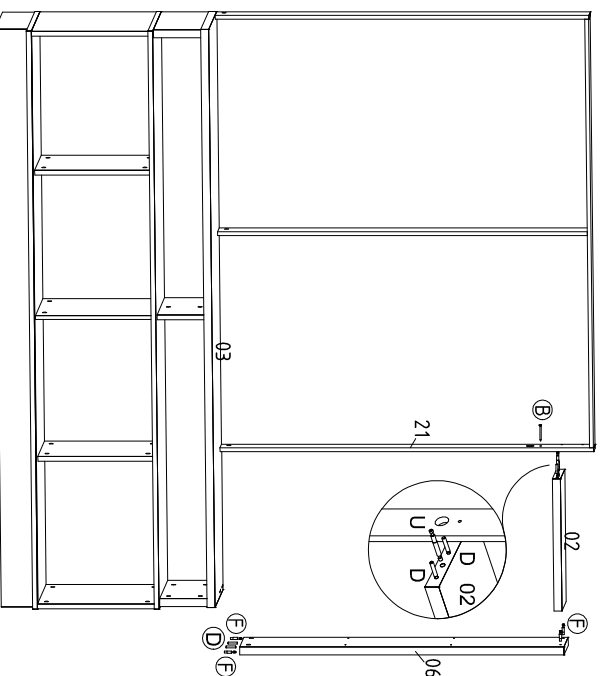

**Passo 05**

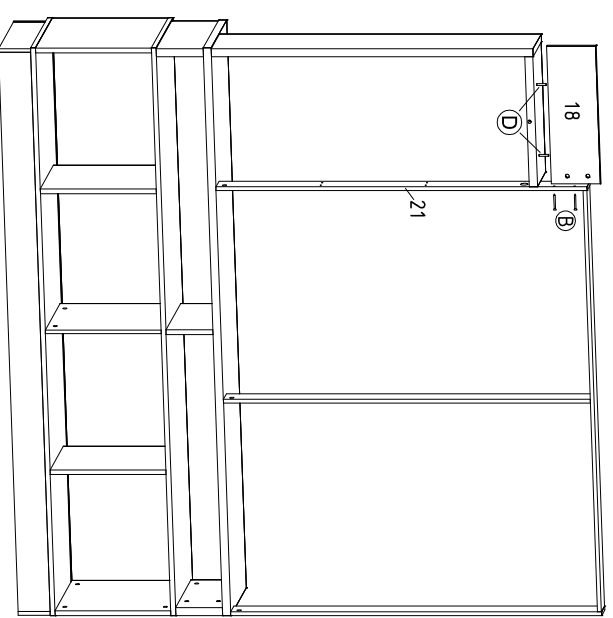

# ETAPAS DA MONTAGEM / STAGES OF THE ASSEMBLY / ETAPAS DE LA ASAMBLEA

## Para uma montagem perfeita do produto, siga a sequência:

For a perfect assembly of the product, it follows the sequence / Para un montaje perfecto del producto, sigue el secuencia

