

MANUAL COMPLETO COMPLETE MANUAL



DEMARTÊZ

mobília

DEMÓBILE Indústria de Móveis Ltda.
Rua : Jurutau, 1350 - Pq. Industrial II.
Cep.: 86703-070
Arapongas - PR - Brasil
demobile@demobile.com.br

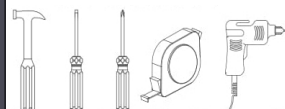

Avisos

1. Ler atentamente as instruções do manual antes de iniciar a montagem do móvel.
2. A montagem deverá ser feita em superfície limpa e plana, aconselhamos forrar o chão com a embalagem do produto, para não danificar.
3. Os parafusos devem ser apertados periodicamente.
4. Evitar batidas e contato com objetos cortantes.
5. O peso máximo de carga informado refere-se a objetos distribuídos de maneira uniforme sobre toda área de contato da peça.

Limpeza e Conservação

Efetuar a limpeza somente com pano macio limpo e seco.
Não Utilizar produtos abrasivos ou químicos.

Garantia

1. O fabricante responsabiliza-se apenas pelas peças do produto.
2. A montagem incorreta acarretará na perda da garantia e das assistências, desta forma o produto deverá ser montado por profissional qualificado.
3. Não estão cobertos pela garantia problemas que tenham origem na utilização inadequada do produto ou na exposição do mesmo a intempéries como: infiltrações, infestação de pragas em geral, aparecimento de mofo e outros, decorrentes do ambiente de instalação.

Assistência Técnica: Em caso de peças em assistência técnica é necessário que as mesmas sejam solicitadas junto a loja ou site no qual a compra do produto foi realizada

Warnings

1. Read the manual instructions carefully before starting to assemble the furniture.
2. The assembly must be done in clean and flat surface, we advise to put the product packaging on the floor, not to damage it during the assembling.
3. The screws must be tightened periodically.
4. Avoid hitting and contacting sharp objects.
5. The payload informed refers to the objects distributed all over the piece contact area.

Cleaning and conservation

Clean the product just with a soft, cleaned and dry cloth.
Do not use abrasive or chemicals products.

Warranty

1. The manufacturer is only responsible for product parts.
2. Incorrect assembling will make you lost the guarantee and assistance, in this way the product must be assembled by qualified professional.
3. It is Not covered by the warranty problems caused by an inappropriate use of the product or product exposure even in bad weather, such as: infiltrations, pest infestation in general, appearance of mold and others, caused by the installation environment.

Technical Assistance: Damaged pieces! Ask on the stores you bought it.

Advertencias

1. Lee atentamente las instrucciones del manual antes de empezar a armar los muebles.
2. El montaje debe hacerse en superficie limpia y plana, utilice el empaque del Producto para cubrir el piso
3. Los tornillos deben ser apretados periódicamente
4. Evite golpear y chocar objetos punzantes
5. El peso máximo de carga tiene relación a los objetos distribuydos sobre toda el área de contacto de la pieza.

Limpeza y conservación

Limpiar solo con un trapo suave, limpio y seco
No utilice productos abrasivos o productos químicos

Garantía

1. El fabricante solo es responsable a las partes del producto.
2. Armar incorrectamente supone la pérdida de garantía y repuestos, de esta manera el producto debe ser ensamblado por profesional calificado
3. No es garantizado problemas derivados del uso inapropiado del producto, o exposición del producto al mal tiempo, como: infiltraciones, infestación de plagas en general, aparición de moho y otros.

Asistencia técnica: en caso de piezas rotas es necesario que sea solicitadas las mismas a la tienda o sitio web donde se compró el producto.

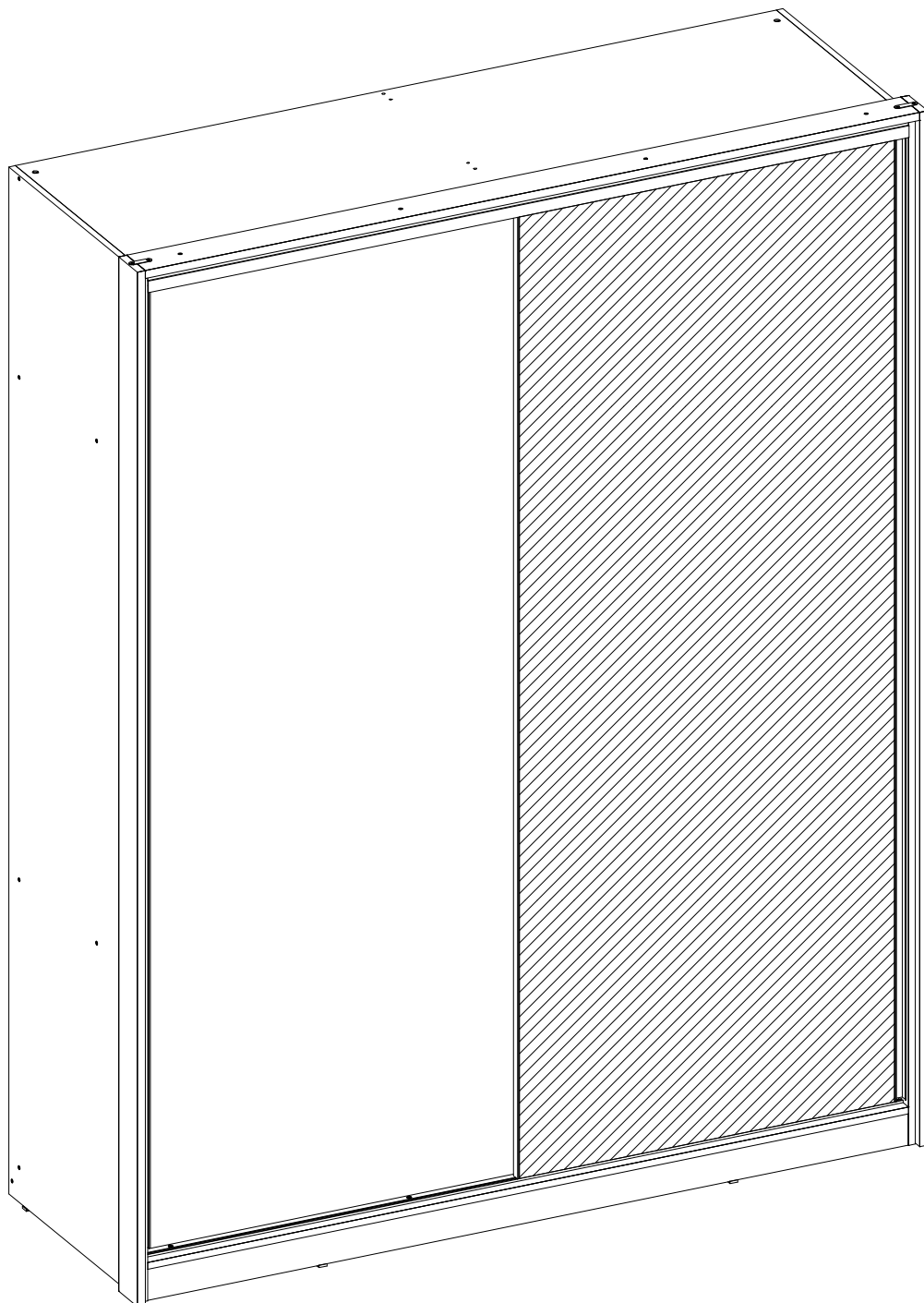

D23010 GUARDA ROUPA CASAL 02 PORTAS CORRER 03 GAVETAS EPICO

D23010 WARDROBE 02 DOORS 03 DRAWERS EPICO

D23010 CLOSET MATRIMONIAL 02 PUERTAS 03 CAJONES EPICO

D23010

GUARDA ROUPA CASAL 02 PORTAS CORRER 03 GAVETAS EPICO
 WARDROBE 02 DOORS 03 DRAWERS EPICO
 CLOSET MATRIMONIAL 02 PUERTAS 03 CAJONES EPICO

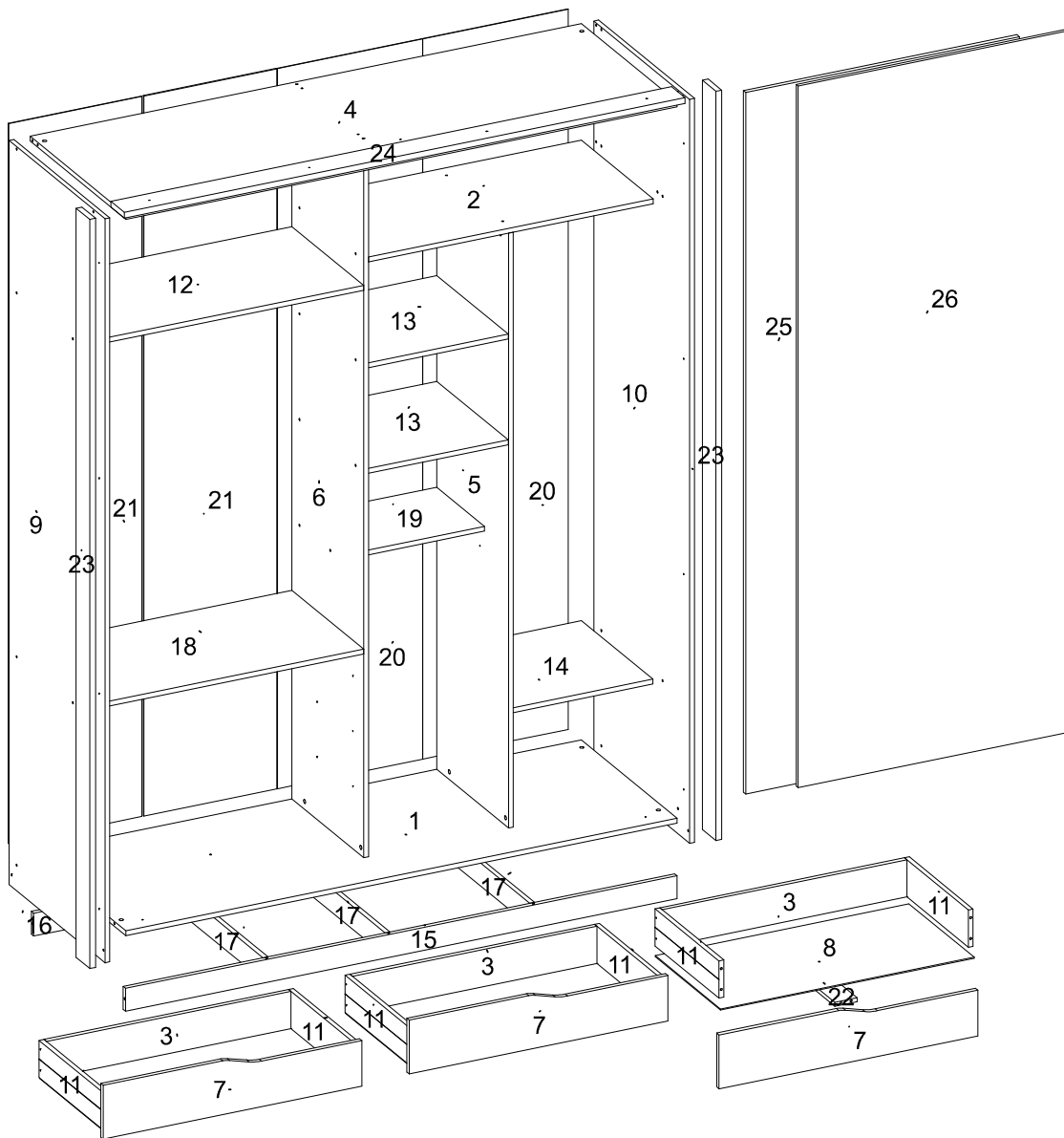

SEQ.	CODIGO	AMENDOLA TOUCH	REF_01	REF_02	REF_03	REF_04	REF_05	REF_06	REF_07	DESCRICAÇÃO DE PECAS DESCRIPTION OF PARTS DESCRIPCION DE LAS PIEZAS	DATA LANCAMENTO: DATA ATUALIZAÇÃO:	09/11/2021 11/11/2021	DIMENSÕES / QUANTIDADE DIMENSIONS / QUANTITY DIMENSIONES / CANTIDAD	QTD
1	03176	138	-	-	-	-	-	-	-	BASE	BASE	BASE	1726 X 600 X 15	1
2	04079	138	-	-	-	-	-	-	-	BASE DO MALEIRO DIREITO	SHELF	ESTANTERIA	891 X 450 X 15	1
3	06128	138	-	-	-	-	-	-	-	CONTRA FUNDO	DRAWER BACK	CONTRA FONDO	766 X 114 X 15	3
4	07134	138	-	-	-	-	-	-	-	CHAPEU	TOP PANEL	TAPA SUPERIOR DEL ROPERO	1726 X 600 X 15	1
5	08260	138	-	-	-	-	-	-	-	DIVISAO CENTRAL	RIGHT DIVISION	DIVISION DERECHA	1823 X 450 X 15	1
6	08263	138	-	-	-	-	-	-	-	DIVISAO ESQUERDA	RIGHT DIVISION	DIVISION DERECHA	2180 X 450 X 15	1
7	09173	138	-	-	-	-	-	-	-	FRENTE DE GAVETA	DRAWER FRONT	FRENTE DEL CAJON	810 X 165 X 15	3
8	10095	138	-	-	-	-	-	-	-	FUNDO GAVETA	DRAWER BASE	FONDO DEL CAJÓN	794 X 408 X 3	3
9	11335	136	-	-	-	-	-	-	-	LATERAL ESQUERDA	LEFT SIDE PANEL	LATERAL IZQUIERDA	2280 X 600 X 15	1
10	11430	136	-	-	-	-	-	-	-	LATERAL DIREITA	RIGHT SIDE PANEL	LATERAL DERECHA	2280 X 600 X 15	1
11	12022	138	-	-	-	-	-	-	-	LATERAL DE GAVETA	DRAWER SIDE	LATERAL DEL CAJON	400 X 114 X 15	6
12	15144	138	-	-	-	-	-	-	-	PRATELEIRA SUPERIOR ESQUERDA	SHELF	ESTANTERIA	820 X 450 X 15	1
13	15188	138	-	-	-	-	-	-	-	PRATELEIRA	SHELF	ESTANTERIA	448 X 438 X 15	2
14	15189	138	-	-	-	-	-	-	-	PRATELEIRA MOVEL	SHELF	ESTANTERIA	448 X 438 X 15	1
15	16394	134	-	-	-	-	-	-	-	RODAPE FRONTAL	BOTTOM BOARD FRONT	ZÓCALO FRONTAL	1726 X 70 X 15	1
16	16395	20	-	-	-	-	-	-	-	RODAPE TRASEIRO	BOTTOM BOARD BACK	ZÓCALO TRASERO	1726 X 70 X 15	1
17	16396	20	-	-	-	-	-	-	-	RODAPE INTERNO	BOTTOM BOARD INTERNAL	ZÓCALO INTERNO	561 X 70 X 15	3
18	19204	138	-	-	-	-	-	-	-	TAMPO GAVETEIRO ESQUERDO	SHELF	ESTANTERIA	820 X 450 X 15	1
19	19261	138	-	-	-	-	-	-	-	TAMPO DO CALCEIRO	SHELF	ESTANTERIA	438 X 300 X 15	1
20	20439	138	-	-	-	-	-	-	-	TRASEIRO	BACK PANEL	TRASERO	2207 X 455 X 3	2
21	20440	138	-	-	-	-	-	-	-	TRASEIRO	BACK PANEL	TRASERO	2207 X 417 X 3	2
22	28069	20	-	-	-	-	-	-	-	APOYO DE GAVETA	DRAWER SUPPORT	APOYO DE GAVETA	400 X 70 X 12	3
23	29075	134	-	-	-	-	-	-	-	VISTA LATERAL	SIDE FRAME	VISIÓN LATERAL	2296 X 85 X 18	2
24	29108	134	-	-	-	-	-	-	-	VISTA SUPERIOR	UPPER VIEW	VISTA SUPERIOR	1756 X 85 X 18	1
25	14319	150	-	-	-	-	-	-	-	PORTA DE CORRER	SLIDING DOOR	PUERTA CORREDIZA	2150 X 857 X 15	1
26	14320	138	-	-	-	-	-	-	-	PORTA DE CORRER	SLIDING DOOR	PUERTA CORREDIZA	2150 X 857 X 12	1

LISTA DE ACESSÓRIOS / LIST OF ACCESSORIES / LISTA DE ACCESORIOS

SEQ.	CODIGO.	DESCRIÇÃO	DESCRIPTION_EN	DESCRIPCION_ES	QTD.
-	01300	KIT DE ACESSÓRIOS	KIT OF ACCESSORIES	KIT DE ACCESORIOS	1
A	9905002	PARAFUSO 3.5 X 12 MM CHATA PHILIPS	PHILIPS FLAT HEAD SCREW	TORNILLO CHATA PHILIPS	102
B	9905003	PARAFUSO 3.5 X 12 MM FLANGEADO PHILIPS	PHILIPS FLANGE SCREW	TORNILLO DE BRIDA PHILIPS	4
BC	9920077	SISTEMA PORTA CORRER KIT 02 PORTAS FOLGA ZERO GUIA VERMELHO 99206 COM ROLAMENTO	SLIDING DOOR SYSTEM	SISTEMA DE PUERTAS CORREDERAS	1
C	9905004	PARAFUSO 3.5 X 16 MM CHATA PHILIPS	PHILIPS FLAT HEAD SCREW	TORNILLO CHATA PHILIPS	30
CA	9919059	TRILHO DUPLO INFERIOR 1725 MM LAR 47 ALUMINIO COD 1055 BRONZE	LOWER DOUBLE RAIL	RIEL DOBLE INFERIOR	1
CB	9919060	TRILHO SUPERIOR E 1725 MM ALUMINIO COD 1031 BRONZE LARG 67 - MM	TOP RAIL E	RIEL SUPERIOR	1
DB	9901074	CABIDEIRO OBLONGO 812 X 25 X 15 MM ALUMINIO	HANGER	PERCHERO	1
DB	9901088	CABIDEIRO OBLONGO 430 X 25 X 15 MM ALUMINIO	HANGER	PERCHERO	2
E	9905020	PARAFUSO 3.5 X 30 MM CHATA PHILIPS	PHILIPS FLAT HEAD SCREW	TORNILLO CHATA PHILIPS	27
EA	9902037	MOLDURA DE ALUMINIO 2148 X 15 MM CHAPA15 MM COD 1557 ABA FRONTAL 4 MM BRONZE	ALUMINUM FRAME	MARCO DE ALUMINIO	2
FC	9902040	PERFIL PUXADOR ALUMINIO 2148 MM COD 1110 2 MM BRONZE	HANDLE	TIRADOR	2
H	9905015	PARAFUSO 4.5 X 45 MM CHATA PHILIPS	PHILIPS FLAT HEAD SCREW	TORNILLO CHATA PHILIPS	41
IA	9928014	PERFIL H 2180 X 16 X 6 MM PLASTICO	PLASTIC H STRIP	TIRA PLASTICA H	1
IB	9928023	PERFIL I 342 X 16 X 6 MM PLASTICO	PLASTIC I STRIP	TIRA PLASTICA I	1
IC	9912005	ETIQUETA LOGO DEMARTEZ	TAG	ETIQUETA	1
J	9920029	PINO MINIFIX 12 MM	MINIFIX PIN	PINO MINIFIX	6
K	9920009	CASTANHA MINIFIX 12 MM	MINIFIX CHESTNUT	LOS SIMPSON	6
L	9920011	CAVILHAS 6 X 30 MM	WOODEN PEG	CLAVIJA DE MADERA	58
M	9920012	CAVILHAS 6 X 50 MM	WOODEN PEG	CLAVIJA DE MADERA	4
MA	9920053	JUNCAO METALICA 50 X 13 MM	METAL JUNCTION	JUNCIÓN METALICA	2
O	9913004	CORREDICA TELESCOPICA LARG 32 MM DE 350 MM METAL	TELESCOPIC SLIDE	RIEL TELESCOPICA	3
OA	9912006	SACHET DE COLA 10 GRAMAS	GLUE	COLA	2
S	9920026	FIXADOR DE FUNDO 10 X 10 MM	BOOTOM FASTENER	FIJADOR DE FONDO	30
S1	9920040	SUPORTE PRATELEIRA 6 X 8	SHELF SUPPORT	SOPORTE DE ESTANTERIA	4
S3	9920038	SUPORTE CABIDE OBLONGO 20 MM	HANGER SUPPORT	SOPORTE DE PERCHERO	6
TA	9920060	CARTELA DE SILICONE	SILICONE CARTRIDGE	CARTÓN DE SILICONA	1
TB	9924014	CARTELA TAPA FUROS 18 MM ADESIVO	SCREW CAP	TAPA HUECOS	1
U	9924002	MINI SAPATA 15 MM	MINI SHOE	MINI ZAPATA	8
V	9920030	PORCA CILINDRICA 9 X 12 MM	CYLINDRICAL NUT	TUERCA CILINDRICA	38
W	9906001	PREGO 12X12 MM	NAIL	CLAVO	8
X	9906002	PREGO 9X9 MM	NAIL	CLAVO	140
Z	9920007	CANTONEIRA ZAMAC 12 MM	METAL ANGLE BRACKET	ESQUINERAS METALICAS	12

Acessórios/Accessories/Accessorios

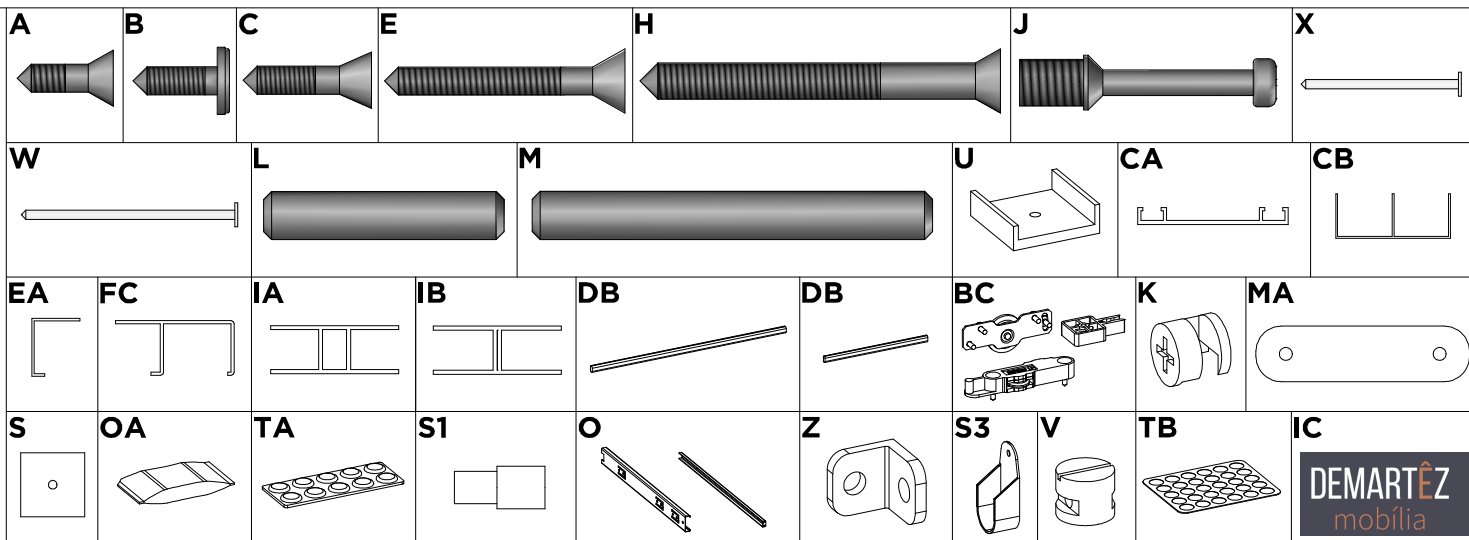

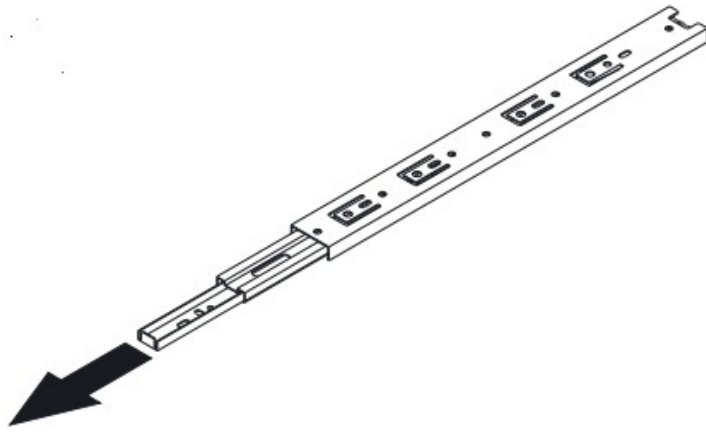

1º

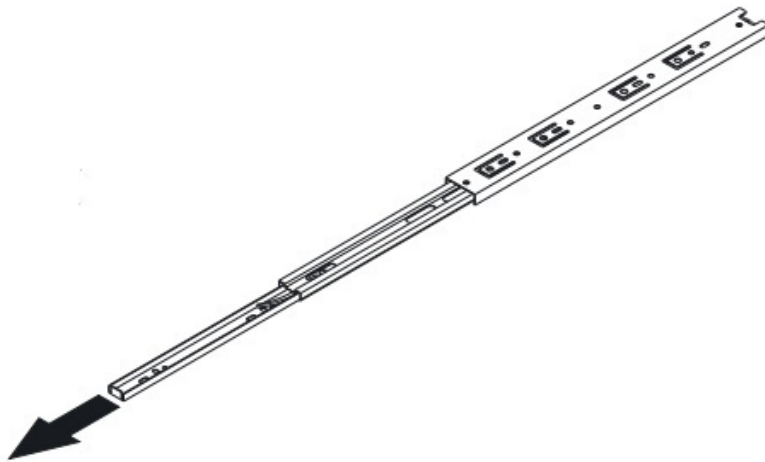

2º

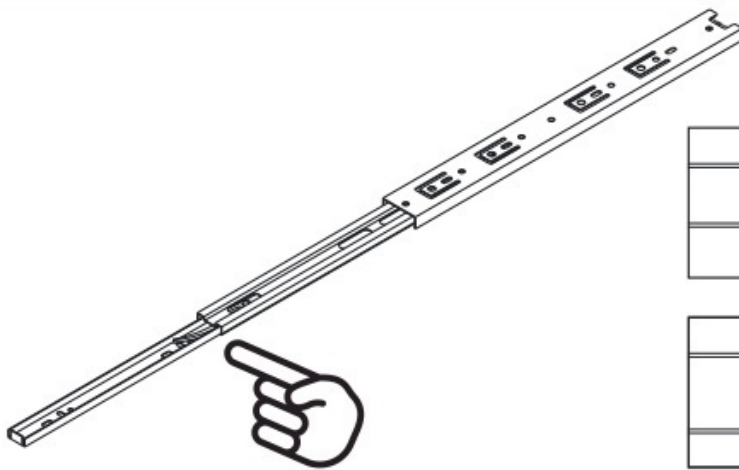

3º

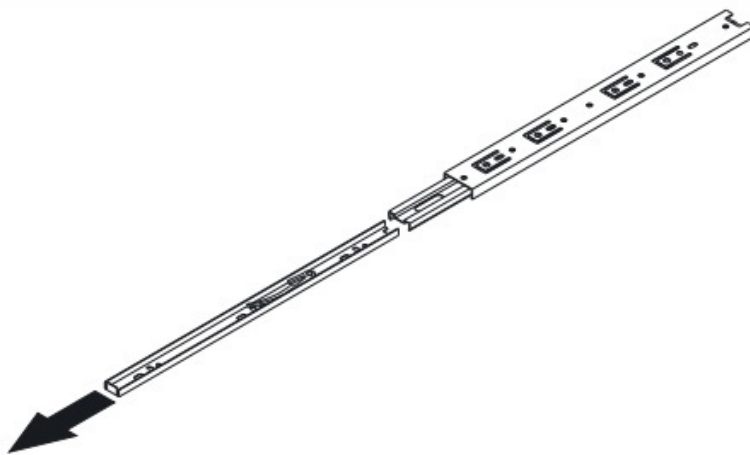
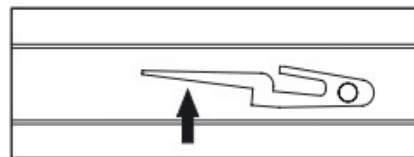
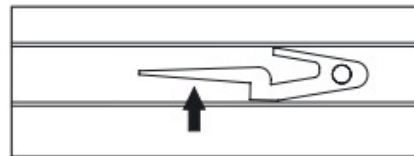

4º

01

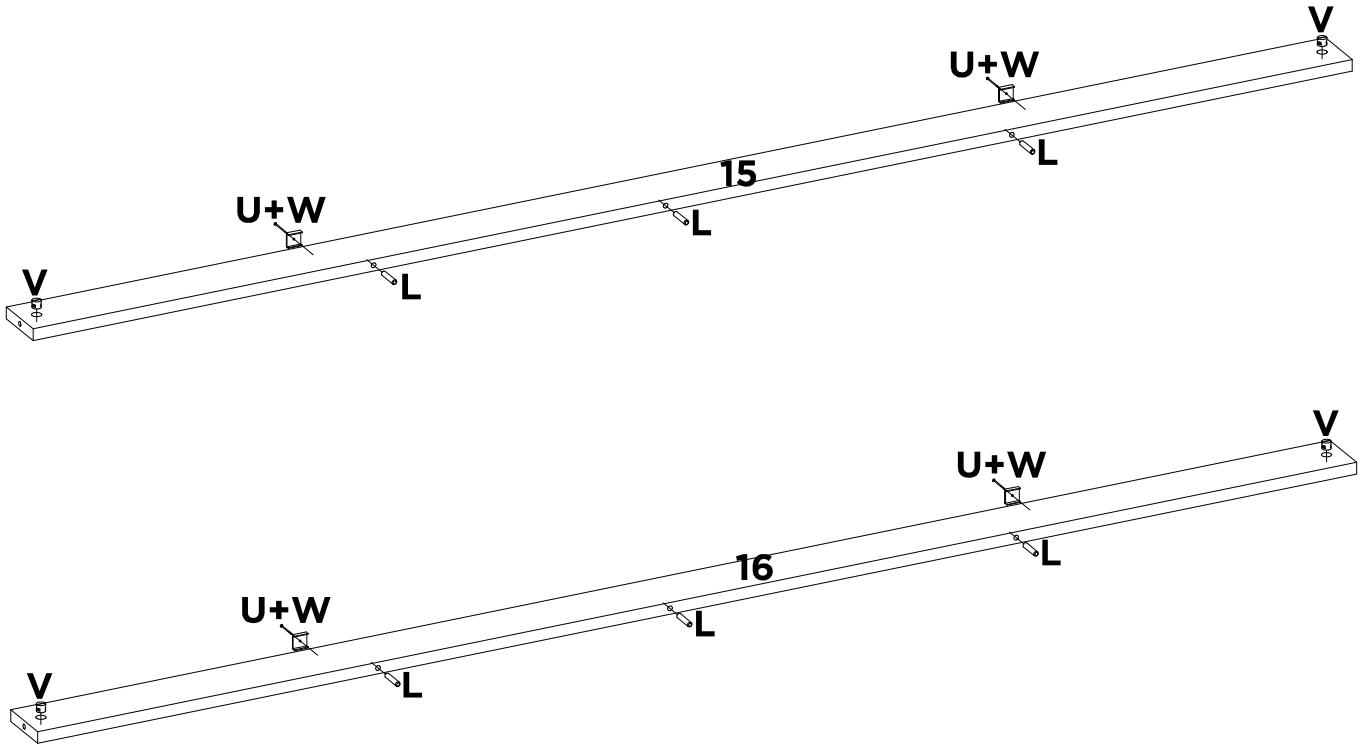

L	U	V	W	-	-	-	-
X6	X4	X4	X4	-	-	-	-

01A

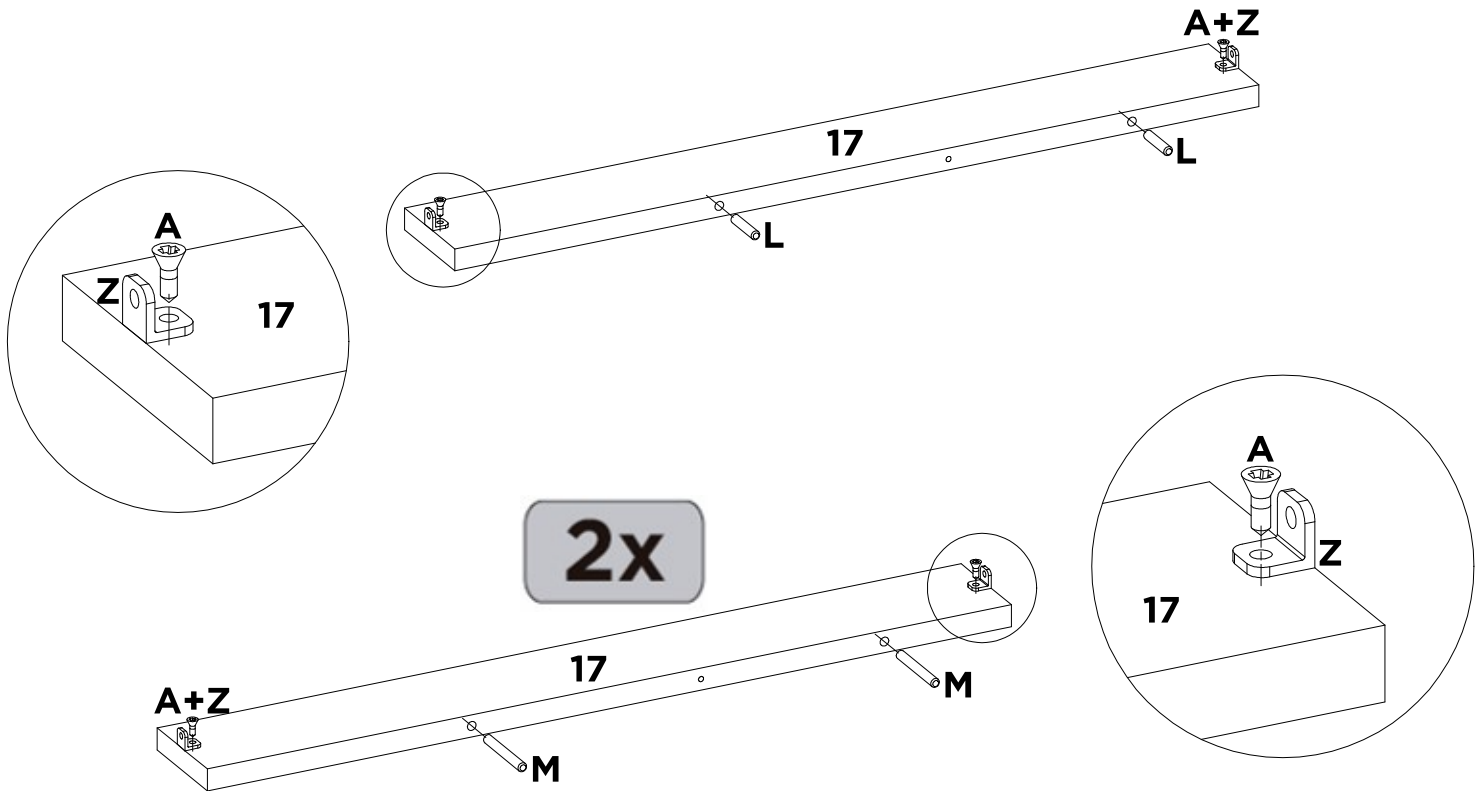

A	L	M	Z	-	-	-	-
X6	X2	X4	X6	-	-	-	-

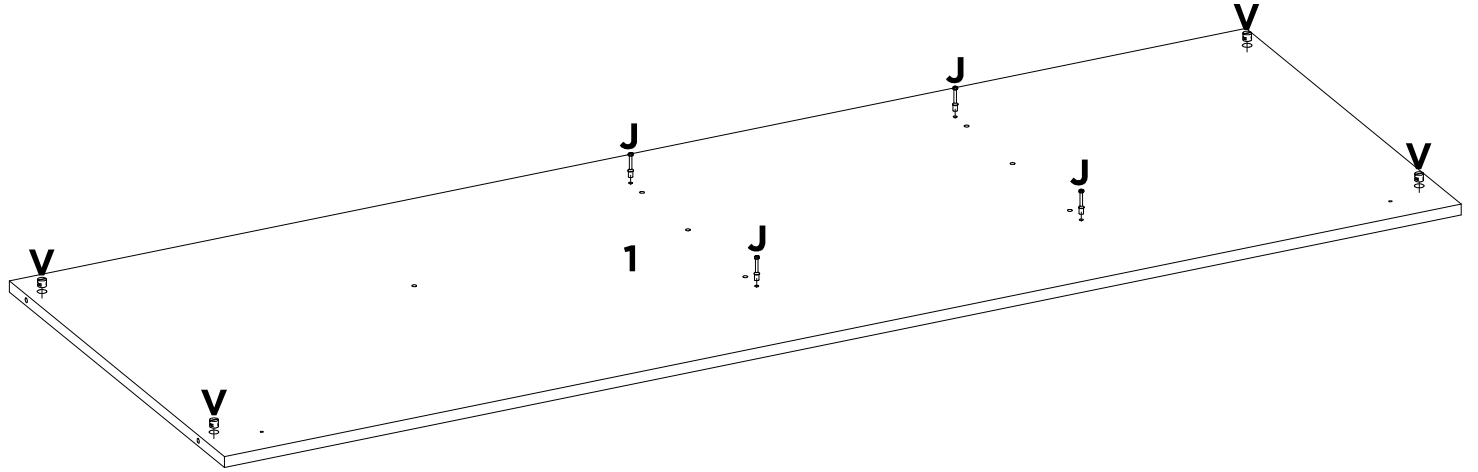

J	V	-	-	-	-	-	-
X4	X4	-	-	-	-	-	-

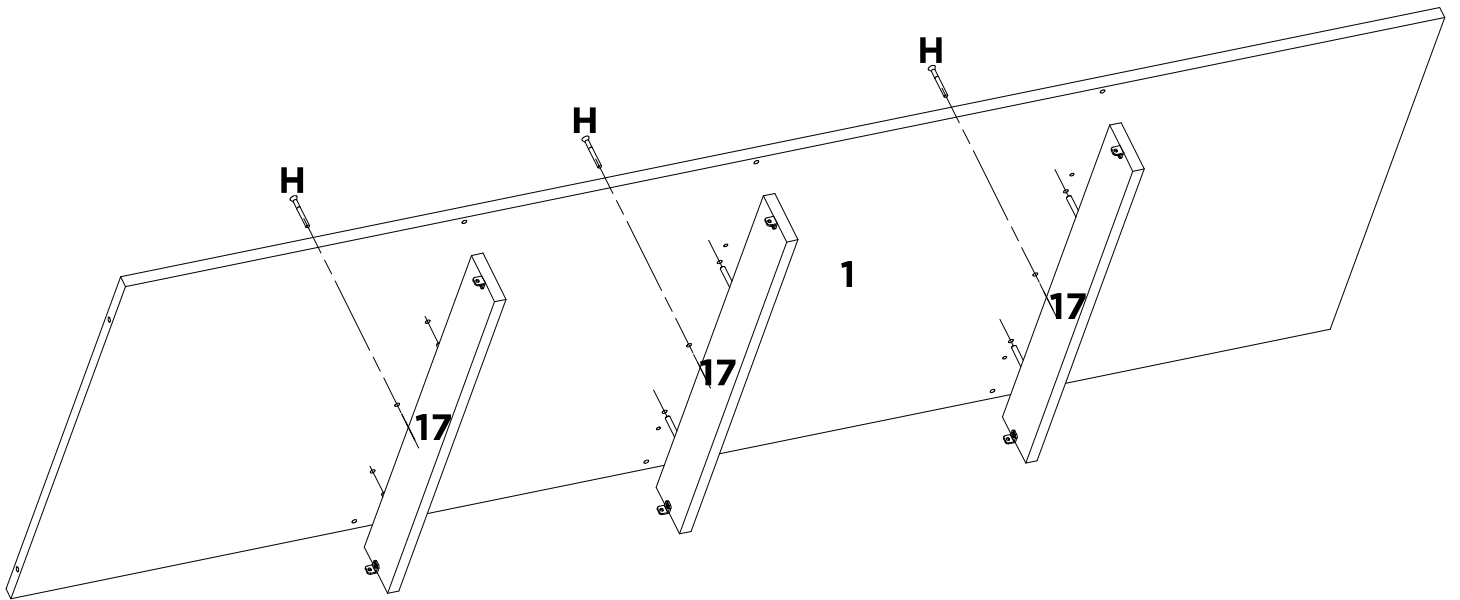

H	-	-	-	-	-	-	-
X3	-	-	-	-	-	-	-

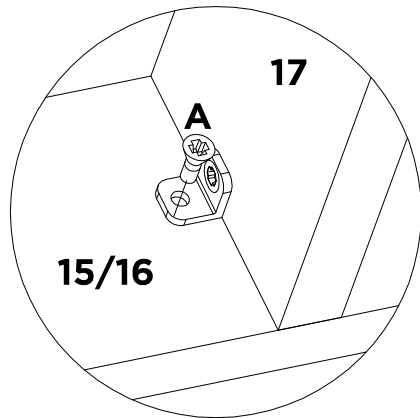
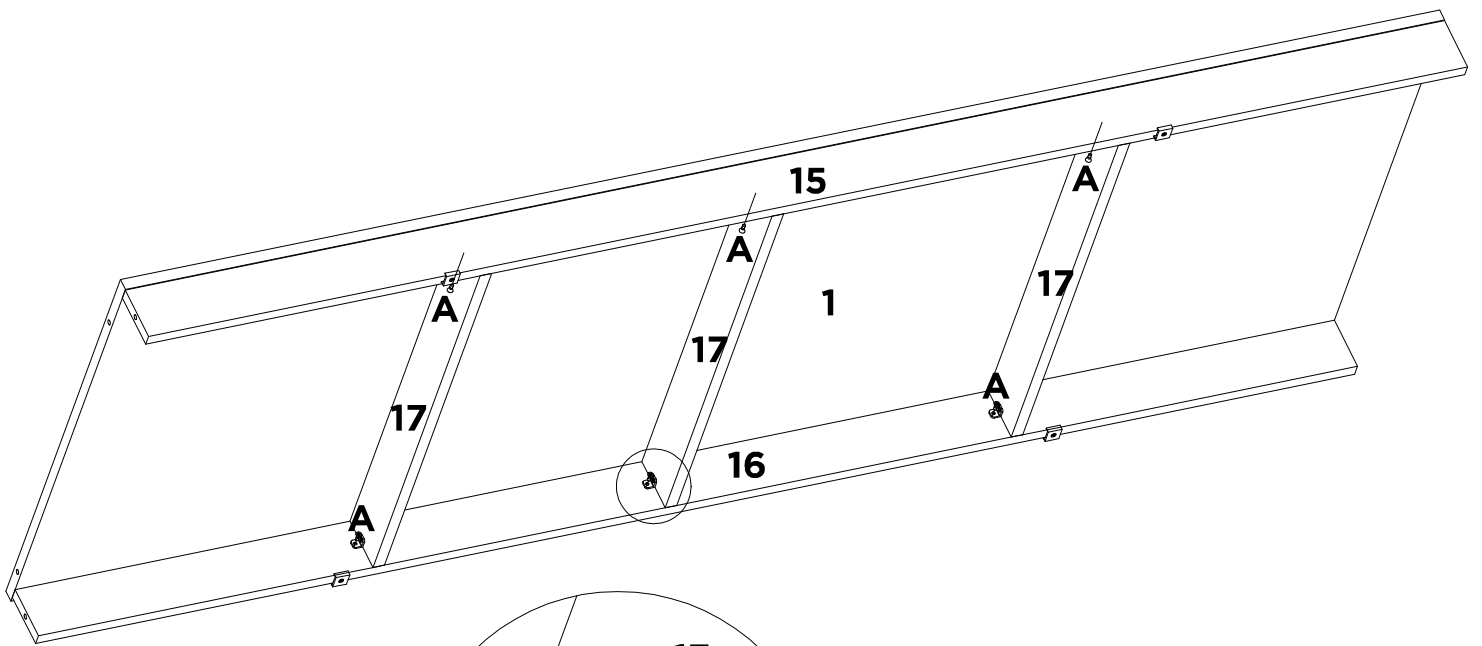

A	-	-	-	-	-	-	-
X6	-	-	-	-	-	-	-

05

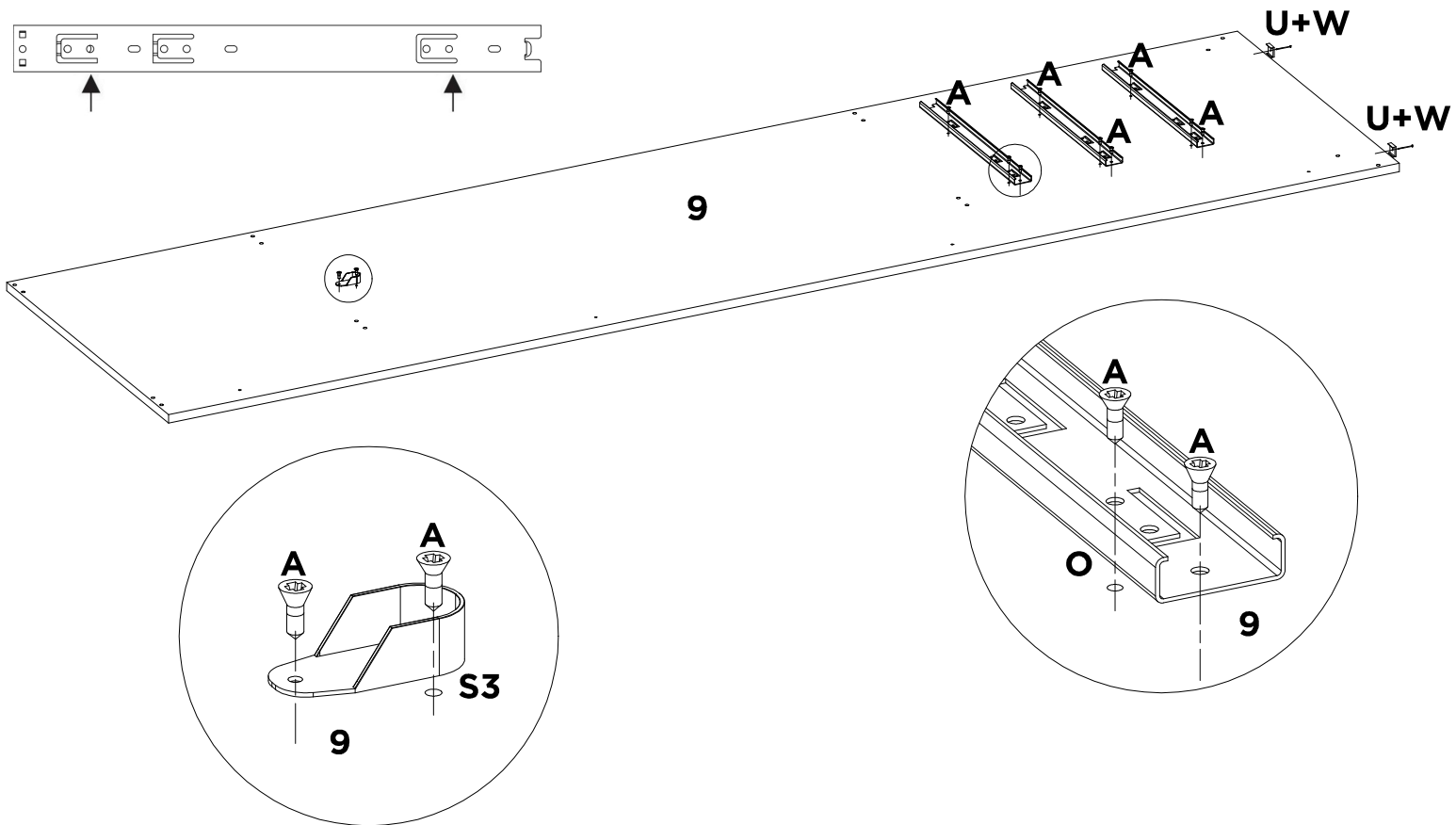

A	O	S3	U	W	-	-	-
X11	X3	X1	X2	X2	-	-	-

06

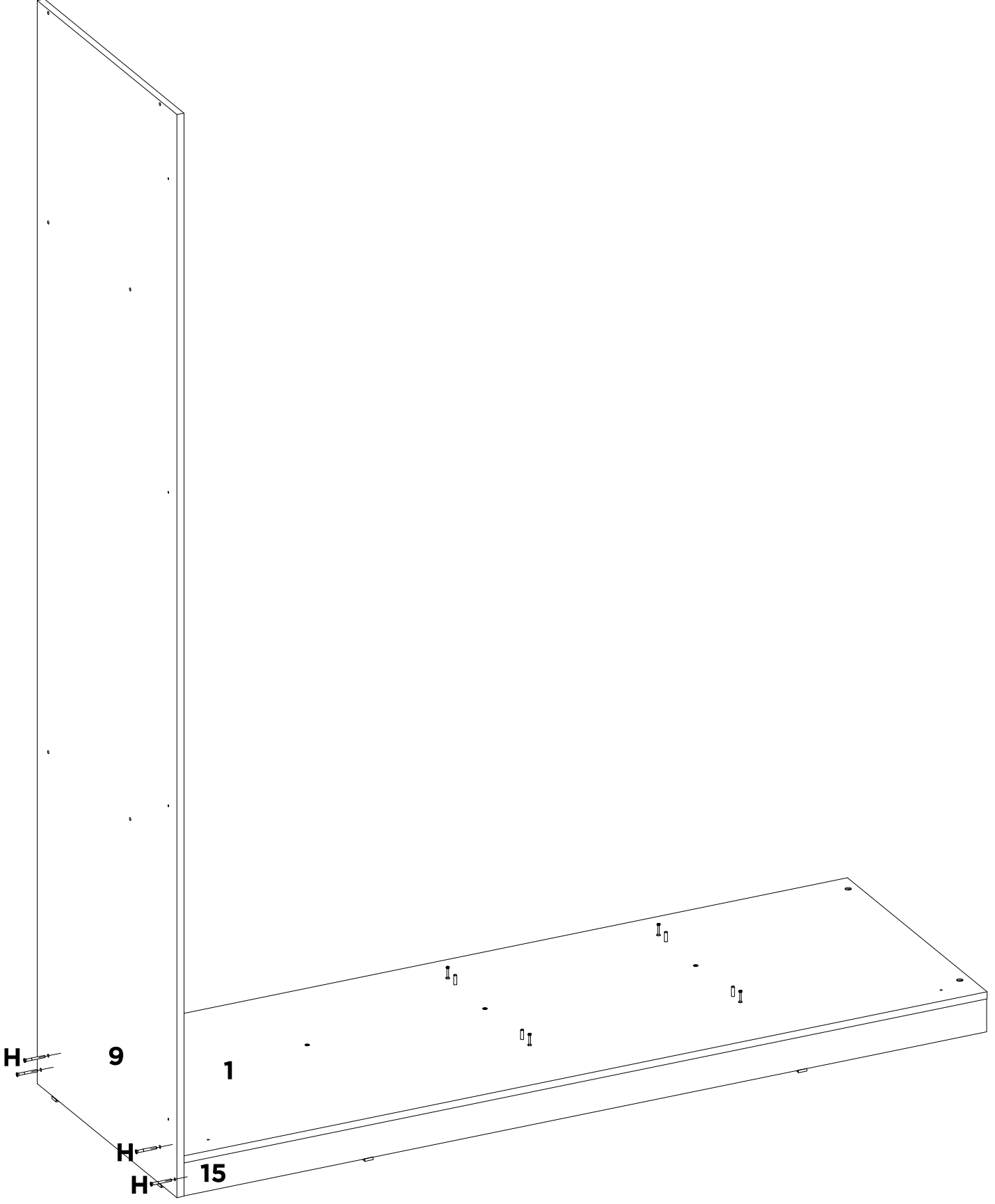

H	-	-	-	-	-	-	-
X4	-	-	-	-	-	-	-

07

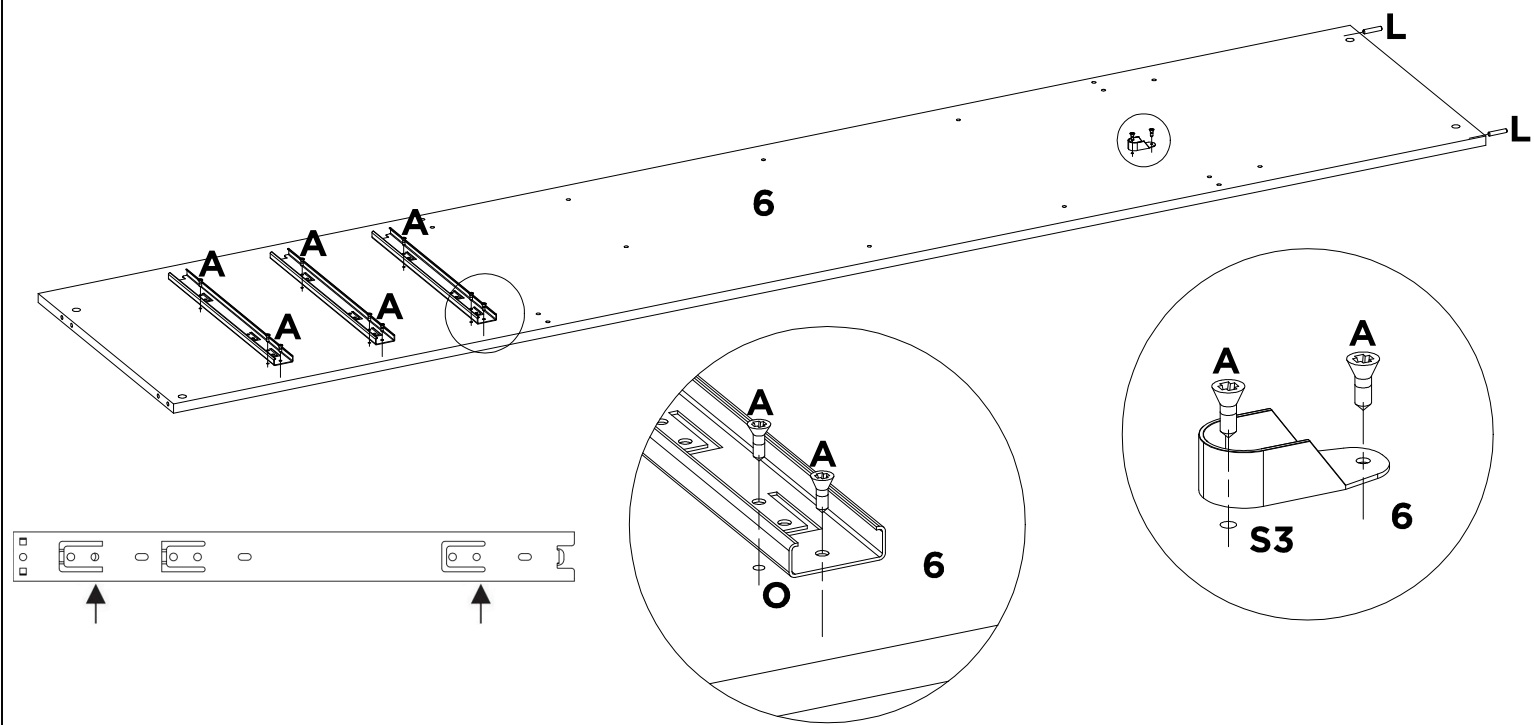

A	L	O	S3	-	-	-	-
X11	X2	X3	X1	-	-	-	-

07A

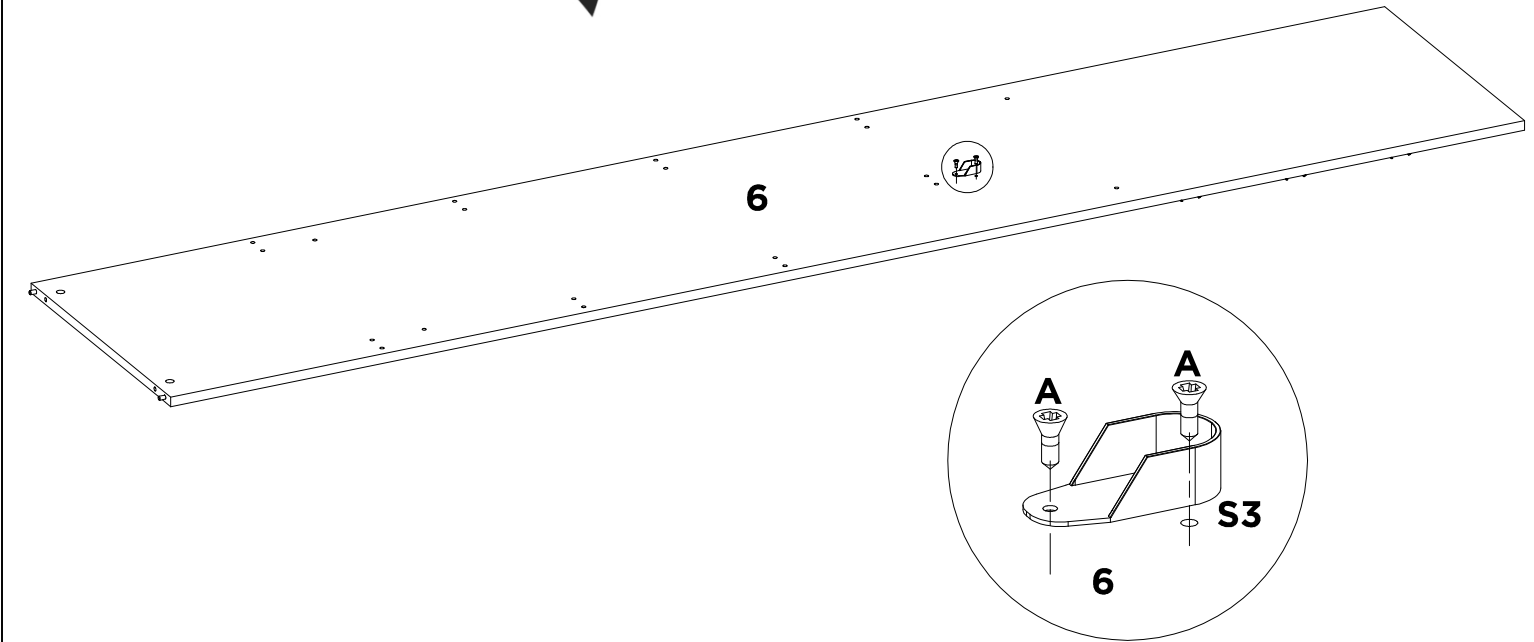

A	S3	-	-	-	-	-	-
X2	X1	-	-	-	-	-	-

08

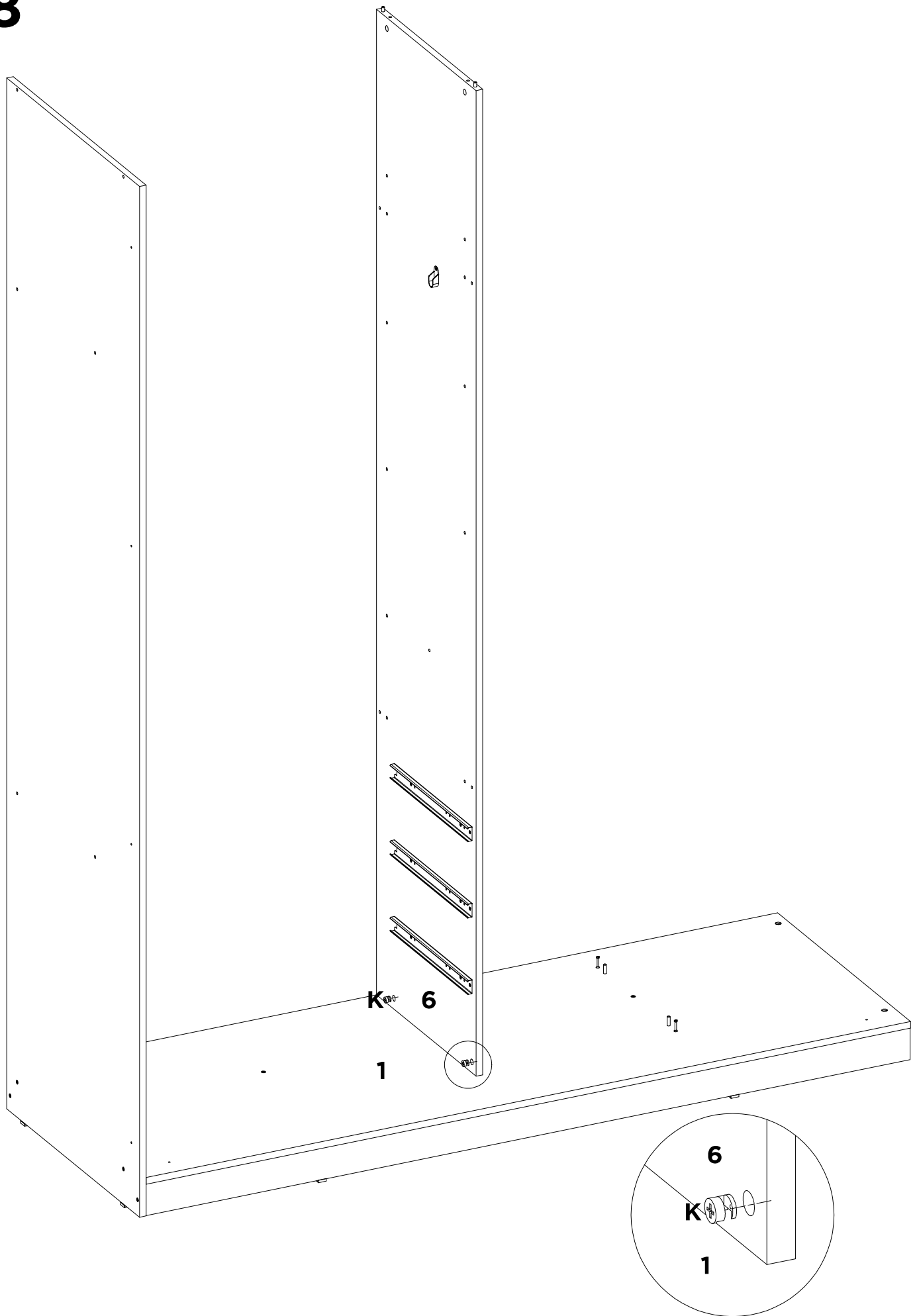

K	-	-	-	-	-	-	-
X2	-	-	-	-	-	-	-

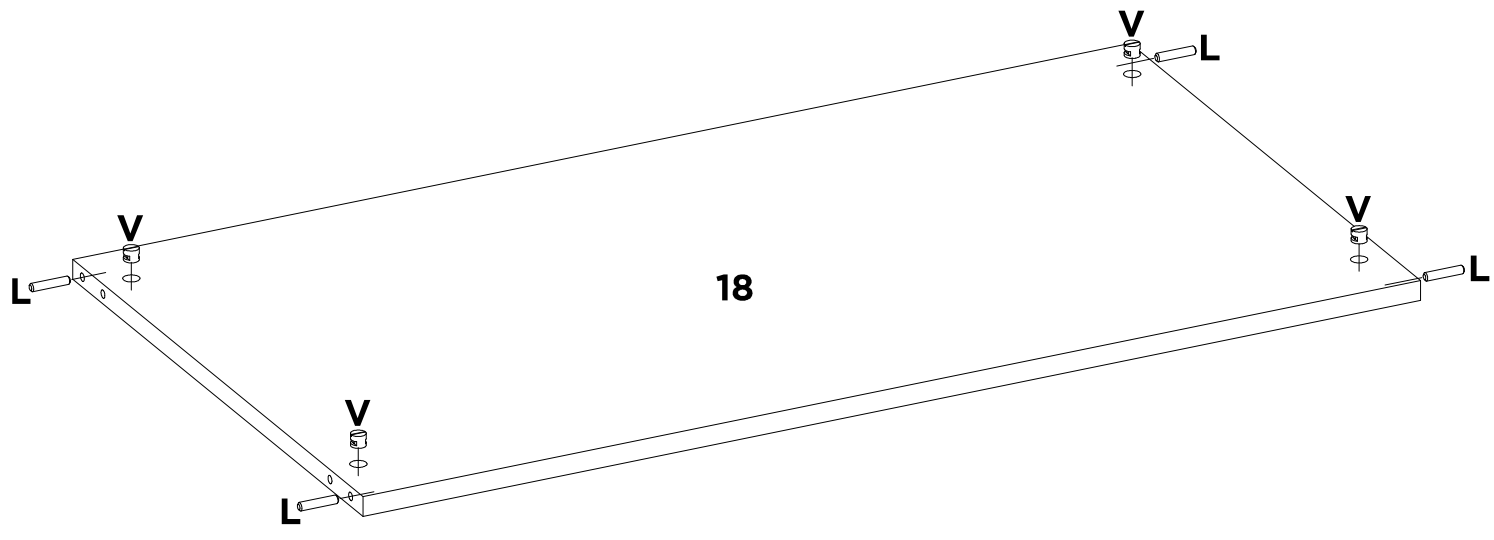

L	V	-	-	-	-	-	-
X4	X4	-	-	-	-	-	-

10

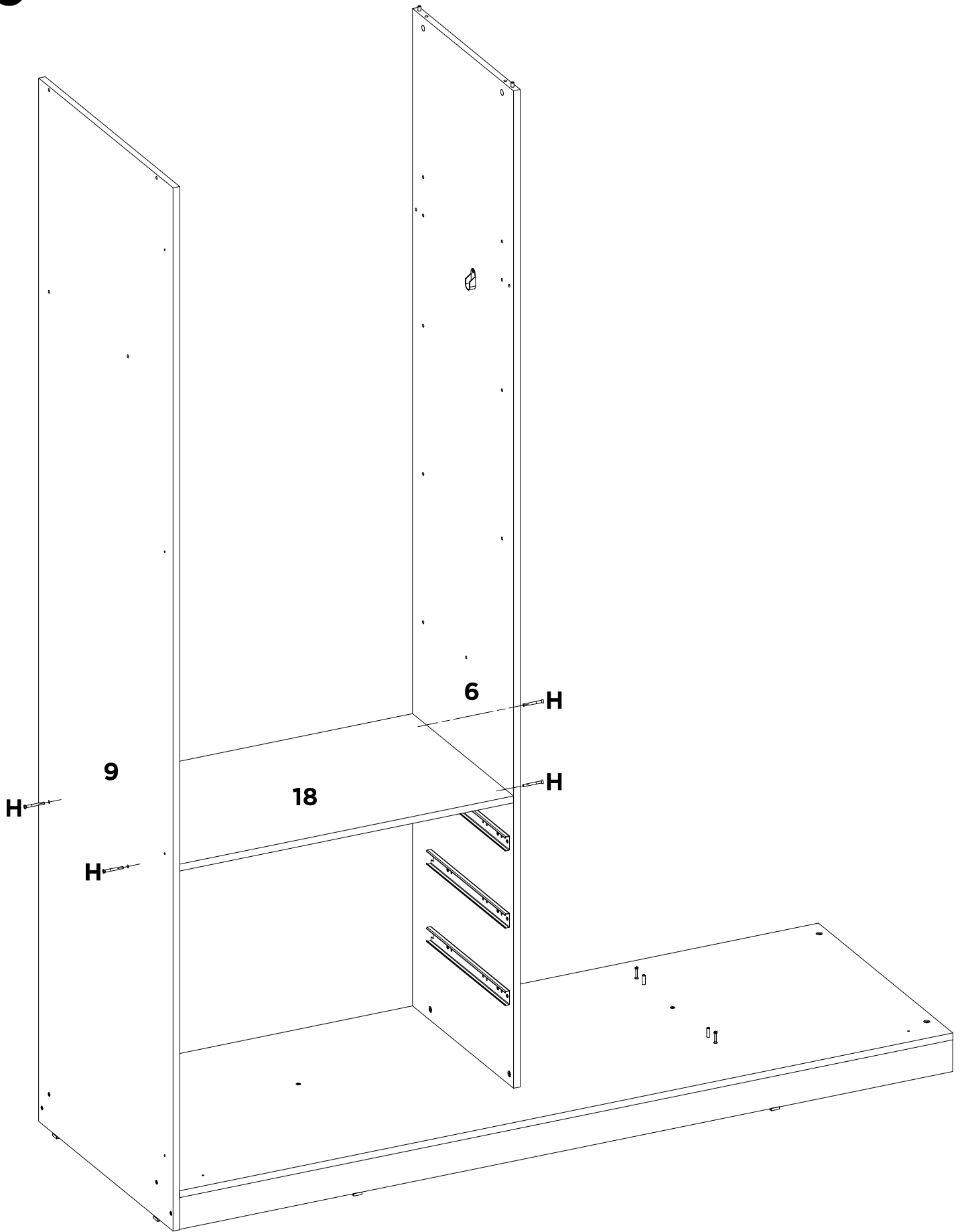

H	-	-	-	-	-	-	-
X4	-	-	-	-	-	-	-

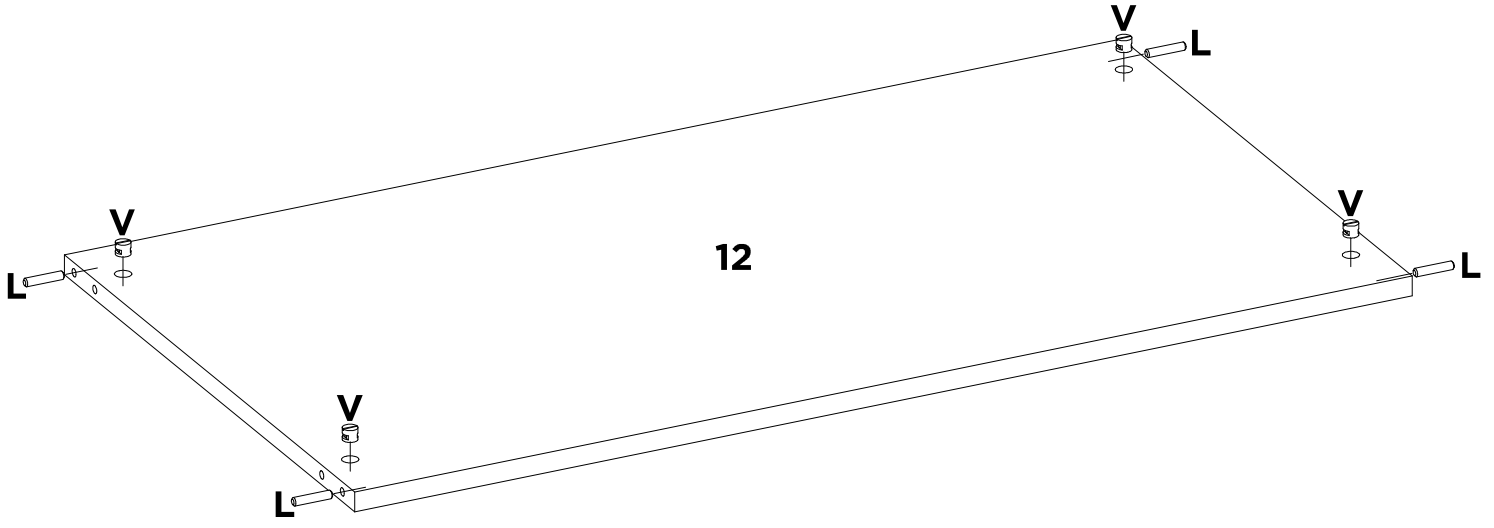

L	V	-	-	-	-	-	-
X4	X4	-	-	-	-	-	-

12

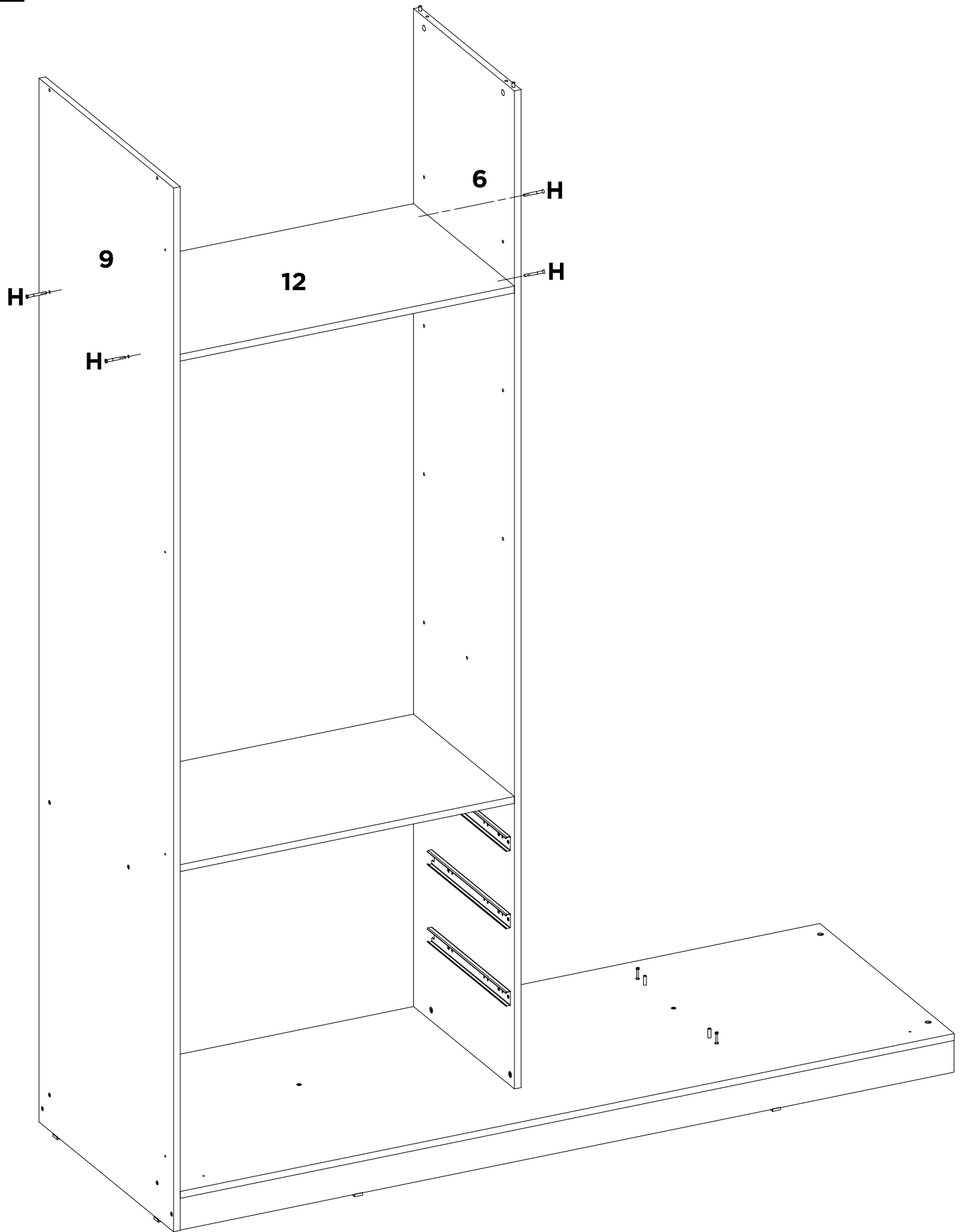

H	-	-	-	-	-	-	-
X4	-	-	-	-	-	-	-

13

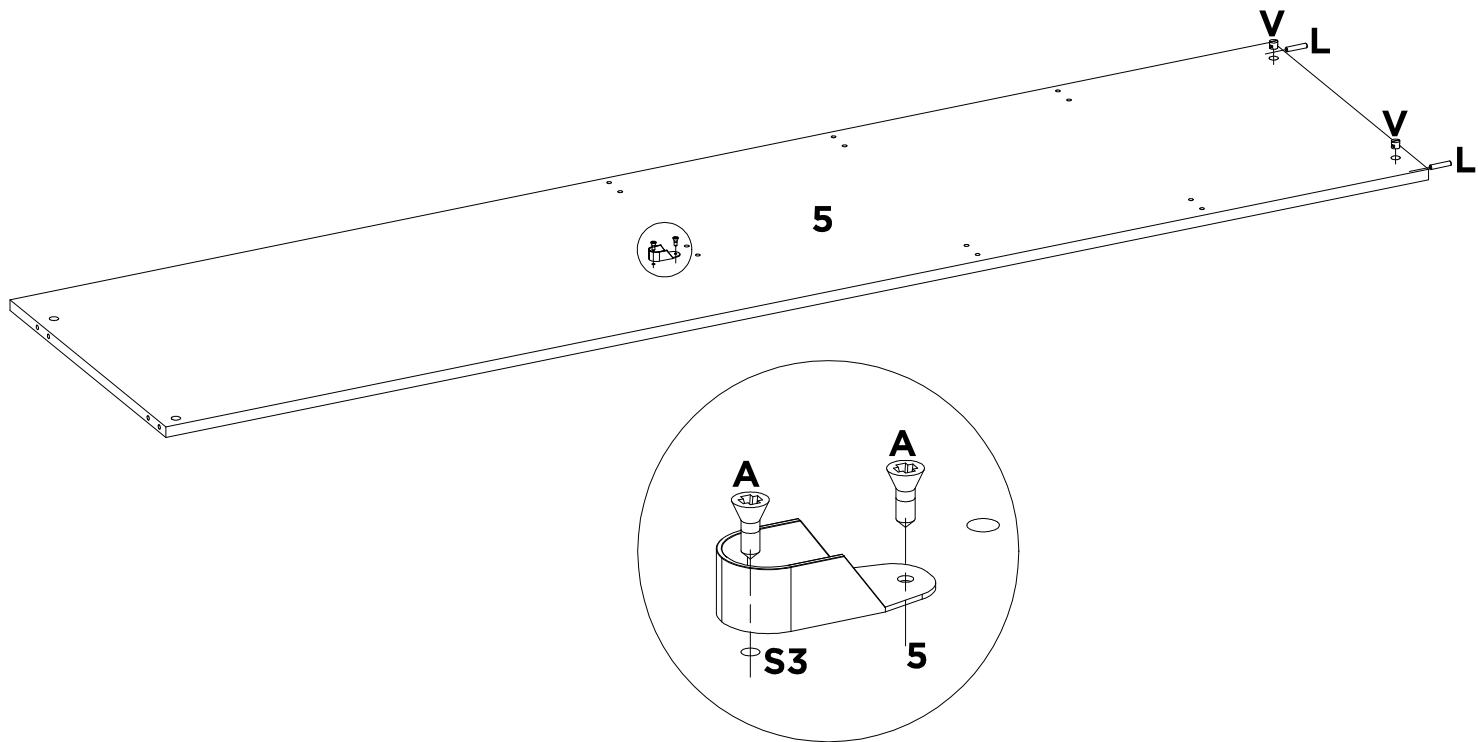

A	L	S3	V	-	-	-	-
X2	X2	X1	X2	-	-	-	-

13A

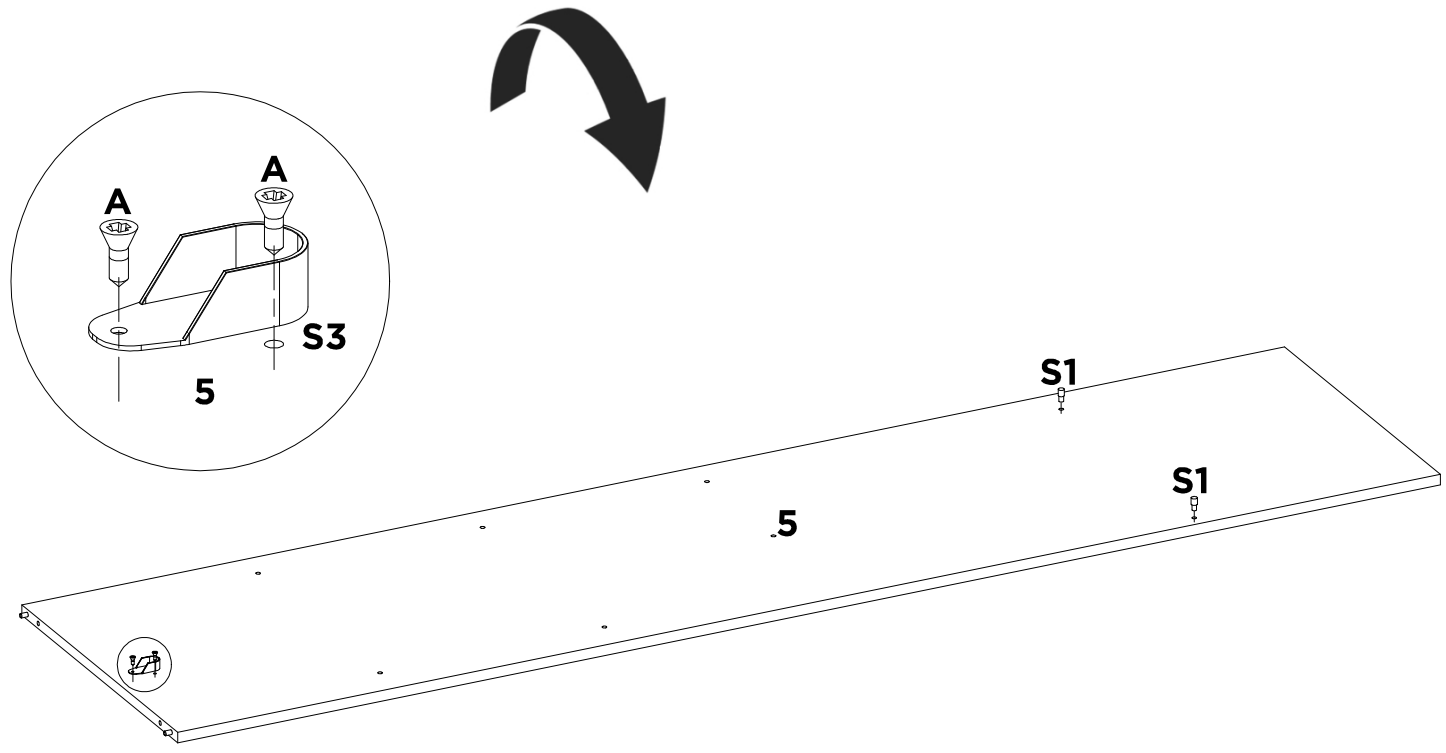

A	S1	S3	-	-	-	-	-
X2	X2	X1	-	-	-	-	-

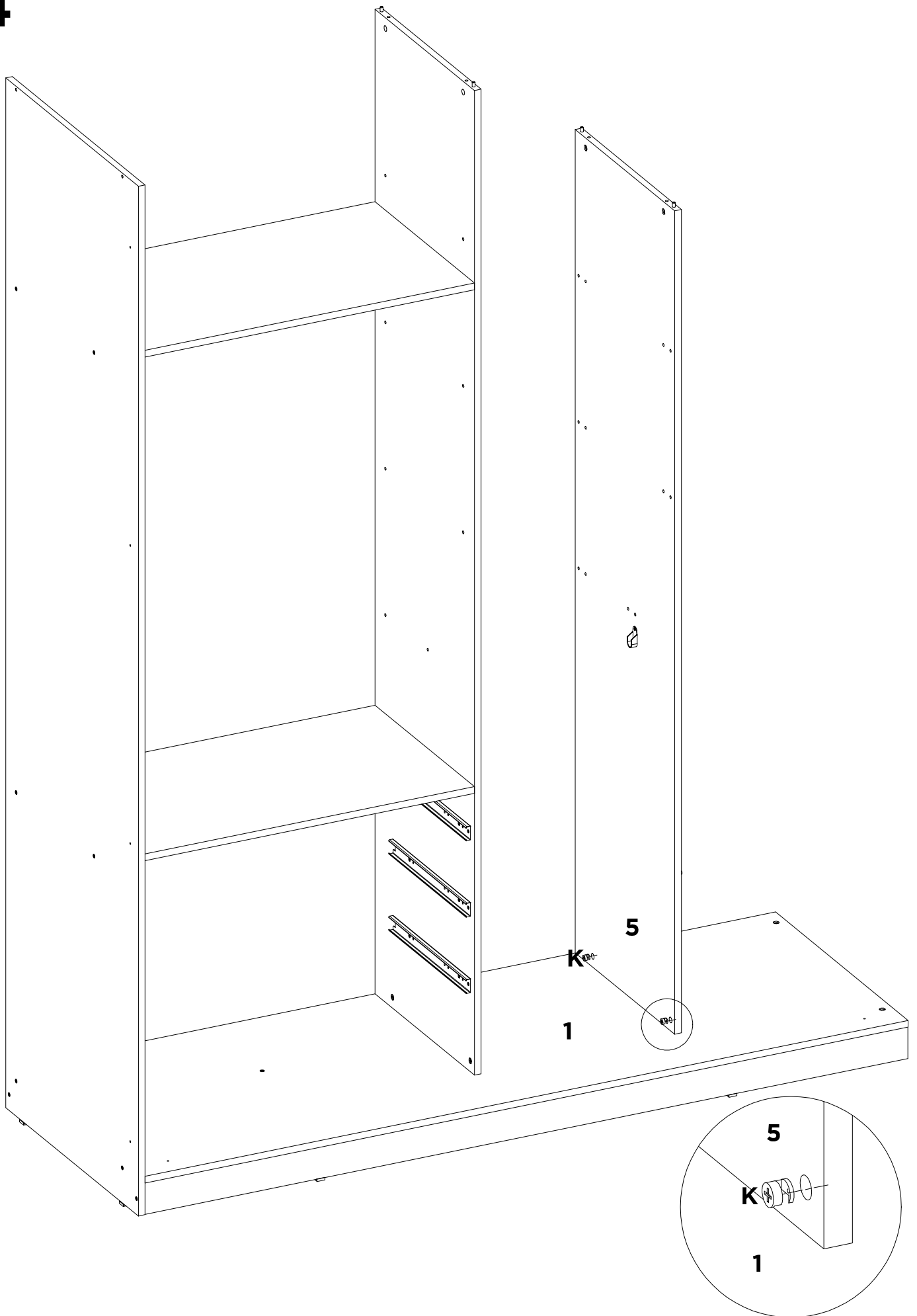

K	-	-	-	-	-	-	-
X2	-	-	-	-	-	-	-

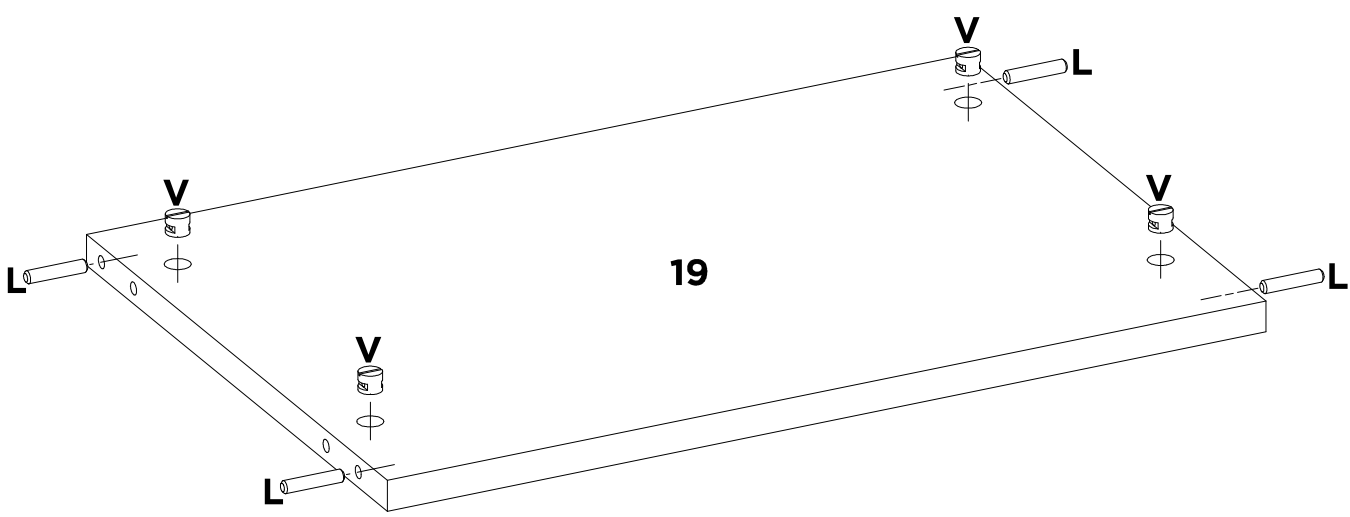

L	V	-	-	-	-	-	-
X4	X4	-	-	-	-	-	-

16

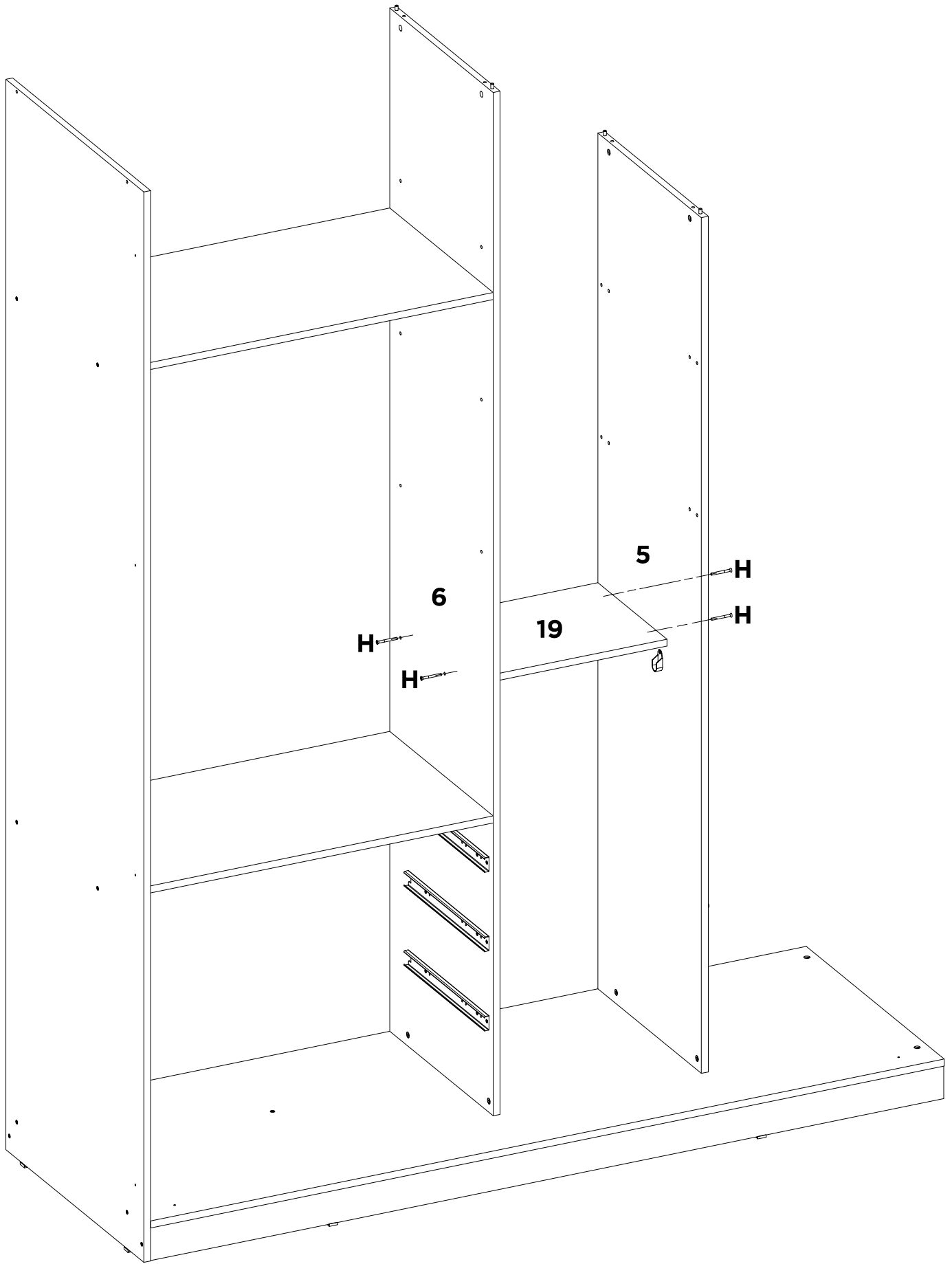

H	-	-	-	-	-	-	-
X4	-	-	-	-	-	-	-

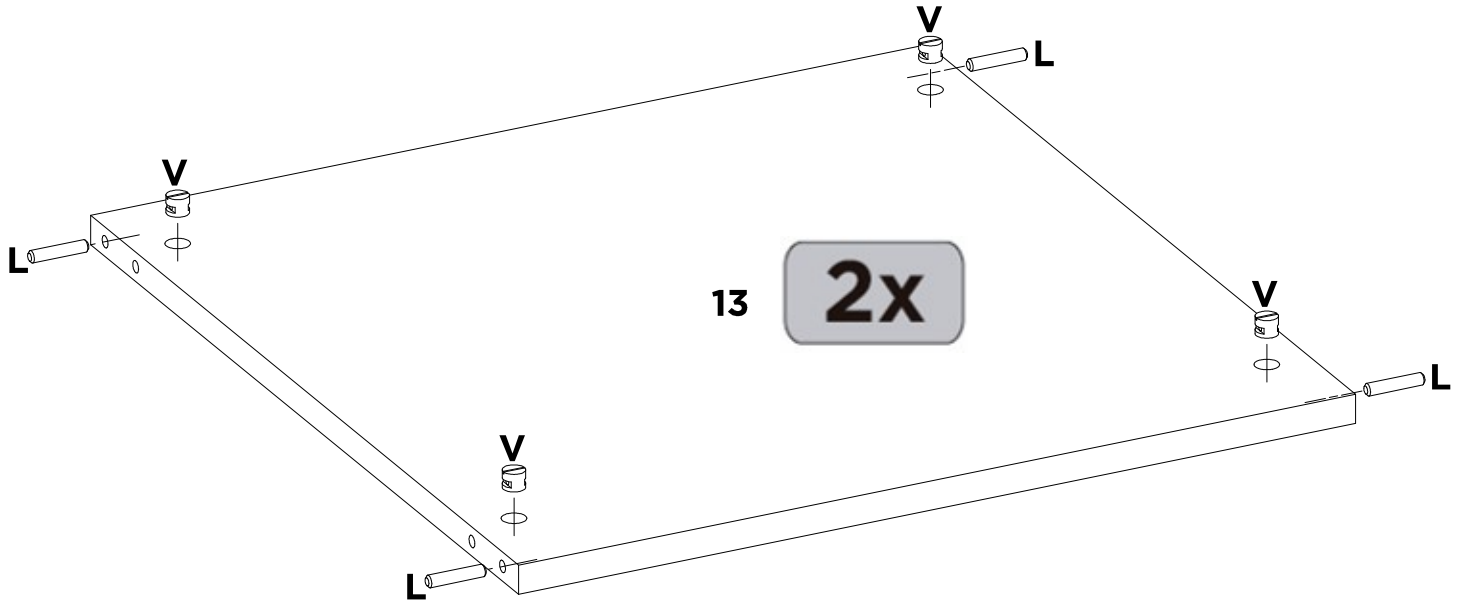

L	V	-	-	-	-	-	-
X8	X8	-	-	-	-	-	-

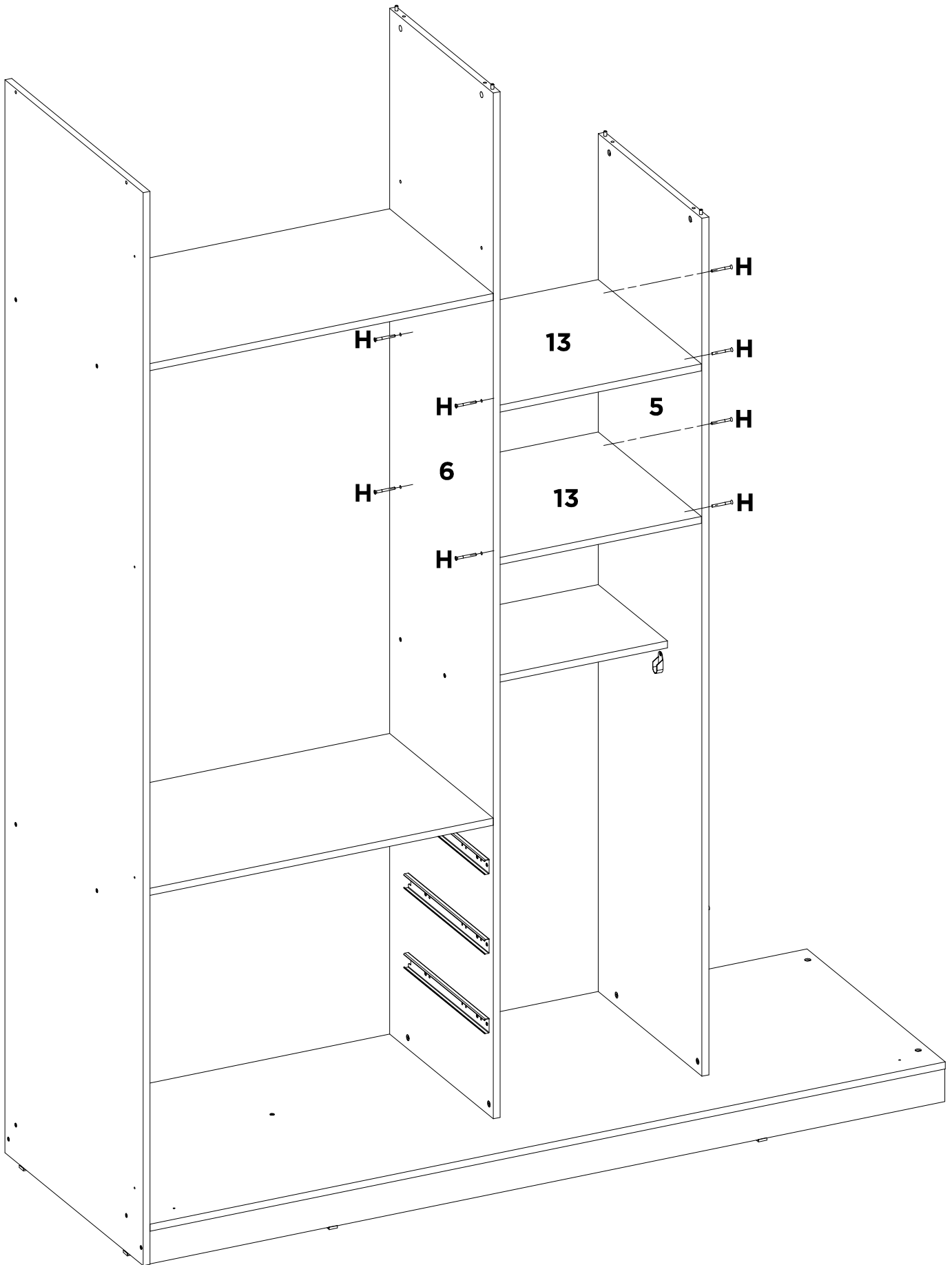

H	-	-	-	-	-	-	-
X8	-	-	-	-	-	-	-

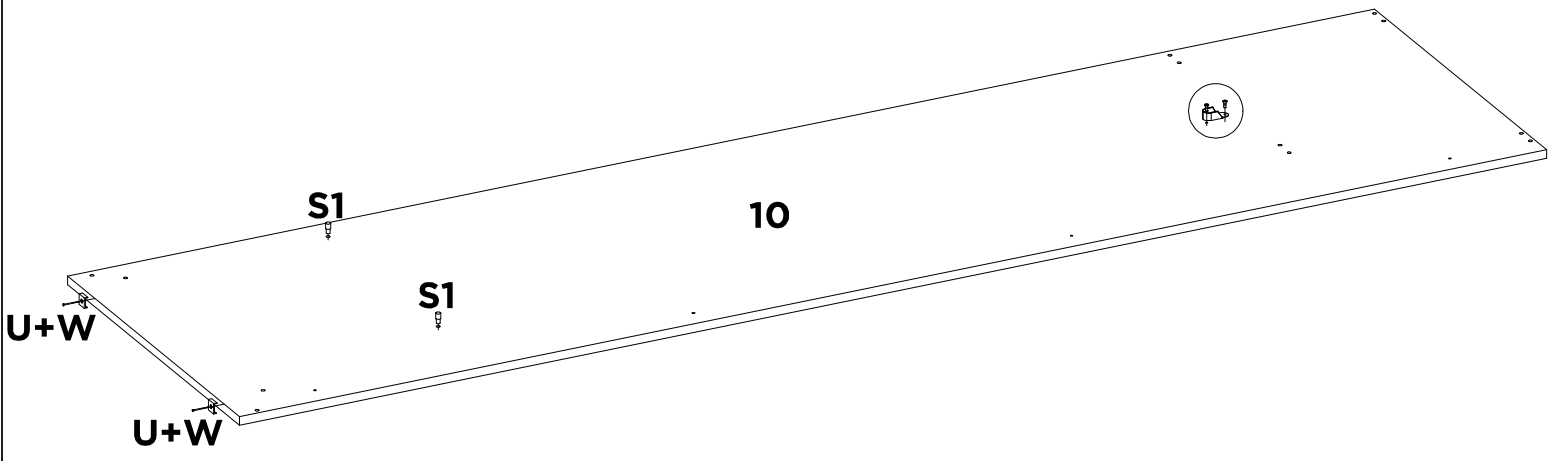
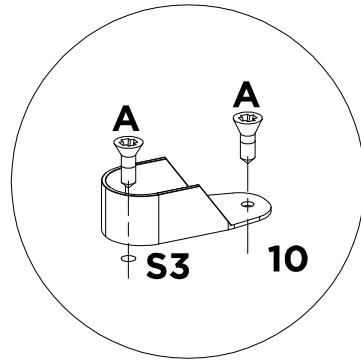

A	S1	S3	U	W	-	-	-
X2	X2	X1	X2	X2	-	-	-

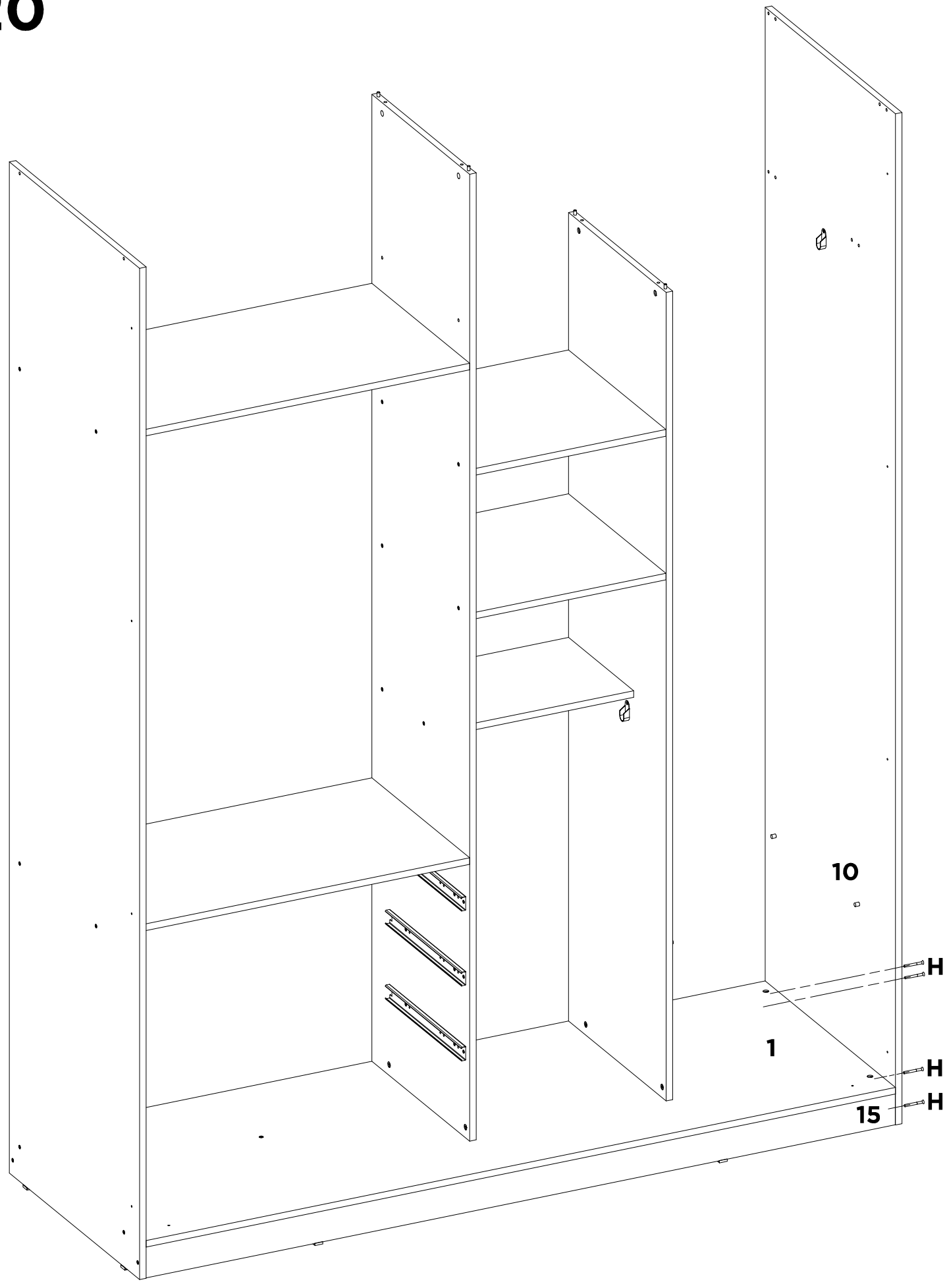

H	-	-	-	-	-	-	-
X4	-	-	-	-	-	-	-

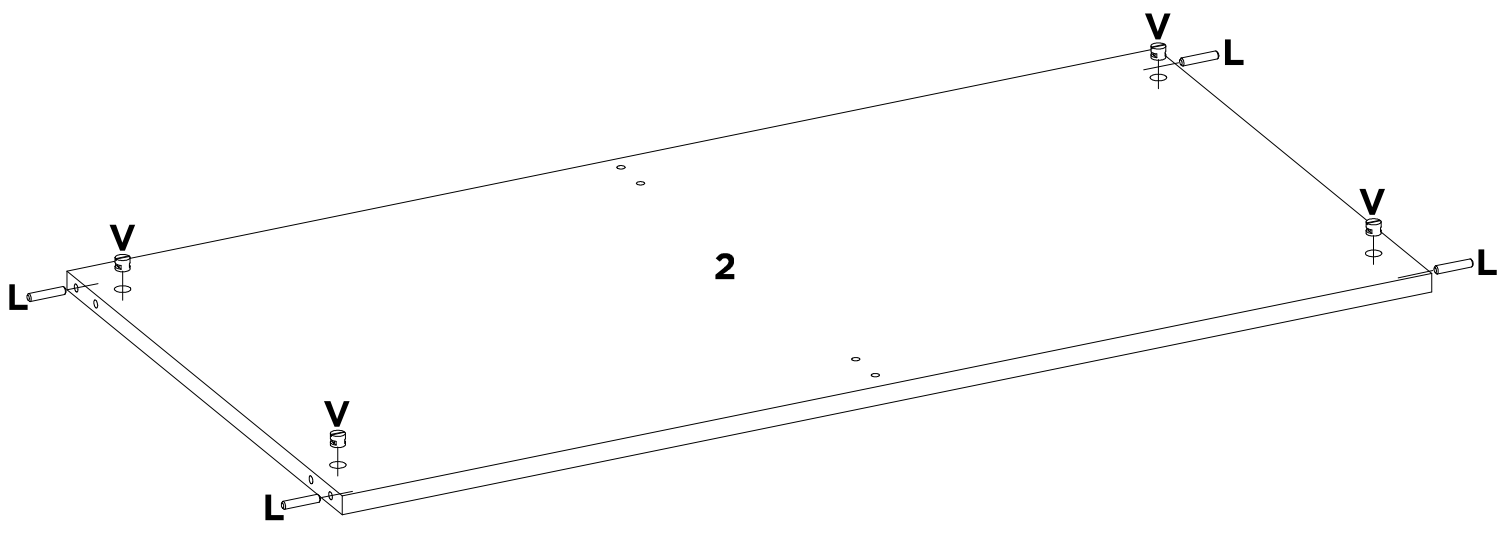

L	V	-	-	-	-	-	-
X4	X4	-	-	-	-	-	-

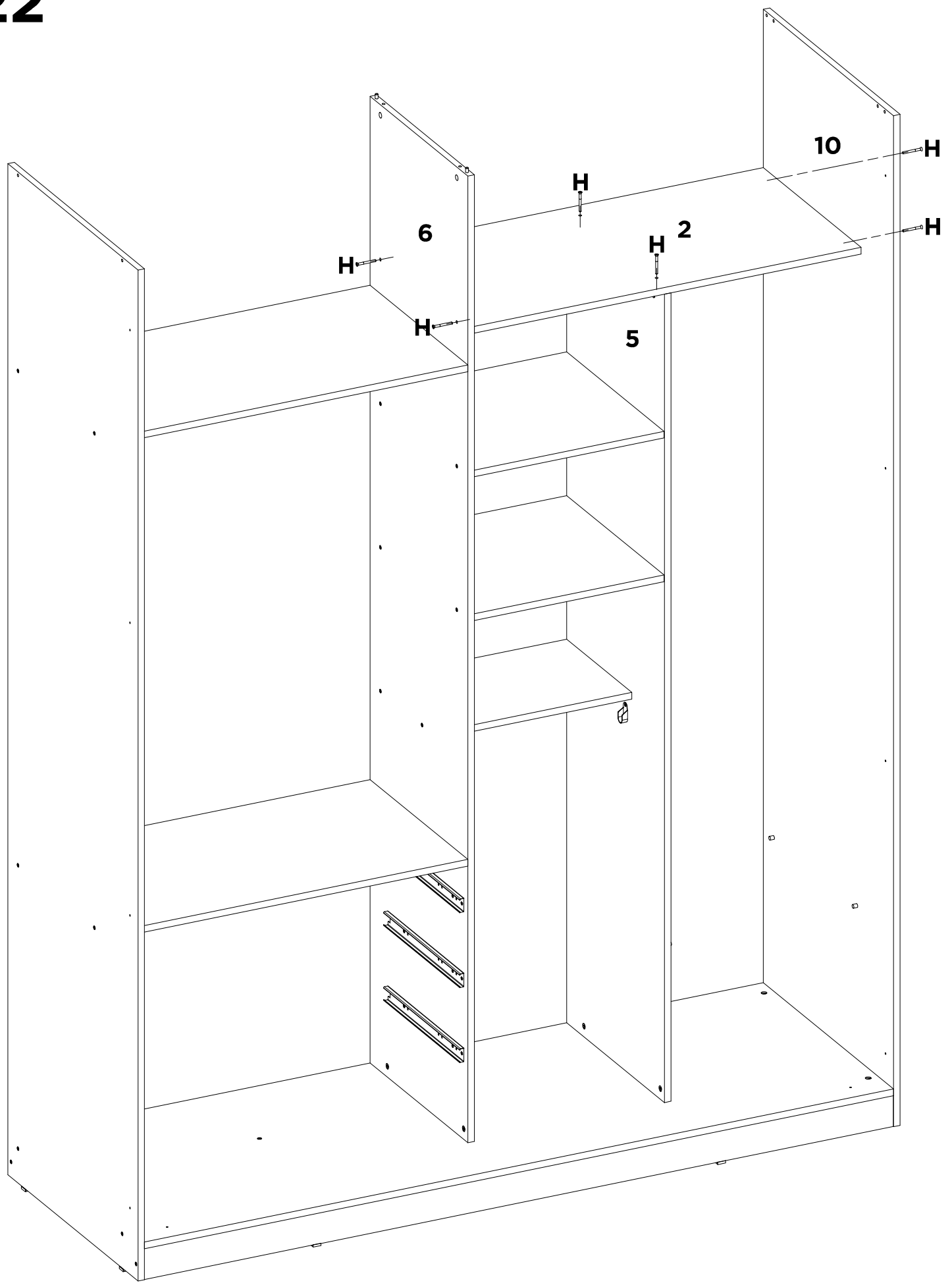

H	-	-	-	-	-	-	-
X6	-	-	-	-	-	-	-

23

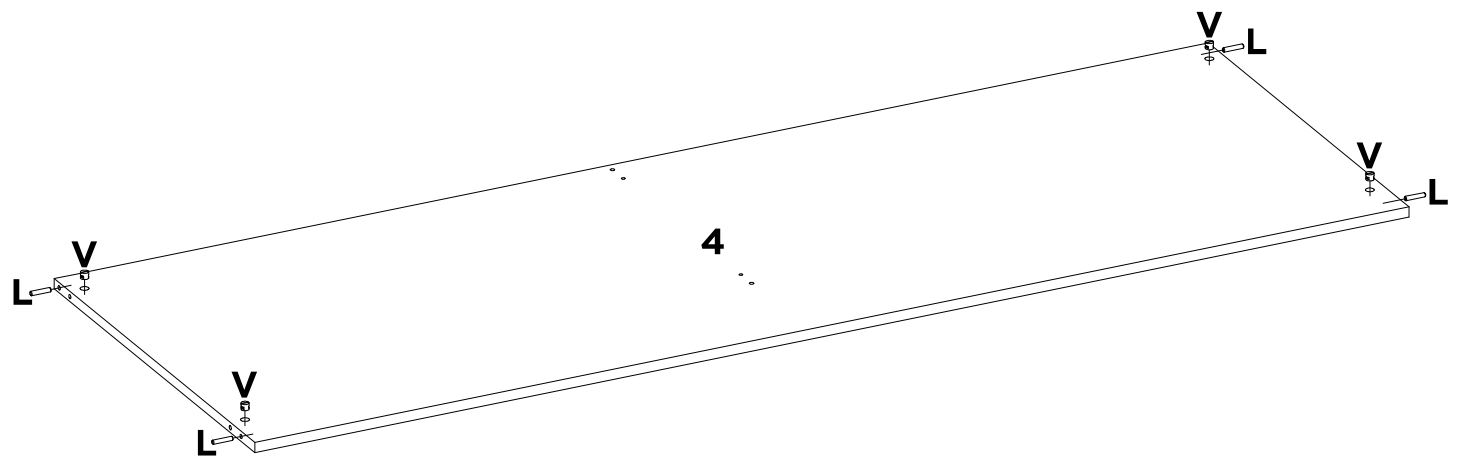

L	V	-	-	-	-	-	-
X4	X4	-	-	-	-	-	-

23A

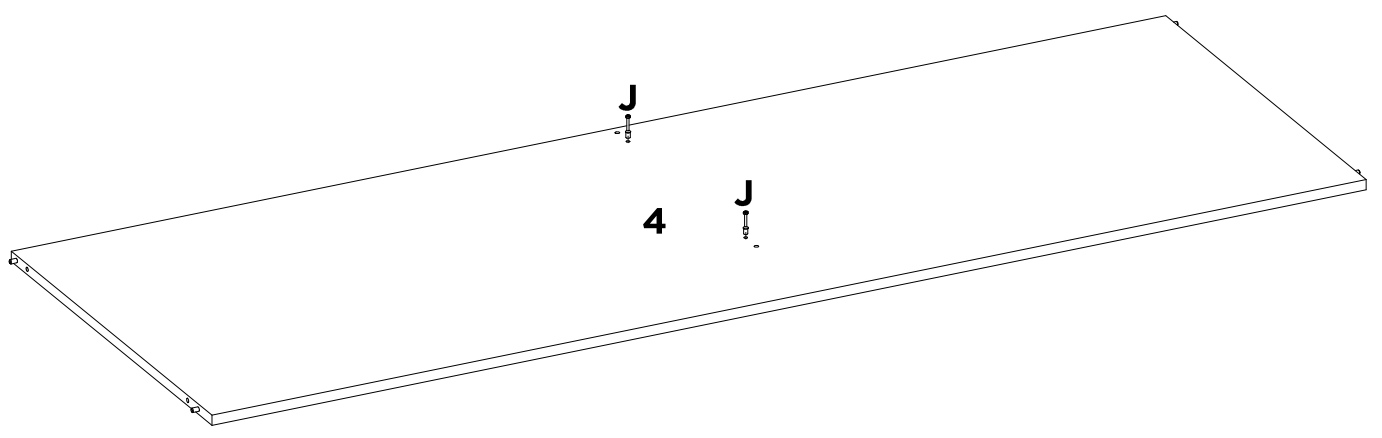

J	-	-	-	-	-	-	-
X2	-	-	-	-	-	-	-

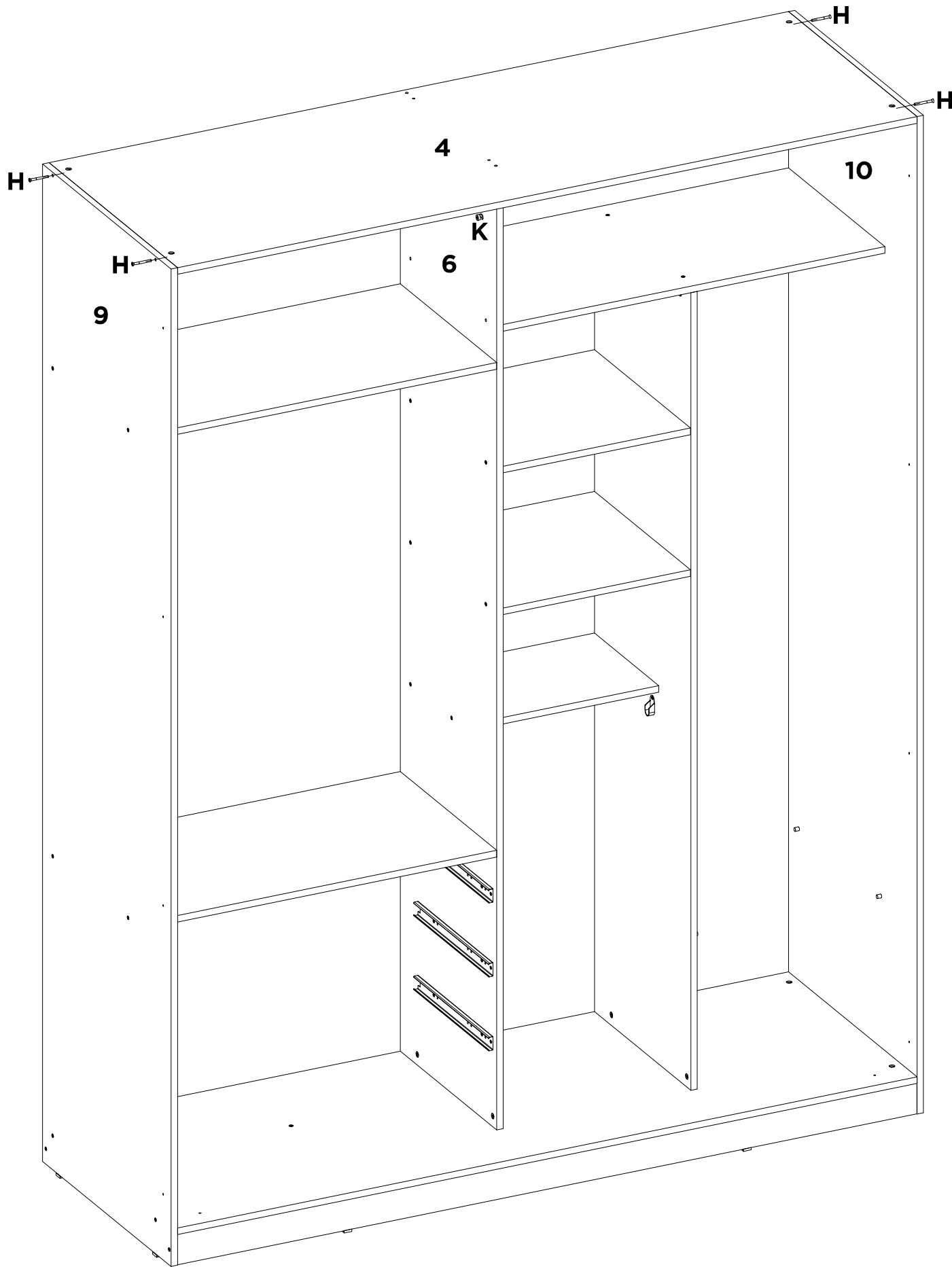

H	K	-	-	-	-	-	-
X4	X2	-	-	-	-	-	-

25

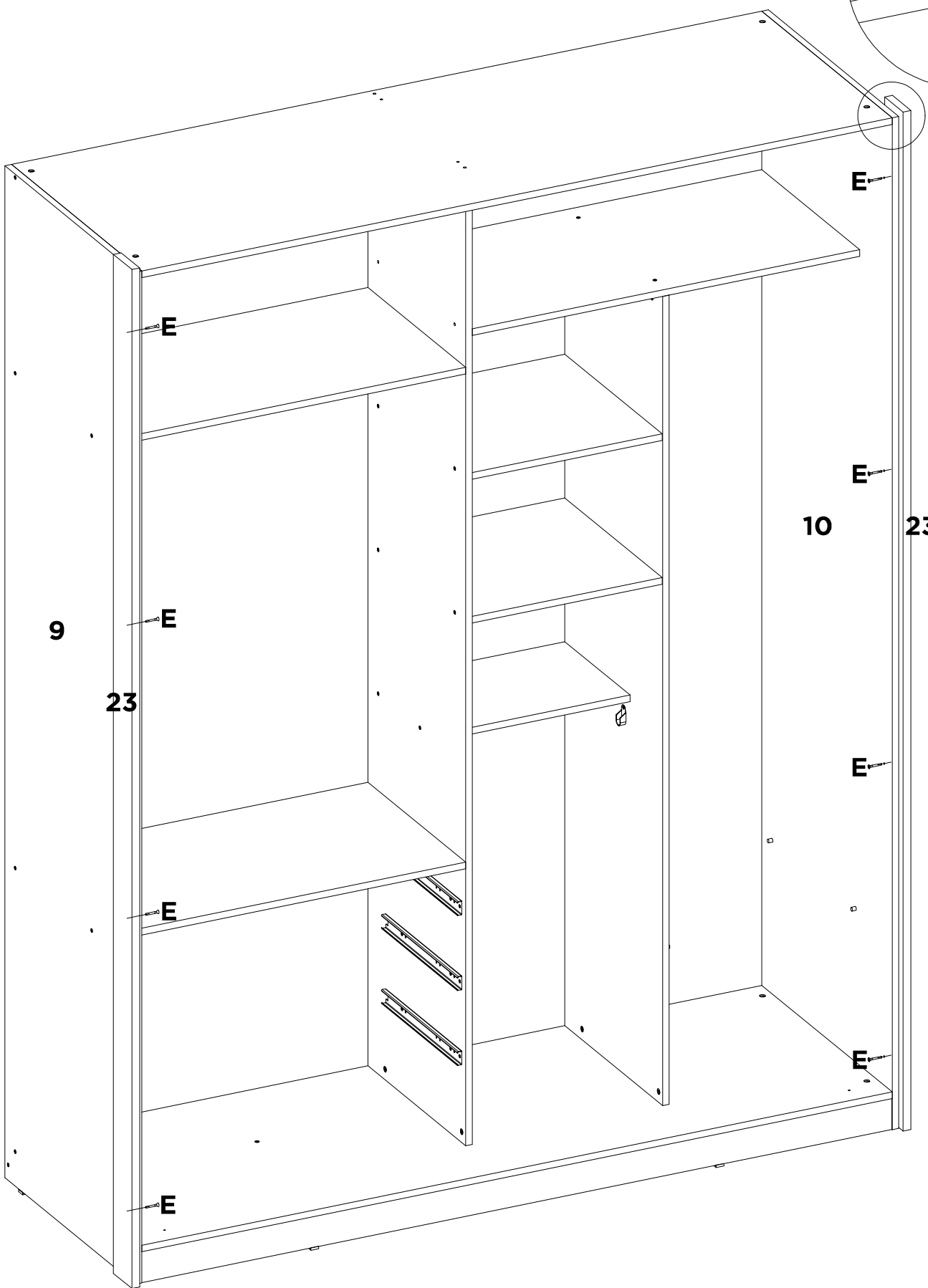
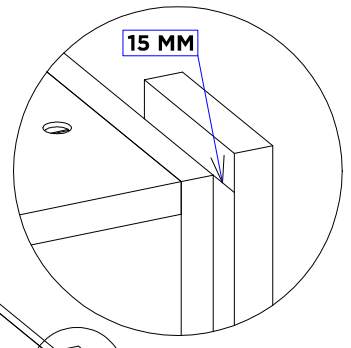

E	-	-	-	-	-	-	-	-
X8	-	-	-	-	-	-	-	-

26

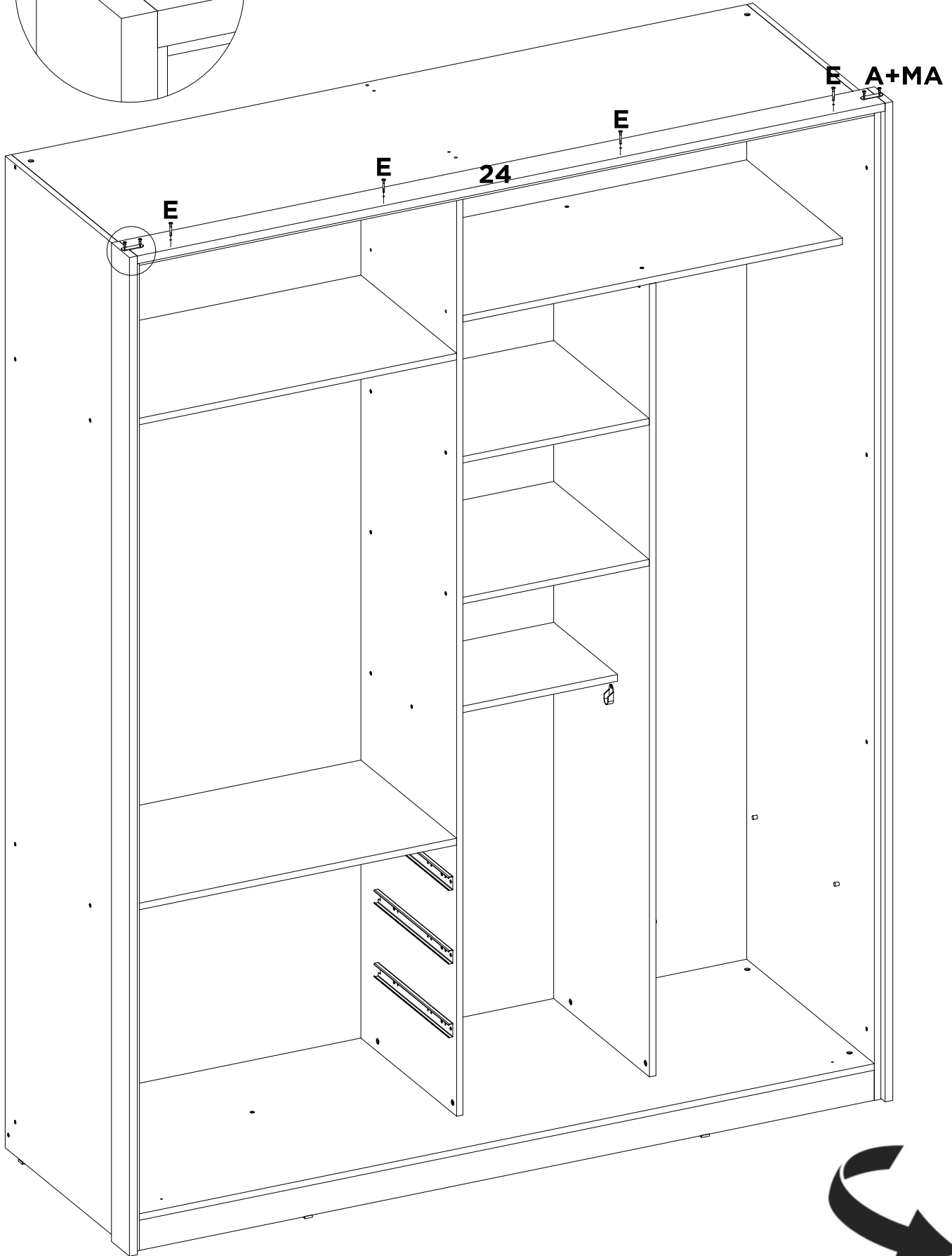
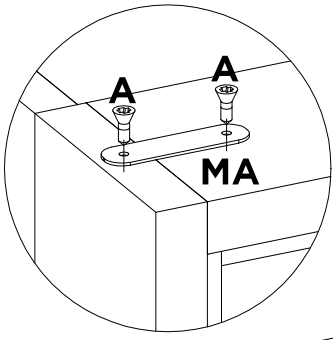

A	E	MA	-	-	-	-	-
X4	X4	X2	-	-	-	-	-

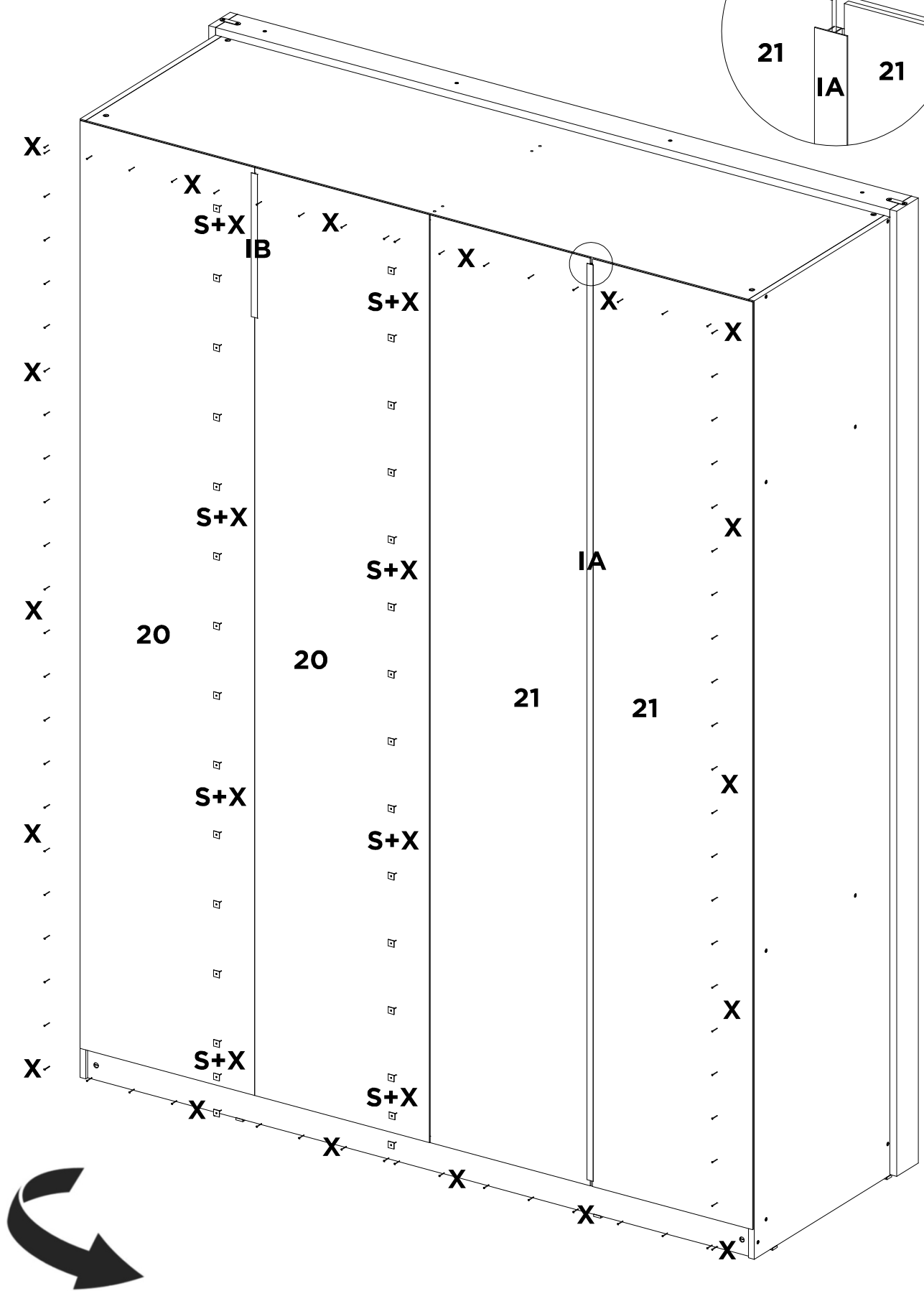
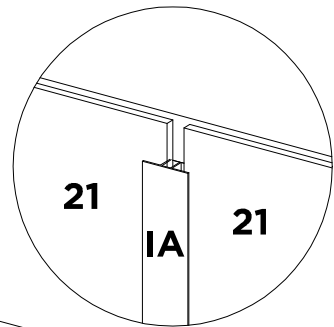

IA	IB	S	X	-	-	-	-
X1	X1	X30	X140	-	-	-	-

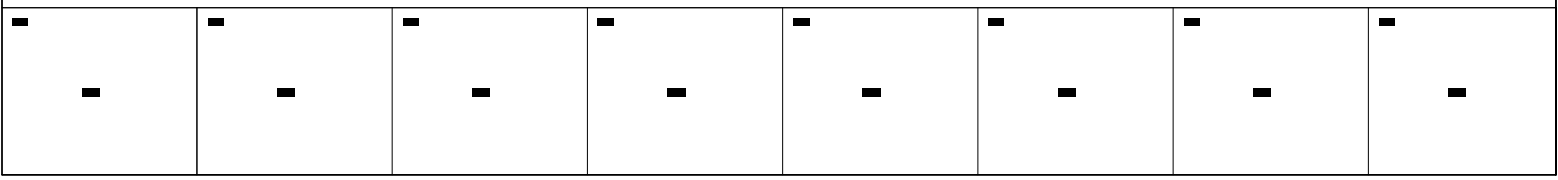
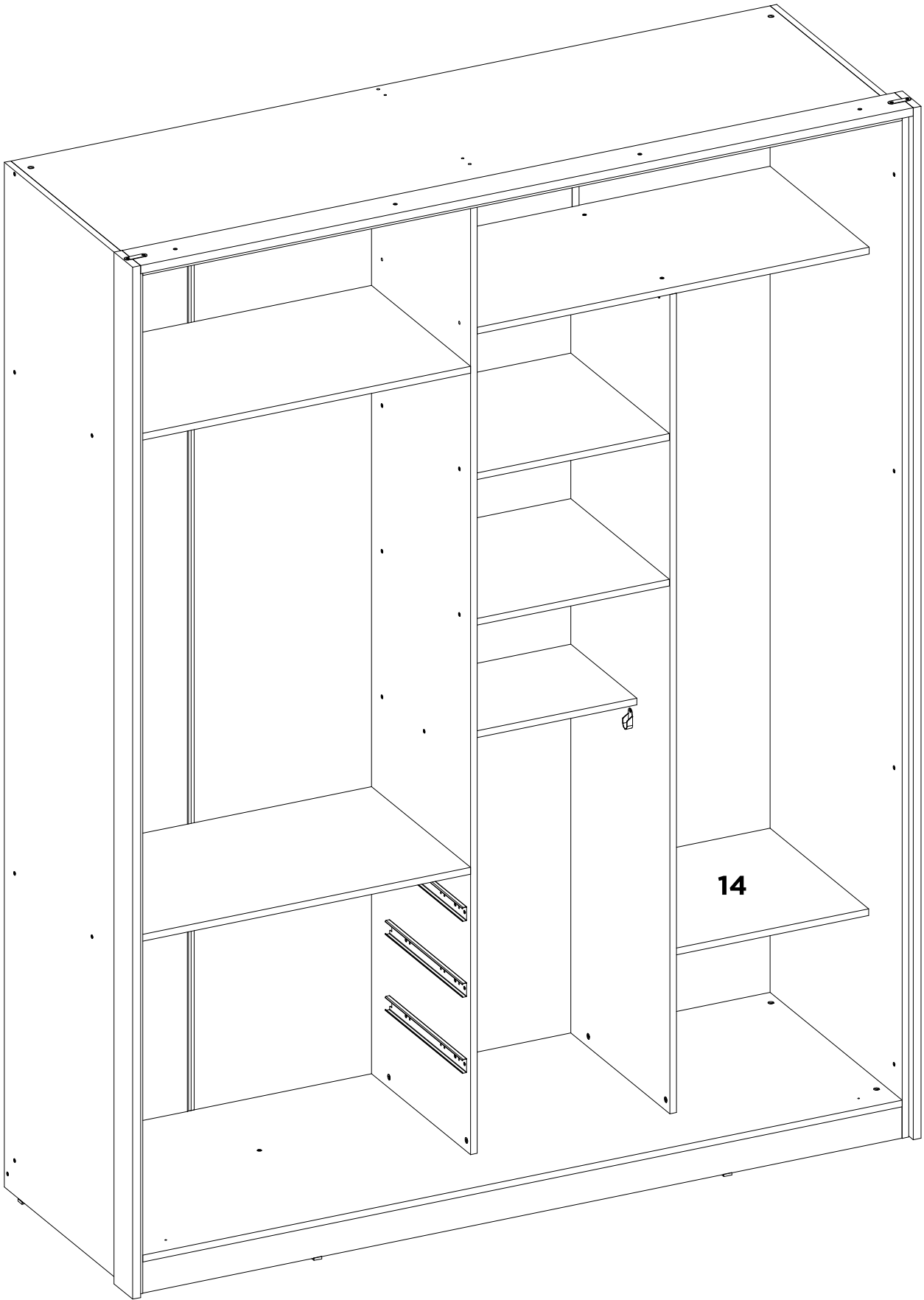

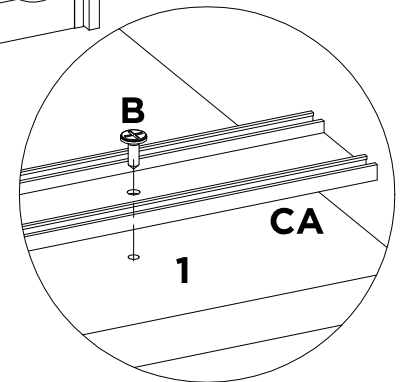
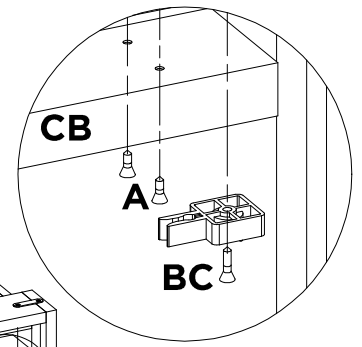
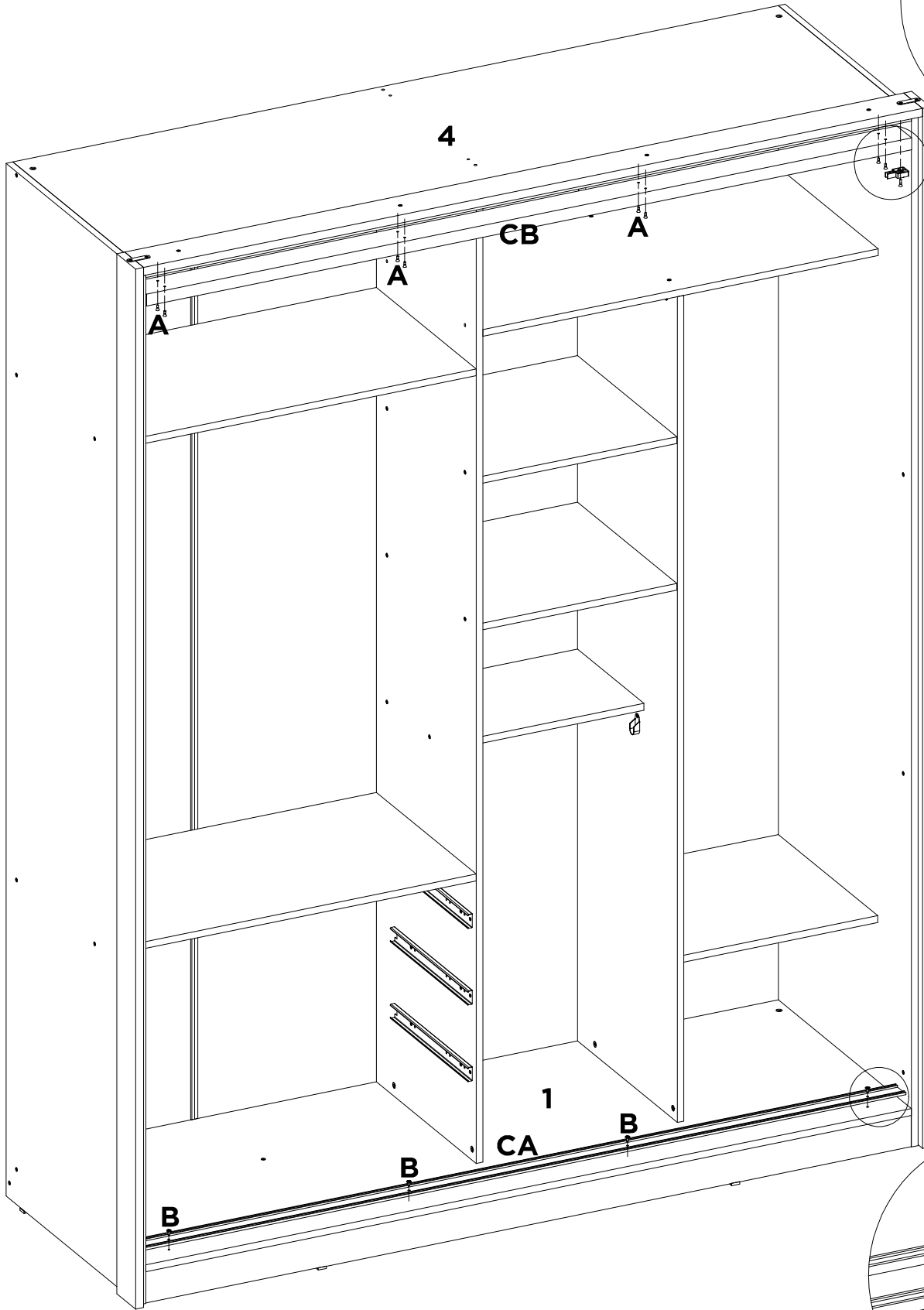

A	B	CA	CB	BC	-	-	-
X8	X4	X1	X1	X2	-	-	-

30

3x

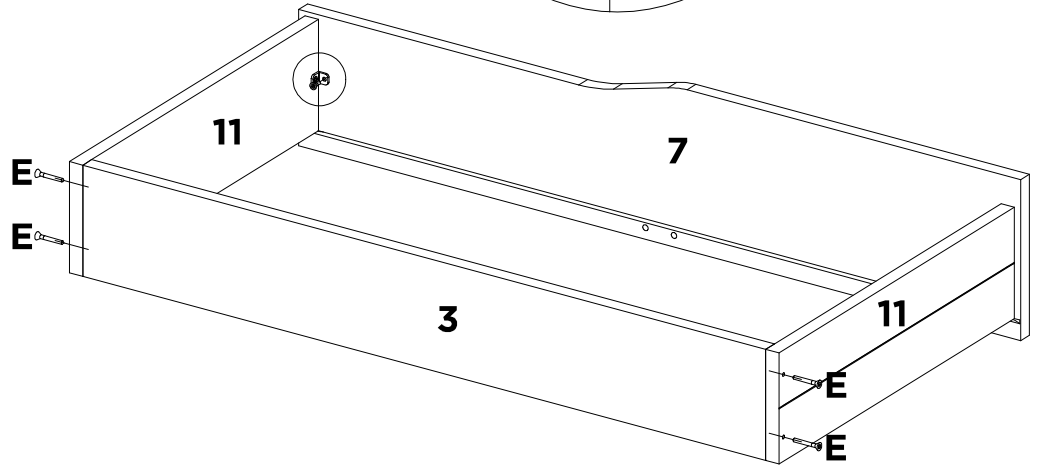
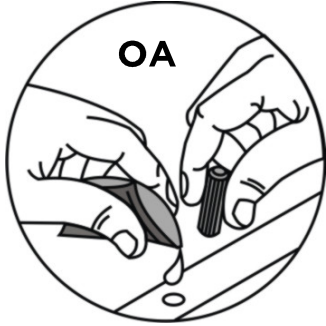
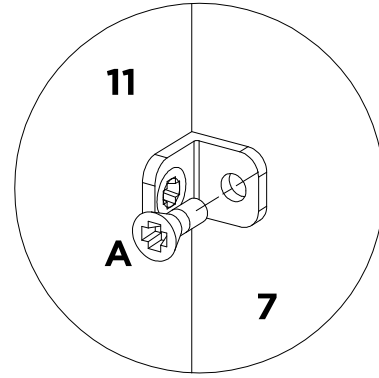
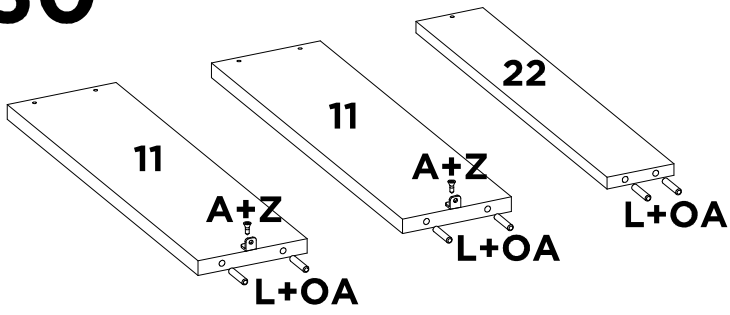

A	E	L	OA	Z	-	-	-
X12	X12	X18	X2	X6	-	-	-

30A

3x

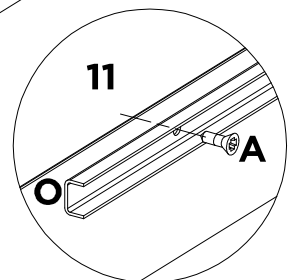
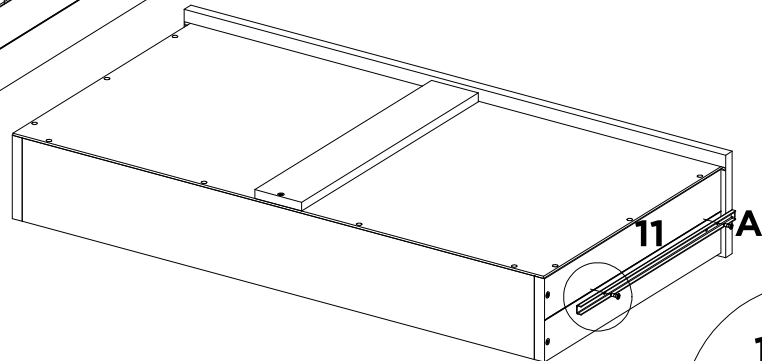
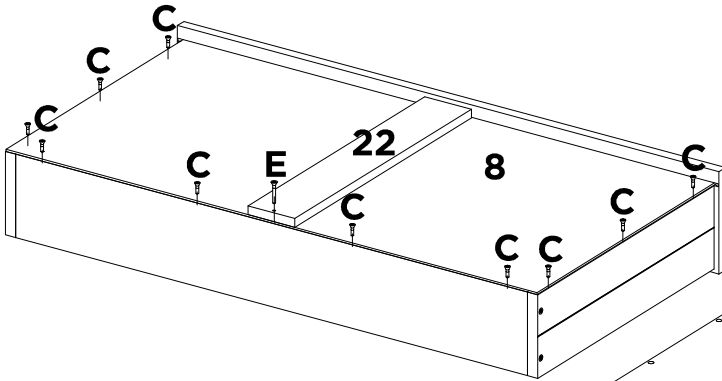

A	C	E	O	-	-	-	-
X12	X30	X3	X6	-	-	-	-

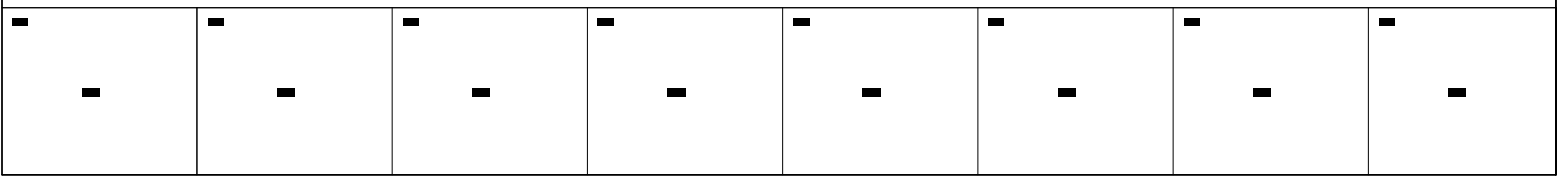
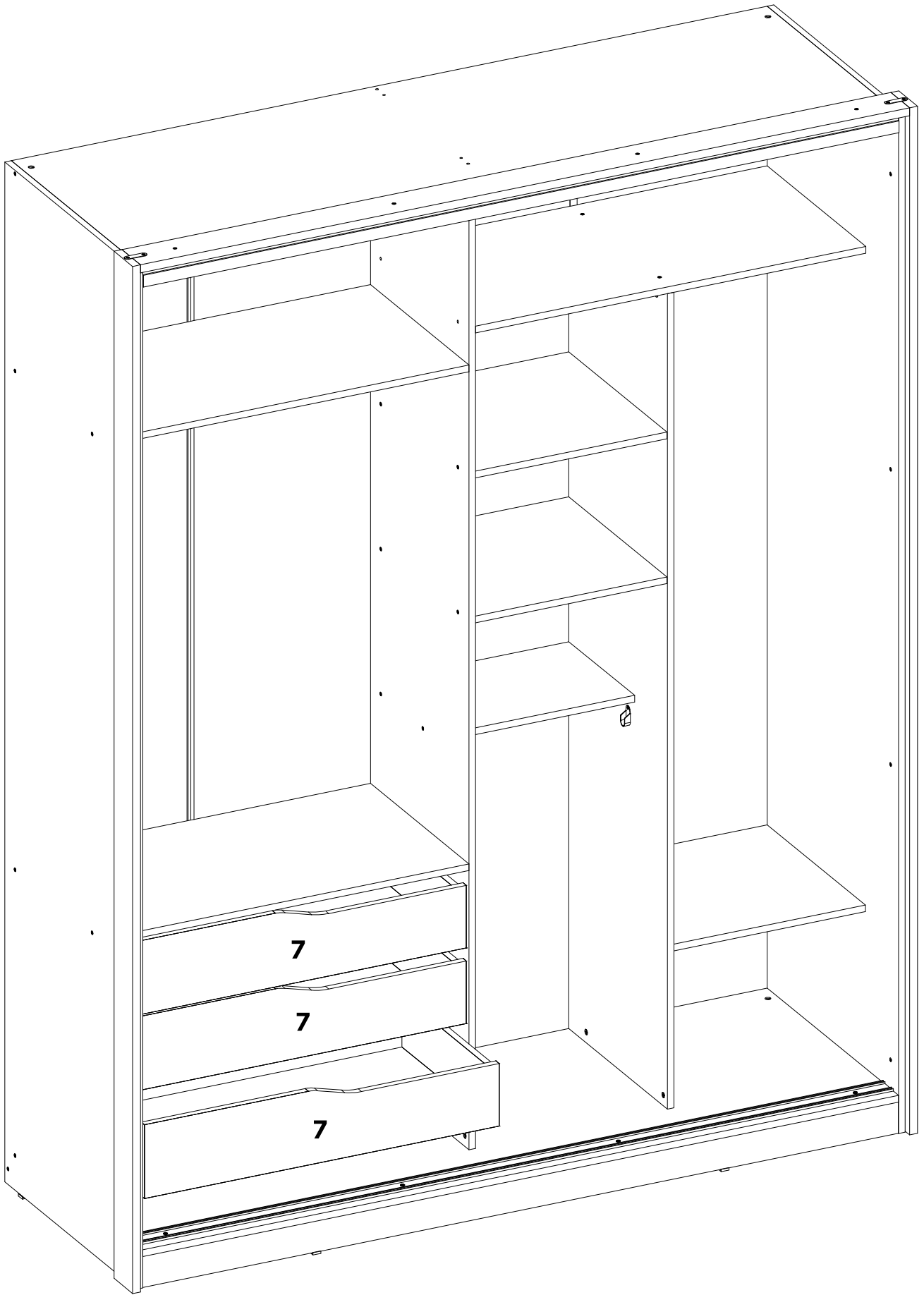

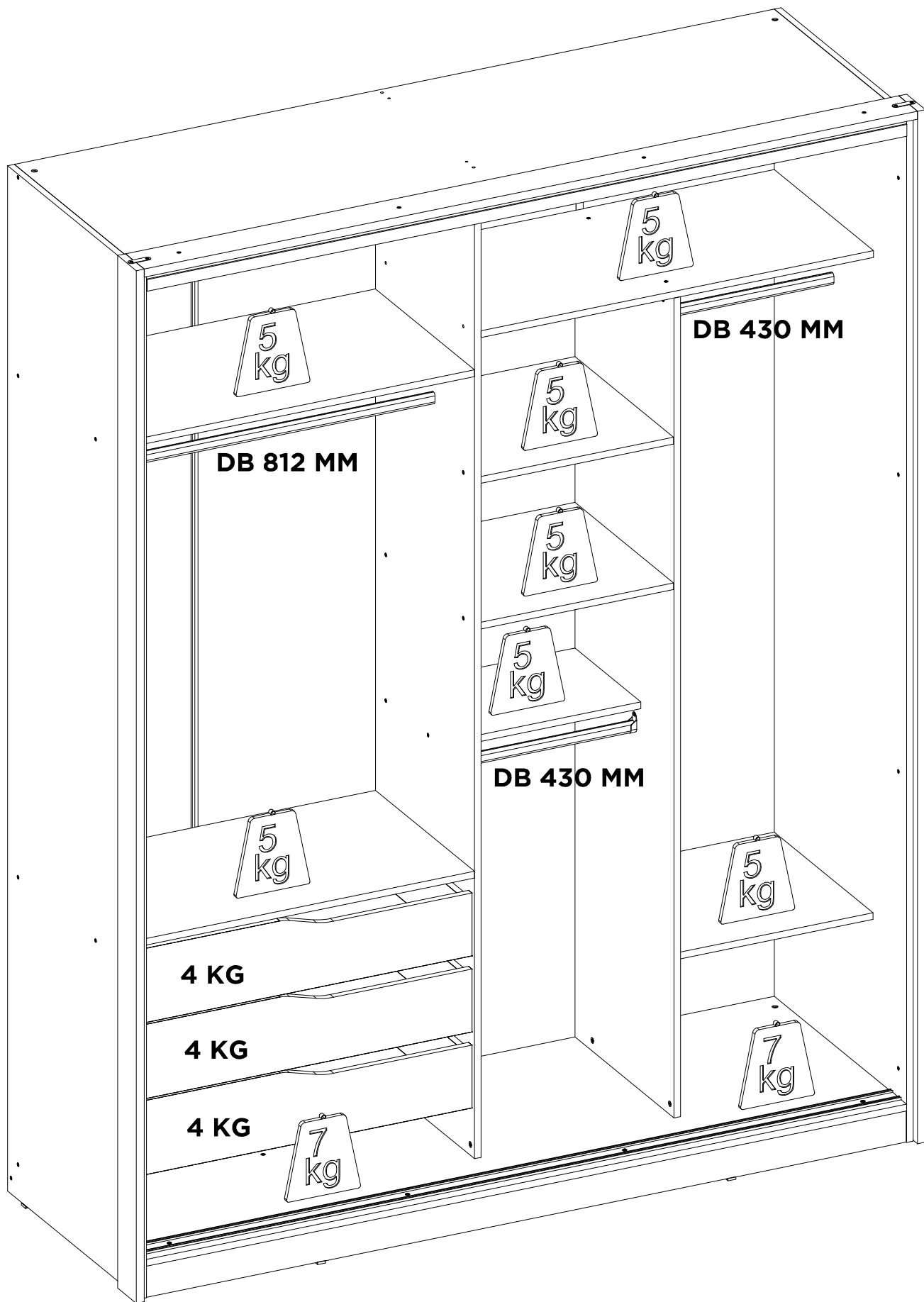

DB 812 MM	DB 430 MM	-	-	-	-	-
X1	X2	-	-	-	-	-

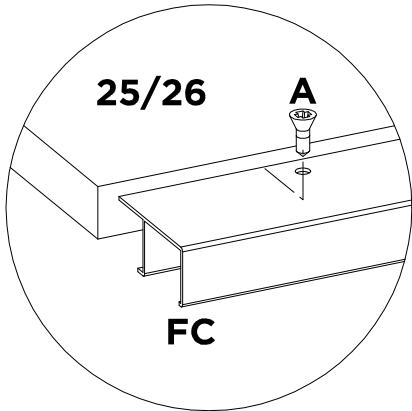
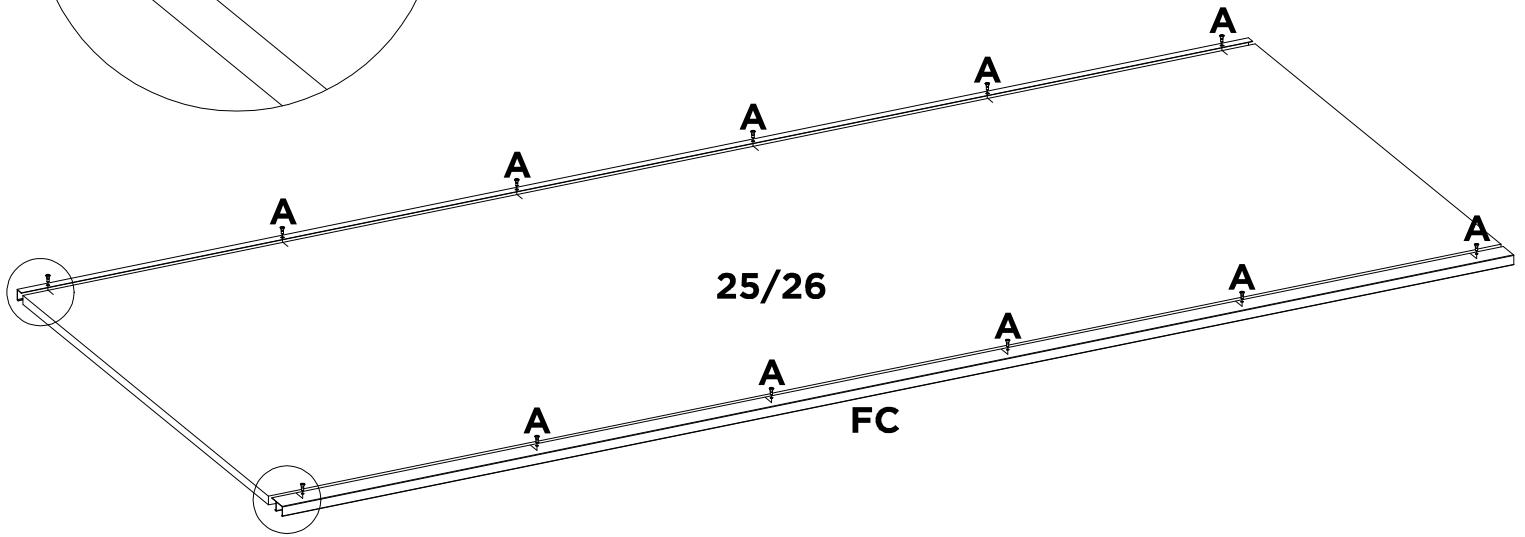
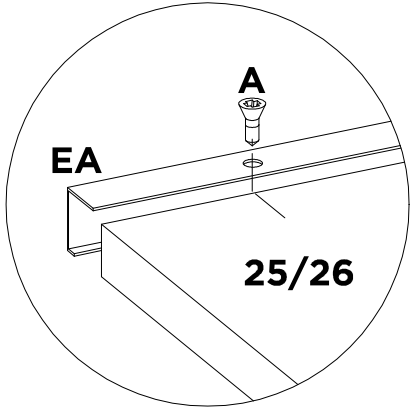

A	EA	FC	-	-	-	-	-
X24	X2	X2	-	-	-	-	-

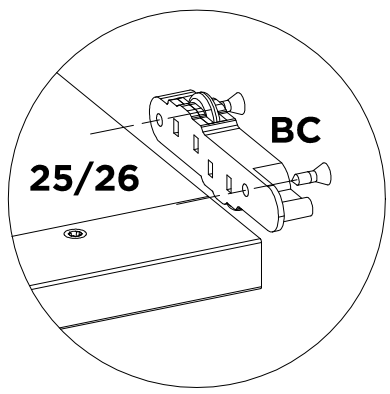
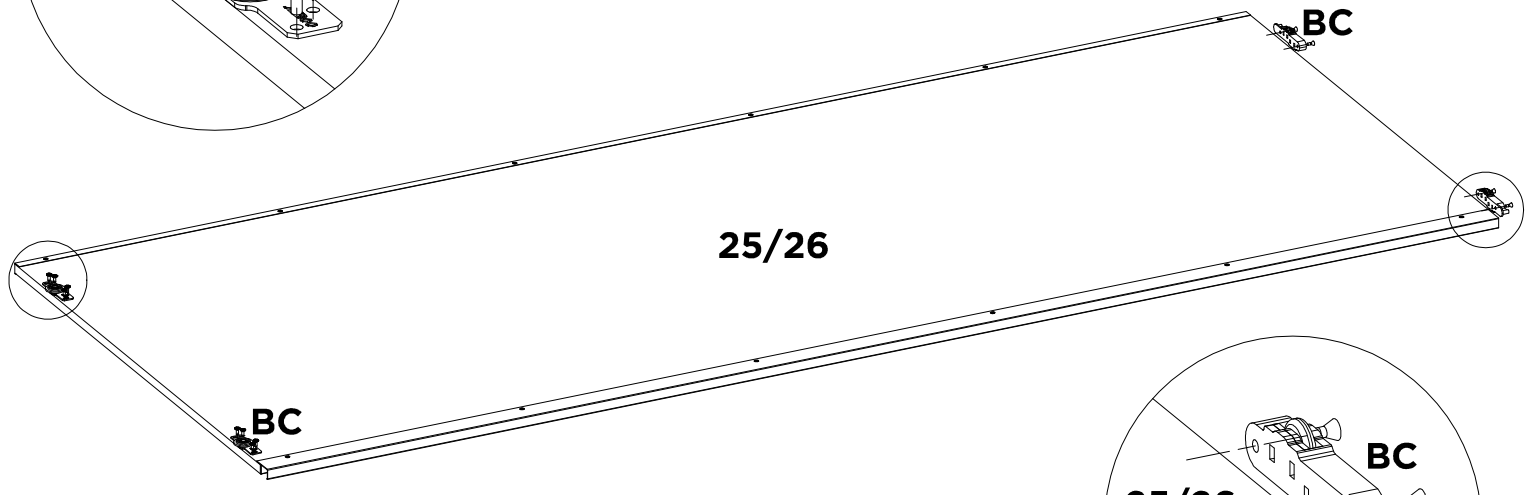
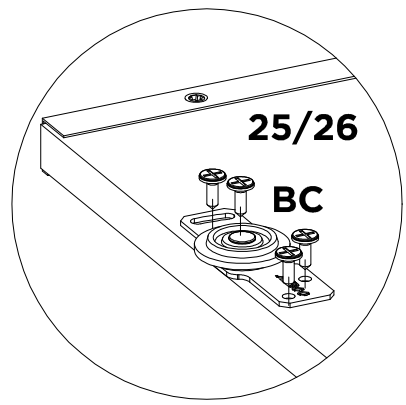

BC	-	-	-	-	-	-	-
X8	-	-	-	-	-	-	-

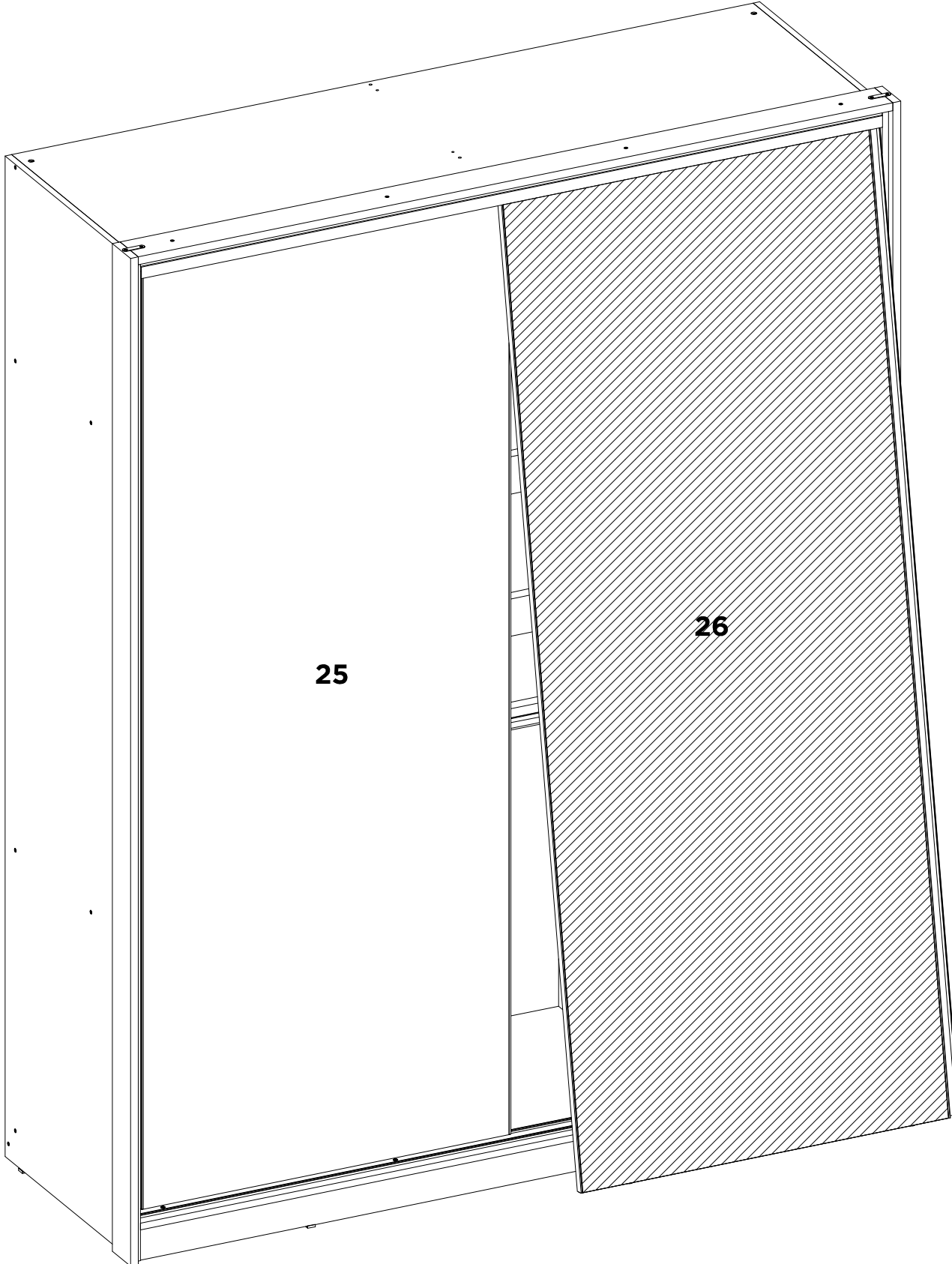

■	■	■	■	■	■	■	■
■	■	■	■	■	■	■	■

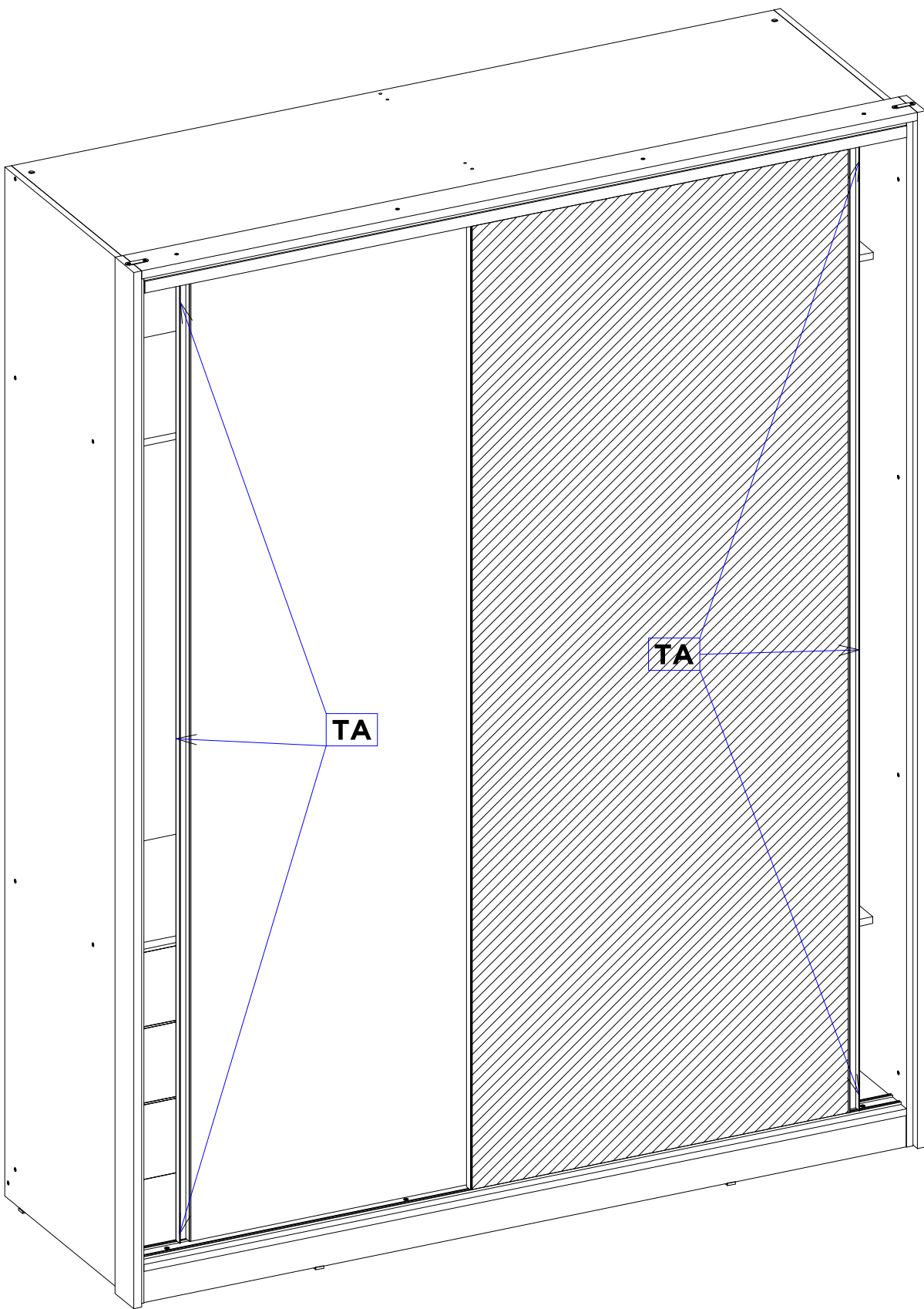

TA	TB	-	-	-	-	-	-
X1	X1	-	-	-	-	-	-

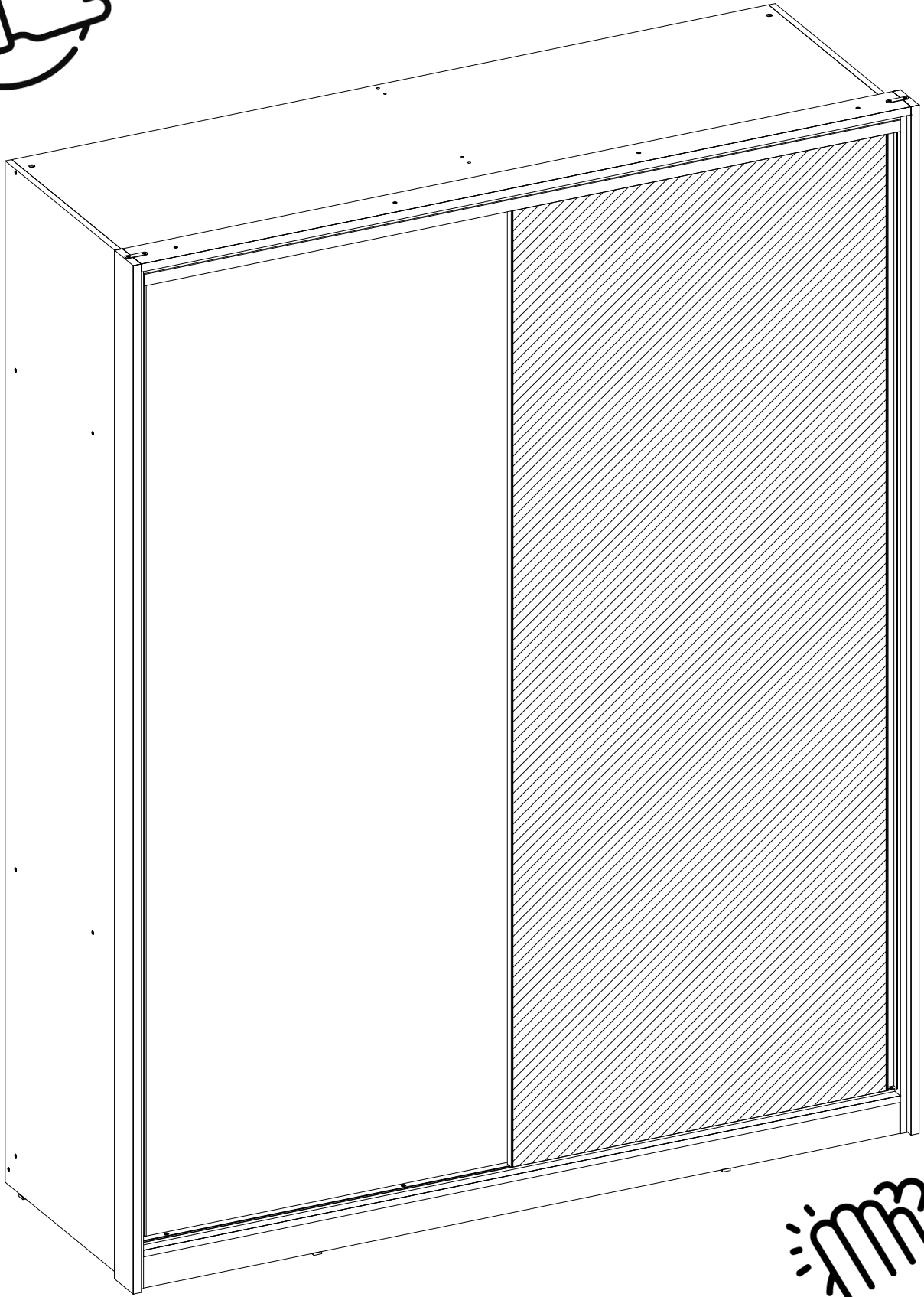

-	-	-	-	-	-	-	-
---	---	---	---	---	---	---	---

DEMARTÊZ

mobília