

HENN

Ind. e Com. de Móveis Henn
Mondaí - SC - Brasil

+55 49 3674.3500

@moveishenn
www.henn.com.br

INSTRUÇÕES DE MONTAGEM

INSTRUCCIONES DE MONTAJE
ASSEMBLY INSTRUCTIONS

Roupeiro Americano 06 Portas | Armario Americano 06 Puertas | Wardrobe Americano 06 Doors

D205-05 Branco HP
D205-23 Duna
D205-90 Grafite HP
D205-106 Rústico/Off White

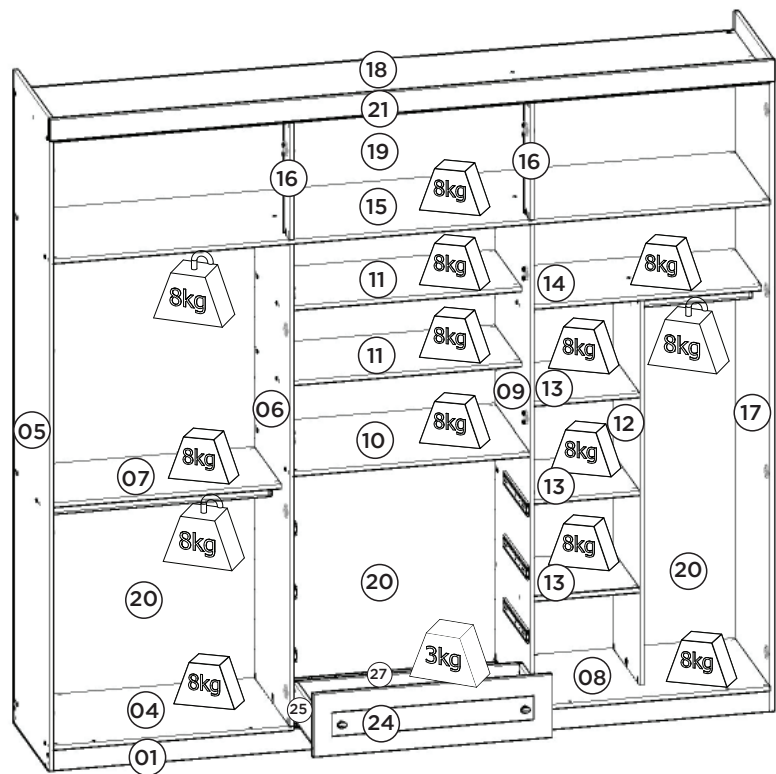
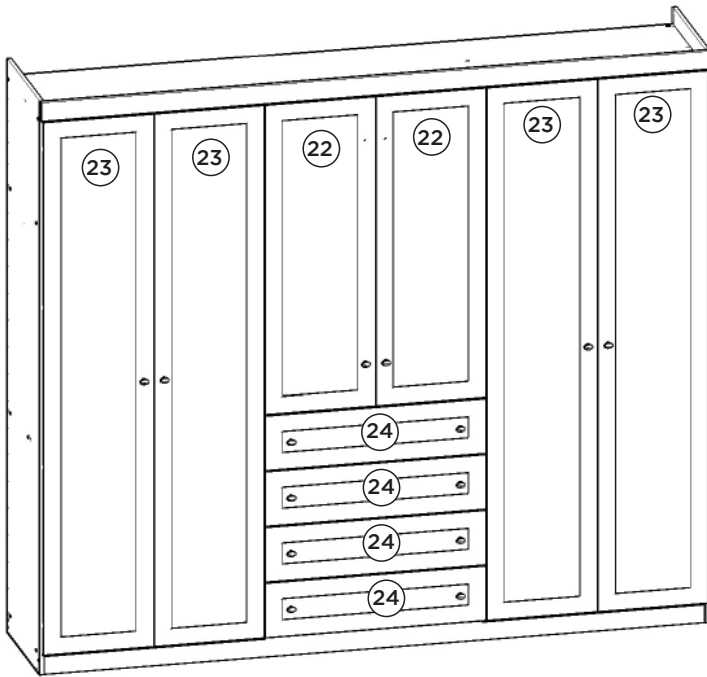

Pesos máximos recomendados com carga distribuída.
Peso máximo recomendado con la carga distribuida.
Recommended maximum weights with evenly distributed.

Requisitos para montagem Requisitor para la montaje Assembly Requirements

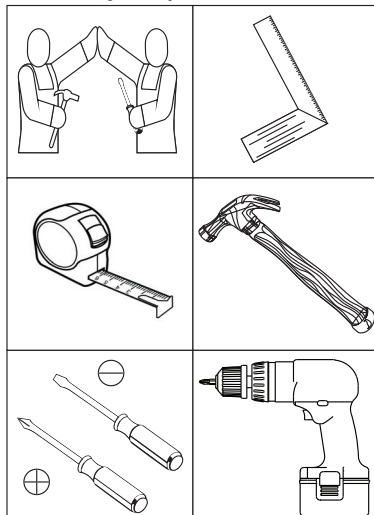

Imagens meramente ilustrativas
Imágenes meramente ilustrativas
Images for illustration only

AVISO

Para limpeza de seu móvel, use uma flanela seca ou umedecida, e não utilize produtos químicos que possam danificar seu produto.

SISTEMA DE MONTAGEM

O sistema de montagem dos produtos, funciona de acordo com a ordem crescente dos números indicados no desenho. Ex: 01, 02, 03, 04... até a conclusão da montagem.

ADVERTENCIA

Para limpieza de su móvil, use una flanela seca o húmeda, y no utilice productos químicos que puedan dañar su producto.

SISTEMA DE MONTAJE

El sistema de montaje de los productos funciona de acuerdo con el orden creciente de los números indicados en el dibujo. Ej.: 01, 02, 03, 04... hasta la conclusión del montaje.

NOTICE

To clean your furniture, use a dry or wet cloth, and do not use chemicals that may damage your product.

ASSEMBLY SYSTEM

The products' assembly system works according to the increasing order of the indicated numbers. For example: 01, 02, 03, 04 ... to the end of the assembly.

1º

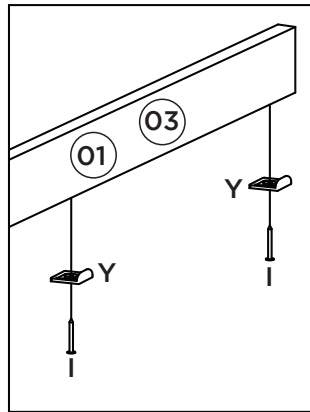
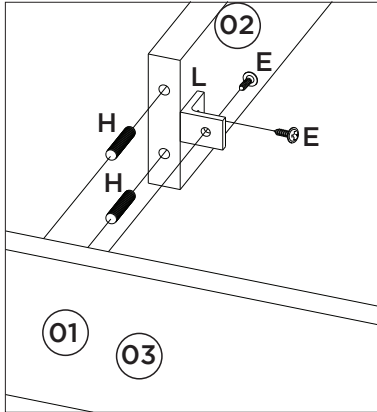
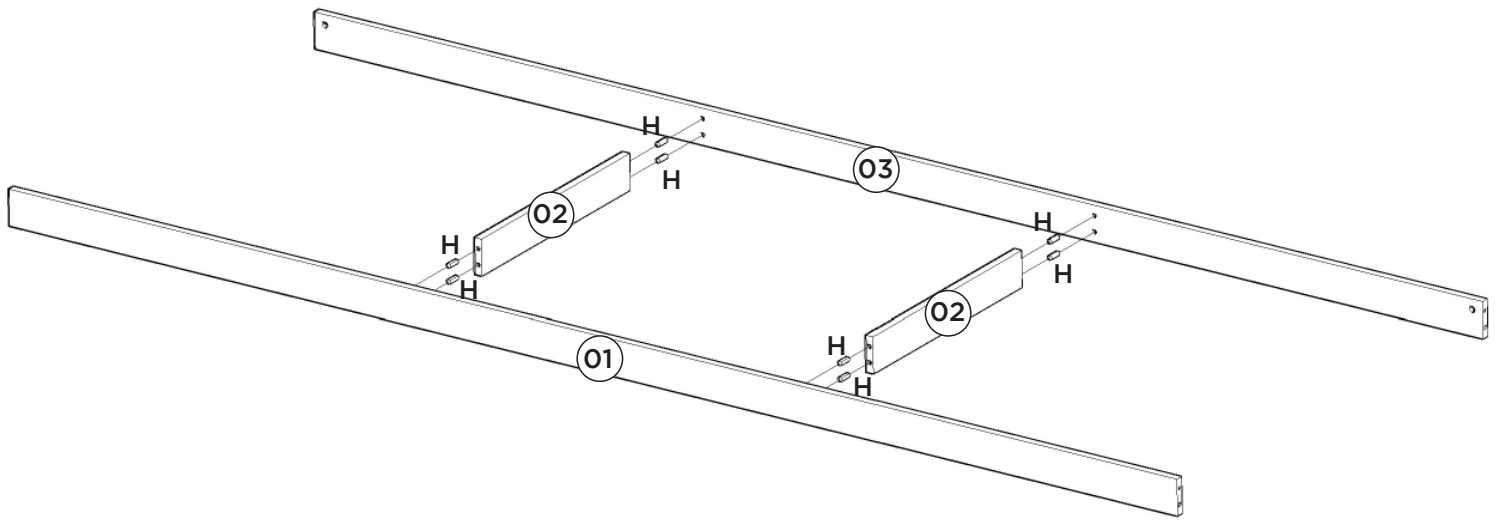

2º

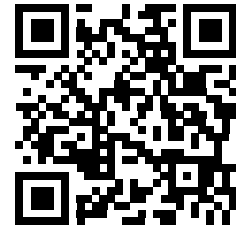

Vídeo: Dicas para fixar o Minifix

Video: Consejos para arreglar Minifix

Video: Tips for Fixing Minifix

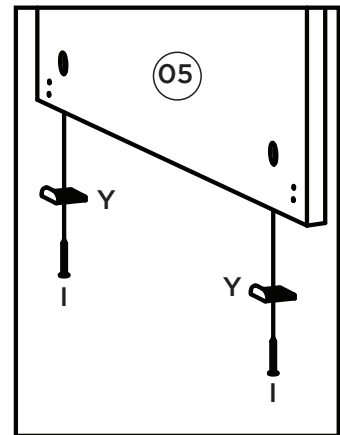
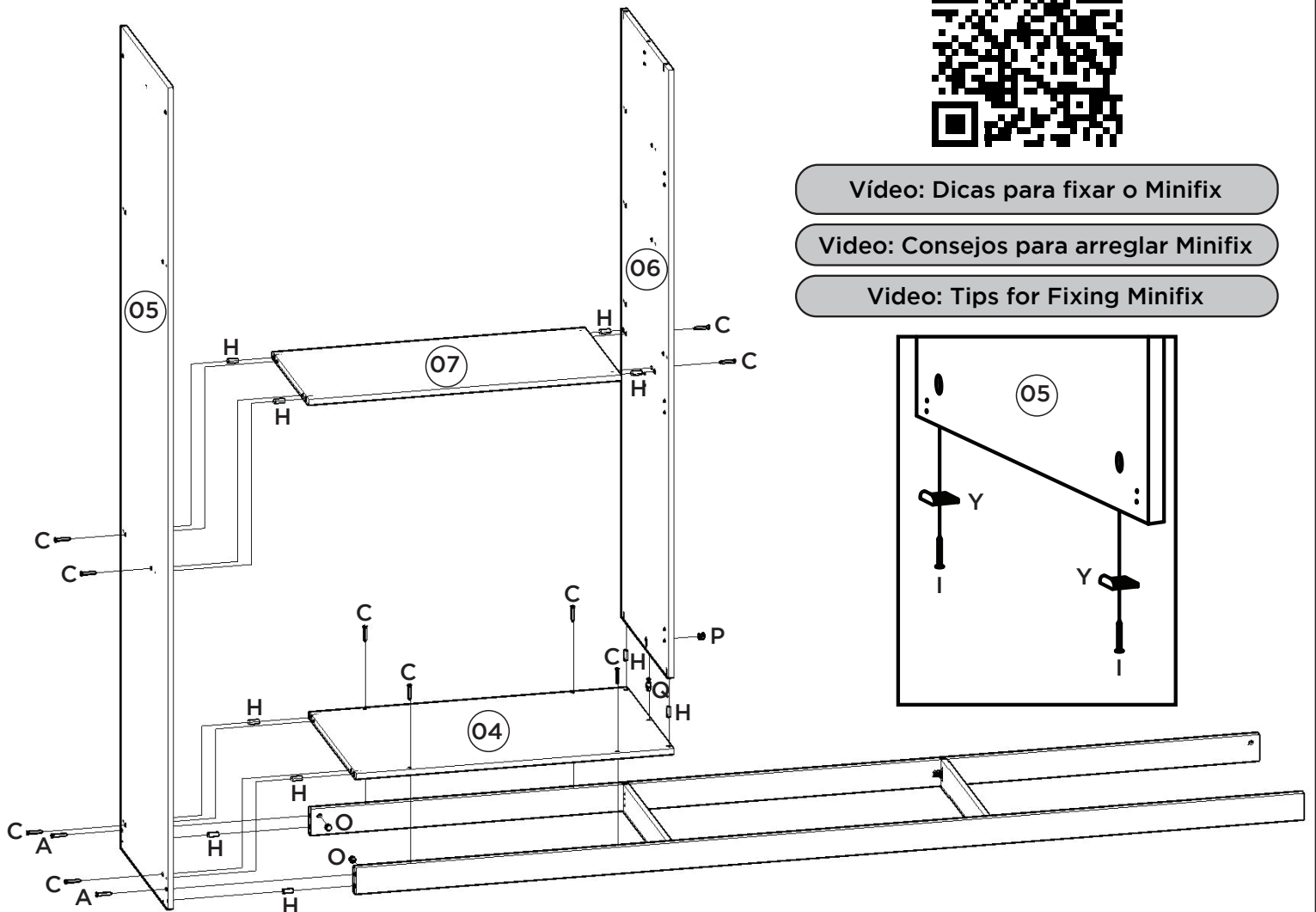

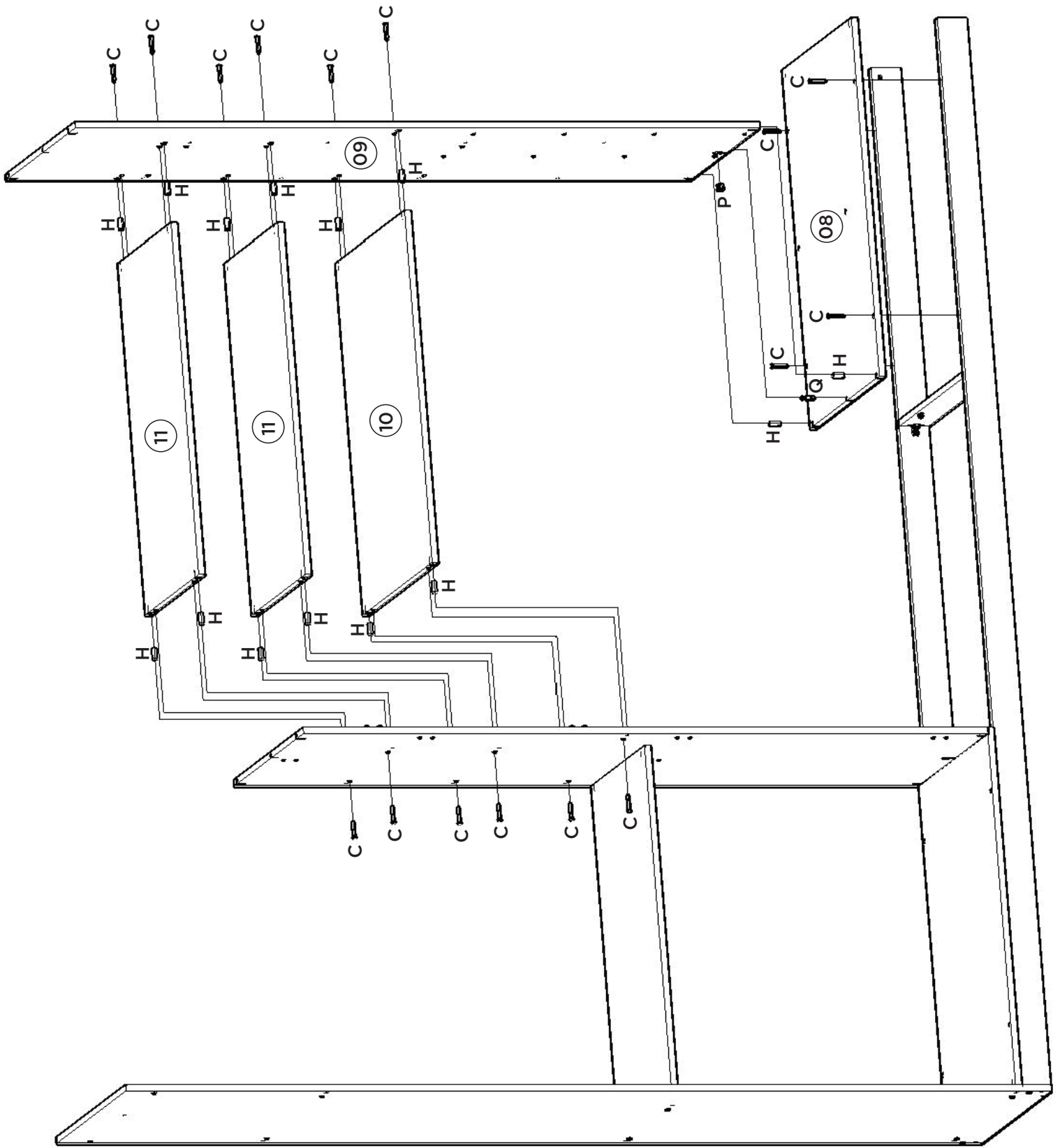

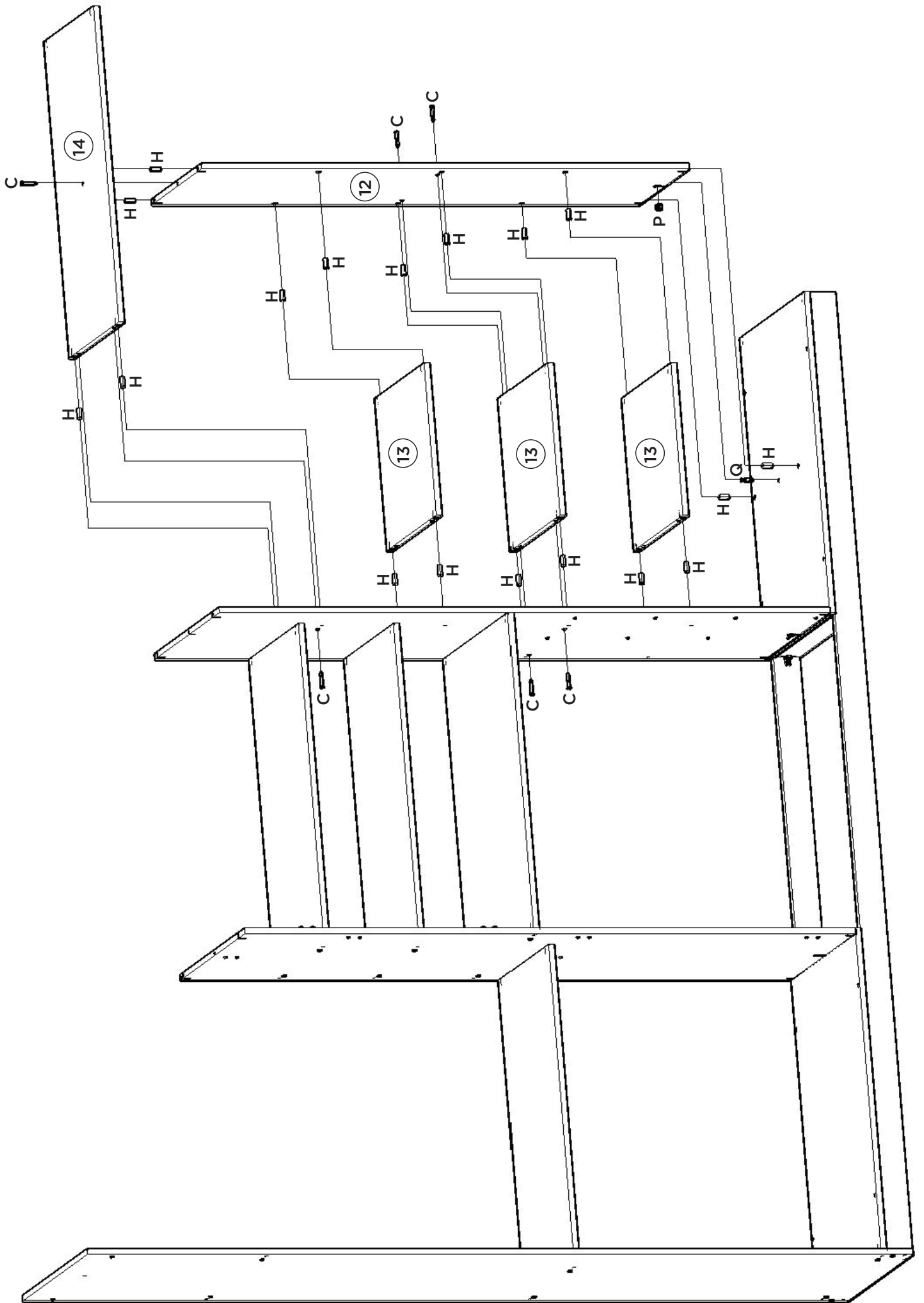

5°

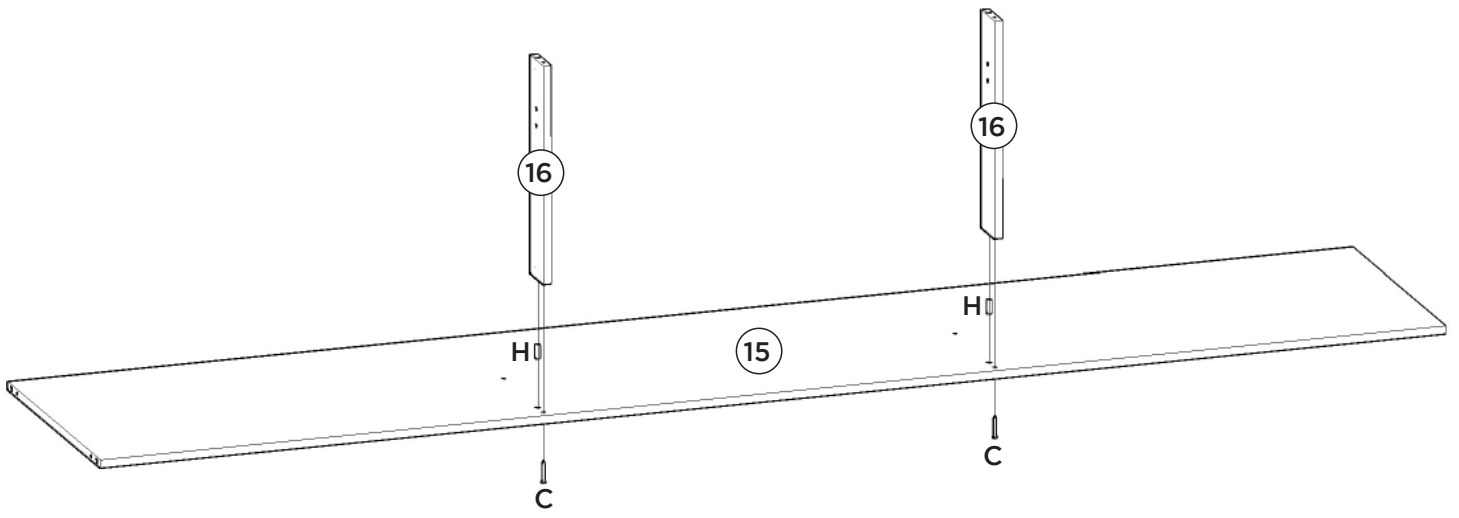

6°

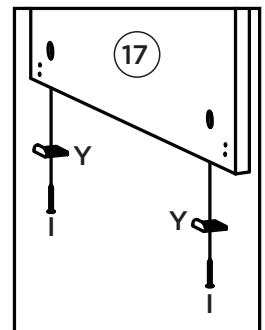
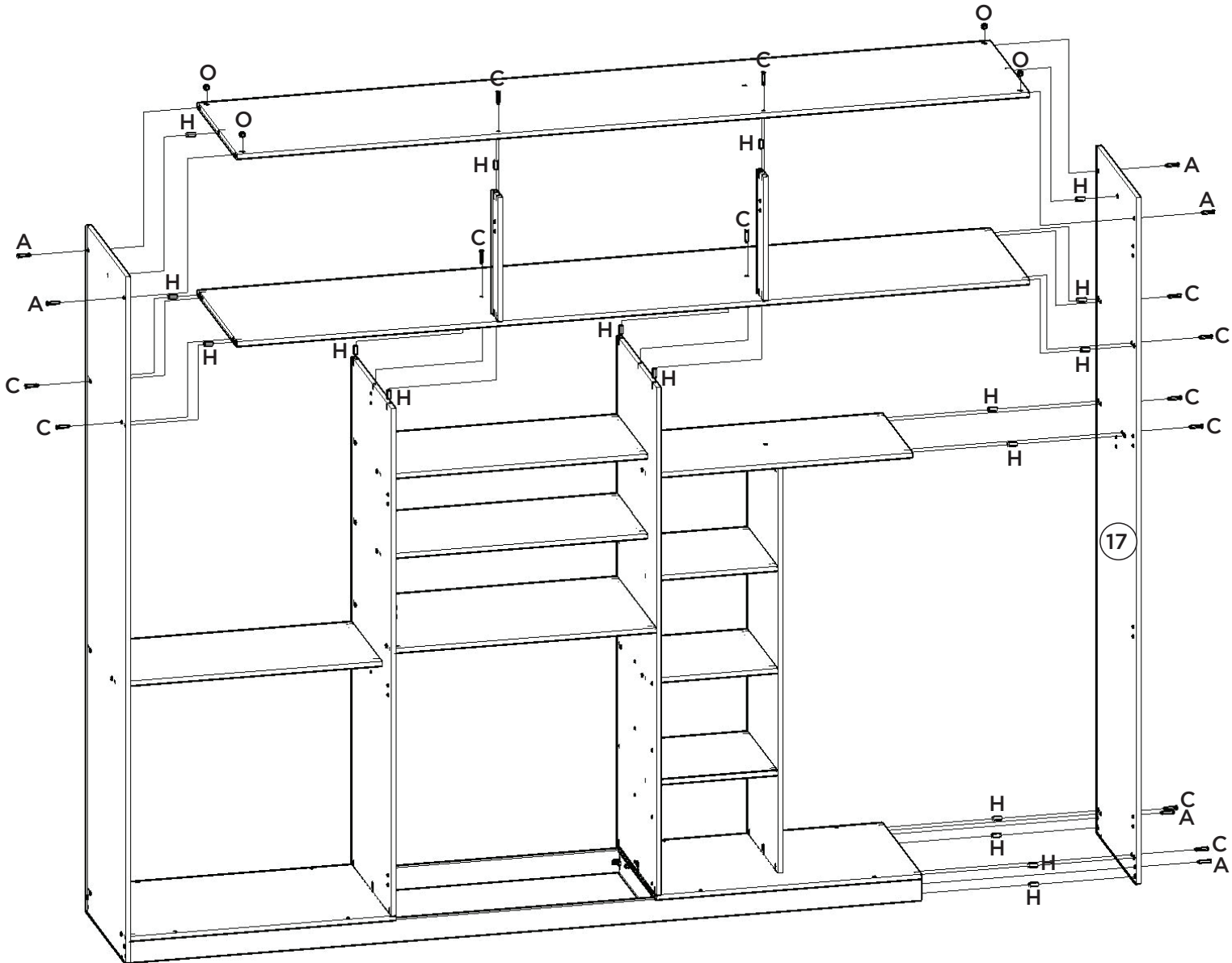

7º

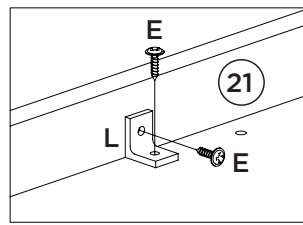
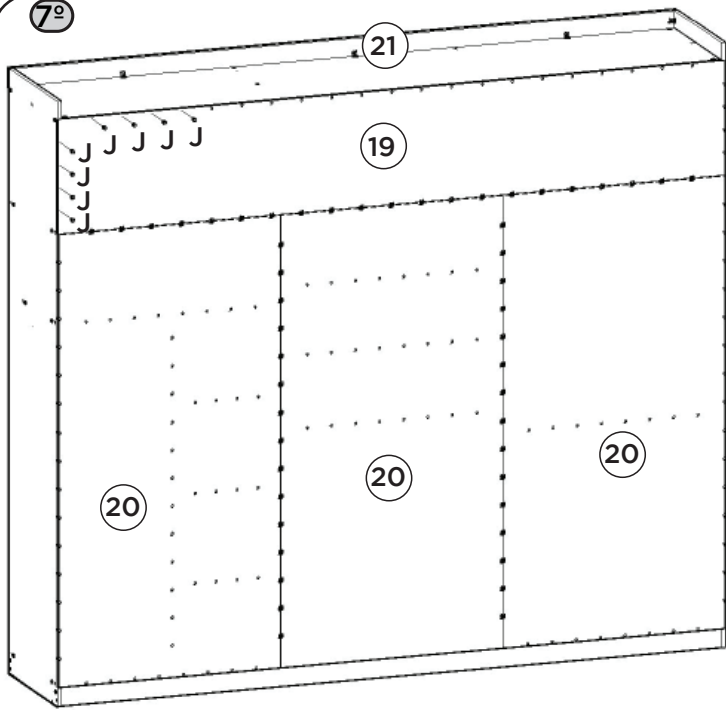

Fixar os pregos a 100mm de distância de um para outro.

Fijar las uñas a 100 mm distancia uno de otro.

Fix the nails 100mm apart from one another.

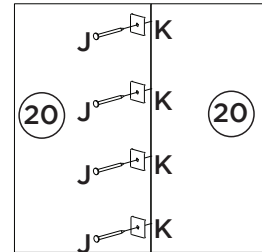
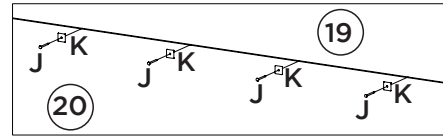

8º

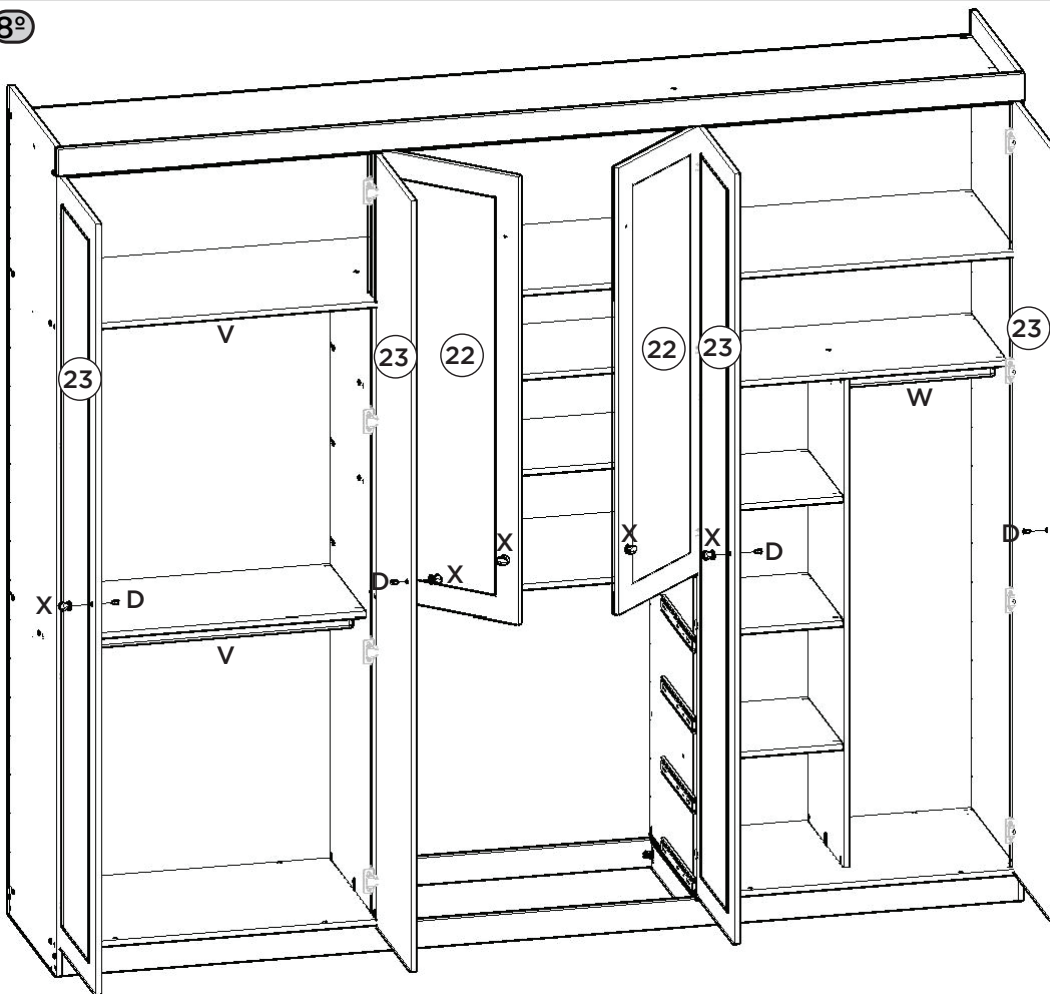

Video: Instalar e regular Dobradiças

Video: Instale y ajuste las bisagras

Video: Install and adjust hinges

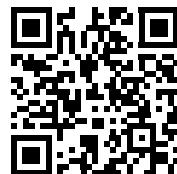
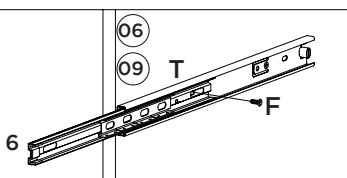
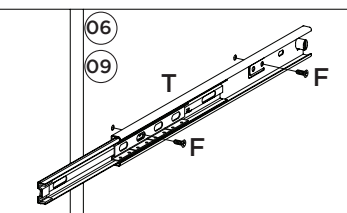
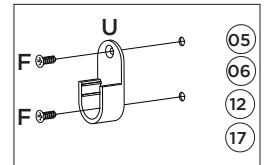
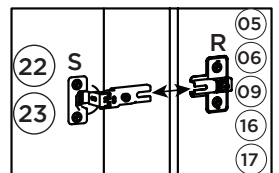
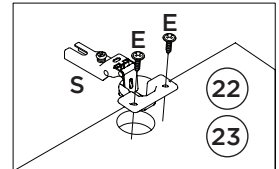
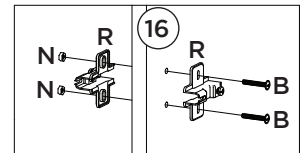
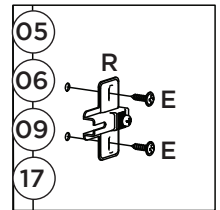
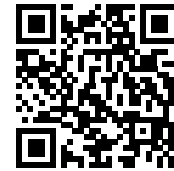

Video: Dicas para fixar a Correção

Video: Consejos para arreglar la diapositiva

Video: Tips for Fixing the Slide

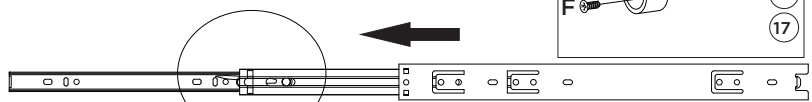

Para a desmontagem da correção siga a instrução ao lado.

Para el desmontaje seguimiento de diapositivas la instrucción siguiente a.

For the dismount of the sliding onem follows the instruction aside.

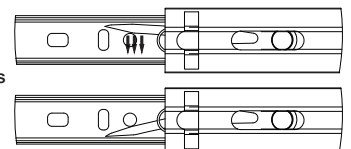

Fixar as correções nessas furações
Fijar las diapositivas de estos agujeros
Fix slides in these drillings

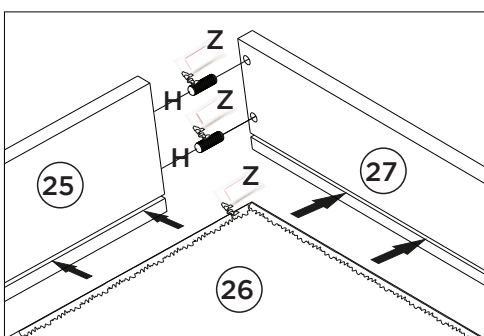
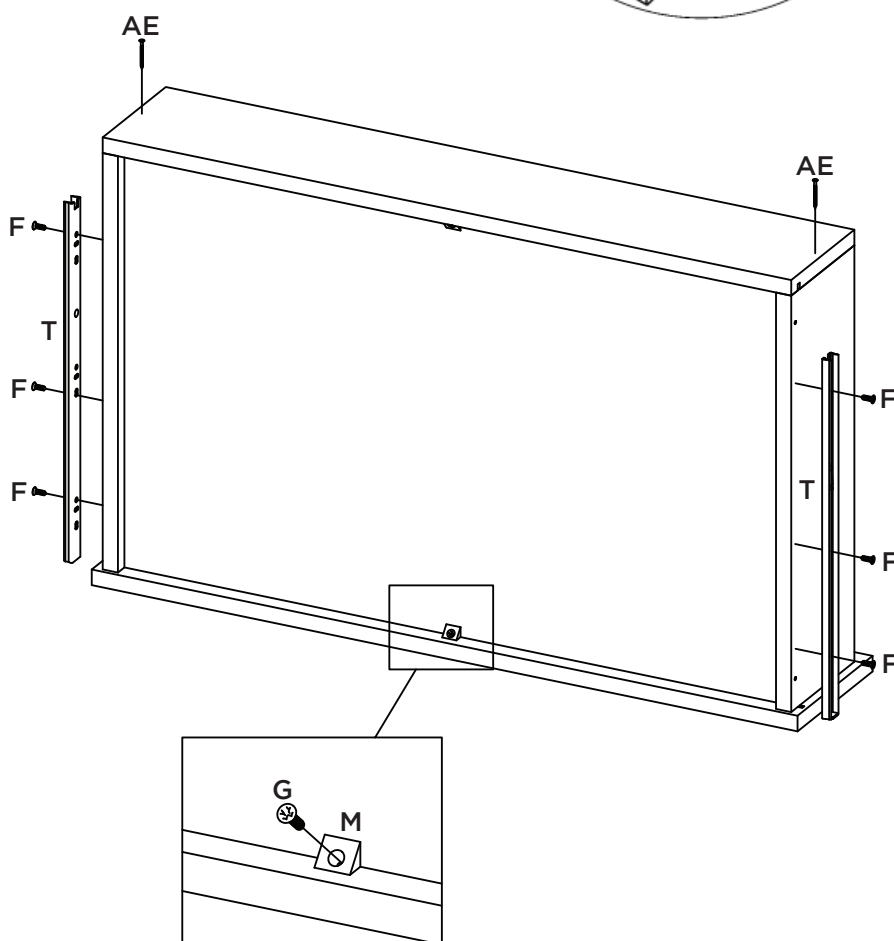
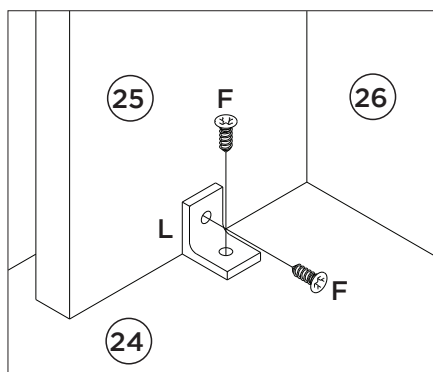
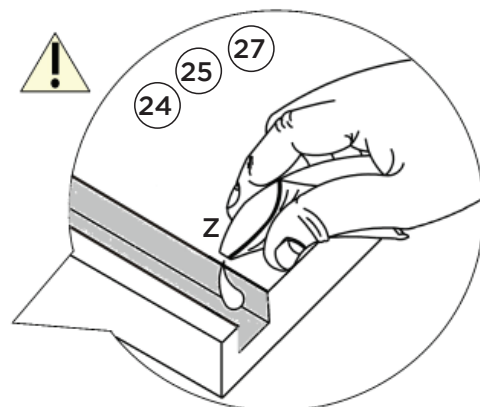
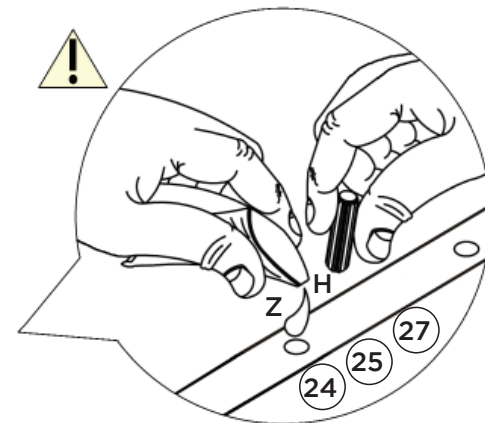
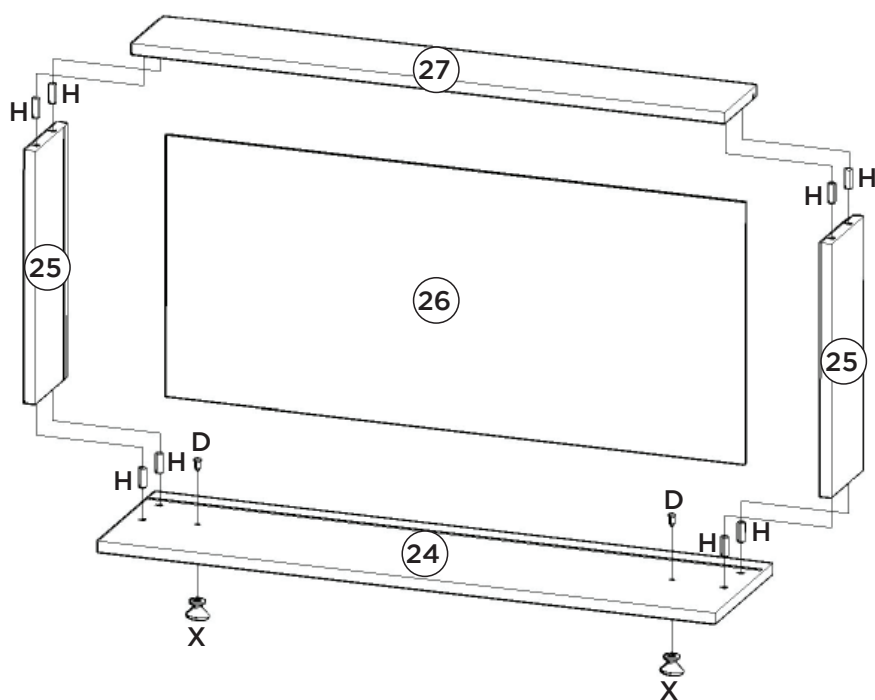

Utilize o sachê de cola (Z) nas cavilhas (H) e nos frisos de gaveta.

Utilice la bolsita de pegamento (Z) los pernos (H) y cajón de friso.

Use the glue sachet (Z) on the pegs (H) and drawer friezes.



















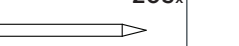
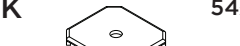

A corrediça (T) deverá ser alinhada com a parte de baixo do lado de gaveta (25).

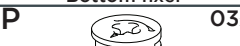
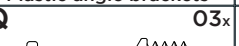
la diapositiva (T) debe estar alineado con la parte inferior del cajón (25).

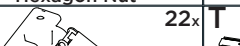
The slide (T) should be aligned with the underside of the drawer side (25).

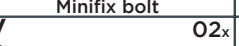
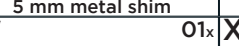
Item	Caixa Caja Box	Qtd Ctd Qty	Descrição Descripción Description	Medidas (mm) Dimensions (mm) Size (measurements) (mm)
01	3/6	01	Rodapé Frontal Rodapié Frontal Front baseboard	2589x73x15
02	1/6	02	Travessa do rodapé Carril pie Baseboard crosspiece	484x73x15
03	3/6	01	Rodapé Traseiro Rodapié trasero Rear baseboard	2589x73x15
04	4/6	01	Base Esquerda Base Izquierda Left Base	868x520x15
05	1/6	01	Lateral esquerda Lateral izquierda Left side	2300x520x15
06	2/6	01	Divisão esquerda División de la izquierda Left Division	1700x520x15
07=11	4/6	01	Prateleira Estante Shelf	853x400x15
08	4/6	01	Base Direita Base derecha Right Base	868x520x15
09	2/6	01	Divisão direita División derecha Right Division	1700x520x15
10	1/6	01	Tampo das Gavetas Superfície de cajones Surface of drawers	853x520x15
11=07	5/6	02	Prateleira Estante Shelf	853x400x15
12	1/6	01	Divisão menor División menor Minor division	1357x400x15
13	2/6 e 4/6	03	Prateleira Menor Estante Menor Minor shelf	412x398x15
14	2/6	01	Prateleira da Divisão Estante de la División Division Shelf	853x400x15
15	3/6	01	Chão do Maleiro Piso del Armario de Equipaje Floor of the Maleiro	2589x520x15
16	1/6	02	Ripa do Maleiro Listón del Armario de Equipaje Clapboard luggage locker	414x73x15
17	1/6	01	Lateral direita Lateral derecha Right side	2300x520x15
18	3/6	01	Tampo Tapa Top	2589x73x15
19	3/6	01	Fundo Superior Fondo Superior Superior background	2613x436x3
20	6/6	03	Fundo Fondo Bottom	1722x869x3
21	3/6	01	Chapéu Sombrero Hat	2617x73x15
22	6/6	02	Porta central Puerta central Central door	1248x430x15
23	5/6 e 6/6	04	Porta Puerta Door	2145x430x15
24	6/6	04	Frente de gaveta Frente de cajón Front of drawer	863x220x15
25	4/6	08	Lado de gaveta Lado del cajón Side of drawer	400x122x15
26	6/6	04	Fundo de gaveta Fondo del cajón Drawer bottom	809x411x3
27	4/6	04	Ripa de trás Malla detrás Rear lath	828x122x15

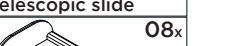
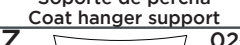
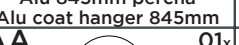
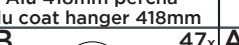
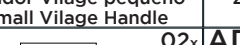
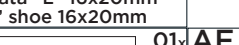
Ferragens | Herrajes | Hardware

A  08x Parafuso 4,5x50mm CHT. Tornillo 4,5x50mm CHT. Screw 4,5x50mm CHT.	B  04x Parafuso 4,0x25mm FLA. Tornillo 4,0x25mm FLA. Screw 4,0x25mm FLA.	C  47x Parafuso 3,5x40mm CHT. Tornillo 3,5x40mm CHT. Screw 3,5x40mm CHT.	D  14x Parafuso 3,5x25mm FLA. Tornillo 3,5x25mm FLA. Screw 3,5x25mm FLA.	E  98x Parafuso 3,5x14mm FLA. Tornillo 3,5x14mm FLA. Screw 3,5x14mm FLA.
F  76x Parafuso 3,5x12mm CHT. Tornillo 3,5x12mm CHT. Screw 3,5x12mm CHT.	G  08x Parafuso 3,0x16mm CHT. Tornillo 3,0x16mm CHT. Screw 3,0x16mm CHT.	H  102x Cavilha 8x25mm Cinta 8x25mm Dowel 8x25mm	I  08x Prego 12x12mm Anelado Clavo 12x12mm Anillado Ringed Nails 12x12mm	J  203x Prego 10x10mm Clavo 10x10mm Nail 10x10mm
K  54x Fixador de fundos Fijador de fondos Bottom fixer	L  17x Cantoneira plástica Cantonera plástica Plastic angle brackets	M  08x Cantoneira suporte triangular Cantonera soporte triangular Triangle support angle	N  04x Porca Sextavada Tuerca Hexagonal Hexagon Nut	O  08x Porca cilíndrica Tuerca cilíndrica Cylindrical nut
P  03x Tambor minifix Tambor minifix Minifix drum	Q  03x Parafuso minifix Tornillo minifix Minifix bolt	R  22x Calço metal 5mm Calzado metálico 5mm 5 mm metal shim	S  22x Dobradiça metal 26mm Bisagra de metal 26mm 26 mm metal hinge	T  04x Corrediça telescópica Corredera telescópica Telescopic slide
U  06x Suporte cabideiro Soporte de percha Coat hanger support	V  02x Cabideiro Alum. 845mm Alu 845mm percha Alu coat hanger 845mm	W  01x Cabideiro Alum. 418mm Alu 418mm percha Alu coat hanger 418mm	X  14x Puxador Vilage pequeno Tirador Vilage pequeno Small Vilage Handle	Y  08x Sapata "L" 16x20mm Zapata "L" 16x20mm "L" shoe 16x20mm
Z  02x Sachê de cola Bolsa de pegamento Glue bag	AA  01x Adesivo tapa parafuso 17mm Adhesivo tapón de tornillo 17mm Bolt cover adhesive 17mm	AB  47x Adesivo tapa parafuso 10mm Adhesivo tapón de tornillo 10mm Bolt cover adhesive 10mm	AC  02x Giz de correção Tiza de corrección Chalk of correction	AD  01x HENN Etiqueta resinada Henn Etiqueta resinada Henn Henn resin label
AE  08x Parafuso 3,0x30mm CHT. Tornillo 3,0x30mm CHT. Screw 3,0x30mm CHT.				