

Item	Caixa Caja Box	Qtd Ctd Qty	Descrição Descripción Description	Medidas (mm) Dimensions (mm) Size (measurements) (mm)
01	2/3	01	Rodapé frontal Rodapié frontal Front footboards	2136x120x12
02	1/3	03	Travessa Rodapé Rodapié Bandeja Footboard Platter	415x120x12
03	2/3	01	Rodapé traseiro Rodapié trasero Rear footboard	2136x120x12
04	2/3	01	Lateral esquerda Lateral izquierda Left side	2100x445x12
05	2/3	01	Base Base Base	2136x445x12
06	1/3	01	Divisão esquerda División izquierda Left division	1880x445x12
07=13	1/3	01	Prateleira Estante Shelf	525x350x12
08	1/3	01	Divisão das Gavetas División de cajones Division of Drawers	720x445x12
09	1/3	01	Tampo da gaveta Tapa del cajón Drawer top	1062x445x12
10	2/3	01	Pilastra Pilastra Pillar	1148x95x12
11	1/3	02	Prateleira Maior Estante Más Grande Larger Shelf	1062x350x12
12	1/3	01	Divisão direita División derecha Right division	1880x445x12
13=07	1/3	01	Prateleira Estante Shelf	525x350x12
14	2/3	01	Tampo Superior Cubierta Superior Top Cover	2136x445x12
15	2/3	01	Lateral direita Lateral derecha Right side	2100x445x12
16	2/3	04	Fundo Fondo Raw	1904x537x3
17	2/3	01	Chapéu Sombrero Hat	2158x80x15
18	3/3	08	Porta Puerta Central	1889x265x15
19	1/3	04	Frente de Gaveta Frente del Cajón Drawer Front	485x190x12
20	1/3	08	Lado de gaveta Lado del cajón Drawer side	350x100x12
21	1/3	04	Ripa de trás Listón trasero Rear batten	450x100x12
22	2/3	04	Fundo de Gaveta Recortado Fondo de cajón recortado Cropped Drawer Background	449x367x3



Ind. e Com. de Móveis Henn
Mondai - SC - Brasil

+55 49 3674.3500

@moveishenn
www.henn.com.br

INSTRUÇÕES DE MONTAGEM

INSTRUCCIONES DE MONTAJE
ASSEMBLY INSTRUCTIONS

Roupeiro 08 Portas / Armario de 08 Puertas / 08 Door Wardrobe

- B51-10 Branco
- B51-127 Nature/Off White
- B51-130 Castanho HP

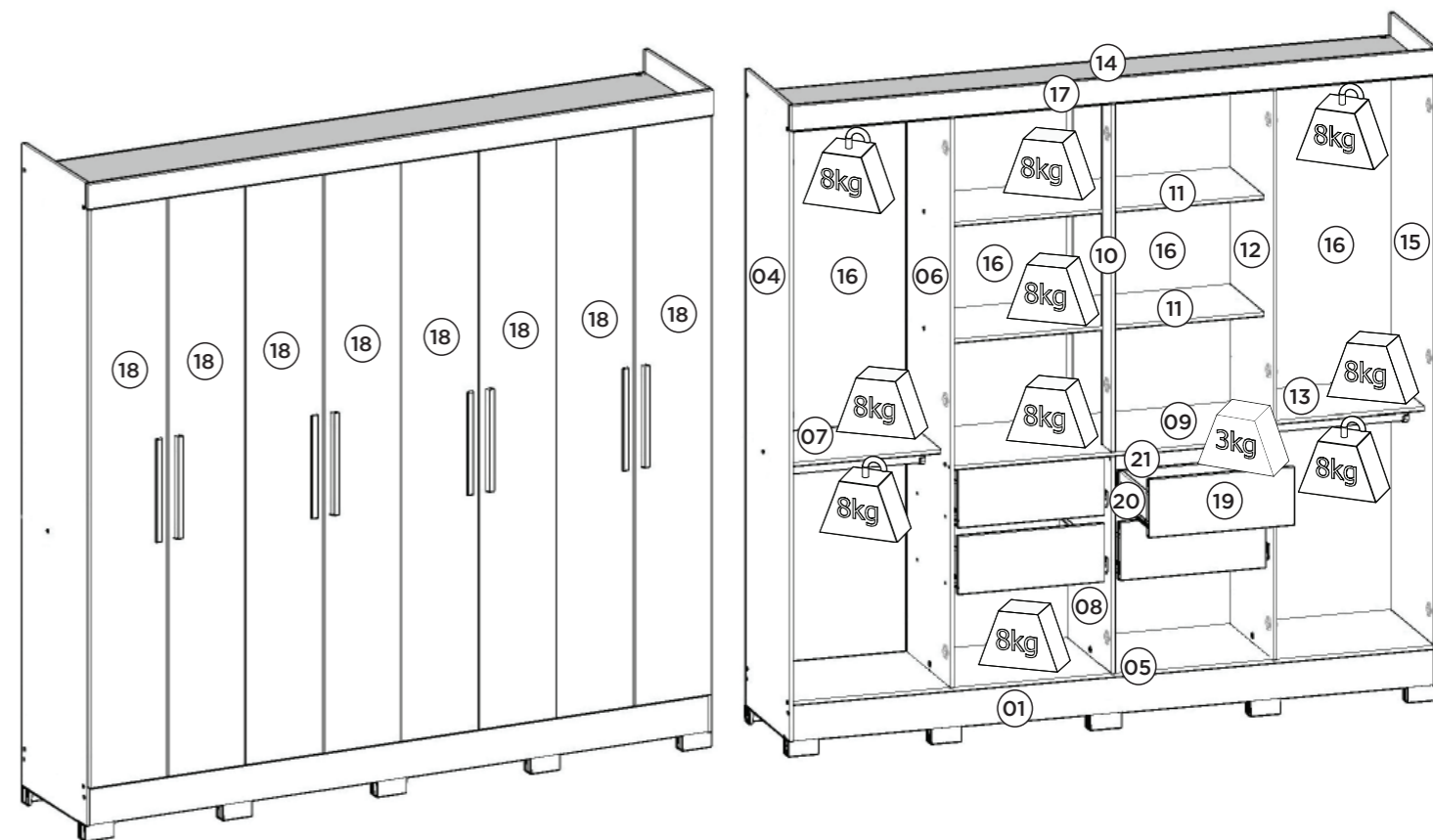

FERRAGENS | HERRAJES | HARDWARE

A 12x Parafuso 4,5x50mm CHT. Tornillo 4,5x50mm CHT. Screw 4,5x50mm CHT.	B 18x Parafuso 4,0x22mm MET. FLA. Tornillo 4,0x22mm MET. FLA. Screw 4,0x22mm MET. FLA.	C 17x Parafuso 3,5x40mm CHT. Tornillo 3,5x40mm CHT. Screw 3,5x40mm CHT.	D 16x Parafuso 3,5x25mm FLA. Tornillo 3,5x25mm FLA. Screw 3,5x25mm FLA.	E 142x Parafuso 3,5x12mm FLA. Tornillo 3,5x12mm FLA. Screw 3,5x12mm FLA.
F 32x Parafuso 3,5x12mm CHT. Tornillo 3,5x12mm CHT. Screw 3,5x12mm CHT.	G 32x Parafuso 3,0x16mm CHT. Tornillo 3,0x16mm CHT. Screw 3,0x16mm CHT.	H 03x Parafuso Minifix. Tornillo Minifix. Screw Minifix.	I 86x Cavilha 5x25mm Cinta 5x25mm Dowel 5x25mm	J 34x Fixador de fundos Fijador de fondos Bottom fixer
K 130x Prego 10x10mm Clavo 10x10mm Nail 10x10mm	L 08x Prego 12x12mm Anelado Clavo 12x12mm Anillado Ringed Nails 12x12mm	M 08x Suporte cabideiro Soporte de percha Coat hanger support	N 04x Cabideiro Madeira 519mm Cabezal Madera 519mm 519mm wooden hanger	O 24x Calço metal 5mm Calzado metálico 5mm 5mm metal shim
P 24x Dobradiça metal 26 mm Bisagra de metal 26 mm 26 mm metal hinge	Q 16x Distanciador de corrediça Distanciador de deslizamiento Sliding spacer	R 04x Corrediça metal 350mm Corredera metal 350mm Sliding metal 350mm	S 18x Porca sextavada Tuerca hexagonal Hexagon nuts	T 26x Cantoneira plástica Cantonera plástica Plastic angle brackets
U 10x Pé "U" 50x40x100mm Pie "U" 50x40x100mm 50x40x100mm "U" feet	V 12x Porca cilíndrica Tuerca cilíndrica Cylindrical nut	W 08x Perfil Puxador Revestido MDF 330mm Perfil Tirador Revestido MDF 330mm Profile MDF 330mm Coated Handle	X 01x Perfil "I" 1154mm Perfil "I" 1154mm Profile "I" 1154mm	Y 03x Tambor Minifix. Tambor Minifix. Minifix Drum.
Z 02x Sachê de cola Bolsa de pegamento Glue bag	AA 06x Adesivo tapa parafuso 17mm Adhesivo tapón de tornillo 17mm Bolt cover adhesive 17mm	AB 24x Adesivo tapa parafuso 10mm Adhesivo tapón de tornillo 10mm Bolt cover adhesive 10mm	AC 01x Etiqueta resinada Briz Etiqueta resinada Briz Briz resin label	

Requisitos para montagem
Requisitor para la montaje
Assembly Requirements

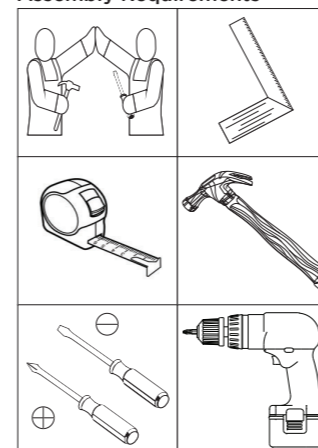

Imagens meramente ilustrativas
Imágenes meramente ilustrativas
Images for illustration only

Pesos máximos recomendados com carga distribuída
Peso máximo recomendado con la carga distribuida
Recommended maximum weights with evenly distributed.

AVISO

Para limpeza de seu móvel, use uma flanela seca ou umedecida, e não utilize produtos químicos que possam danificar seu produto.

SISTEMA DE MONTAGEM

O sistema de montagem dos produtos, funciona de acordo com a ordem crescente dos números indicados no desenho. Ex: 01, 02, 03, 04... até a conclusão da montagem.

ADVERTENCIA

Para limpieza de su móvil, use una flanela seca o húmeda, y no utilice productos químicos que puedan dañar su producto.

SISTEMA DE MONTAJE

El sistema de montaje de los productos funciona de acuerdo con el orden creciente de los números indicados en el dibujo. Ej.: 01, 02, 03, 04... hasta la conclusión del montaje.

NOTICE

To clean your furniture, use a dry or wet cloth, and do not use chemicals that may damage your product.

ASSEMBLY SYSTEM

The products' assembly system works according to the increasing order of the indicated numbers. For example: 01, 02, 03, 04 ... to the end of the assembly.

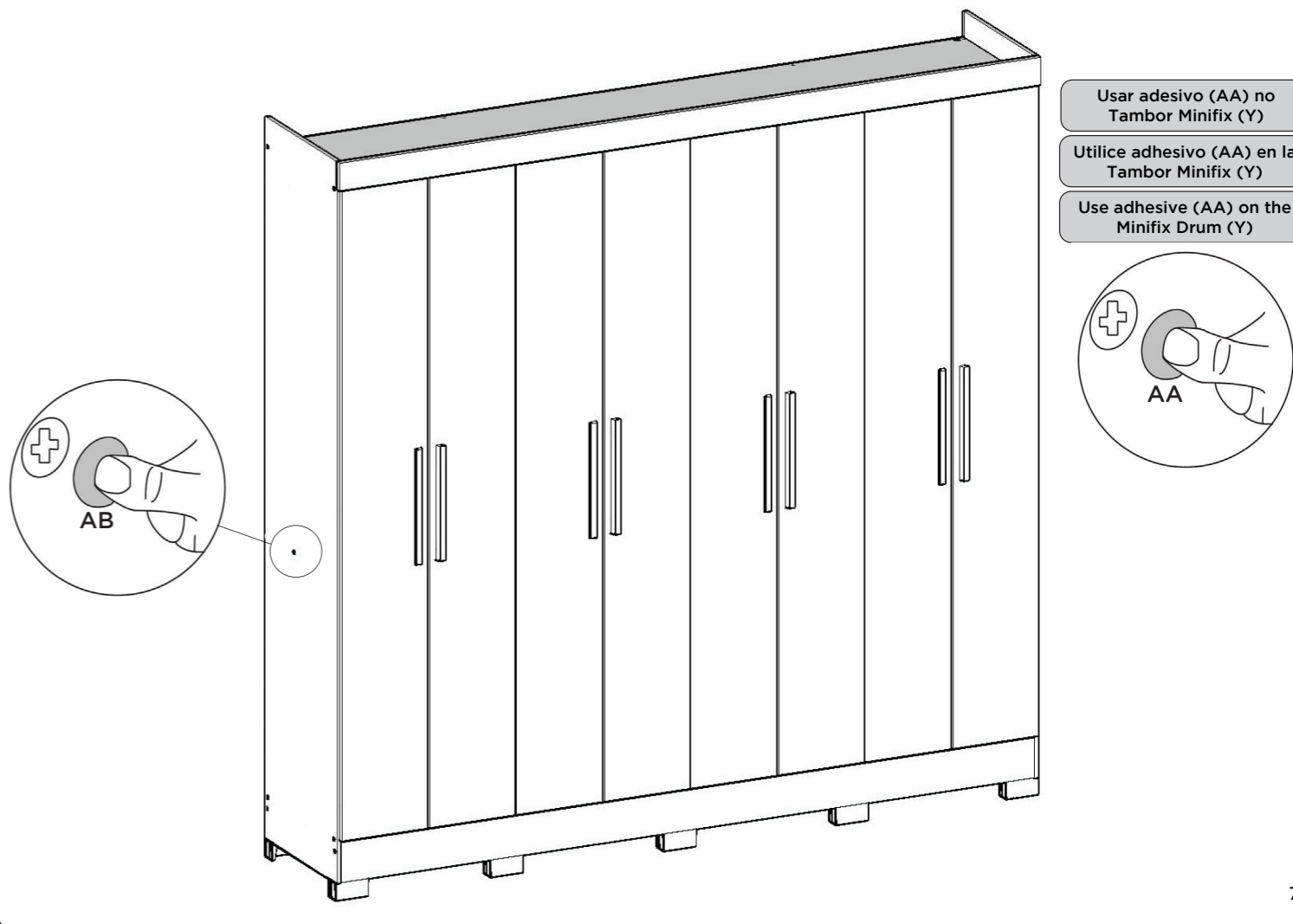
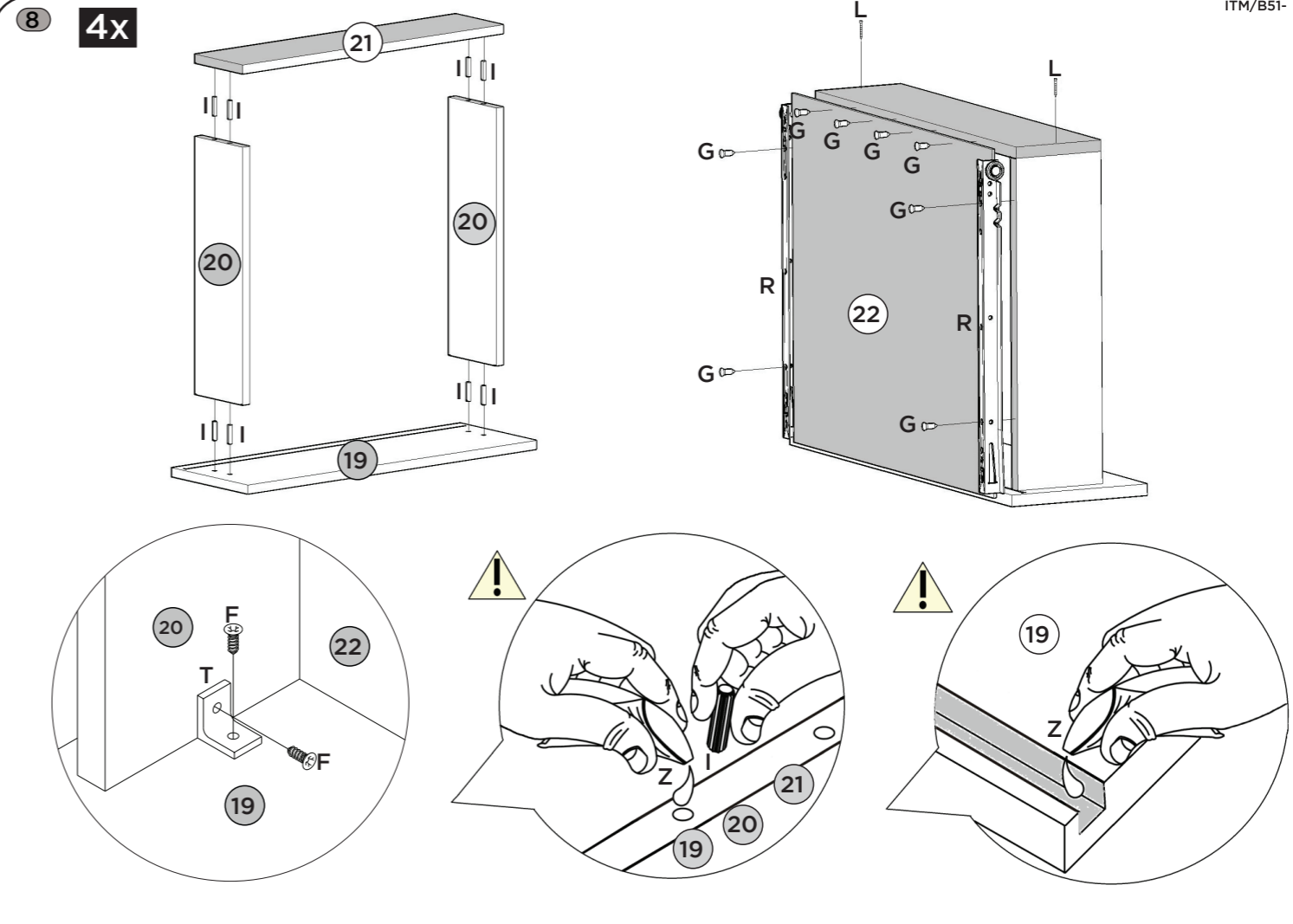
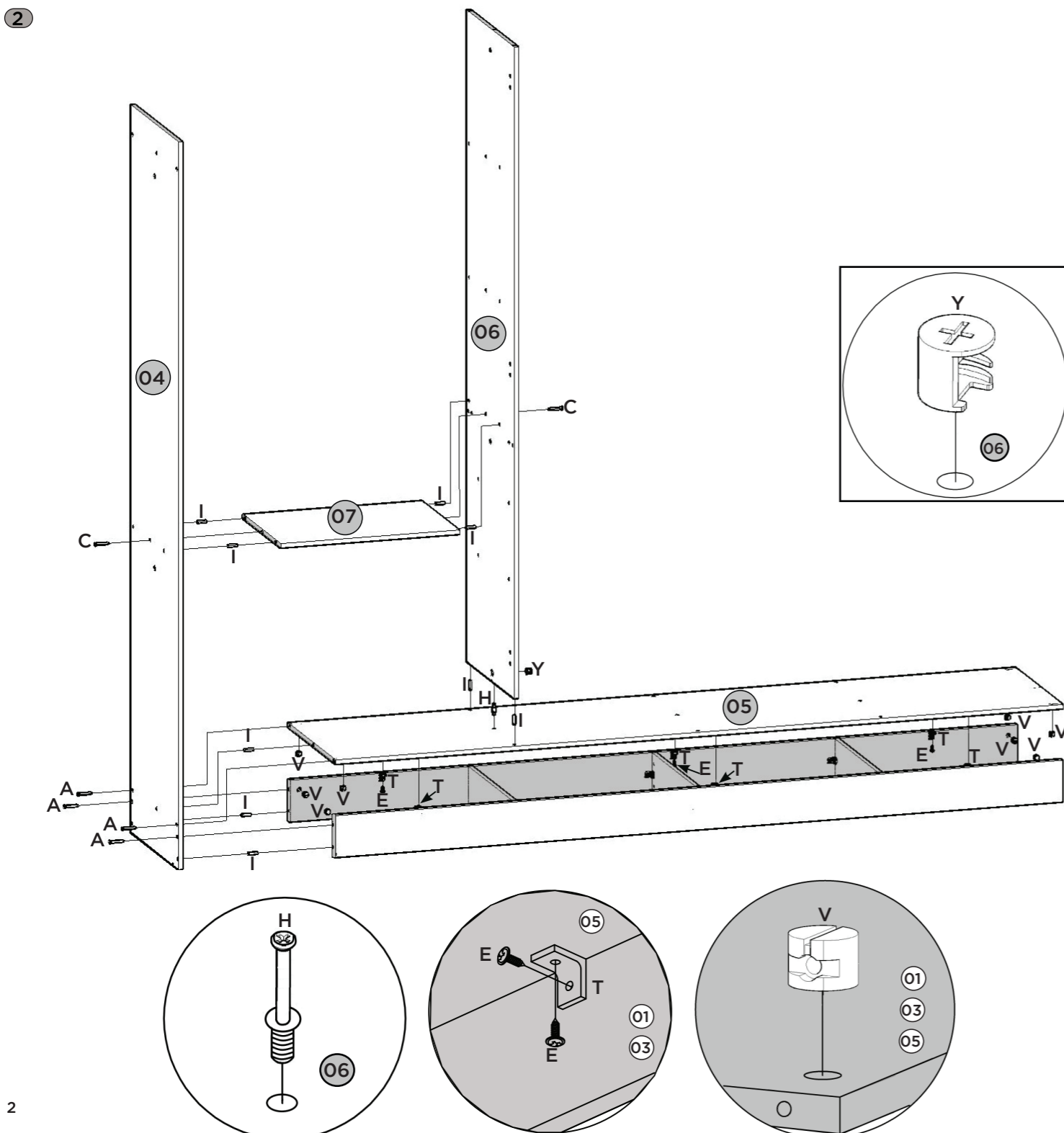
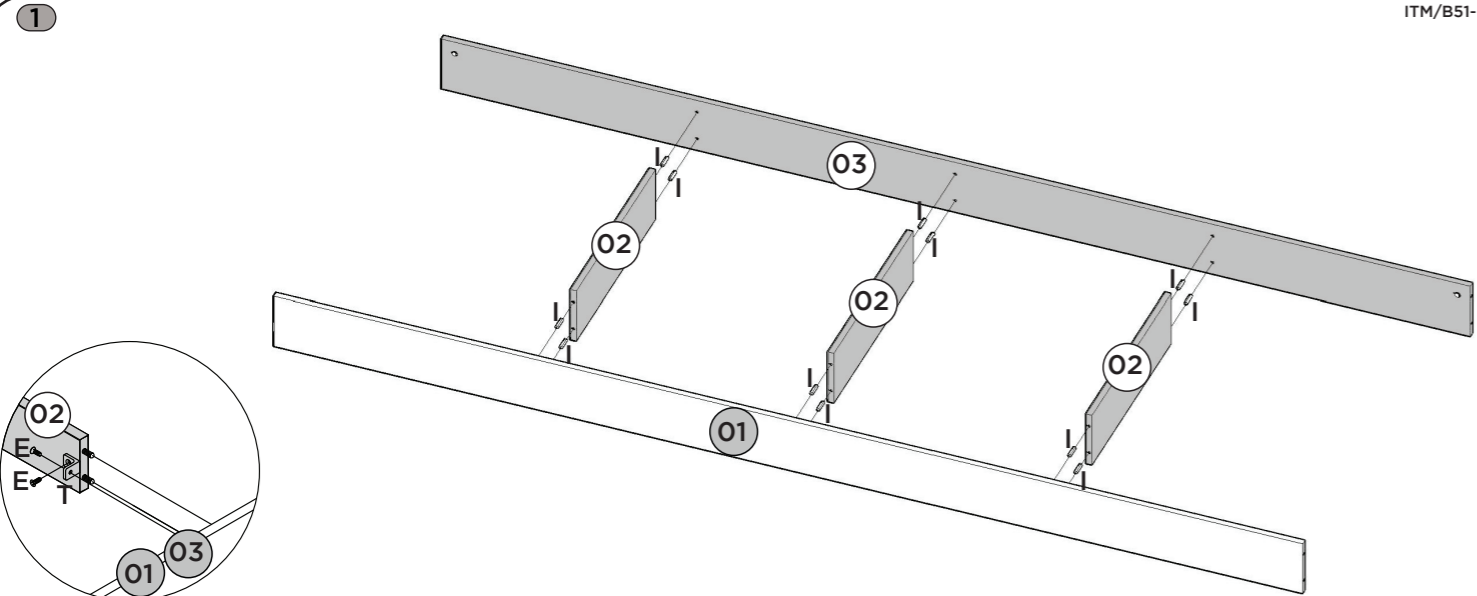

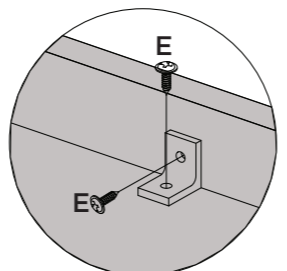
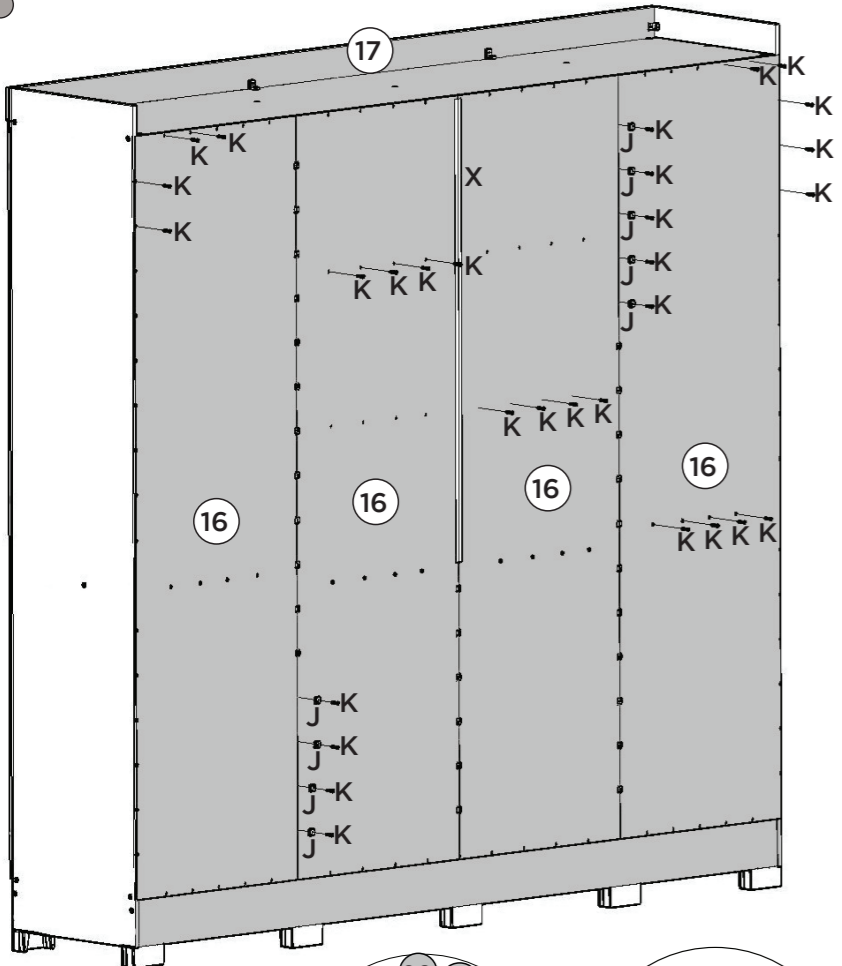

Fixar os pregos a uma distância de 120mm de um para outro.

Fijar las uñas a un distancia de 120 mm uno a otro.

Fix the nails at a distance of 120mm from one to the other

