

### Passo / Step / Paso 7:

Fixe a etiqueta Moveis Estrela

'N' na Sanefa Nº 11.

Fix 'N' in Nº 11.

Fije 'N' en Nº 11.

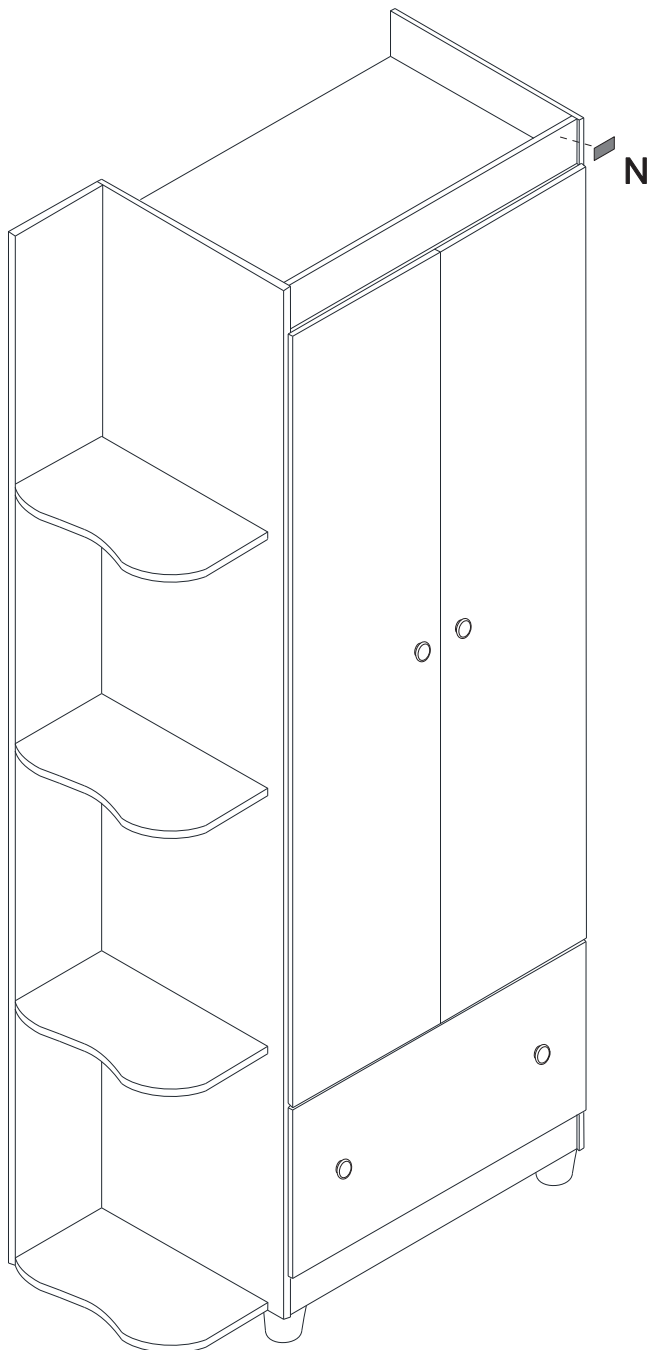
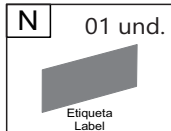

# MANUAL DE INSTRUÇÕES

MANUAL DE INSTRUCCIONES

INSTRUCTION MANUAL



GUARDA ROUPA GUTTI - 20A

GUTTI WARDROBE - 20A

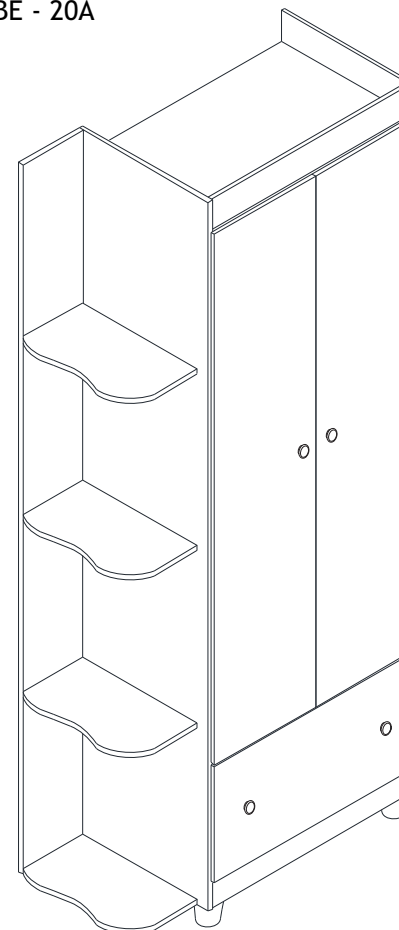

SUA CASA, SEU ESTILO

“IMAGENS MERAMENTE ILUSTRATIVAS,  
SUJEITAS À ALTERAÇÕES SEM PRÉVIO AVISO”



**Pessoas Necessárias para montagem**

**Necessary people for assembly**

1 Adulto  
1 Adult  
1 Adulto

**Gente necesaria para la asamblea**

**Ferramentas Necessárias (Não Inclusas)**

**Tools needed (not included)**

**Herramientas necesarias (no incluido)**



Martelo  
hammer  
martillo



Parafusadeira  
Screwdriver  
destornillador



Chave Fenda  
Slot Key  
Clave de runura



Chave Phillips  
Phillips Key  
Clave Phillips

## INFORMAÇÕES SOBRE SEGURANÇA

1. Esta embalagem contém peças pequenas, mantenha afastada de crianças até que o produto esteja montado.
2. As instruções são genéricas, as figuras podem variar.
3. Leia atentamente todas as instruções antes de iniciar a montagem.
4. Separe e guarde a etiqueta de identificação.
5. Confira se os volumes e quantidades de peças descritos no manual estão corretos.
6. Identifique as peças e separe os acessórios.
7. A montagem do produto deverá ser feita em uma superfície limpa e plana. Aconselhamos utilizar a própria embalagem para forrar o chão a fim de não danificar o produto.
8. Reservar área livre para montagem do produto.
9. Evitar batidas e o contato com objetos cortantes.
10. Não expor o móvel a calor excessivo (luz solar direta), ou umidade elevada.
11. Para limpeza use um pano macio seco ou ligeiramente umedecido com água. Não use agentes de limpeza ou abrasivos.

## SAFETY INFORMATION

1. This package contains small parts, keep away from children until the product is assembled.
2. The instructions are generic, the figures may vary.
3. Read all instructions carefully before starting assembly.
4. Separate and store the ID tag.
5. Check if the volumes and quantities of pieces described in the manual are correct.
6. Identify the pieces and separate accessories.
7. The assembly of the product shall be made on a clean and flat surface. We recommend using the package itself to cover the floor in order not to damage the product.
8. Reserve a specific area to assembly the product.
9. Avoid shocks and contact with sharp objects.
10. Do not expose the furniture to excessive heat (direct sunlight), or high humidity.
11. For cleaning use a dry soft cloth or slightly moistened with water. Do not use cleaning agents or abrasives

## INFORMACIÓN DE SEGURIDAD

1. Este paquete contiene piezas pequeñas, mantenga alejado de los niños hasta que el producto esté montado.
2. Las instrucciones son genéricas, los dibujos pueden variar.
3. Lea todas las instrucciones cuidadosamente antes de empezar el montaje.
4. Separar y almacenar la etiqueta de identificación.
5. Verifique si los volúmenes y cantidades de las piezas descritas en el manual estan correctas.
6. Identificar las piezas y separar los accesorios.
7. El montaje del producto se efectuará sobre una superficie limpia y plana. Se recomienda usar el propio envase para cubrir el suelo con el fin de no dañar el producto.
8. Reserve una área específica para el montaje del producto.
9. Evitar los golpes y el contacto con objetos afilados.
10. No exponga el mueble a un calor excesivo (luz solar directa), o alta humedad.
11. Para la limpieza utilice un paño suave y seco o ligeramente humedecido con agua. No utilice productos de limpieza o abrasivos

## Passo / Step / Paso 6:

Encaixe as portas, gaveta e cabideiro no Guarda roupa.

Fit the doors, drawer and clothes rack into the wardrobe ..





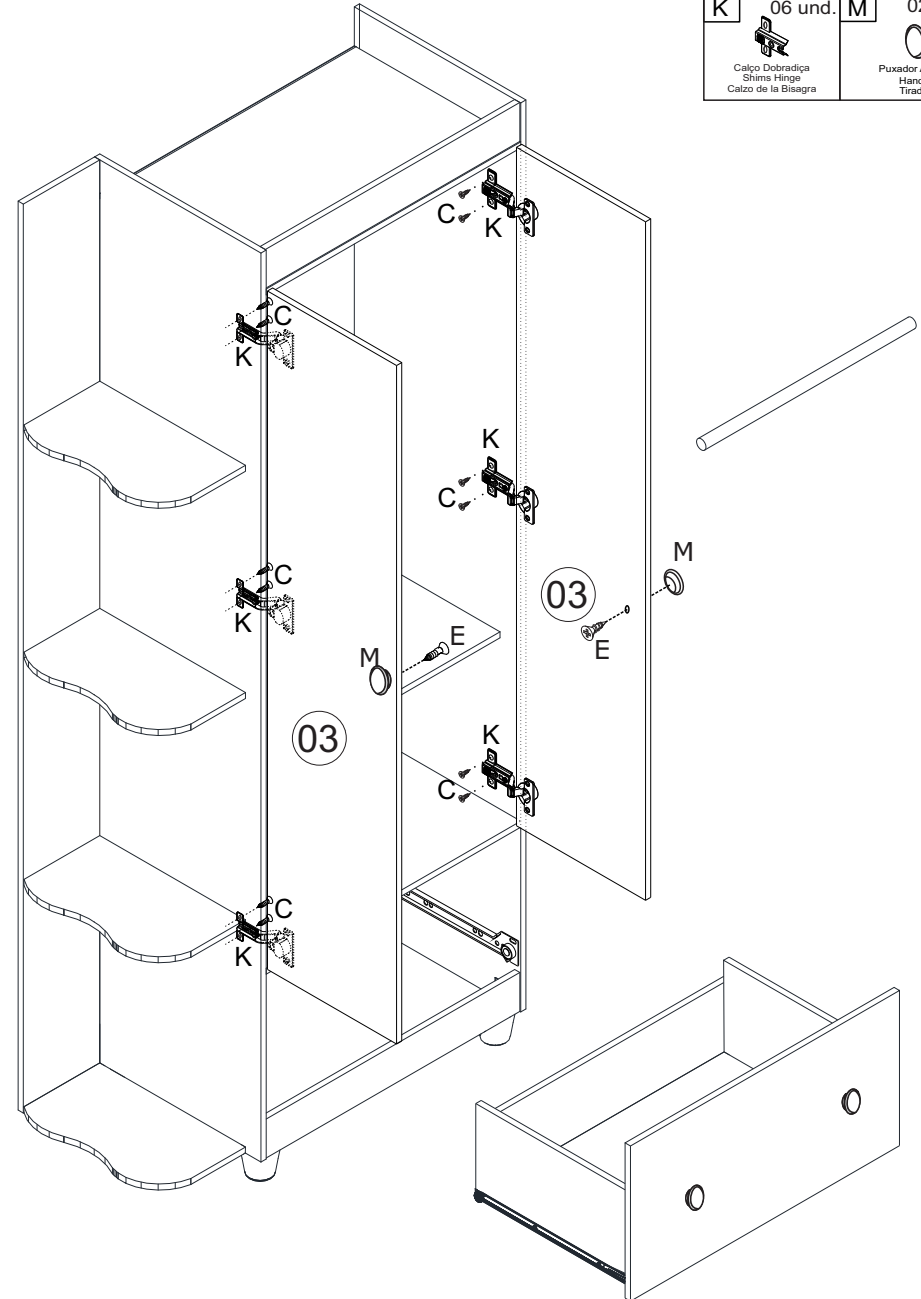



Coloque las puertas, el cajón y el estante de ropa en el armario..

<b>C</b>	12 und.	<b>E</b>	02 und.
	Parafuso 3,5x12 CC Phillips Screw 3,5x12 CC Phillips Tornillo 3,5x12 CC Phillips		Parafuso 4,0x25 CC Phillips Screw 4,0x25 CC Phillips Tornillo 4,0x25 CC Phillips
<b>K</b>	06 und.	<b>M</b>	02 und.
	Calço Dobradiça Shims Hinge Calzo de la Bisagra		Puxador Apiuna Handle Tirador



### Passo / Step / Paso 5:

Fixe as peças a seguir conforme esquema.  
Secure the following parts as shown.  
Asegure las siguientes partes como se muestra.

- A** 08 und.  
  
Parafuso 3,5 x 10 CC Phillips  
Screw 3,5 x 10 CC Phillips  
Tornillo 3,5 x 10 CC Phillips
- B** 04 und.  
  
Parafuso 4,0x40 CC Phillips  
Screw 4,0x40 CC Phillips  
Tornillo 4,0x40 CC Phillips
- D** 10 und.  
  
Parafuso 3,0x20 CC Phillips  
Screw 3,0x20 CC Phillips  
Tornillo 3,0x20 CC Phillips
- E** 02 und.  
  
Parafuso 4,0x25 CC Phillips  
Screw 4,0x25 CC Phillips  
Tornillo 4,0x25 CC Phillips
- G** 04 und.  
  
Cavilha 6 x 30  
Dowel 6 x 30  
Clavija 6 x 30
- L** 04 und.  
  
Cantoneira Triang. 18x18 mm  
Corner Brace 18 x 18 mm  
Abrazadera Metalica 18 x 18 mm
- M** 02 und.  
  
Puxador Apiuna  
Handle  
Tirador
- R** 02 und.  
  
Corrediça 350 mm  
Sliding rails 350 mm  
Rieles 350 mm

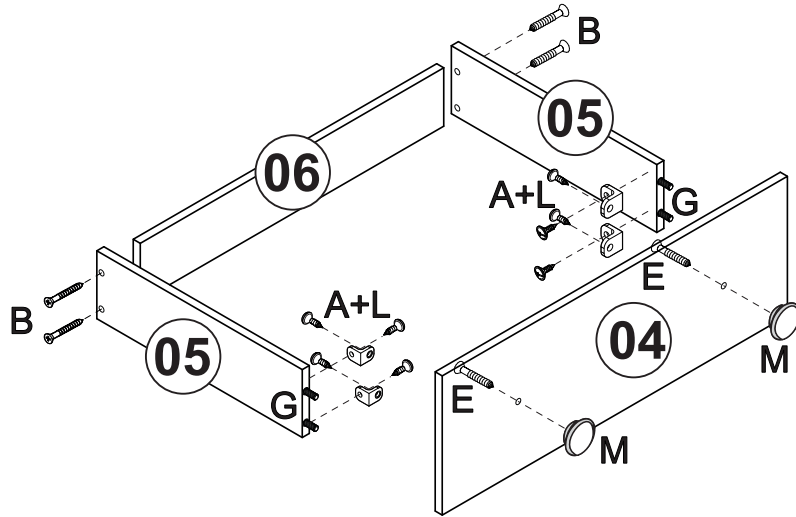

Depois vire a gaveta e fixe o fundo.  
Luego voltee el cajón y asegure el fondo.  
Then turn the drawer over and secure the bottom.

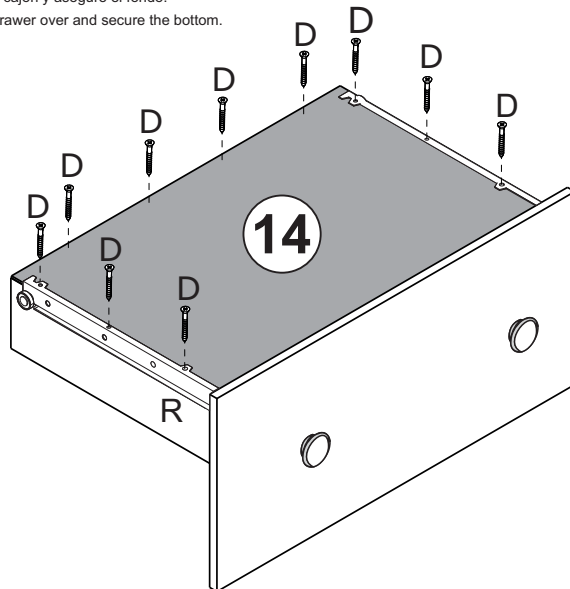

### PESO SUPORTADO / DIMENSÕES PRODUTO MONTADO SUPPORTED WEIGHT / DIMENSIONS ASSEMBLED PRODUCT PESO SOPORTADO / DIMENSIONES PRODUCTO ARMADO

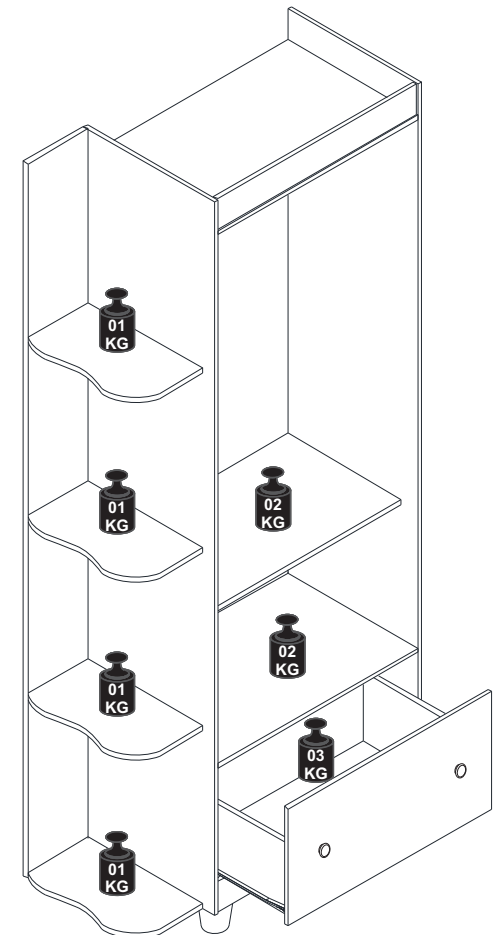
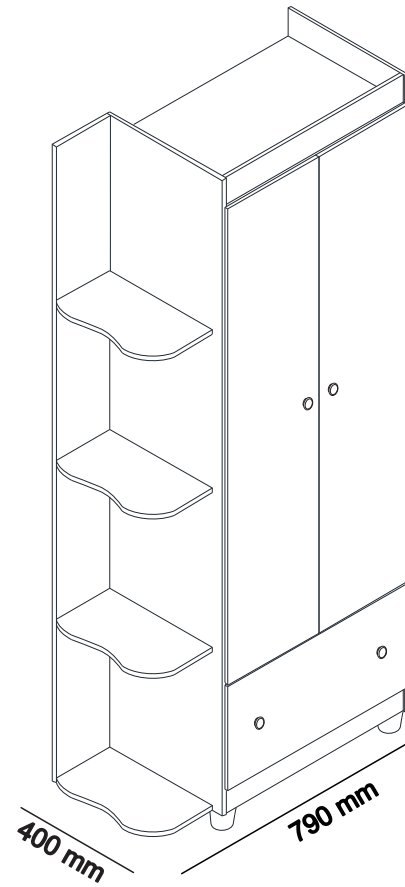

IDENTIFICAÇÃO DAS PEÇAS / IDENTIFICATION OF PARTS / IDENTIFICACIÓN DE LAS PIEZAS

CÓD.	IDENTIFICAÇÃO DAS PEÇAS	IDENTIFICATION OF PARTS	IDENTIFICACIÓN DE LAS PIEZAS	QTD
01	Lateral Direita	Right Side	Lateral Derecha	1
02	Lateral Esquerda	Left Side	Lateral Izquierda	1
03	Porta	Door	Puerta	2
04	Frente de Gaveta	Drawer Front	Frente del Cajón	1
05	Lateral de Gaveta	Drawer Side	Lado del Cajón	2
06	Contra Fundo	Drawer Back	Trasera del Cajón	1
07	Prateleiras	Shelf	-----	1
08	Tampo do Gaveteiro	Drawers top	Superior Cajón	1
09	Chapeu	Top Board	Tampo Superior	1
10	Rodapé Frontal / Traseiro	Front Baseboard / Back	Rodapie Frontal / Trasero	2
11	Rodateo	Top Board	Rodatecho	1
12	Fundo da prateleira	Shelf background	Estante de fondo	1
13	Prateleira usinada	Machined shelf	Estante mecanizado	4
14	Fundo Gaveta	Drawer Bottom	Fondo del Cajón	1
15	Fundo GR Menor	Wardrobe Background	Fondo de armario	1
16	Fundo GR Maior	Wardrobe Background Bigger	Fondo de armario Grande	1

IDENTIFICAÇÃO DAS PEÇAS / IDENTIFICATION OF PARTS / IDENTIFICACIÓN DE LAS PIEZAS

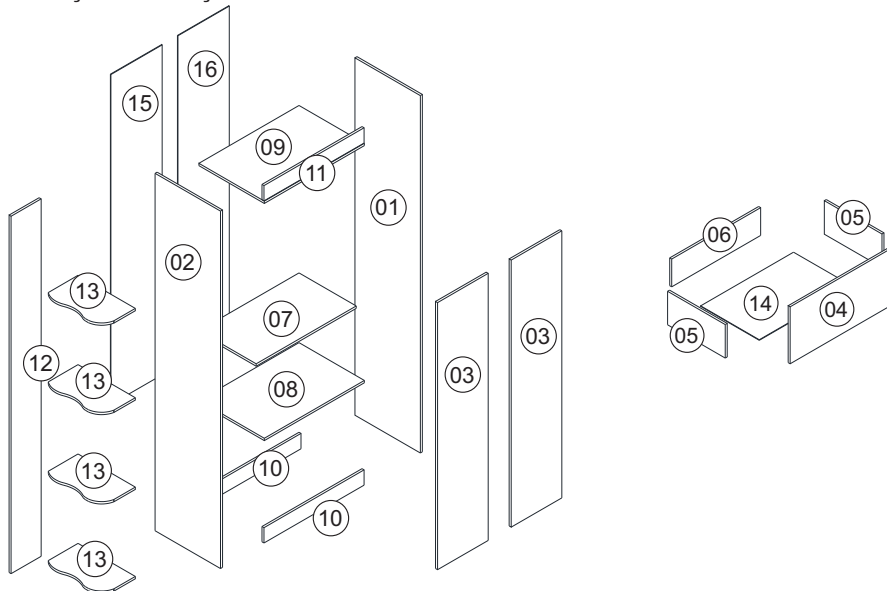

**ASSISTÊNCIA TÉCNICA**

Ao solicitar assistência técnica, informe o número da peça, nome, cor do produto e a data de fabricação do lote que se encontra carimbado na peça Nº 14

**TECHNICAL ASSISTANCE**



When request the technical assistance, inform the number of the piece name and color of the product and also the batch manufacturing date, that is stamped on the piece nº14.

**ASISTENCIA TÉCNICA**

Al solicitar la asistencia técnica, informe el número de la pieza, el nombre y el color del producto y también la fecha de fabricación del lote, que se estampa en la pieza nº14

**Passo / Step / Paso 4:**

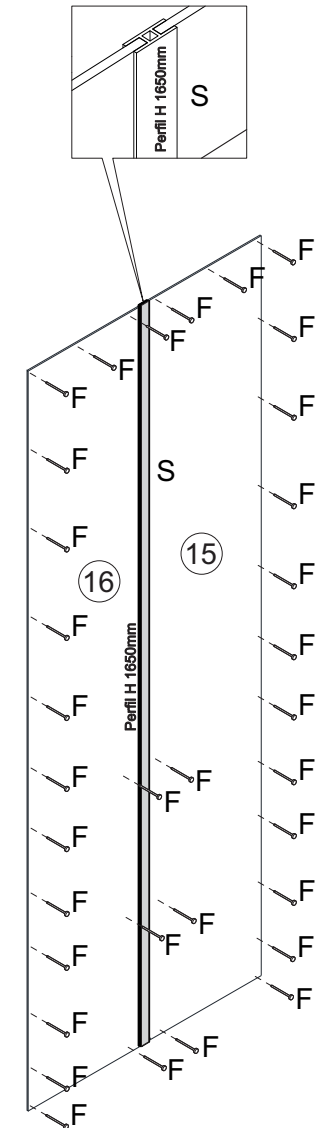
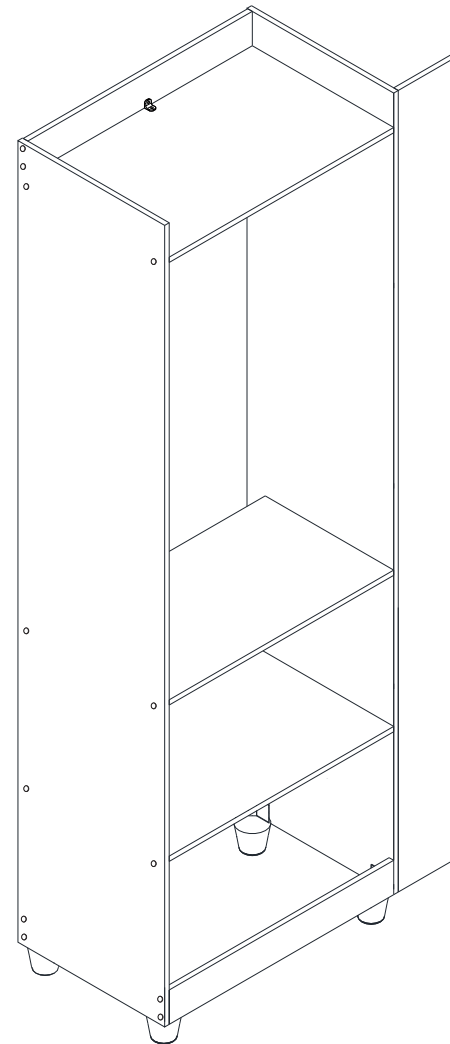

Fixe as peças a seguir conforme esquema.  
Secure the following parts as shown.  
Asegure las siguientes partes como se muestra.

<b>F</b>	34 und.	<b>S</b>	01 und.
 Prego 8x8 Nail 8x8 Clavo 8x8		 Perfil H 1650mm	



### Passo / Step / Paso 3:

Fixe as peças a seguir conforme esquema.  
Secure the following parts as shown.  
Asegure las siguientes partes como se muestra.

<b>B</b>	20 und.	<b>C</b>	16 und.	<b>I</b>	04 und.
					
Parafuso 4,0x40 CC Philips Screw 4,0x40 CC Philips Tornillo 4,0x40 CC Philips		Parafuso 3,5x12 CC Philips Screw 3,5x12 CC Philips Tornillo 3,5x12 CC Philips		Pé Foot Pie	

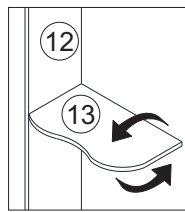
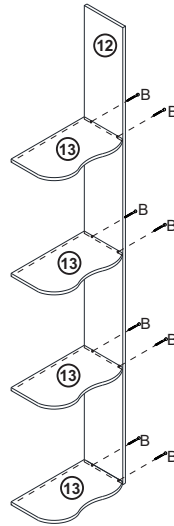
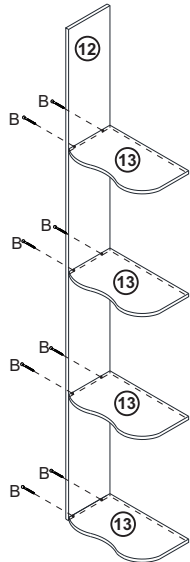

Escolha em que lado ficará a prateleira em seguida gire a prateleira para fixar por meio da pre furação interna do móvel, igual ao esquema a seguir.

Choose which side the shelf will be on then rotate the shelf to secure through the internal drilling of the furniture, same as the following scheme.

Elija de qué lado estará el estante luego gire el estante para asegurar a través de la perforación interna de los muebles, igual que el siguiente esquema.

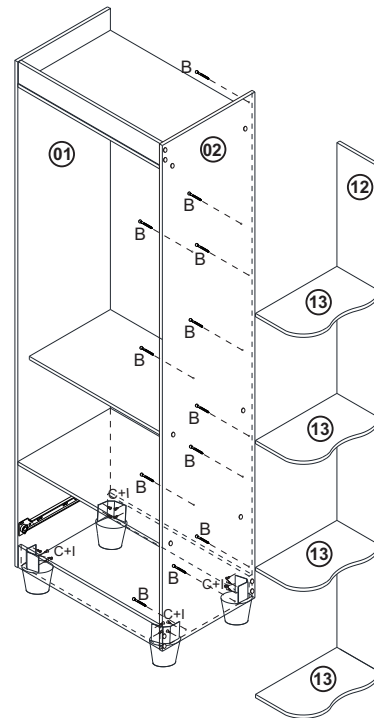
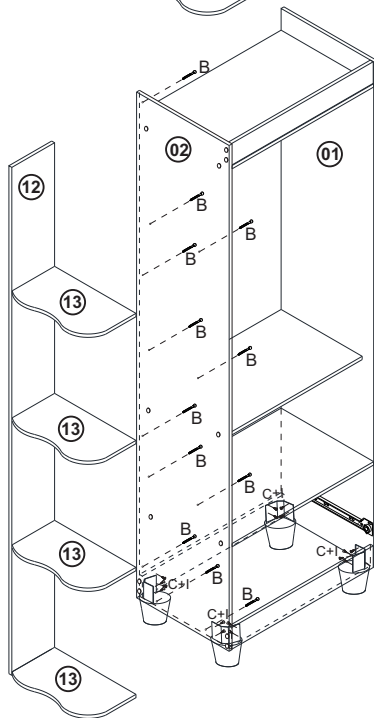

1 Adulto  
1 Adult  
1 Adulto

Pessoas Necessárias para montagem

Necessary people for assembly

Gente necesaria para la asamblea

Ferramentas Necessárias (Não Inclusas)

Tools needed (not included)

Herramientas necesarias (no incluido)



Martelo  
hammer  
martillo



Parafusadeira  
Screwdriver  
destornillador











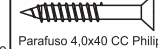







Chave Fenda  
Slot Key  
Clave de runura

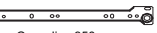
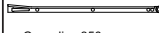

Chave Phillips  
Phillips Key  
Clave Phillips

### FERRAGENS

<b>A</b>	10 und.	<b>B</b>	48 und.	<b>C</b>	52 und.	<b>D</b>	10 und.	<b>E</b>	04 und.	<b>F</b>	34 und.
											
Parafuso 3,5 x 10 Flangeado Screw 3,5 x 10 Flangeado Tornillo 3,5 x 10 Flangeado		Parafuso 4,0x40 CC Philips Screw 4,0x40 CC Philips Tornillo 4,0x40 CC Philips		Parafuso 3,5x12 CC Philips Screw 3,5x12 CC Philips Tornillo 3,5x12 CC Philips		Parafuso 3,0x20 CC Philips Screw 3,0x20 CC Philips Tornillo 3,0x20 CC Philips		Parafuso 4,0x25 CC Philips Screw 4,0x25 CC Philips Tornillo 4,0x25 CC Philips		Prego 8x8 Nail 8x8 Clavo 8x8	
<b>G</b>	16 und.	<b>H</b>	24 und.	<b>I</b>	04 und.	<b>J</b>	06 und.	<b>K</b>	06 und.	<b>L</b>	05 und.
											
Cavilha 6 x 30 Dowel 6 x 30 Clavija 6 x 30		Tampa Adesiva 12mm Adhesive label 12mm Tapa adhesiva 12mm		Pé Foot Pie		Dobradiça Hinge Bisagra		Calço Dobradiça Shims Hinge Calzo de la Bisagra		Cantoneira Triang. 18x18 mm Corner Braca 18 x 18 mm Abrazadera Metalica 18 x 18 mm	
<b>M</b>	04 und.	<b>N</b>	01 und.	<b>O</b>	01 und.	<b>P</b>	02 und.	<b>Q</b>	02 und.	<b>R</b>	02 und.
											
Puxador Apiuna Handle Tirador		Etiqueta Label		Bastão Cabideiro 580mm Hanging Rail 580mm Perchero 580mm		Suporte Bastão Cabideiro Plastic Bar Support Soporte Barra de Plastico		Corrediza 350 mm Sliding rails 350 mm Rieles 350 mm		Corrediza 350 mm Sliding rails 350 mm Rieles 350 mm	
<b>S</b>	01 und.										
		Perfil H 1650mm									

FERRAGENS ESCALA REAL / REAL SCALE IRONMONGERY / HERRAJES EN TAMAÑO COMPLETO

**A** 10 und.



**B** 48 und.

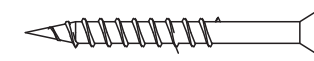

**C** 52 und.

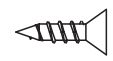

**D** 10 und.

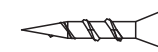

**E** 04 und.



**F** 34 und.

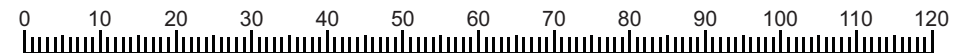
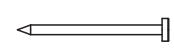





Medidas em mm

**MONTAGEM DO PRODUTO / PRODUCT ASSEMBLY / MONTAJE DEL PRODUCTO**

**Passo / Step / Paso 1:**

Prepare as peças abaixo seguindo o esquema a seguir.  
 Prepare the parts below by following the diagram below.  
 Prepare las partes a continuación siguiendo el diagrama a continuación.

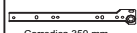
<b>C</b> 24 und.	<b>G</b> 12 und.	<b>J</b> 06 und.
 Parafuso 3,5x12 CC Phillips Tornillo 3,5x12 CC Phillips	 Cavilha 6 x 30 Dowel 6 x 30 Clavija 6 x 30	 Dobradilha Hinge Bisagra
<b>P</b> 02 und.	<b>Q</b> 02 und.	
 Suporte Bastião Cabideiro Plastic Bar Support Soporte Barra de Plastico	 Corrediza 350 mm Sliding rails 350 mm Rieles 350 mm	

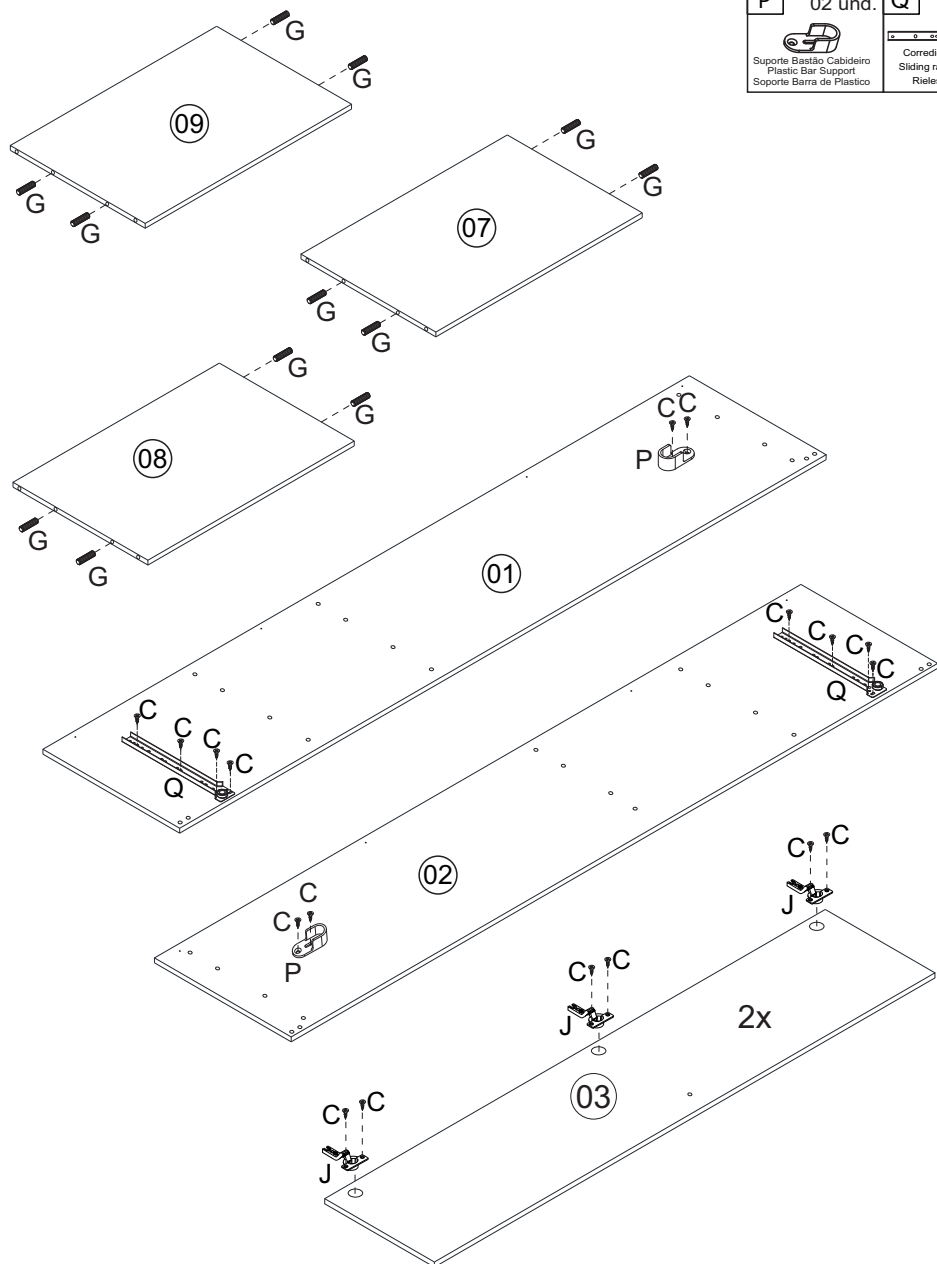





**Passo / Step / Paso 2:**

Fixe as peças a seguir conforme esquema.  
 Secure the following parts as shown.  
 Asegure las siguientes partes como se muestra.

Dependendo da cor escolhida, o montador deve inverter o lado da peça nº 11 ou colocar a peça nº 10 no lugar da peça nº 11.

Dependiendo del color elegido, el ensamblador debe reverse de la parte # 11 o colocar la parte # 10 en lugar de la parte # 11.

Depending on the color chosen, the assembler should reverse side of part # 11 or place part # 10 in place of part # 11.

<b>A</b> 02 und.	<b>B</b> 24 und.	<b>H</b> 24 und.	<b>L</b> 01 und.
 Parafuso 3,5 x 10 CC Phillips Screw 3,5 x 10 CC Phillips Tornillo 3,5 x 10 CC Phillips	 Parafuso 4,0x40 CC Phillips Screw 4,0x40 CC Phillips Tornillo 4,0x40 CC Phillips	 Tampa Adesiva 12mm Adhesive label 12mm Tapa adhesiva 12mm	 Cantoneira Triang. 18x18 mm Corner brace 18 x 18 mm Abrazadera Metalica 18 x 18 mm

