





Passo / Step / Paso 9:

9.1 - Fixe os acessórios e a porta conforme esquema a seguir.

9.1 - Fix the accessories and the door according to the diagram below.

9.1 - Fije los accesorios y la puerta de acuerdo con el siguiente diagrama.

D	24 und.	G	24 und.
	Parafuso 4.0 x 16 CC Screw 4.0 x 16 CC Tornillo 4.0 x 16 CC		Parafuso 3.5 x 12 CC Screw 3.5 x 12 CC Tornillo 3.5 x 12 CC
L	12 und.	A1	01 und.
	Dobradiça Hinge Bisagra		Etiqueta Label
		A2	01 und.
			Bastão Cabideiro 905 mm Hanging Rail 905 mm Perchero 905 mm

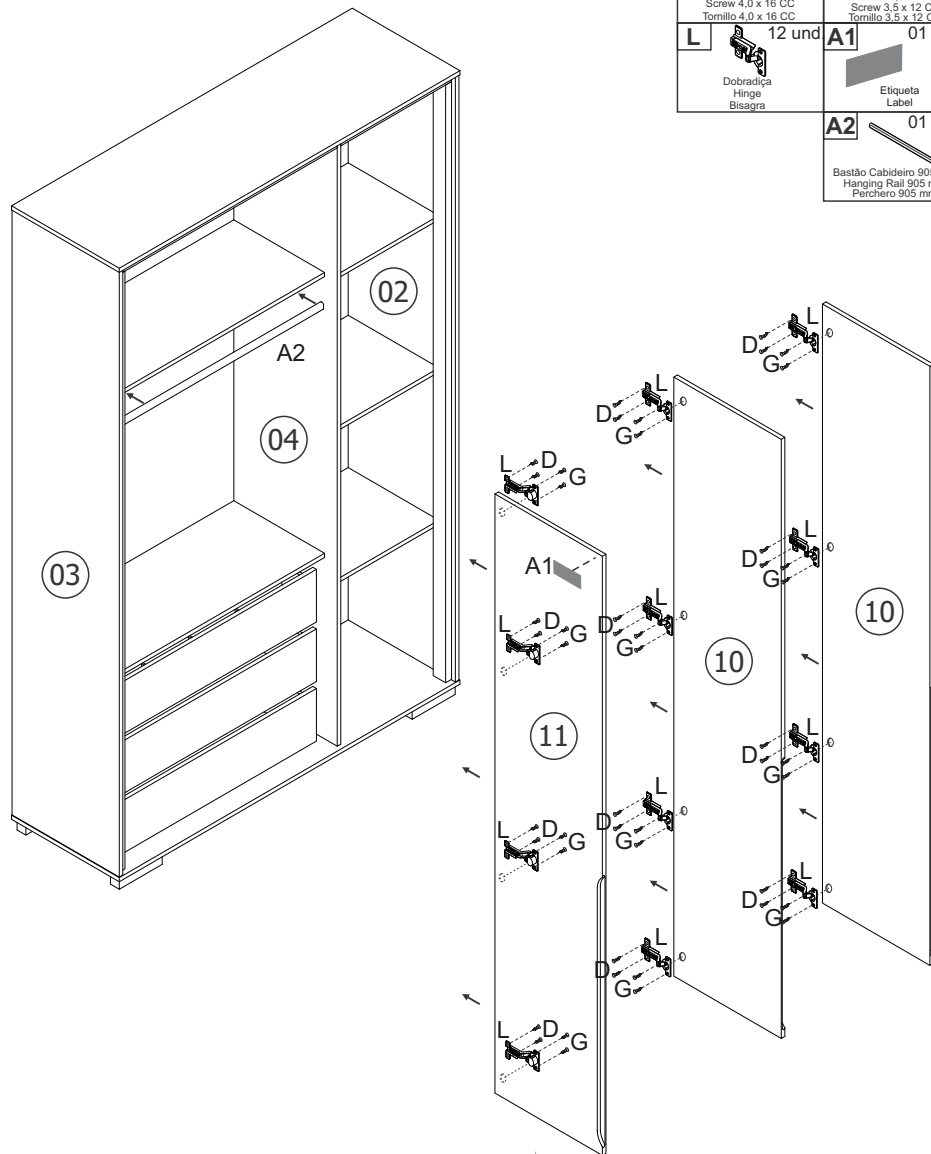

M.E. GONÇALVES

INDÚSTRIA DE MÓVEIS LTDA.

Avenida Maracanã, 4244 - Parque Industrial

Arapongas - PR - Brasil

Fone: +55 (43) 3274-8800

www.moveisestrela.com.br

MANUAL DE INSTRUÇÕES

MANUAL DE INSTRUCCIONES

INSTRUCTION MANUAL

22818 - GUARDA ROUPA SLOAN - 20A

22818 - CLOTHING GUARD SLOAN - 20A

22818 - GUANTE DE ROPA SLOAN - 20A

DISPONÍVEIS NAS CORES

AVAILABLE IN COLORS

DISPONIBLE EN COLORES

1881 - BRANCO

1881 - WHITE

1881 - BLANCO

8729 - OFF WHITE

8729 - OFF WHITE

8729 - OFF WHITE

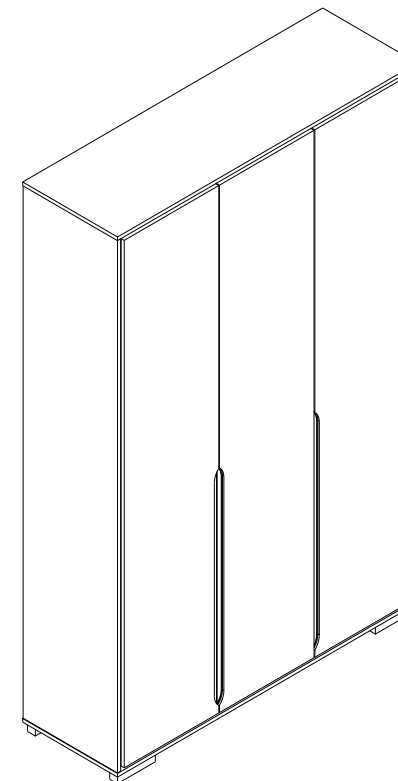

"Imagens meramente ilustrativas, sujeitas a alterações sem aviso prévio"

"Image merely illustrative, subject to change without prior notice"

"Imágenes ilustrativas, pueden ser cambiadas sin aviso previo"



1 Adulto
1 Adult
1 Adulto

Pessoas Necessárias para montagem

Necessary people for assembly

Gente necesaria para la asamblea

Ferramentas Necessárias (Não Incluídas)

Tools needed (not included)

Herramientas necesarias (no incluido)



Martelo
hammer
martillo



Parafusadeira
Screwdriver
destornillador



Chave Fenda
Slot Key
Clave de runura



Chave Phillips
Phillips Key
Clave Phillips

INFORMAÇÕES SOBRE SEGURANÇA

1. Esta embalagem contém peças pequenas, mantenha afastada de crianças até que o produto esteja montado.
2. As instruções são genéricas, as figuras podem variar.
3. Leia atentamente todas as instruções antes de iniciar a montagem.
4. Separe e guarde a etiqueta de identificação.
5. Confira se os volumes e quantidades de peças descritos no manual estão corretos.
6. Identifique as peças e separe os acessórios.
7. A montagem do produto deverá ser feita em uma superfície limpa e plana. Aconselhamos utilizar a própria embalagem para forrar o chão a fim de não danificar o produto.
8. Reservar área livre para montagem do produto.
9. Evitar batidas e o contato com objetos cortantes.
10. Não expor o móvel a calor excessivo (luz solar direta), ou umidade elevada.
11. Para limpeza use um pano macio seco ou ligeiramente umedecido com água. Não use agentes de limpeza ou abrasivos.

SAFETY INFORMATION

1. This package contains small parts, keep away from children until the product is assembled.
2. The instructions are generic, the figures may vary.
3. Read all instructions carefully before starting assembly.
4. Separate and store the ID tag.
5. Check if the volumes and quantities of pieces described in the manual are correct.
6. Identify the pieces and separate accessories.
7. The assembly of the product shall be made on a clean and flat surface. We recommend using the package itself to cover the floor in order not to damage the product.
8. Reserve a specific area to assembly the product.
9. Avoid shocks and contact with sharp objects.
10. Do not expose the furniture to excessive heat (direct sunlight), or high humidity.
11. For cleaning use a dry soft cloth or slightly moistened with water. Do not use cleaning agents or abrasives

INFORMACIÓN DE SEGURIDAD

1. Este paquete contiene piezas pequeñas, mantenga alejado de los niños hasta que el producto esté montado.
2. Las instrucciones son genéricas, los dibujos pueden variar.
3. Lea todas las instrucciones cuidadosamente antes de empezar el montaje.
4. Separar y almacenar la etiqueta de identificación.
5. Verifique si los volúmenes y cantidades de las piezas descritas en el manual están correctas.
6. Identificar las piezas y separar los accesorios.
7. El montaje del producto se efectuará sobre una superficie limpia y plana. Se recomienda usar el propio envase para cubrir el suelo con el fin de no dañar el producto.
8. Reserve una área específica para el montaje del producto.
9. Evitar los golpes y el contacto con objetos afilados.
10. No exponga el mueble a un calor excesivo (luz solar directa), o alta humedad.
11. Para la limpieza utilice un paño suave y seco o ligeramente humedecido con agua. No utilice productos de limpieza o abrasivos

Passo / Step / Paso 8:

8.1 - Fixe os fundos colocando os perfis conforme esquema a seguir.

8.1 - Fix the funds by placing the profiles according to the scheme below.

8.1 - Arregle los fondos colocando los perfiles de acuerdo con el esquema a continuación.

FIXAR NA PAREDE
COM 'A' + 'M'

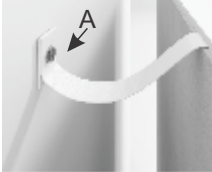

A	02 und.
	Parafuso 5,0 x 50 CC Screw 5,0 x 50 CC Tornillo 5,0 x 50 CC
G	04 und.
	Parafuso 3,5 x 12 CC Screw 3,5 x 12 CC Tornillo 3,5 x 12 CC
H	82 und.
	Prego 8 x 8 Nail 8 x 8 Clavo 8 x 8
O	10 und.
	Chapa União Fundo Insulation Pins Chapa prendedora
M	02 und.
	Bucha Ivasa 8mm 8mm Ivasa Bushing Casquillo Ivasa 8 mm
V	01 und.
	Perfil H 49,8 cm
X	01 und.
	Perfil H 99,4 cm
W	01 und.
	Perfil H 65,2 cm
A3	02 und.
	Alça de segurança Security Tape Cinta de seguridad

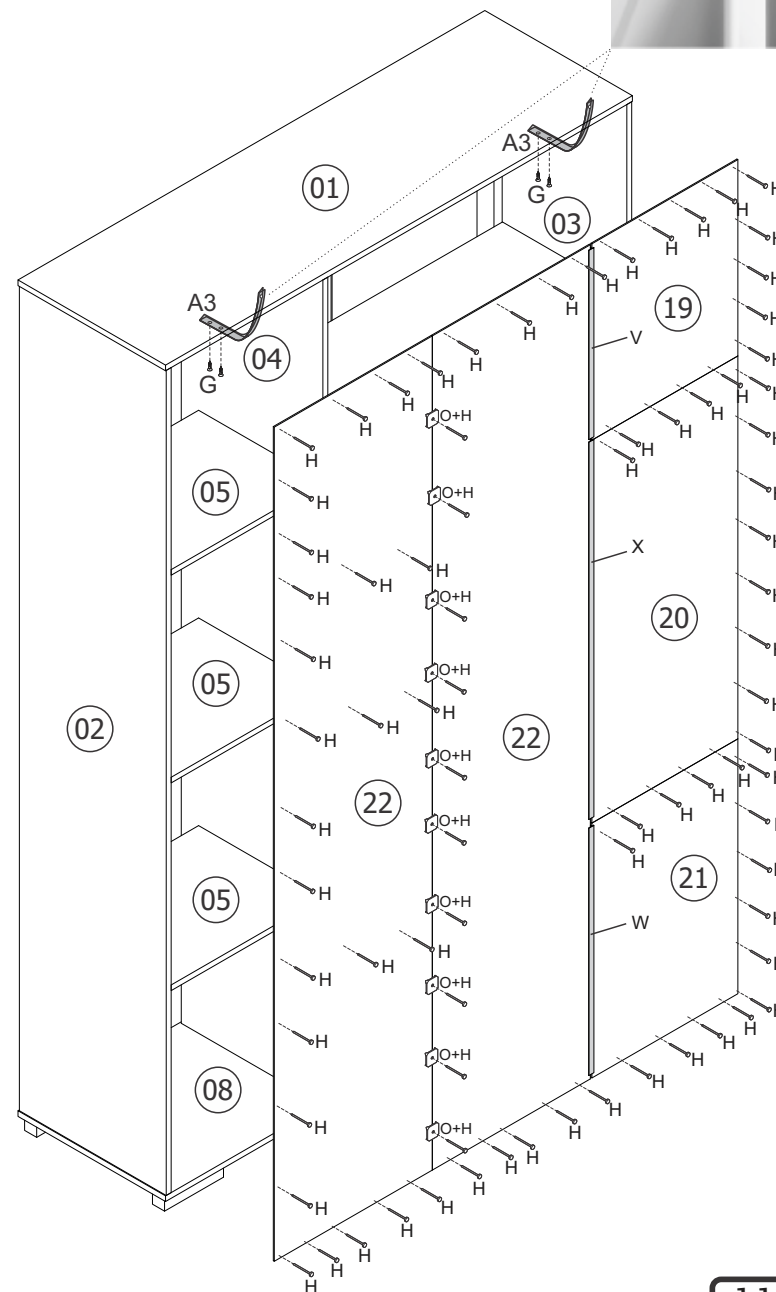

Passo / Step / Paso 7:

7.1 - Fixe os engrossos depois coloque as gavetas conforme esquema a seguir.
7.1 - Fix the thickeners then place the drawers according to the diagram below.
7.1 - Fije los espesantes y luego coloque los cajones de acuerdo con el siguiente diagrama.

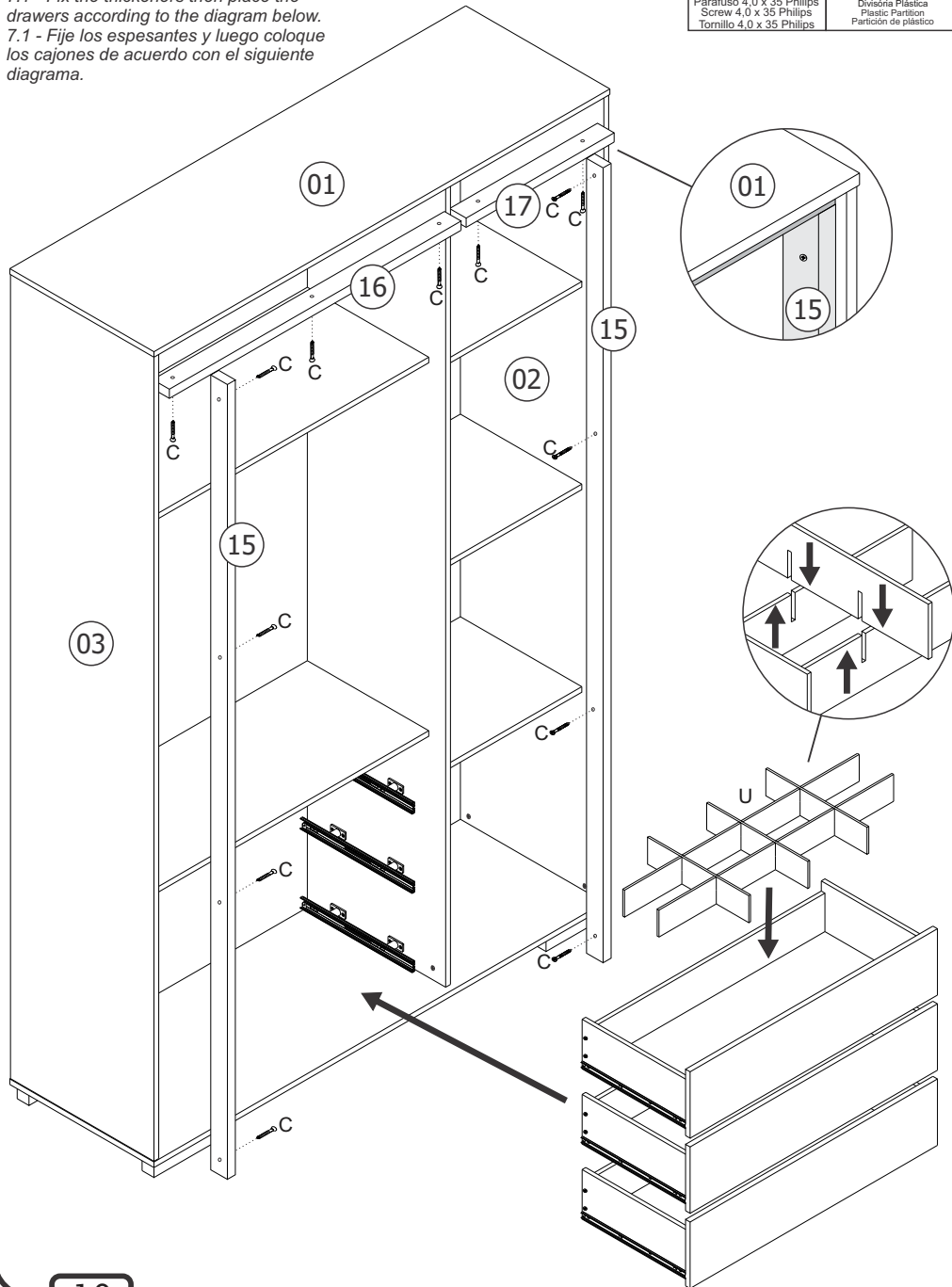
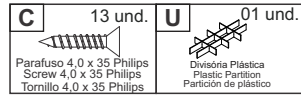

PESO SUPORTADO / DIMENSÕES PRODUTO MONTADO
SUPPORTED WEIGHT / DIMENSIONS ASSEMBLED PRODUCT
PESO SOPORTADO / DIMENSIONES PRODUCTO ARMADO

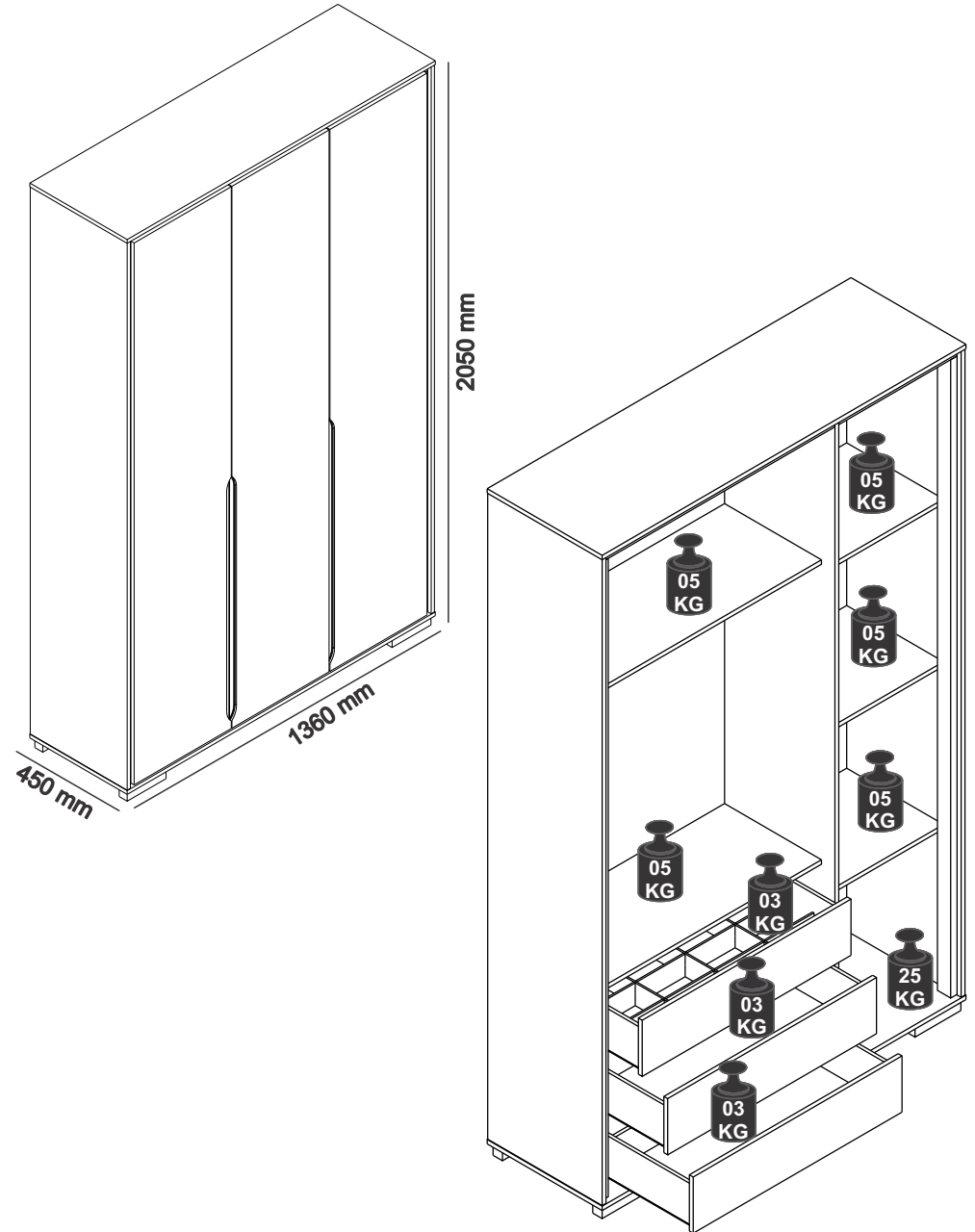

IDENTIFICAÇÃO DAS PEÇAS / IDENTIFICATION OF PARTS / IDENTIFICACIÓN DE LAS PIEZAS

CÓDIGO	IDENTIFICAÇÃO DAS PEÇAS	IDENTIFICATION OF PARTS	IDENTIFICACIÓN DE LAS PIEZAS	MEDIDAS (mm)				MAT.
				QTD	COMP	LARG	ESPES	
22819.001	Chapéu	Hat	Sombrero	1	1427	451	15	MDF
22819.002	Lateral Direita	Right side	Derecha-Atrás	1	2185	449	15	MDF
22819.003	Lateral Esquerda	Left-Back	Izquierda-Atrás	1	2185	449	15	MDF
22819.004	Divisória	Partition	Partición	1	2185	433	15	MDF
22820.005	Prateleira	Shelf	Estante	3	464	380	15	MDF
22820.006	Prateleira Maleiro	Maleiro Shelf	Maleiro Estante	1	914	380	15	MDF
22820.007	Tampo Gaveteiro	Top Drawer	Cajón Superior	1	914	380	15	MDF
22819.008	Base	Base	Base	1	1427	451	15	MDF
22820.009	Frente de Gaveta	Drawer Front	Frente del cajón	3	819	190	15	MDF
22821.010	Porta Direita	Right Door	Puerta derecha	2	2163	450	15	MDF
22821.011	Porta Esquerda	Left Door	Puerta izquierda	1	2163	450	15	MDF
22820.012	Lateral da Gaveta	Drawer Side	Lado del cajón	6	139	350	12	MDF
22820.013	Contra Fundo da gaveta	Against Drawer Bottom	Contra el fondo del cajón	3	110	780	12	MDF
22819.014	Distanciador do Gaveteiro	Drawer Spacer	Espaciador de cajones	2	654	52	25	MDF
22819.015	Engrosso Lateral	Side Thicken	Lado espesar	2	2158	52	25	MDF
22819.016	Engrosso Chapéu Maior	Bigger Hat Thicken	El sombrero grande espesa	1	913	52	25	MDF
22819.017	Engrosso Chapéu Menor	Thick Smaller Hat	Sombrero grueso pequeño	1	463	52	25	MDF
22820.018	Fundo de Gaveta	Drawer bottom	Fondo del cajón	3	814	356	3	MDF
22821.019	Fundo Maleiro	Maleiro Background	Fondo Maleiro	1	520	446	3	MDF
22821.020	Fundo Meio	Medium Background	Fondo medio	1	1014	446	3	MDF
22821.021	Fundo Gaveteiro	Drawer Background	Fondo de cajones	1	675	446	3	MDF
22821.022	Fundo Maior	Greater Fund	Fondo mayor	2	2209	446	3	MDF

FERRAGENS / IRONMONGERY / HERRAJES

A 12 und. Parafuso 5,0 x 50 CC Screw 5,0 x 50 CC Tornillo 5,0 x 50 CC	B 12 und. Parafuso 4,0 x 40 CC Screw 4,0 x 40 CC Tornillo 4,0 x 40 CC	C 19 und. Parafuso 4,0 x 35 Phillips Screw 4,0 x 35 Phillips Tornillo 4,0 x 35 Phillips	D 60 und. Parafuso 4,0 x 16 Flangeado Screw 4,0 x 16 Flanged Tornillo 4,0 x 16 Bridado	E 03 und. Parafuso 4,0 x 16 CC Screw 4,0 x 16 CC Tornillo 4,0 x 16 CC	F 30 und. Parafuso 3,0 x 20 CC Screw 3,0 x 20 CC Tornillo 3,0 x 20 CC	G 50 und. Parafuso 3,5 x 12 CC Screw 3,5 x 12 CC Tornillo 3,5 x 12 CC
H 82 und. Prego 8 x 8 Nail 8 x 8 Clavo 8 x 8	I 44 und. Cavilha 6 x 30 Dowel 6 x 30 Clavija 6 x 30	J 38 und. Parafuso Simples Minifix Simple Screw Minifix Tornillo Simples Minifix	K 38 und. Tambor Minifix Minifix Connector Conector Minifix	L 12 und. Dobradça Hinge Bisagra	M 02 und. Bucha ivasa 8mm 8mm ivasa bushing Casquillo ivasa 8 mm	N 05 und. Pés de Madeira Wood Feet Pies de Madera
O 10 und. Chapa União Fundo Insulation Pins Chapa prendedora	P 03 und. Cantoneira Triang. 14x14 Triangle Corner Brace 14 x 14 Abrazadera Plástica 14 x 14	Q 02 und. Suporte Bastão Cabideiro Plastic Bar Support Soporte Barra de Plástico	R 12 und. Distanciador Spacer Espaciador	S 03 und. Corrediza Telescópica 350mm Telescopic Sliding Rail 350mm Rieles Telescópicos 350mm	T 03 und. Corrediza Telescópica 350mm Telescopic Sliding Rail 350mm Rieles Telescópicos 350mm	U 01 und. Divisória Plástica Plastic Partition Partición de plástico
V 01 und. Perfil H 49,8 cm	X 01 und. Perfil H 99,4 cm	W 01 und. Perfil H 65,2 cm	Y 28 und. Tampa Adesiva 18mm Adhesive Label 18mm Tapa Adhesiva 18mm	A1 01 und. Etiqueta Label	A2 01 und. Bastão Cabideiro 905 mm Hanging Rail 905 mm Parchero 905 mm	A3 02 und. Alça de segurança Security tape Cinta de seguridad

FERRAGENS ESCALA REAL / REAL SCALE IRONMONGERY / HERRAJES EN TAMAÑO COMPLETO

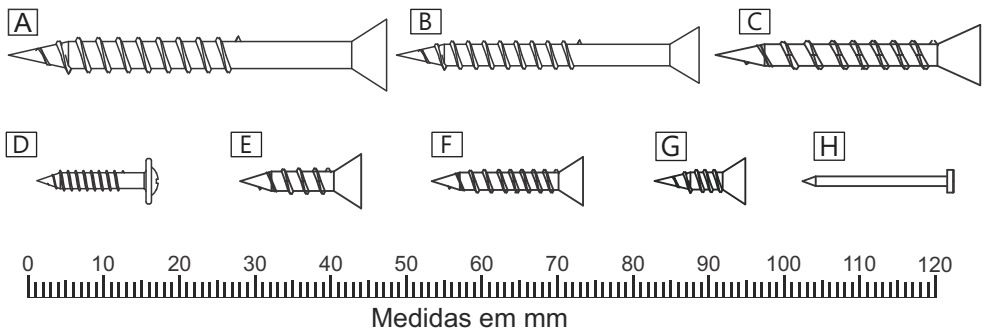

ASSISTÊNCIA TÉCNICA

Ao solicitar assistência técnica, informe o número da peça, nome, cor do produto e a data de fabricação do lote que se encontra carimbado na peça N° 18

TECHNICAL ASSISTANCE

When request the technical assistance, inform the number of the piece name and color of the product and also the batch manufacturing date, that is stamped on the piece n° 18

ASISTENCIA TÉCNICA

Al solicitar la asistencia técnica, informe el número de la pieza, el nombre y el color del producto y también la fecha de fabricación del lote, que se estampa en la pieza n° 18

Passo / Step / Paso 6:

6.1 - Encaixe primeiro a lateral depois as prateleiras, em seguida fixe as peças.

6.1 - Fit the side first, then the shelves, then fix the pieces.

6.1 - Ajuste primero el lado, luego los estantes, luego arregle las piezas.

6.2 - Fixe o tampo e os acessórios igual esquema a seguir.

6.2 - Attach the worktop and accessories in the same diagram below.

6.2 - Fije la encimera y los accesorios en el mismo diagrama a continuación.

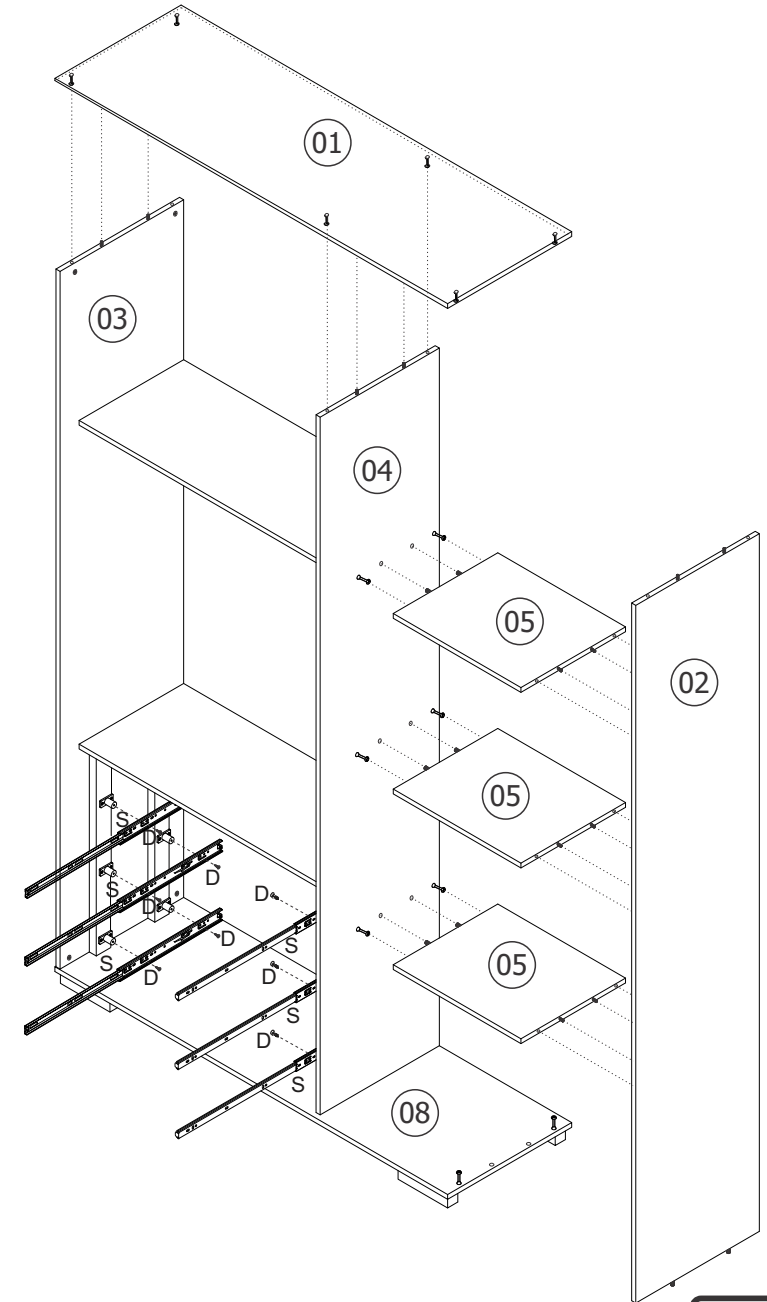
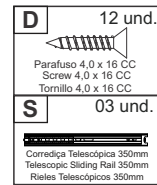

Passo / Step / Paso 4:

4.1 - Faça a montagem conforme esquema a seguir.
 4.1 - Make the assembly according to the diagram below.
 4.1 - Realice el montaje de acuerdo con el siguiente diagrama.

4.2 - Para a montagem da peça 14 seguir marcação da lateral.
 4.2 - To assemble part 14, follow the side marking.
 4.2 - Para ensamblar la parte 14, siga la marca lateral.

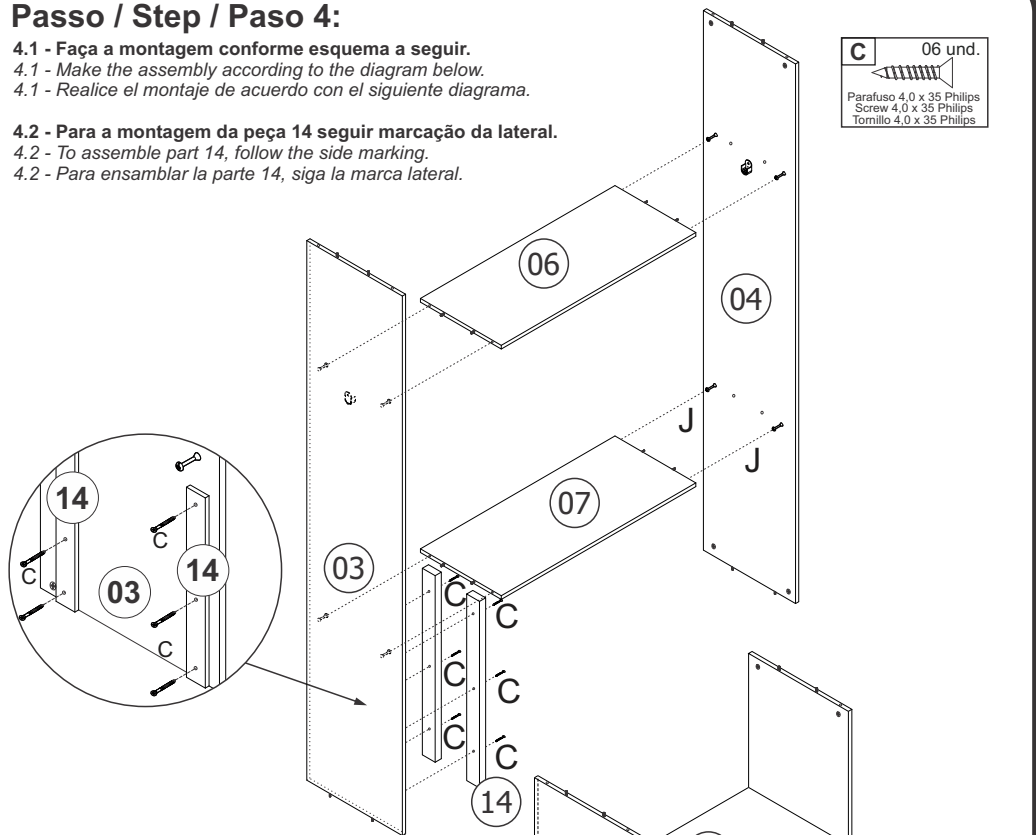
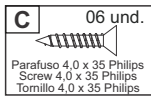

Passo / Step / Paso 5:

5.1 - Fixe as laterais na base depois fixe os acessórios conforme esquema a seguir.

5.1 - Fix the sides on the base then fix the accessories according to the diagram below.

5.1 - Fije los lados de la base y luego fije los accesorios de acuerdo con el siguiente diagrama.

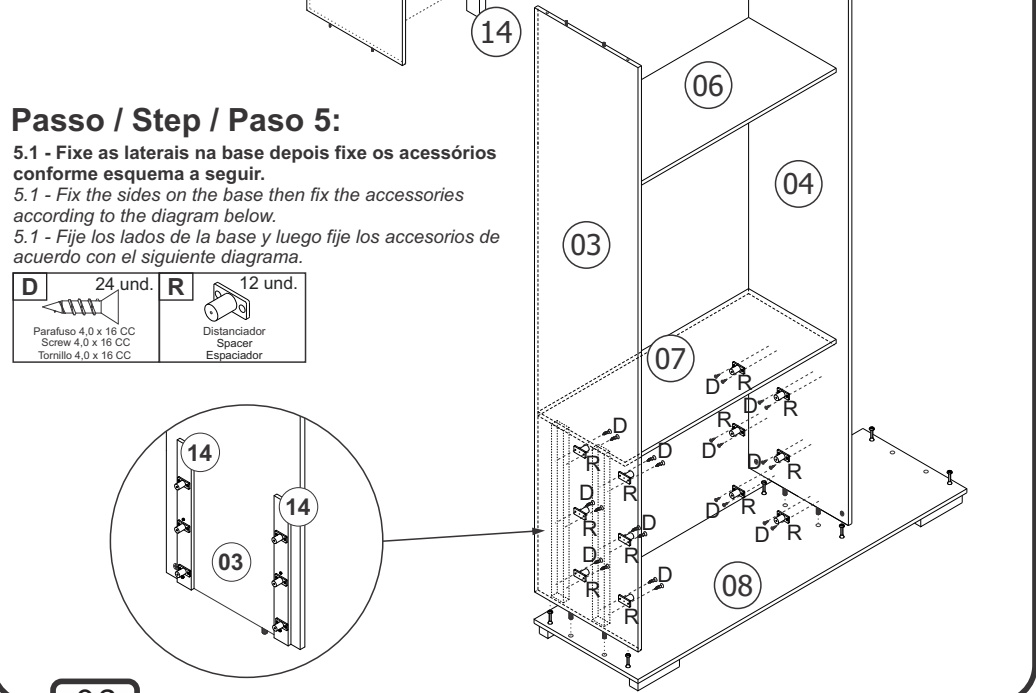
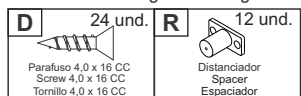

IDENTIFICAÇÃO DAS PEÇAS / IDENTIFICATION OF PARTS / IDENTIFICACIÓN DE LAS PIEZAS

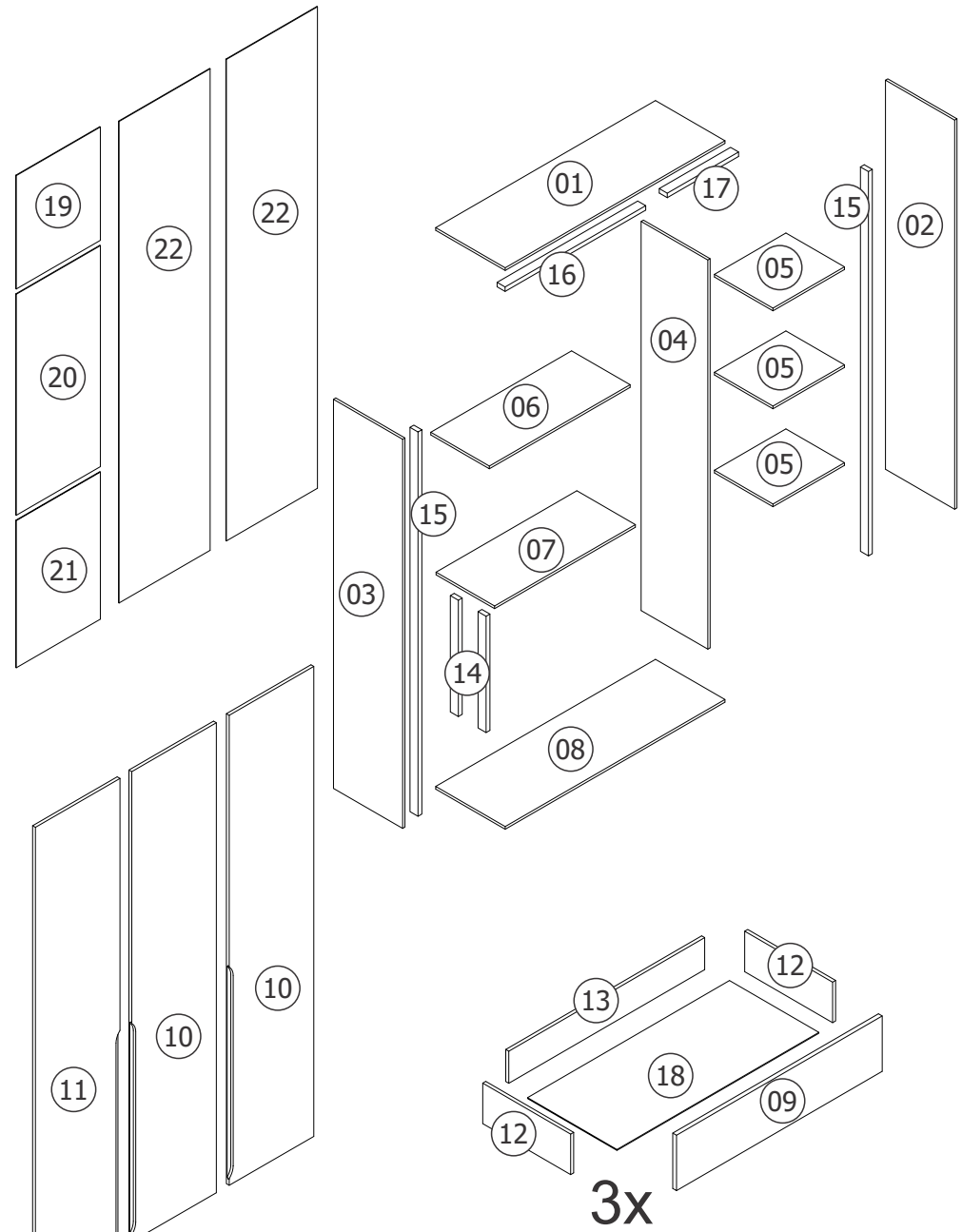

Passo / Step / Paso 1:

- 1.1 - Prepare as peças conforme esquema a seguir.
 1.1 - Prepare the parts according to the diagram below.
 1.1 - Prepare las piezas de acuerdo con el siguiente diagrama.

G 04 und. Parafuso 3,5 x 12 CC Screw 3.5 x 12 CC Tornillo 3.5 x 12 CC	I 44 und. Cavilha 6 x 30 Dowel 6 x 30 Clavija 6 x 30
J 34 und. Parafuso Simples Minifix Simple Screw Minifix Tornillo Simples Minifix	K 38 und. Tambor Minifix Minifix Connector Conector Minifix
Q 02 und. Suporte Bastão Cabideiro Plastic Bar Support Soporte Barra de Plástico	

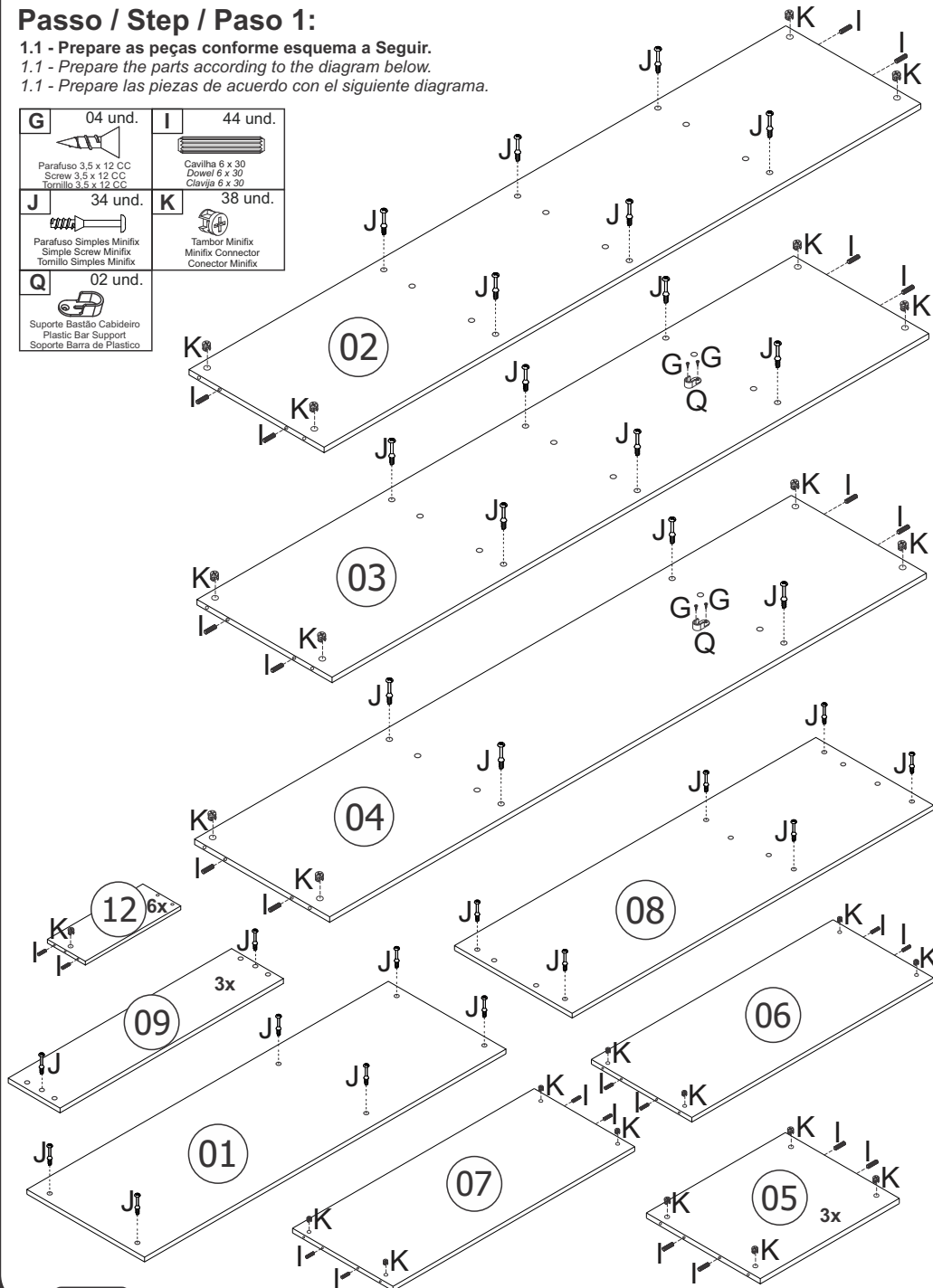

Passo / Step / Paso 2:

- 2.1 - Fixe as peças conforme esquema a seguir.
 2.1 - Fix the parts according to the diagram below.
 2.1 - Arregle las partes de acuerdo con el siguiente diagrama.

A 10 und. Parafuso 5,0 x 50 CC Screw 5.0 x 50 CC Tornillo 5.0 x 50 CC	N 05 und. Pés de Madeira Wood Feet Pies de Madera
---	---

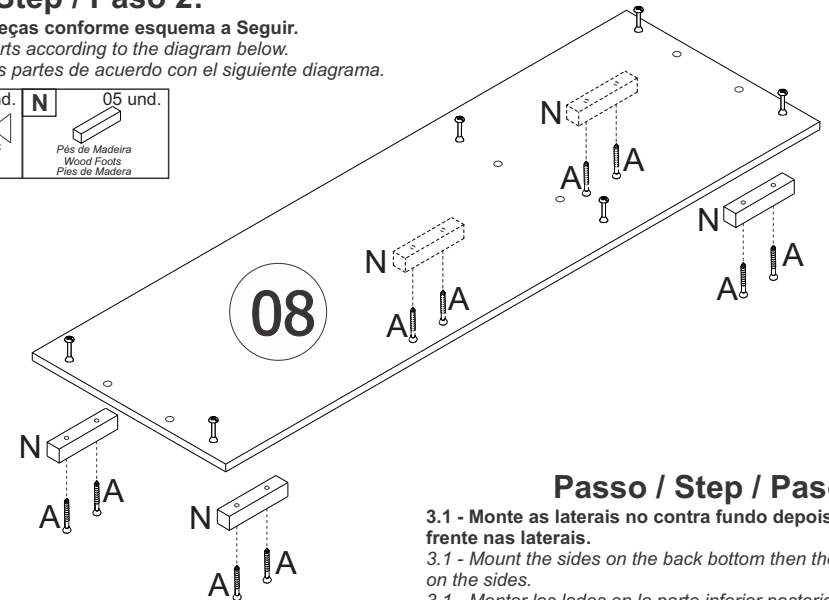

3.1

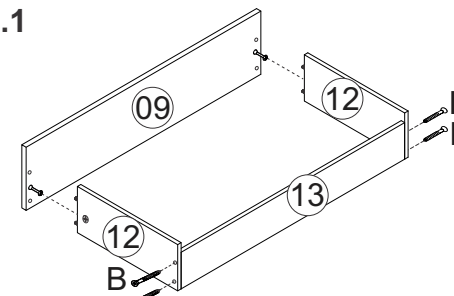

3.2

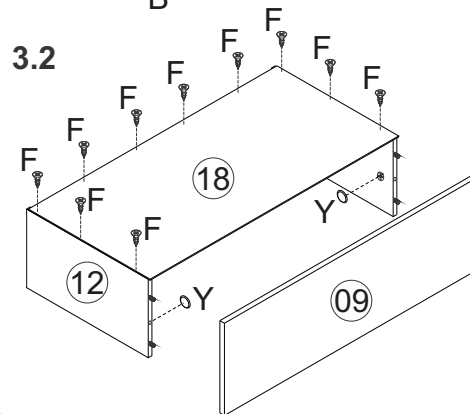

Passo / Step / Paso 3:

- 3.1 - Monte as laterais no contra fundo depois a frente nas laterais.
 3.1 - Mount the sides on the back bottom then the front on the sides.
 3.1 - Montar los lados en la parte inferior posterior y luego el frontal en los lados.

- 3.2 - Monte o fundo no corpo da gaveta.
 3.2 - Mount the bottom on the drawer body.
 3.2 - Monte la parte inferior en el cuerpo del cajón.

- 3.3 - Fixe as corredeiras na lateral.
 3.3 - Fix the slides on the side.
 3.3 - Fijar las diapositivas en el lateral.

B 12 und. Parafuso 4,0 x 40 CC Screw 4.0 x 40 CC Tornillo 4.0 x 40 CC	E 03 und. Parafuso 4,0 x 16 CC Screw 4.0 x 16 CC Tornillo 4.0 x 16 CC	F 30 und. Parafuso 3,0 x 20 CC Screw 3.0 x 20 CC Tornillo 3.0 x 20 CC
G 18 und. Parafuso 3,5 x 12 CC Screw 3.5 x 12 CC Tornillo 3.5 x 12 CC	P 03 und. Cantoneira Triang. 14x14 Triangle Corner Brace 14 x 14 Abrazadera Plástica 14 x 14	T 03 und. Correção Telescópica 400mm Telescopic Sliding Rail 400mm Reles Telescópicos 400mm
Y 06 und. Tampa Adesiva 18mm Adhesive Label 18mm Tapa Adhesiva 18mm		

3.3

