

Item	Caixa Caja Box	Qtd Ctd Qty	Descrição Descripción Description	Medidas (mm) Dimensions (mm) Size (measurements) (mm)
01	2/3	01	Rodapé frontal delante de pie de página Front footer	1308x45x15
02	2/3	01	Rodapé traseiro Pie de página trasera Rear footer	1308x45x15
03	2/3	02	Rodapé lateral Pie de página lado Side Footer	318x45x15
04	1/3	04	Pés Pies Foot	110x45x45
05	2/3	01	Base Base Base	1400x410x15
06	2/3	01	Tampo das Gavetas Tapa de los cajones Drawer Top	1369x410x15
07	2/3	01	Divisão División Division	1142x410x15
08	1/3	01	Divisão das gavetas División de los cajones Division of drawers	503x410x15
09	1/3	01	Lateral esquerda Lateral izquierda Left side	2080x410x15
10=13	1/3	01	Prateleira Estante Shelf	677x400x15
11	2/3	01	Ripa do Maleiro Tablilla Maleiro Maleiro clapboard	350x60x15
12	2/3	01	Chão do Maleiro Maleiro's Ground Maleiro's Ground	1369x410x15
13=10	1/3	02	Prateleira Estante Shelf	677x400x15
14	1/3	01	Lateral direita Lateral derecha Right side	2080x410x15
15	2/3	01	Tampo Tapa Top	1369x410x15
16	2/3	01	Fundo Superior Fondo superior Upper Fund	1393x369x3
17	1/3	04	Fundo Fondo Fund	1156x345x3
18	2/3	01	Fundo Inferior Cru Fondo inferior crudo Raw Bottom Bottom	1393x522x3
19	2/3	01	Chapéu Sombrero Hat	1398x45x15
20	3/3	04	Porta Puerta Door	1517x342x15
21	2/3	04	Aplique Porta Aplicar puerta Apply Door	575x45x6
22	1/3	02	Frente de gaveta superior Frente del cajón superior Top drawer front	687x250x15
23	2/3	04	Aplique Gaveta Aplicar cajón Apply Drawer	475x45x6
24	1/3	08	Lado de gaveta Lado del cajón Side of drawer	350x122x15
25	1/3	04	Fundo de gaveta Fondo del cajón Drawer bottom	633x361x3
26	1/3	04	Ripa de trás Malla detrás Rear lath	652x122x15
27	1/3	01	Pé Madeira Pie de madera Foot Wood	110x45x45
28	1/3	02	Frente de gaveta inferior Frente del cajón inferior Lower drawer front	687x250x15

Ferragens | Herrajes | Hardware

A Cantoneira de metal Soporte de metal Metal bracket	B Parafuso 4,0x25mm FLA MET Tornillo 4,0x25mm FLA MET Screw 4,0x25mm FLA MET	C Parafuso 3,5x40mm CHT. Tornillo 3,5x40mm CHT. Screw 3,5x40mm CHT.	D Parafuso 3,5x14mm FLA. Tornillo 3,5x14mm FLA. Screw 3,5x14mm FLA.	E Parafuso 3,5x12mm CHT. Tornillo 3,5x12mm CHT. Screw 3,5x12mm CHT.	F Parafuso 3,0x30mm CHT. Tornillo 3,0x30mm CHT. Screw 3,0x30mm CHT.	G Cavilha 8x25mm Cinta 8x25mm Dowel 8x25mm
H Parafuso 3,0x16mm CHT. Tornillo 3,0x16mm CHT. Screw 3,0x16mm CHT.	I Giz de correção Tiza de corrección Chalk of correction	J Parafuso minifix Tornillo minifix Minifix bolt	K Tambor minifix Tambor minifix Minifix drum	L Porca sextavada Tuerca hexagonal Hexagon nut	M Suporte cabideiro Soporte de percha Coat hanger support	N Cantoneira suporte triangular Cantoneira soporte triangular Triangle support angle
O Cantoneira plástica Cantoneira plástica Plastic angle brackets	P Fixador de fundos Fijador de fondos Bottom fixer	Q Prego 10x10mm Clavo 10x10mm Nail 10x10mm	R Dobradiça metal 26mm Bisagra de metal 26mm 26 mm metal hinge	S Calço metal 5mm Calzado metálico 5mm 5 mm metal shim	T Corrediça telescópica Corredera telescópica Telescopic slide	U Sachê de cola Bolsa de pegamento Glue bag
V Cabideiro Alum. 669mm Alu 669mm percha Alu coat hanger 669mm	W Perfil "H" 1148mm Perfil "H" 1148mm Profile "H" 1148mm	X Perfil "I" 1370mm Perfil "I" 1370mm Profile "I" 1370mm	Y Adesivo tapa parafuso 10mm Adhesivo tapón de tornillo 10mm Bolt cover adhesive 10mm	Z Etiqueta resinada Henn Etiqueta resinada Henn Henn resin label		



Ind. e Com. de Móveis Henn
Mondai - SC - Brasil
+55 49 3674.3500
@moveishenn
www.henn.com.br

INSTRUÇÕES DE MONTAGEM

INSTRUCCIONES DE MONTAJE
ASSEMBLY INSTRUCTIONS

Roupeiro Alegria 04 Portas | Ropero Alegria 04 Puertas |
Wardrobe Alegria 04 Doors

- I116-05 - Branco HP
- I116-131 - Cinza

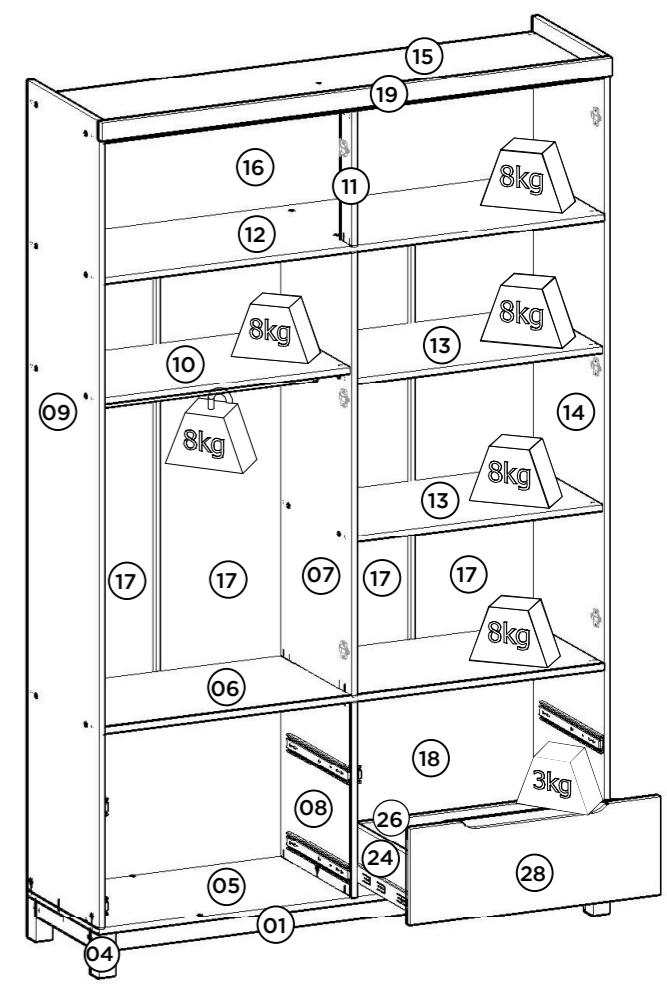
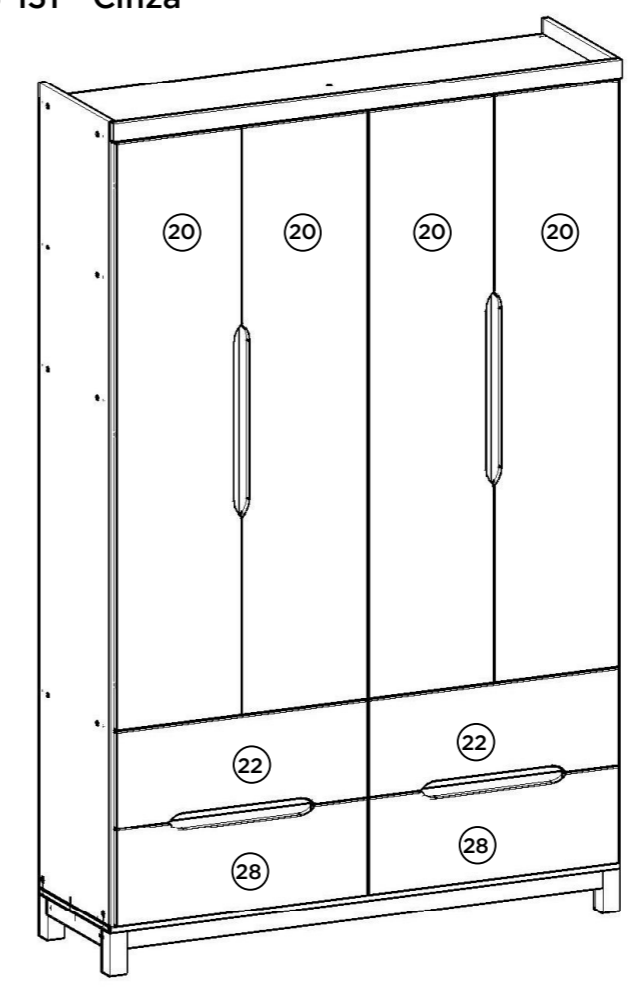

Pesos máximos recomendados com carga distribuída
Peso máximo recomendado con la carga distribuida
Recommended maximum weights with evenly distributed.

Requisitos para montagem
Requisitor para la montaje
Assembly Requirements

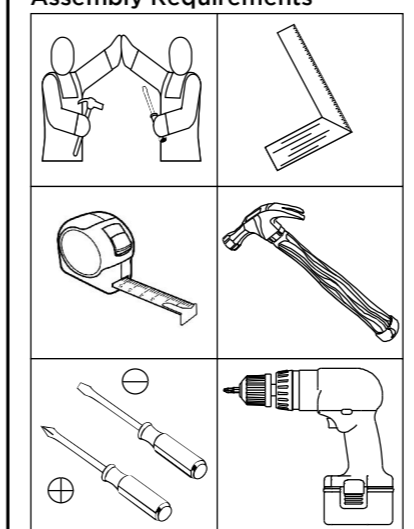

Imagens meramente ilustrativas
Imágenes meramente ilustrativas
Images for illustration only

AVISO

Para limpeza de seu móvel, use uma flanela seca ou umedecida, e não utilize produtos químicos que possam danificar seu produto.

SISTEMA DE MONTAGEM

O sistema de montagem dos produtos, funciona de acordo com a ordem crescente dos números indicados no desenho. Ex: 01, 02, 03, 04... até a conclusão da montagem.

ADVERTENCIA

Para limpieza de su móvil, use una flanela seca o húmeda, y no utilice productos químicos que puedan dañar su producto.

SISTEMA DE MONTAJE

El sistema de montaje de los productos funciona de acuerdo con el orden creciente de los números indicados en el dibujo. Ej.: 01, 02, 03, 04... hasta la conclusión del montaje.

NOTICE

To clean your furniture, use a dry or wet cloth, and do not use chemicals that may damage your product.

ASSEMBLY SYSTEM

The products' assembly system works according to the increasing order of the indicated numbers. For example: 01, 02, 03, 04 ... to the end of the assembly.

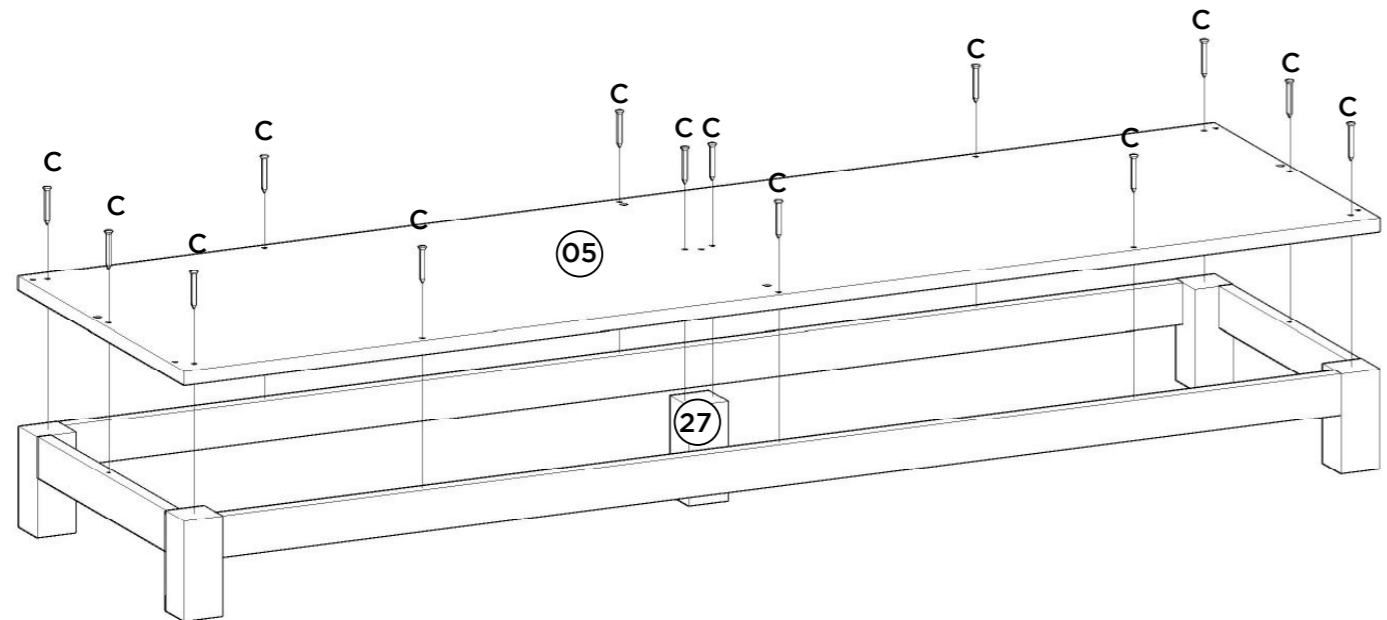
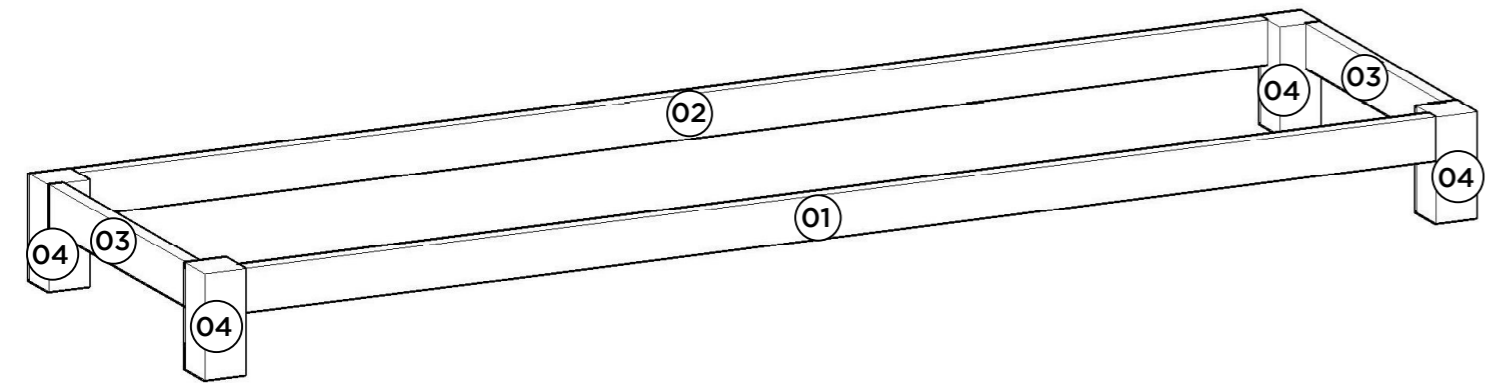
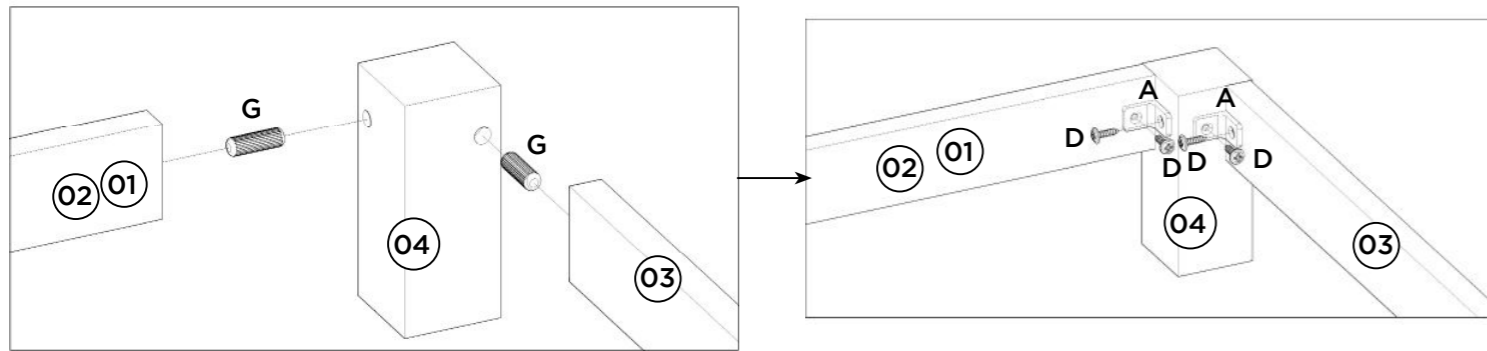

Montagem gaveta Inferior e Superior 4x
 Conjunto de cajones inferior y superior 4x
 Lower and Upper 4x drawer assembly

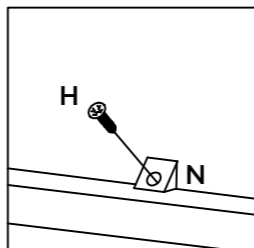
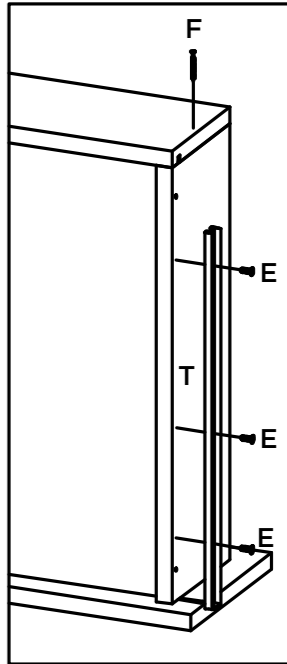
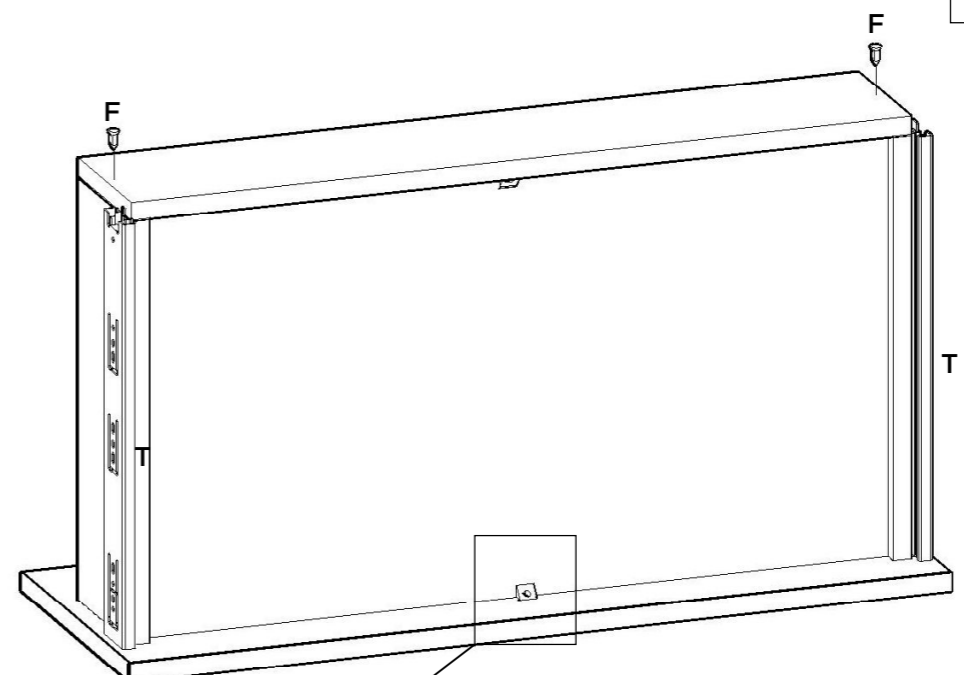
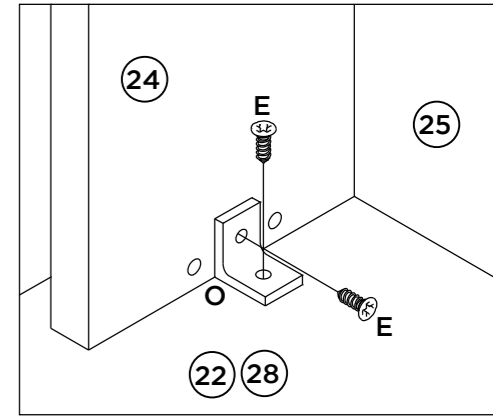
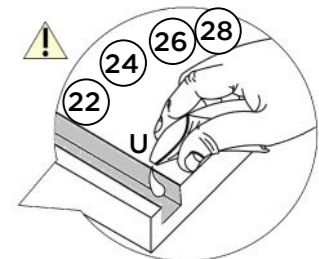
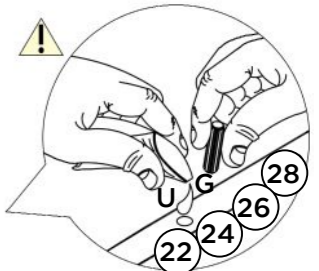
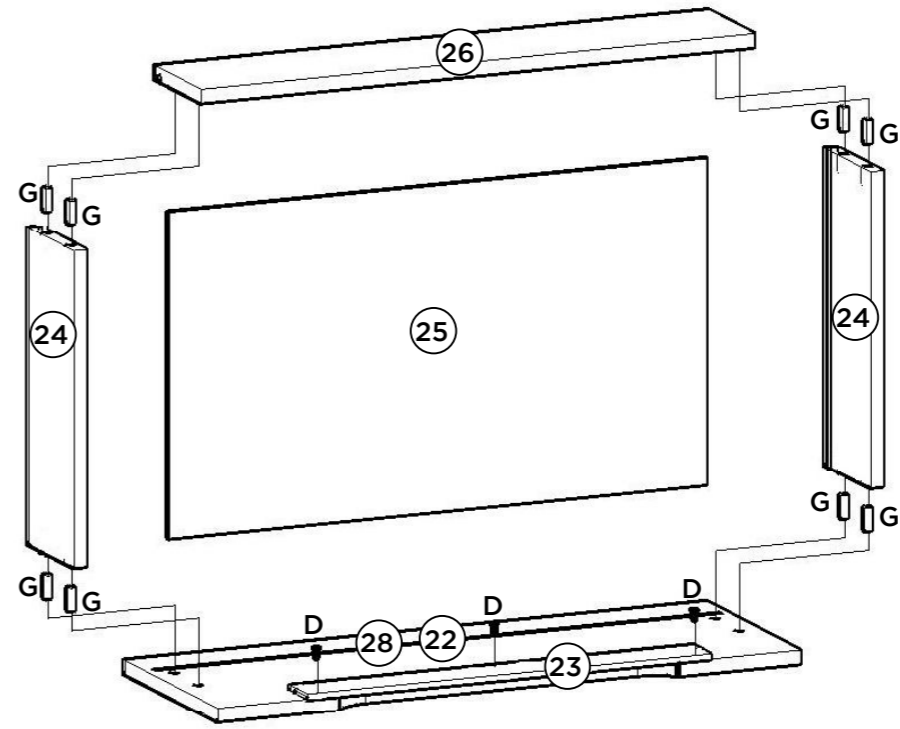

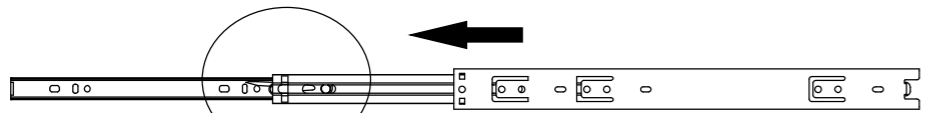

Para a desmontagem da correia siga a instrução ao lado.

Para el desmontaje seguimiento de diapositivas la instrucción siguiente a.

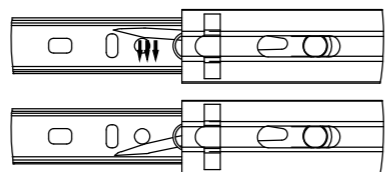

Fixar as correias nessas furações
Fijar las diapositivas de estos agujeros

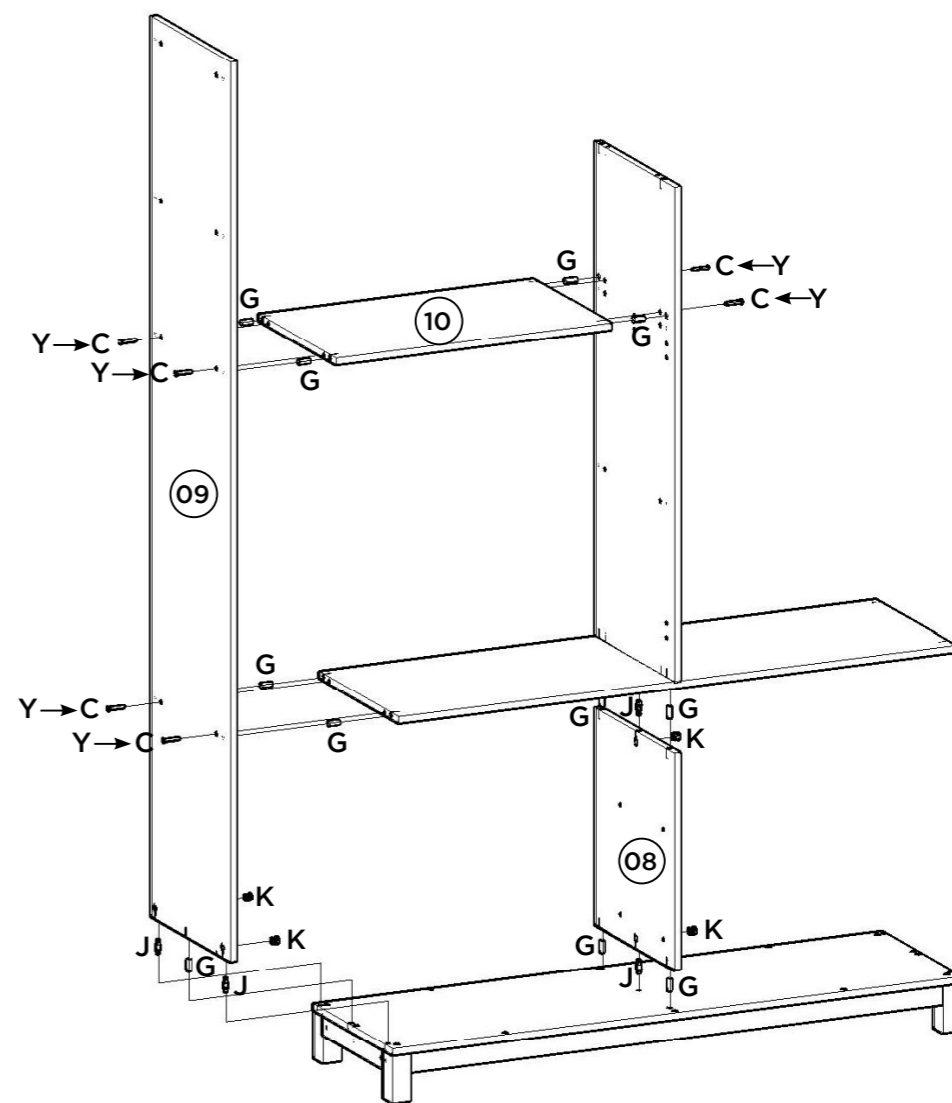
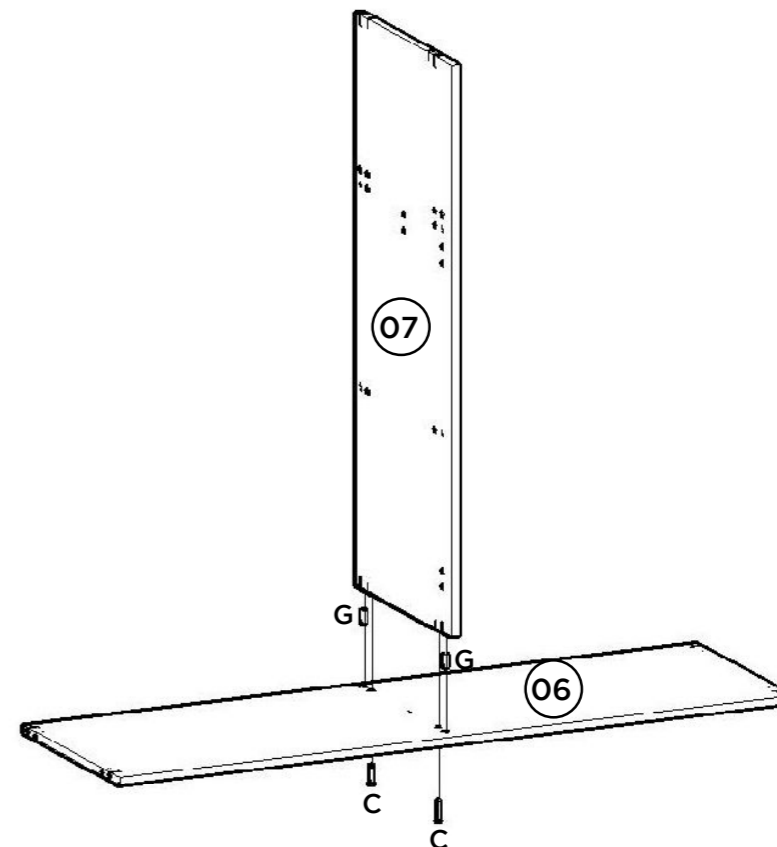
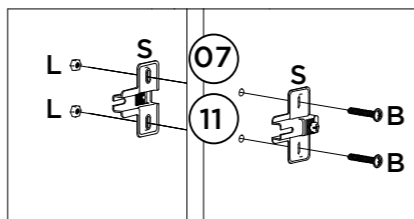
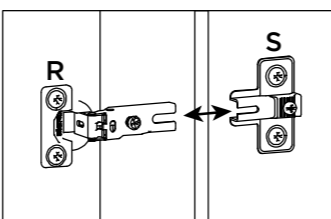
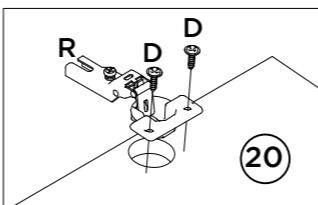
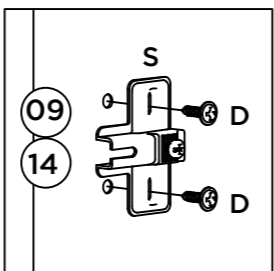
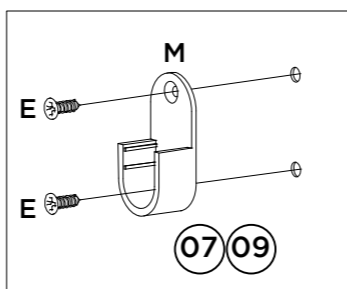
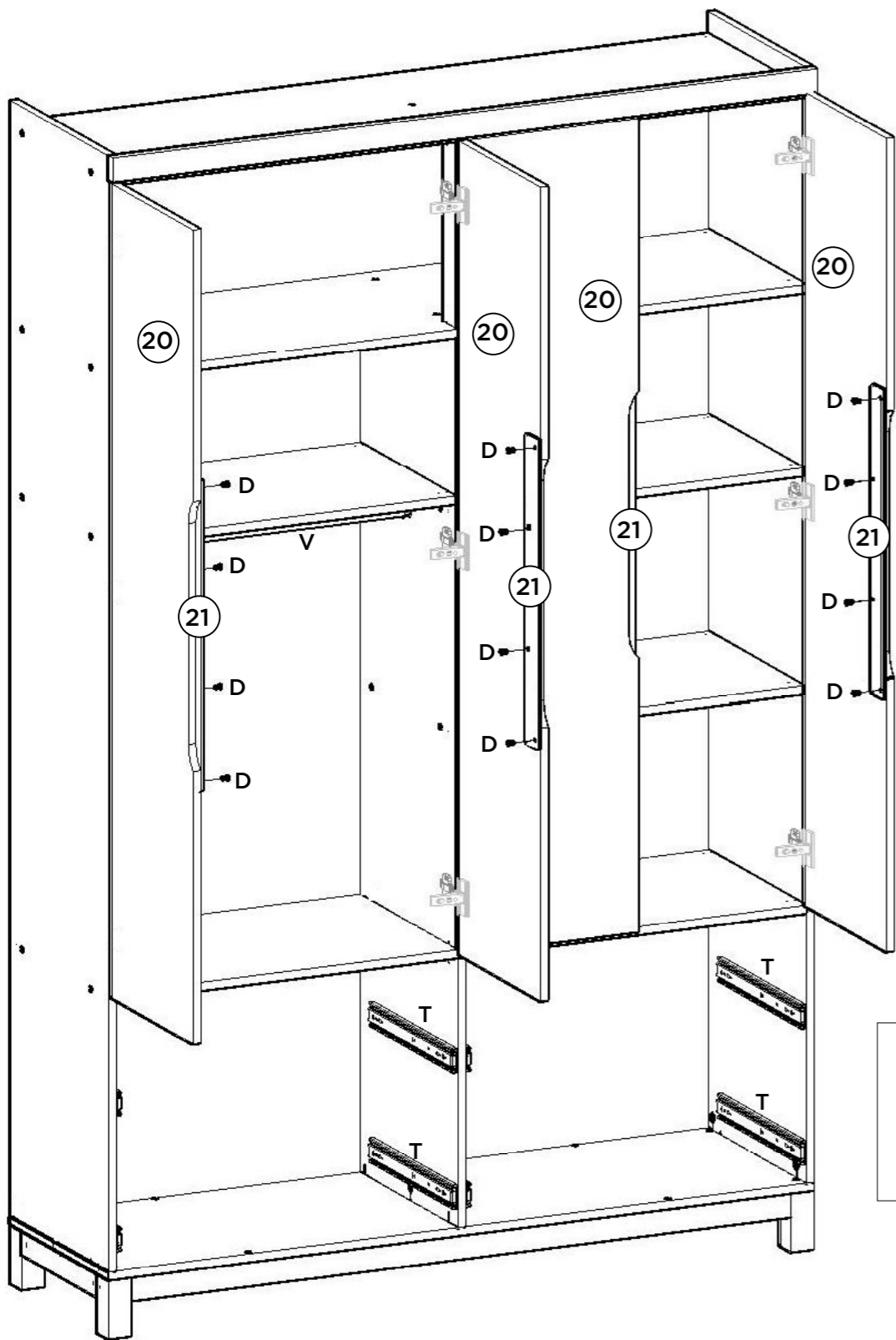

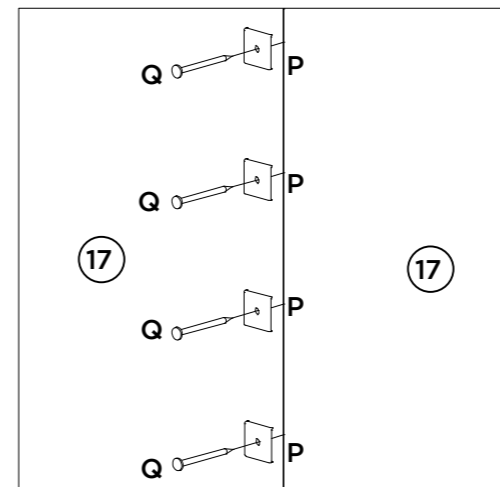
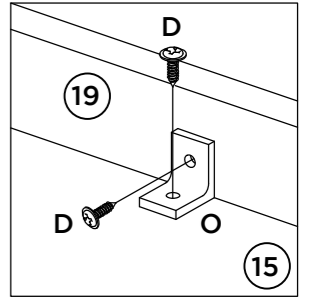
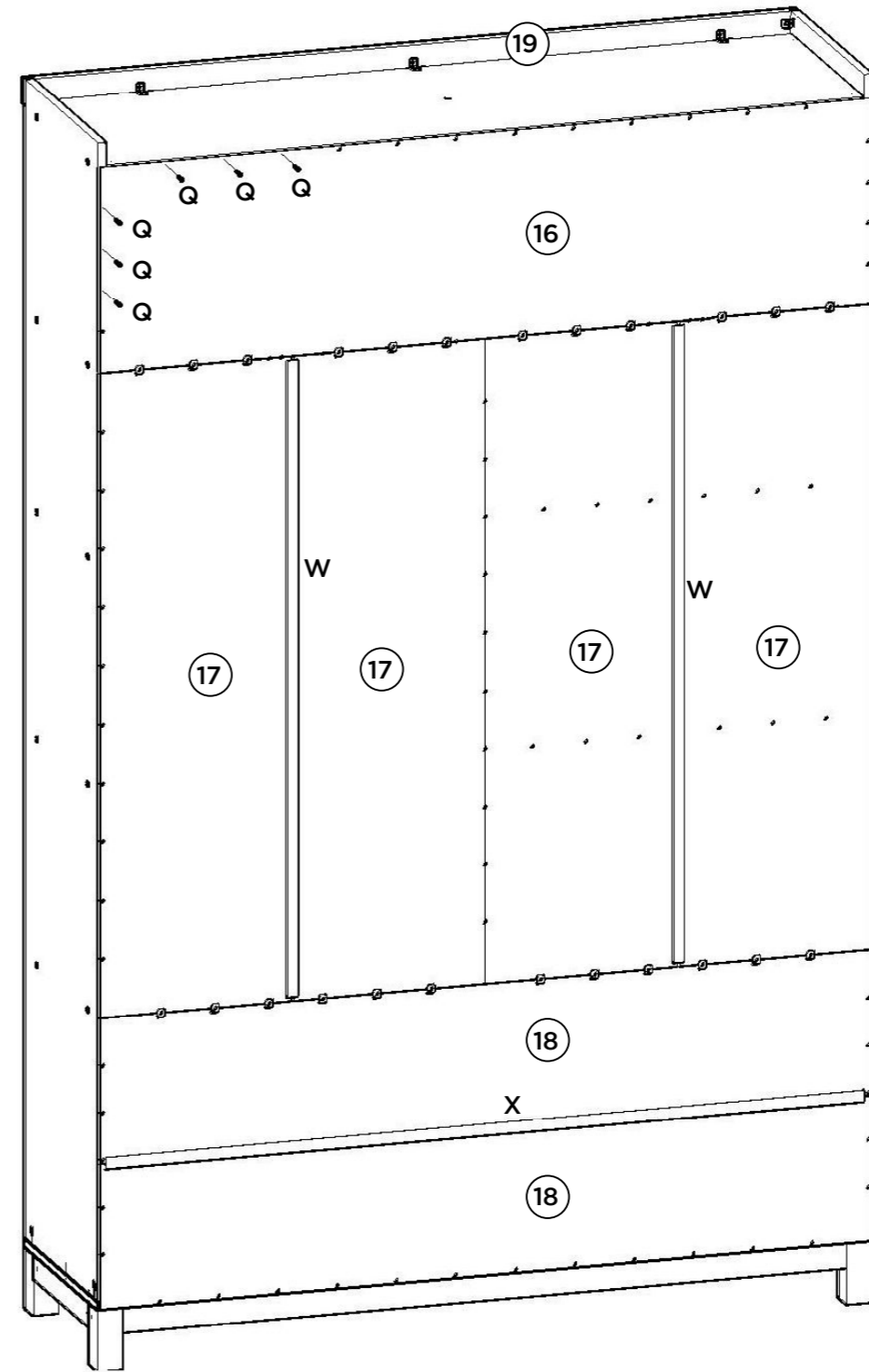
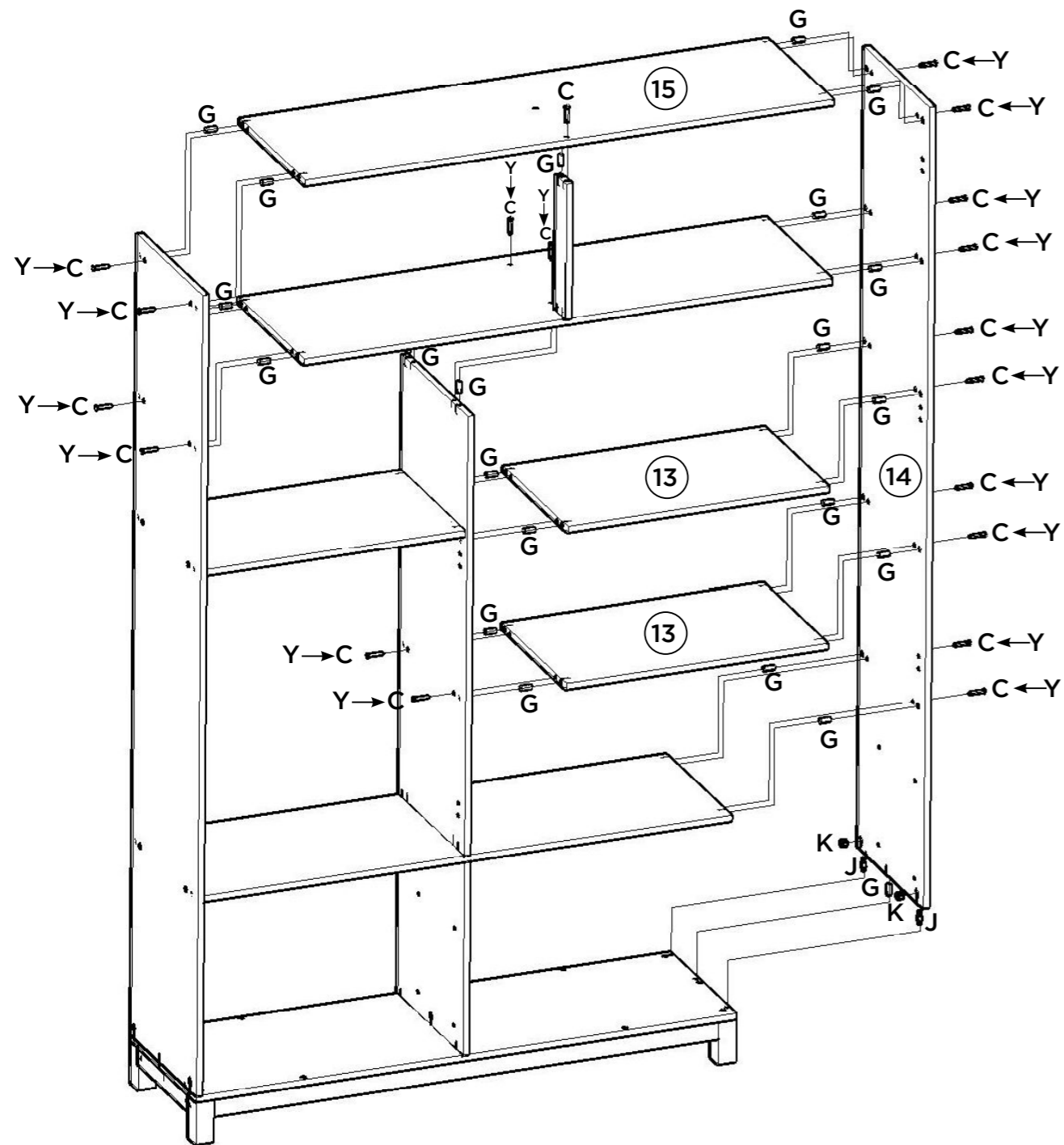
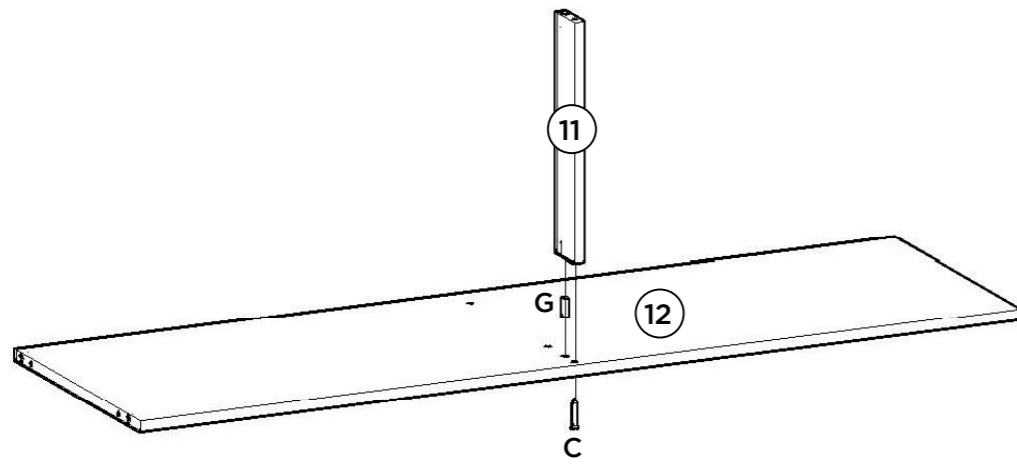

- Fixar os pregos (Q) a 100mm de distância um para outro.
- Fijar los clavos (Q) a 100mm de distancia entre sí.
- Fasten the nails (Q) to 100mm distance from each other.

