

Item	Caixa Box	Qtd Qty	Descrição / Descripción / Description	Medidas (mm) / Dimensions (mm) / Size (measurements) (mm)
01	1/2	01	Rodapé frontal / Rodapié frontal / Front footboards	1599x120x12
02	1/2	01	Travessa do rodapé / Carril pie / Footboard tray	415x120x12
03	1/2	01	Rodapé traseiro / Rodapié trasero / Rear footboard	1599x120x12
04=08	1/2	01	Base / Base / Base	537x445x12
05	1/2	01	Lateral esquerda / Lateral izquierda / Left side	1950x445x15
06	2/2	01	Divisão esquerda / División izquierda / Left division	1730x445x12
07	1/2	03	Prateleira fixa / Estante fija / Fixed shelf	525x350x12
08=04	1/2	01	Base / Base / Base	537x445x12
09	2/2	01	Divisão direita / División derecha / Right division	1730x445x12
10	1/2	01	Moldura frontal / Cornija frontal / Front frame	525x80x12
11	1/2	01	Tampo das gavetas / Tapa de los cajones / Drawers cover	525x445x12
12	1/2	01	Prateleira / Estante / Shelf	525x350x12
13=16	1/2	01	Moldura Inf Sup / Cornija Inf Sup / Bottom top frame	379x88x15
14	1/2	02	Moldura lateral / Cornija lateral / Side frame	927x73x15
15	2/2	01	Espelho / Espejo / Mirror	750x400x3
16=13	1/2	01	Moldura Inf Sup / Cornija Inf Sup / Bottom top frame	379x88x15
17	1/2	01	Lateral direita / Lateral derecha / Right side	1950x445x15
18	1/2	01	Prateleira do varão / Hombre estante / Rail shelf	525x200x12
19	1/2	01	Tampo superior / Cubierta superior / Top cover	1599x445x12
20	2/2	01	Chapéu / Sombrero / Hat	1627x80x15
21	2/2	02	Fundo / Fondo / Bottom	1754x542x3
22	2/2	01	Fundo menor / Fondo menos / Smaller bottom	536x236x3
23	2/2	01	Fundo cru / Fondo sin procesar / Raw bottom	577x536x3
24	2/2	04	Porta / Puerta / Door	1738x265x15
25	1/2	03	Frente de gaveta / Frente del cajón / Drawer front	533x160x15
26	1/2	06	Lado de gaveta / Lado del cajón / Drawer side	350x100x12
27	2/2	03	Ripa de trás / Listón trasero / Rear batten	500x100x12
28	2/2	03	Fundo de gaveta / Fondo del cajón / Drawer bottom	499x367x3



INSTRUÇÕES DE MONTAGEM

INSTRUCCIONES DE MONTAJE
ASSEMBLY INSTRUCTIONS

Roupeiro 04 Portas 03 Gavetas / Armario 04 Puertas 03 Cajones /
Wardrobe 04 Doors 03 Drawers

- B24-03 Chocolate
- B24-66 Branco/Branco/Rosa Chá
- B24-74 Gris/Palha
- B24-85 Moka/Fendi
- B24-94 Rústico

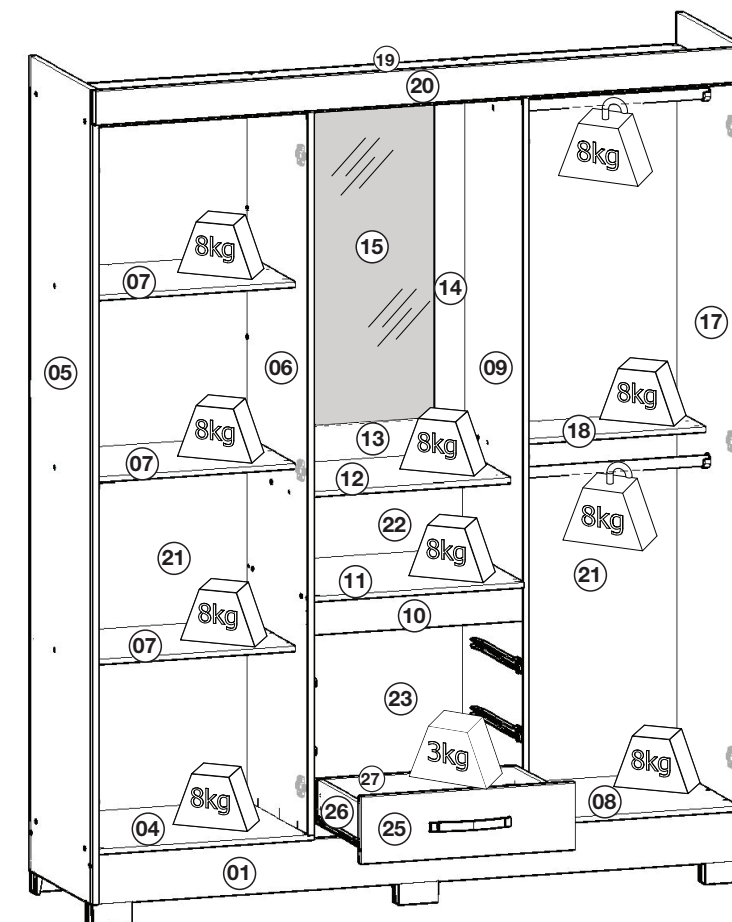
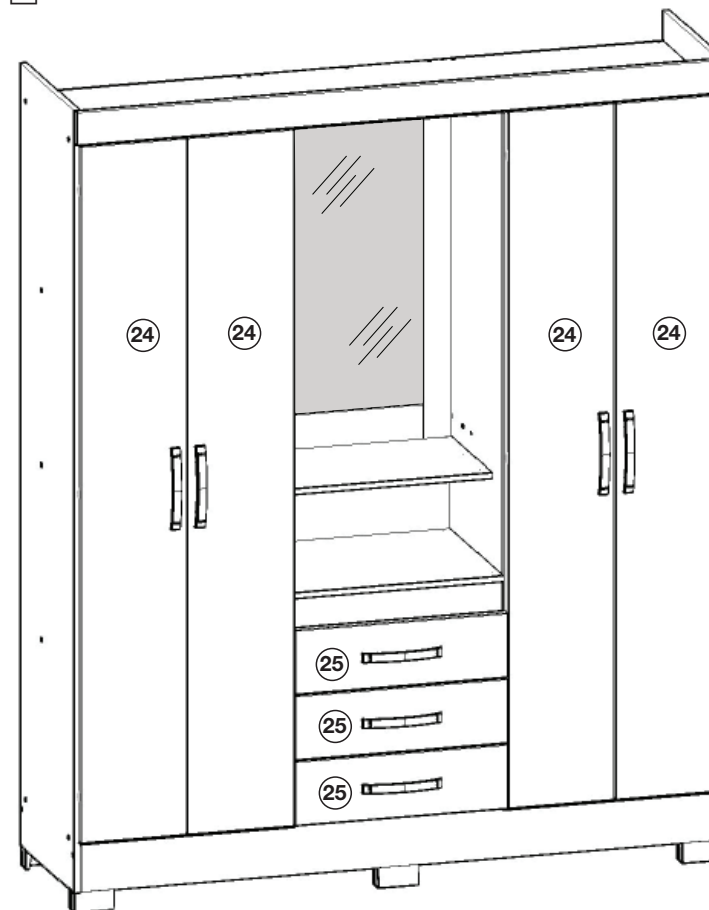

FERRAGENS / HERRAJES / HARDWARE

A 04x	B 32x	C 14x	D 106x	E 18x	F 24x	G 84x
Parafuso 4,5x50mm CHT. Tornillo 4,5x50mm CHT. Screw 4,5x50mm CHT.	Parafuso 3,5x40mm CHT. Tornillo 3,5x40mm CHT. Screw 3,5x40mm CHT.	Parafuso 3,5x25mm FLA. Tornillo 3,5x25mm FLA. Screw 3,5x25mm FLA.	Parafuso 3,5x12mm FLA. Tornillo 3,5x12mm FLA. Screw 3,5x12mm FLA.	Parafuso 3,5x12mm CHT. Tornillo 3,5x12mm CHT. Screw 3,5x12mm CHT.	Parafuso 3,0x16mm CHT. Tornillo 3,0x16mm CHT. Screw 3,0x16mm CHT.	Cavilha 5x25mm Cinta 5x25mm Dowel 5x25mm
H 19x	I 06x	J 110x	K 16x	L 12x	M 12x	N 03x
Fixador de fundos Fijador de fondos Bottom fixer	Prego 12x12mm Anelado Clavo 12x12mm Anillado Ringed Nails 12x12mm	Prego 10x10mm Clavo 10x10mm Nail 10x10mm	Cantoneira plástica Cantонера plástica Plastic angle brackets	Calço metal 5mm Calzado metálico 5mm 5 mm metal shim	Dobradiça metal 26mm Bisagra de metal 26mm 26 mm metal hinge	Corrediça metal 350mm Corredera de metal 350mm Sliding metal 350mm
O 04x	P 06x	Q 07x	R 04x	S 02x	T 04x	U 02x
Porca cilíndrica Tuerca cilíndrica Cylindrical nut	Pé "U" 50x40x100mm Pie "U" 50x40x100mm 50x40x100mm "U" feet	Puxador Indonésia 128mm Tirador Indonésia 128mm 128mm Indonésia Handle	Suporte cabideiro Soporte de percha Coat hanger support	Cabideiro Madeira 519mm Cabezal Madera 519mm 519mm wooden hanger	Suporte de metal Soporte de metal Metal stands	Sachê de cola Bolsa de pegamento Glue bag
V 01x	W 35x					
Etiqueta resinada Briz Etiqueta resinada Briz Briz resin label	Adesivo tapa parafuso 10mm Adhesivo tapón de tornillo 10mm Bolt cover adhesive 10mm					

AVISO

Para limpeza de seu móvel, use uma flanela seca ou umedecida, e não utilize produtos químicos que possam danificar seu produto.

SISTEMA DE MONTAGEM

O sistema de montagem dos produtos, funciona de acordo com a ordem crescente dos números indicados no desenho. Ex: 01, 02, 03, 04... até a conclusão da montagem.

ADVERTENCIA

Para limpieza de su móvil, use una flanela seca o húmeda, y no utilice productos químicos que puedan dañar su producto.

SISTEMA DE MONTAJE

El sistema de montaje de los productos funciona de acuerdo con el orden creciente de los números indicados en el dibujo. Ej.: 01, 02, 03, 04... hasta la conclusión del montaje.

NOTICE

To clean your furniture, use a dry or wet cloth, and do not use chemicals that may damage your product.

ASSEMBLY SYSTEM

The products' assembly system works according to the increasing order of the indicated numbers. For example: 01, 02, 03, 04 ... to the end of the assembly.

Requisitos para montagem

Requisitor para la montaje
Assembly Requirements

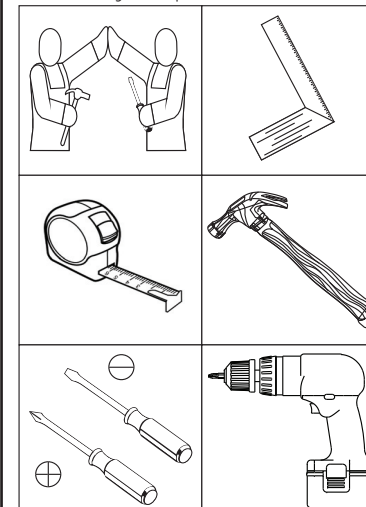

Imagens meramente ilustrativas
Imágenes meramente ilustrativas
Images for illustration only

Pesos máximos recomendados com carga distribuída

Peso máximo recomendado con la carga distribuida
Recommended maximum weights with evenly distributed.

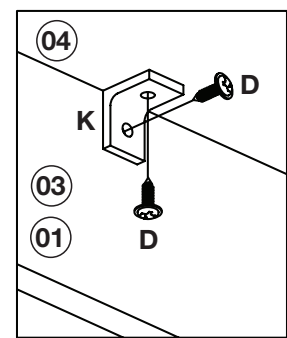
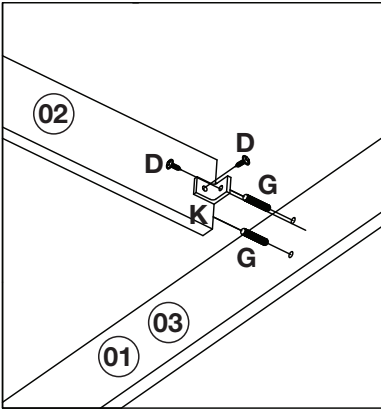
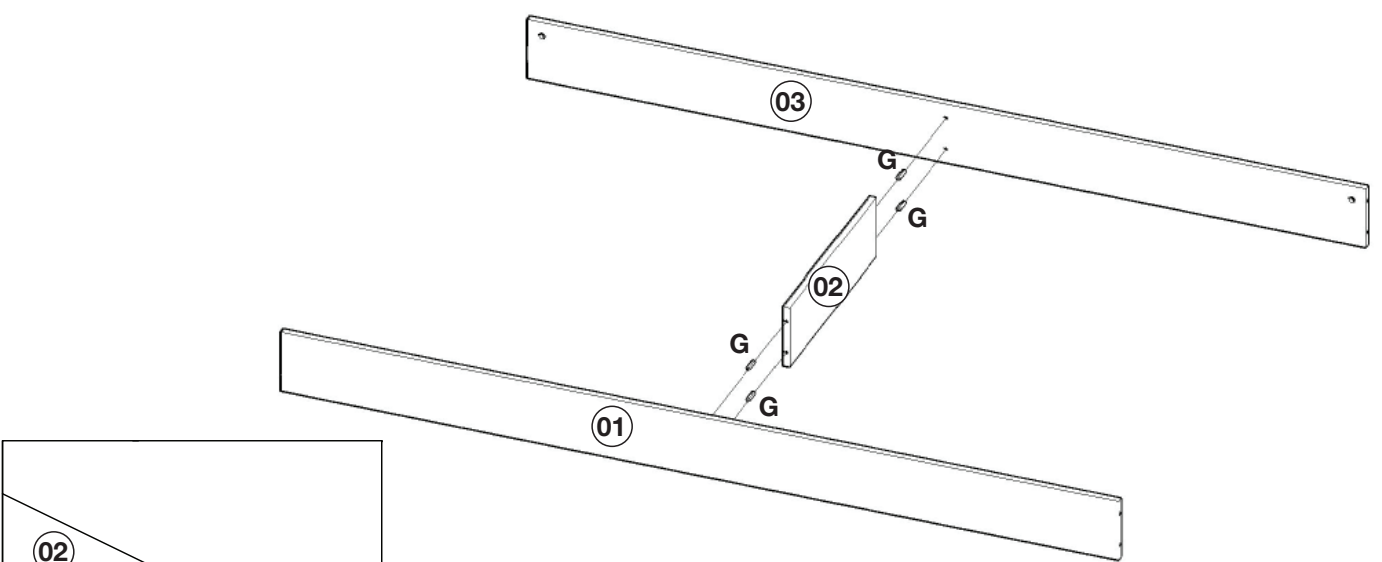

Usar 02 cantoneira (K) para fixação da Base (04).

Utilice 02 soporte (K) para la fijación del Base (04).

Use 02 angle brackets (K) for fix the Base (04).

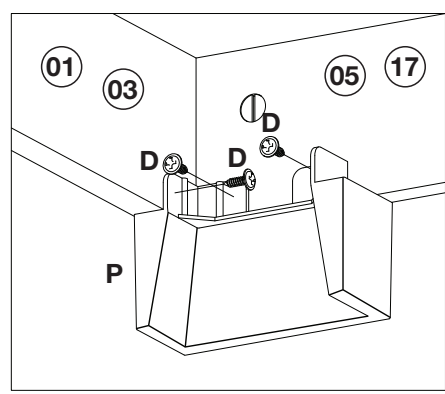
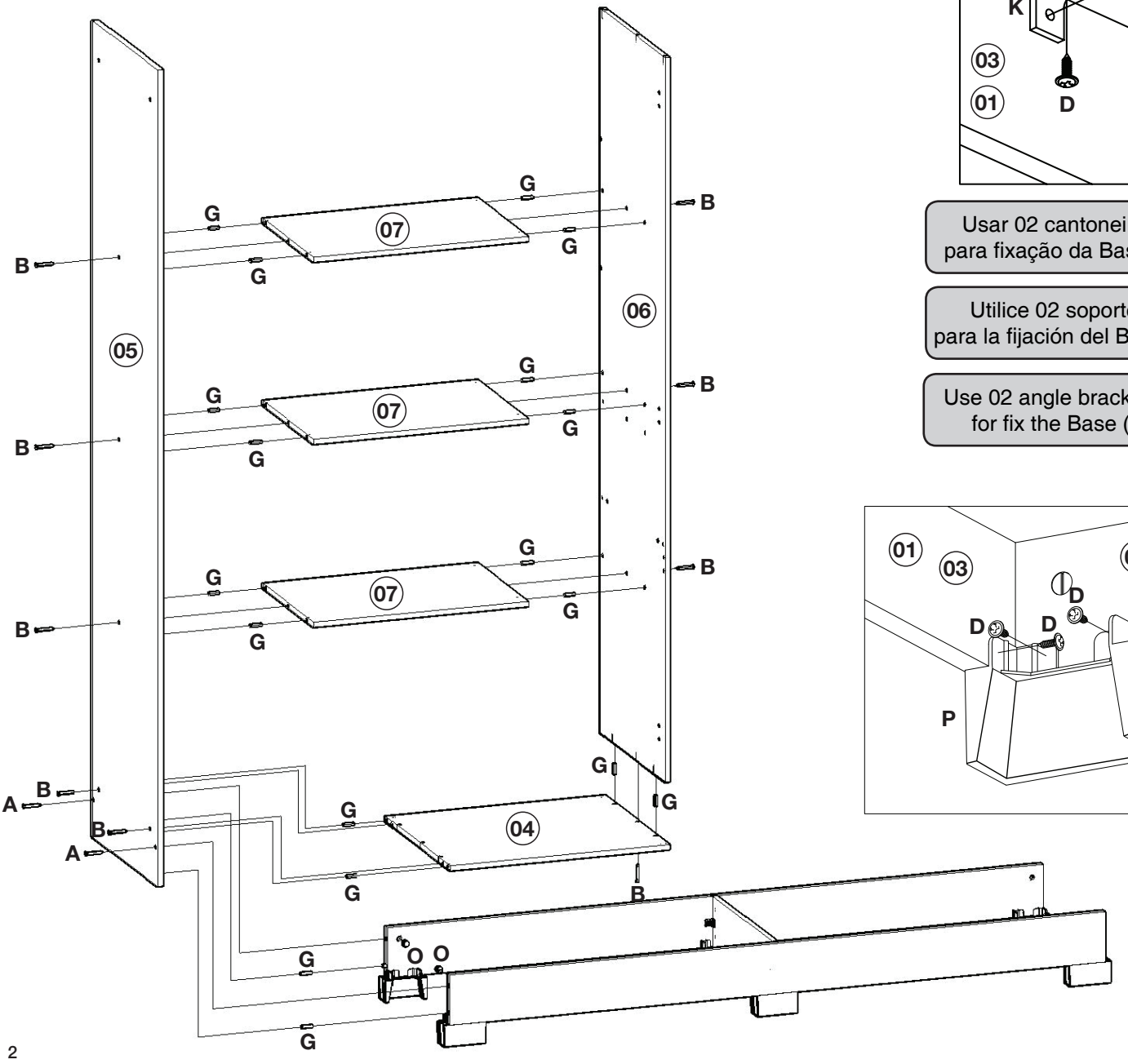

Montagem gaveta 03x.

Montaje de cajón 03x.

Drawer assembly 03x.

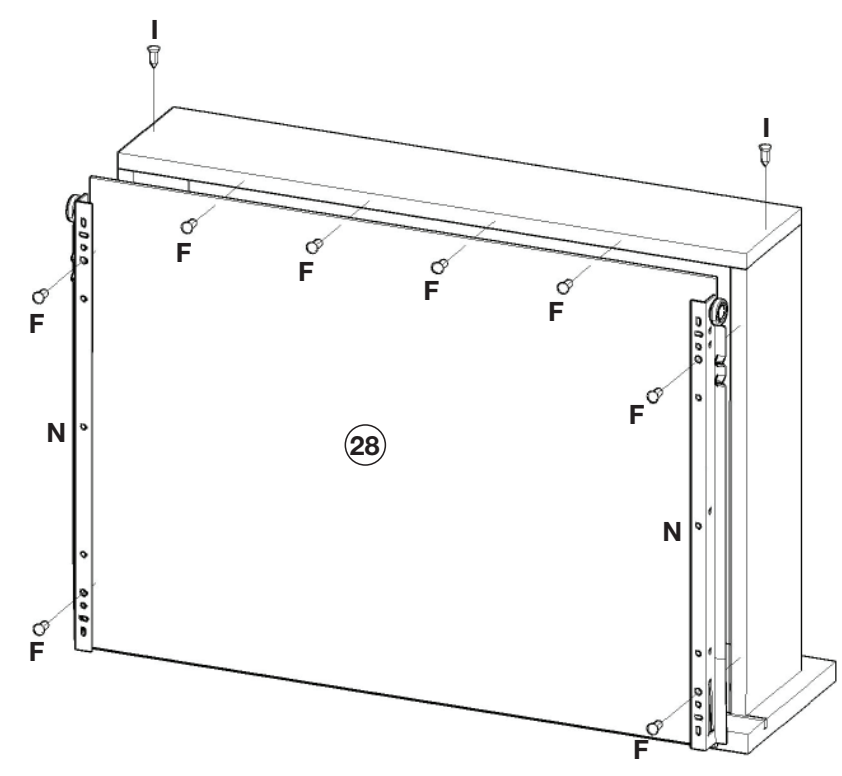
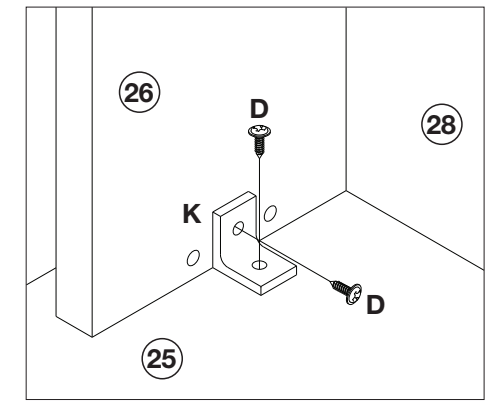
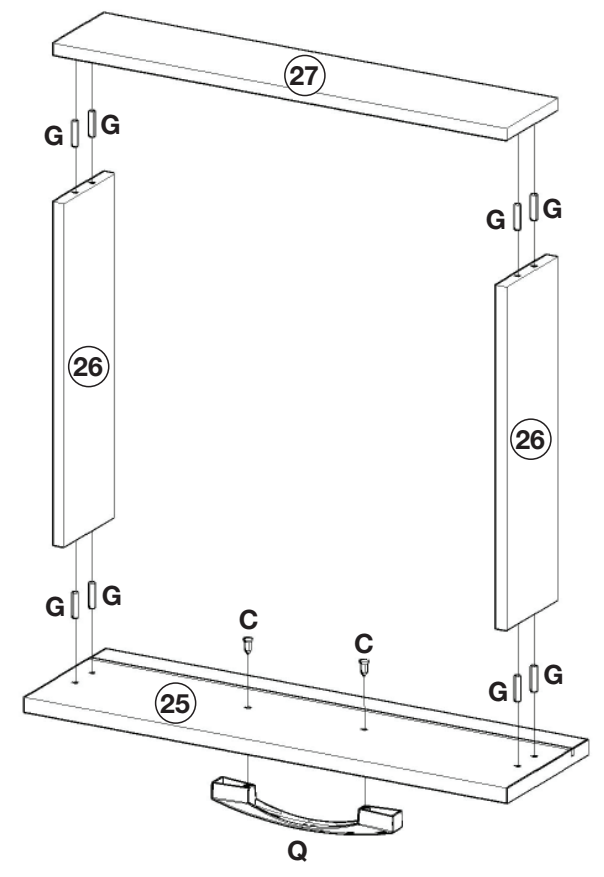

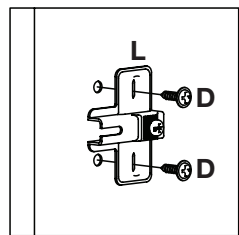

Fixação do calço (L)

Fijación del cunã (L)

Shim fixing (L)

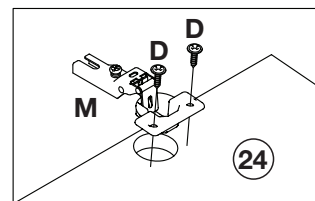

Fixação da dobradiça (M) nas portas (24).

Fijación del bisagra (M) en puertas (24).

Hinge (M) fixing on the doors (24).

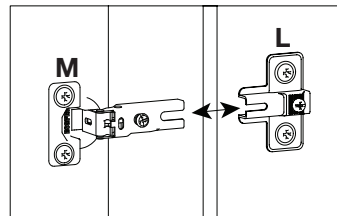

Encaixe da dobradiça (M) com os calços (L).

Fije la bisagra (M) con cunã (L).

Hinge (M) fitting with the shims (L).

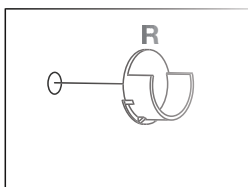

Colocação do suporte cabideiro (R).

La colocación del bastidor de soporte (R).

Fitting the rack stand (R)

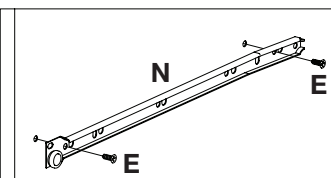
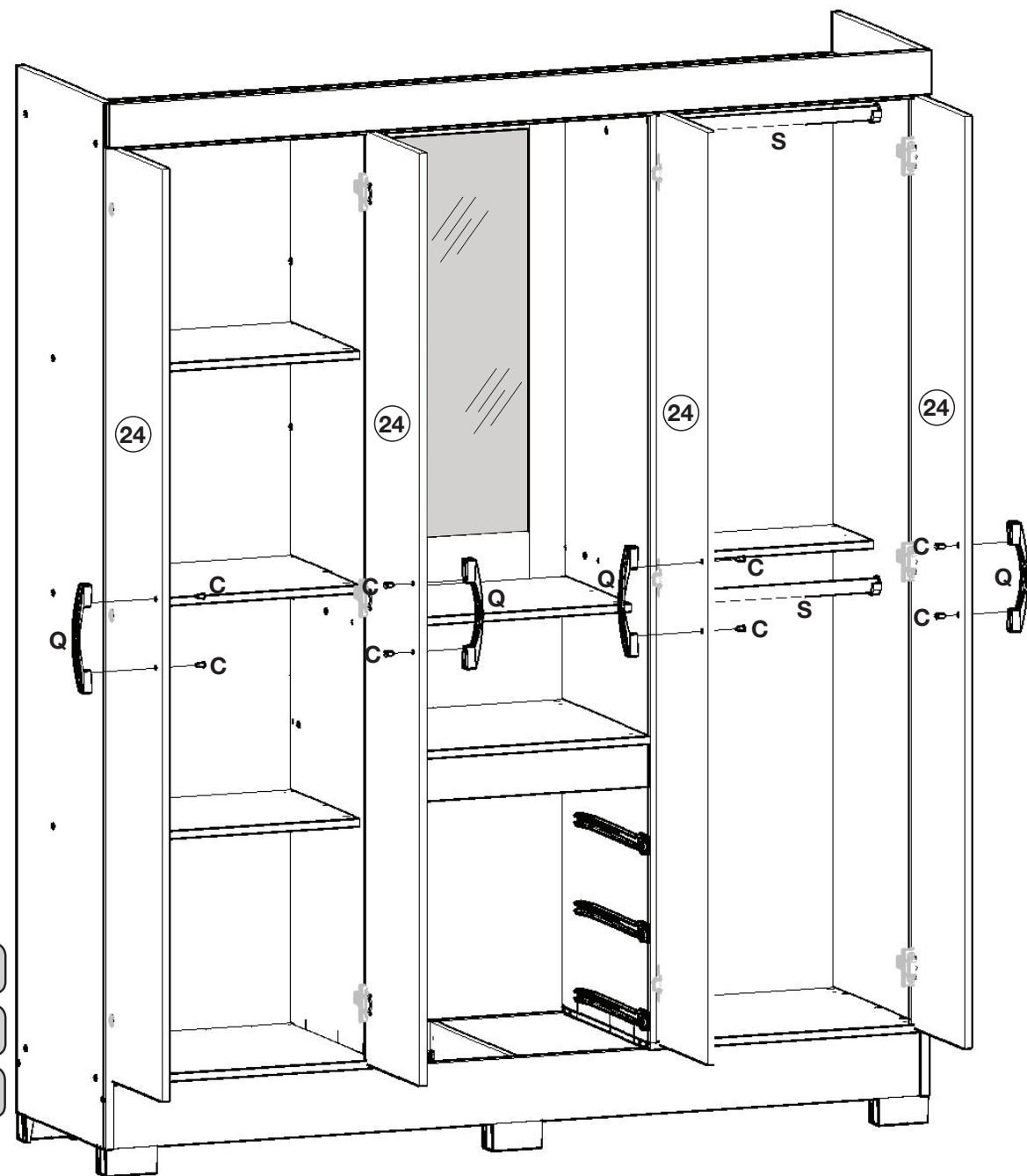

Fixação das corredeiras (N).

La fijación de dispositivos (N).

Slides (N) fixing.

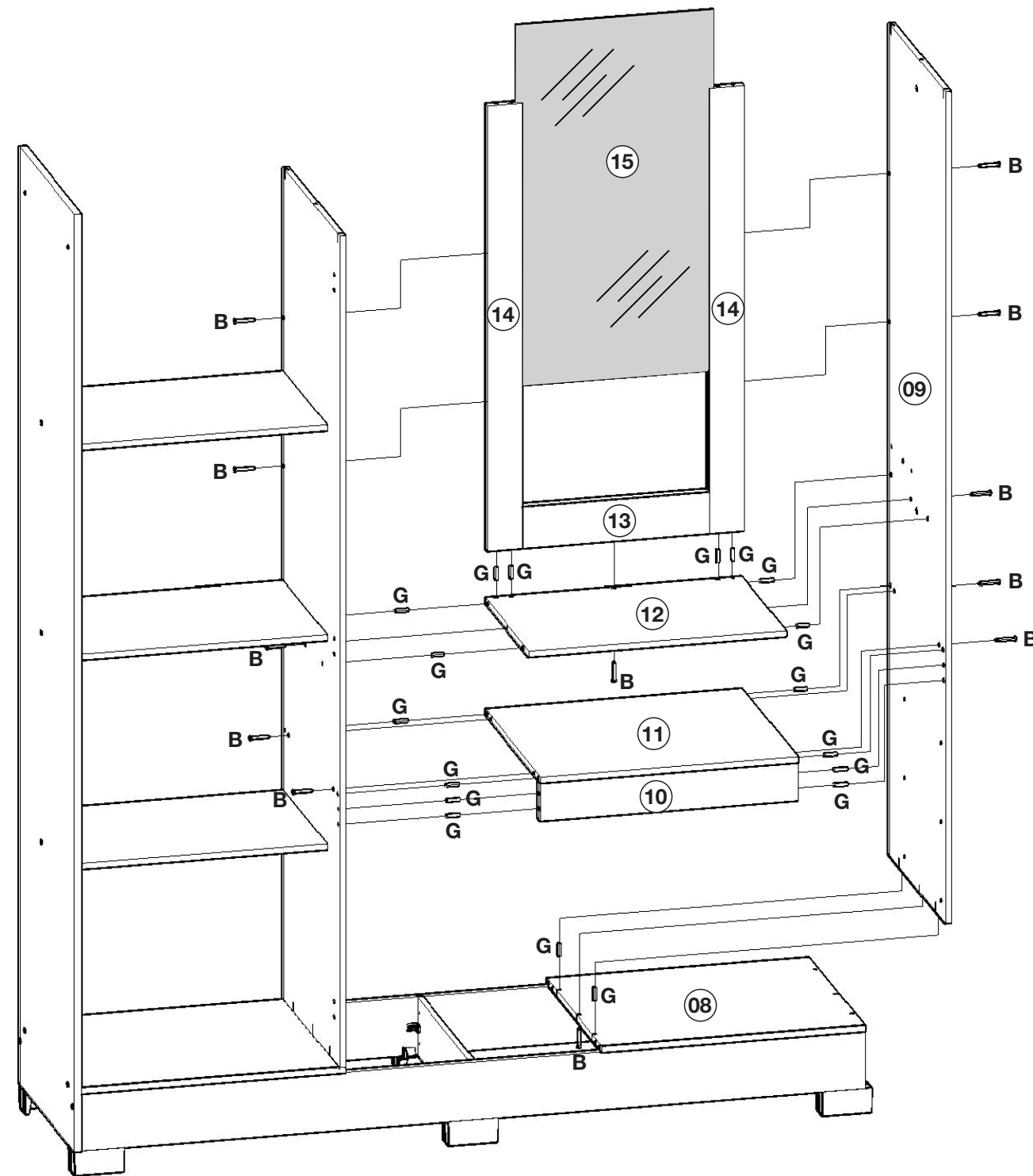
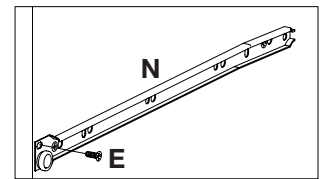

Fixação da Moldura frontal (10).

La fijación del cornija frontal (10).

Front frame (10) fixing.

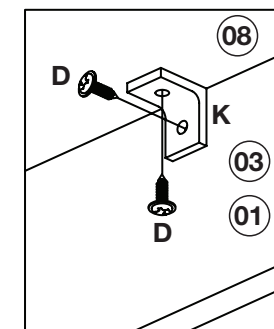
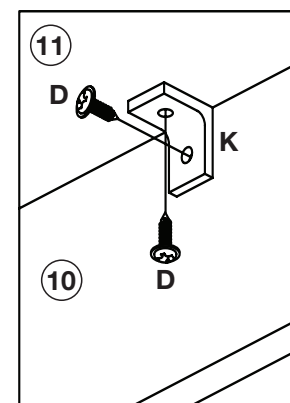

Usar 02 cantoneira (K) para fixação da Base (08).

Utilice 02 soporte (K) para la fijación del Base (08).

Use 02 angle brackets (K) to fix the Base (08).

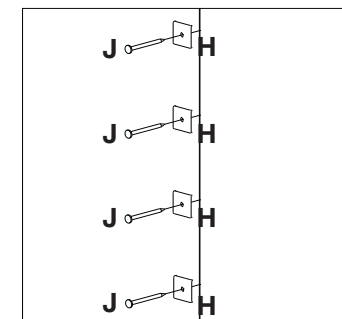
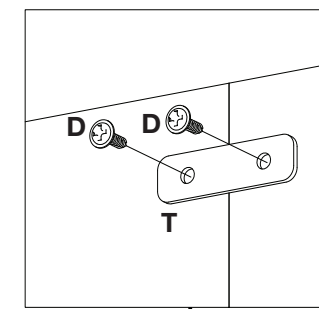
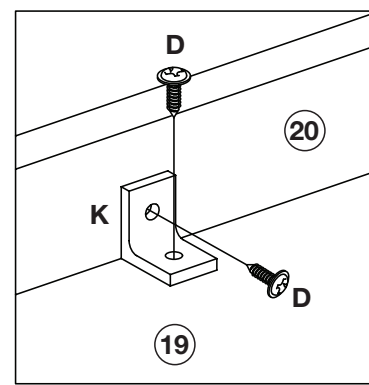
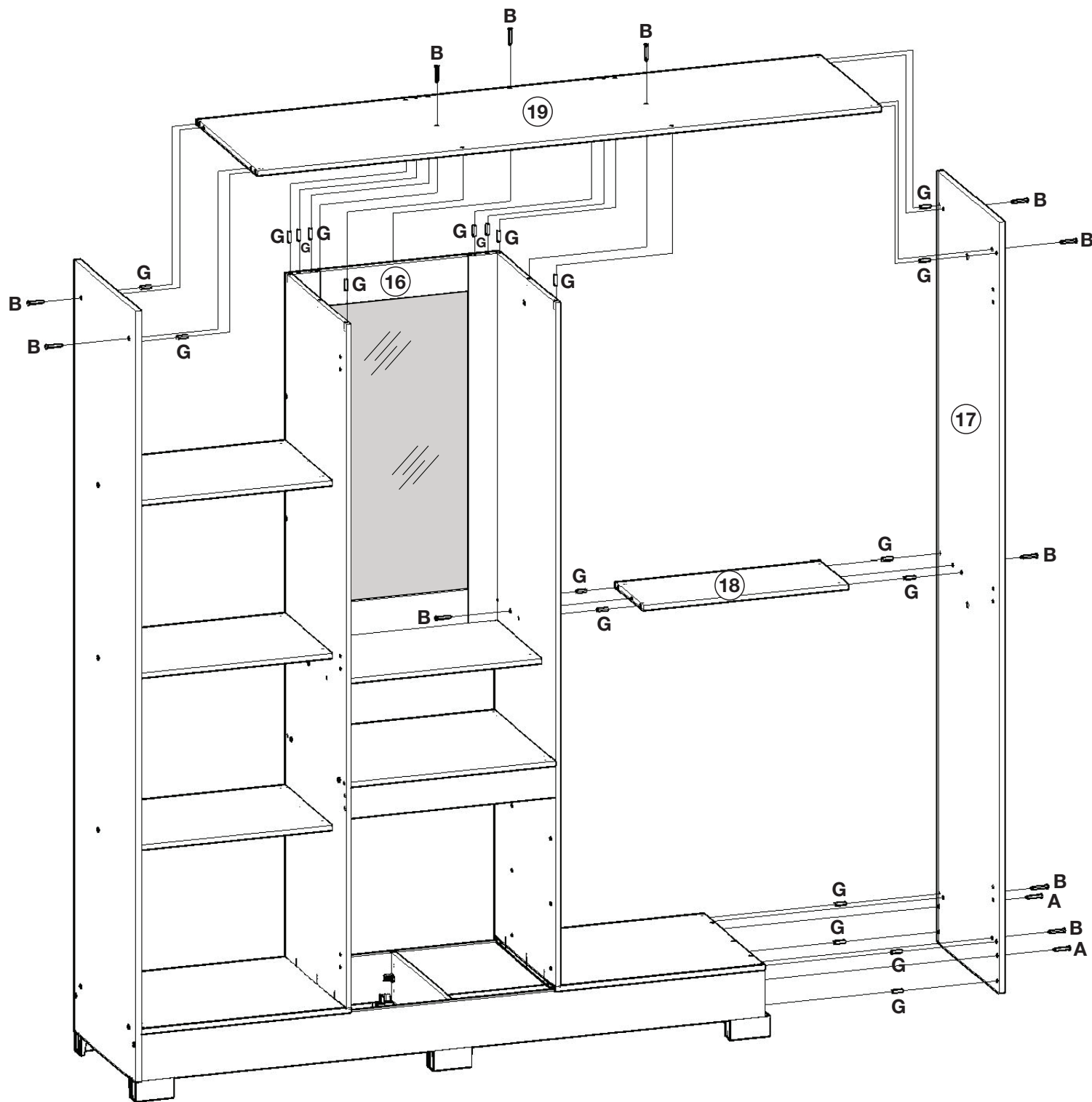

- Fixar os pregos a uma distância de 120mm de um para outro.
- Fijar las uñas a un distancia de 120 mm uno a otro.
- Fix the nails at a distance of 120mm from one to the other

