

# INSTRUÇÕES DE MONTAGEM

## INSTRUCCIONES DE MONTAJE ASSEMBLY INSTRUCTIONS

Roupeiro Fiora 06 Portas / Armario Fiora de 06 Puertas / Fiora 06 Door Wardrobe

- BE134-66 Branco/Branco/Rosa-Chá
- BE134-127 Nature/Off White

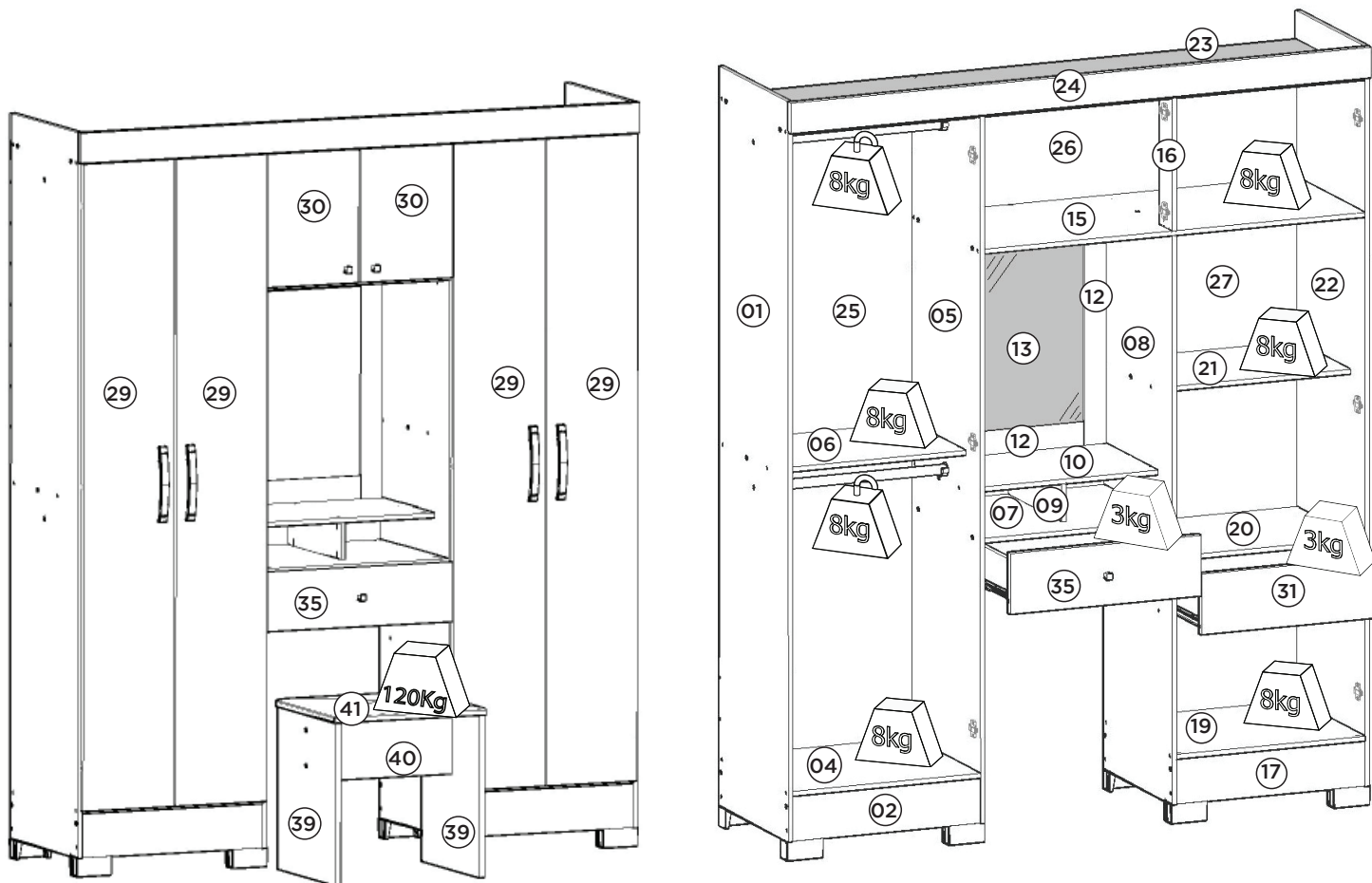

**Pesos máximos recomendados com carga distribuída**  
**Peso máximo recomendado con la carga distribuida**  
**Recommended maximum weights with evenly distributed.**

Requisitos para montagem  
 Requisitor para la montaje  
 Assembly Requirements

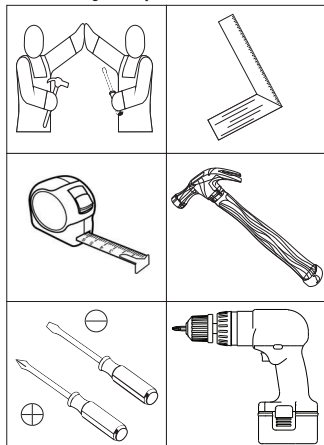

Imagens meramente ilustrativas  
 Imágenes meramente ilustrativas  
 Images for illustration only

### AVISO

Para limpeza de seu móvel, use uma flanela seca ou umedecida, e não utilize produtos químicos que possam danificar seu produto.

### SISTEMA DE MONTAGEM

O sistema de montagem dos produtos, funciona de acordo com a ordem crescente dos números indicados no desenho. Ex: 01, 02, 03, 04... até a conclusão da montagem.

### ADVERTENCIA

Para limpieza de su móvil, use una flanela seca o húmeda, y no utilice productos químicos que puedan dañar su producto.

### SISTEMA DE MONTAJE

El sistema de montaje de los productos funciona de acuerdo con el orden creciente de los números indicados en el dibujo. Ej.: 01, 02, 03, 04... hasta la conclusión del montaje.

### NOTICE

To clean your furniture, use a dry or wet cloth, and do not use chemicals that may damage your product.

### ASSEMBLY SYSTEM

The products' assembly system works according to the increasing order of the indicated numbers. For example: 01, 02, 03, 04 ... to the end of the assembly.

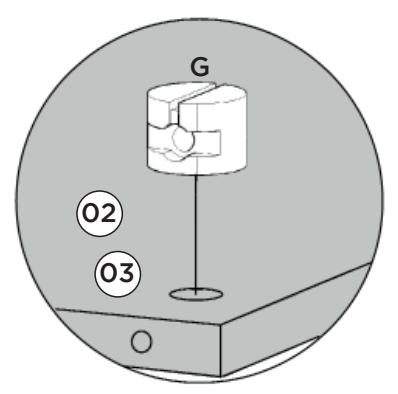
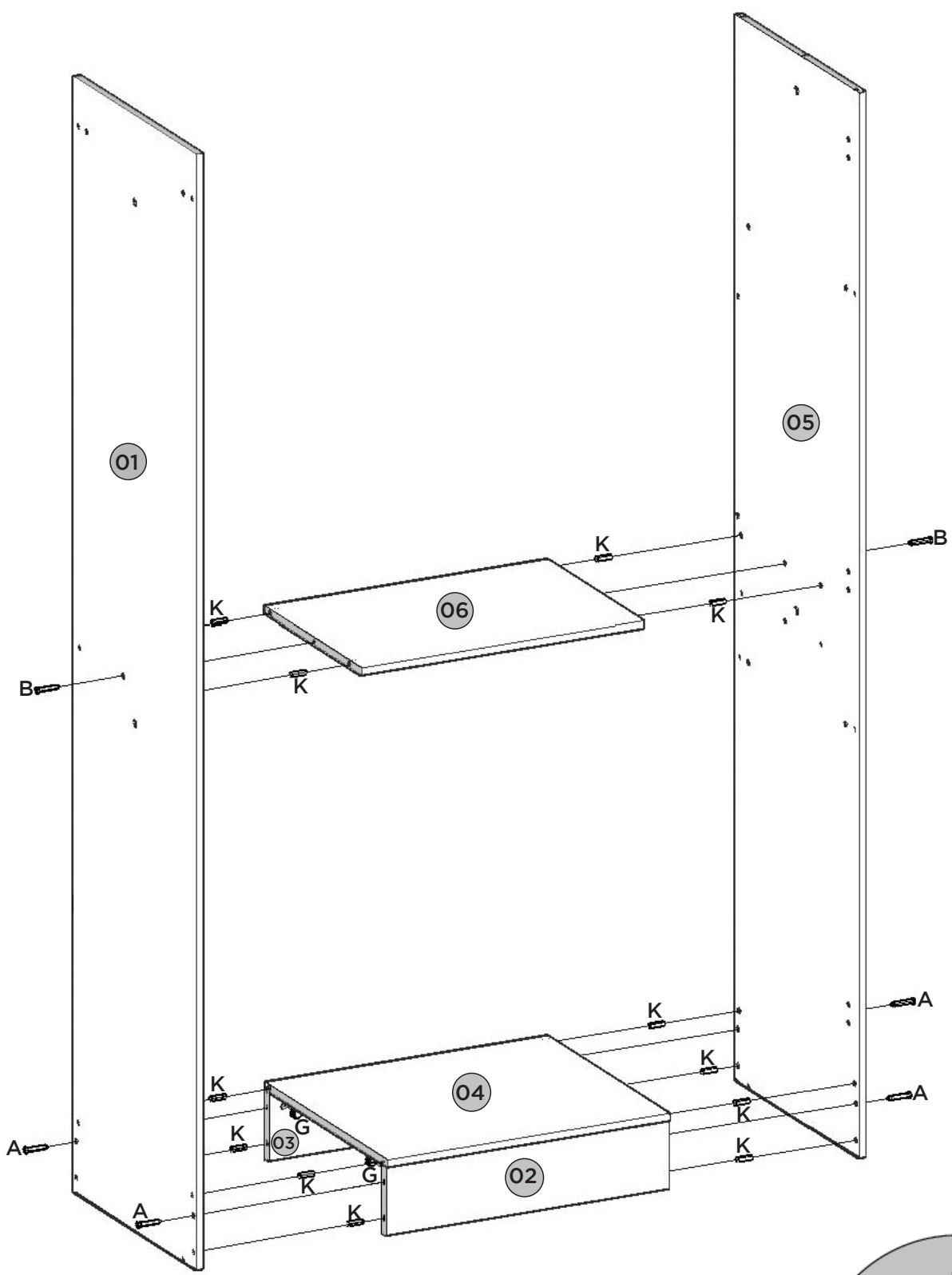

2

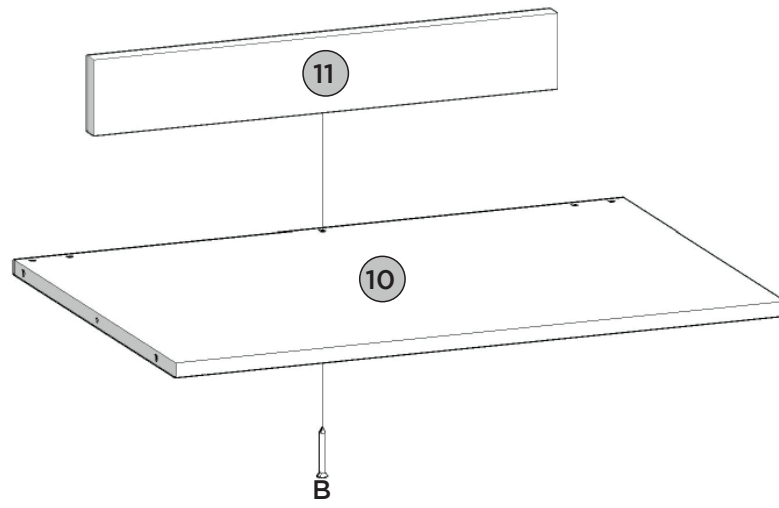

3

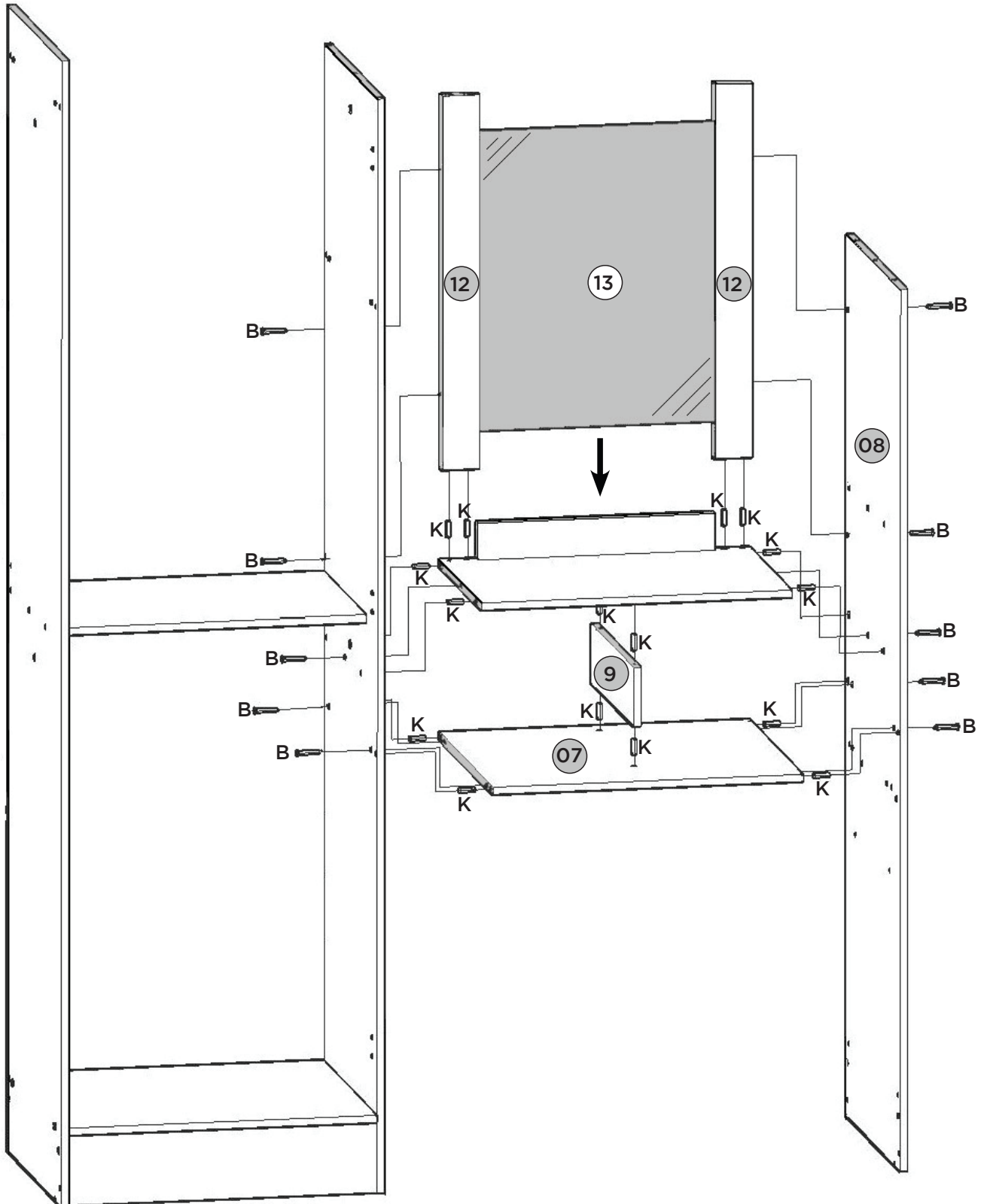

4

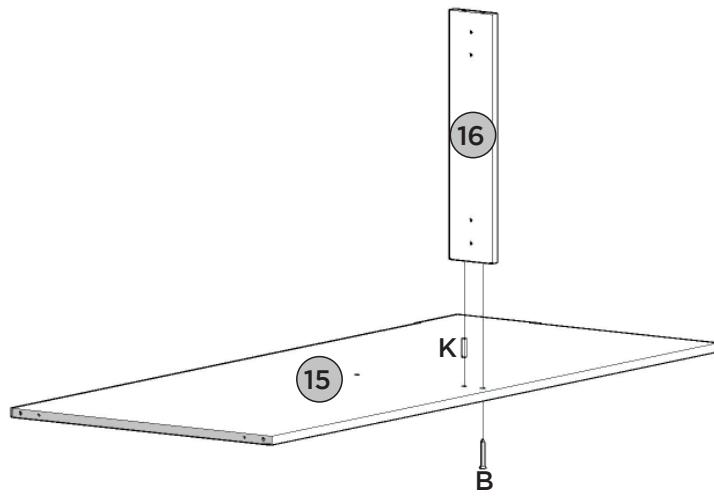

5

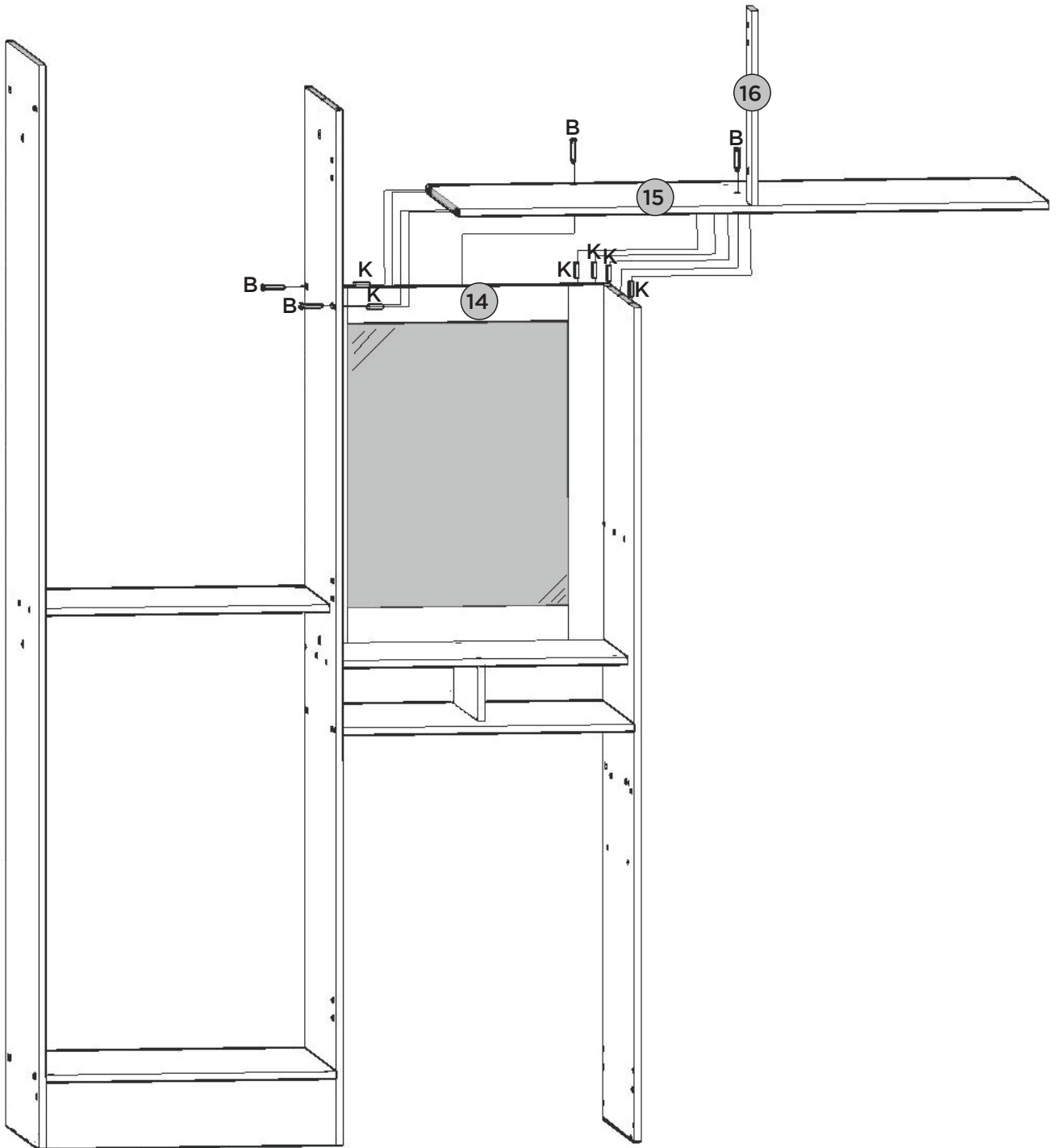

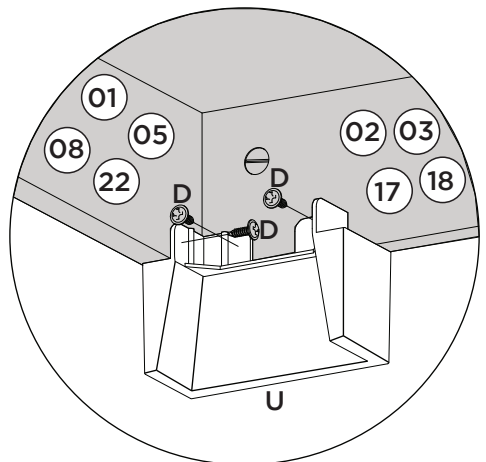
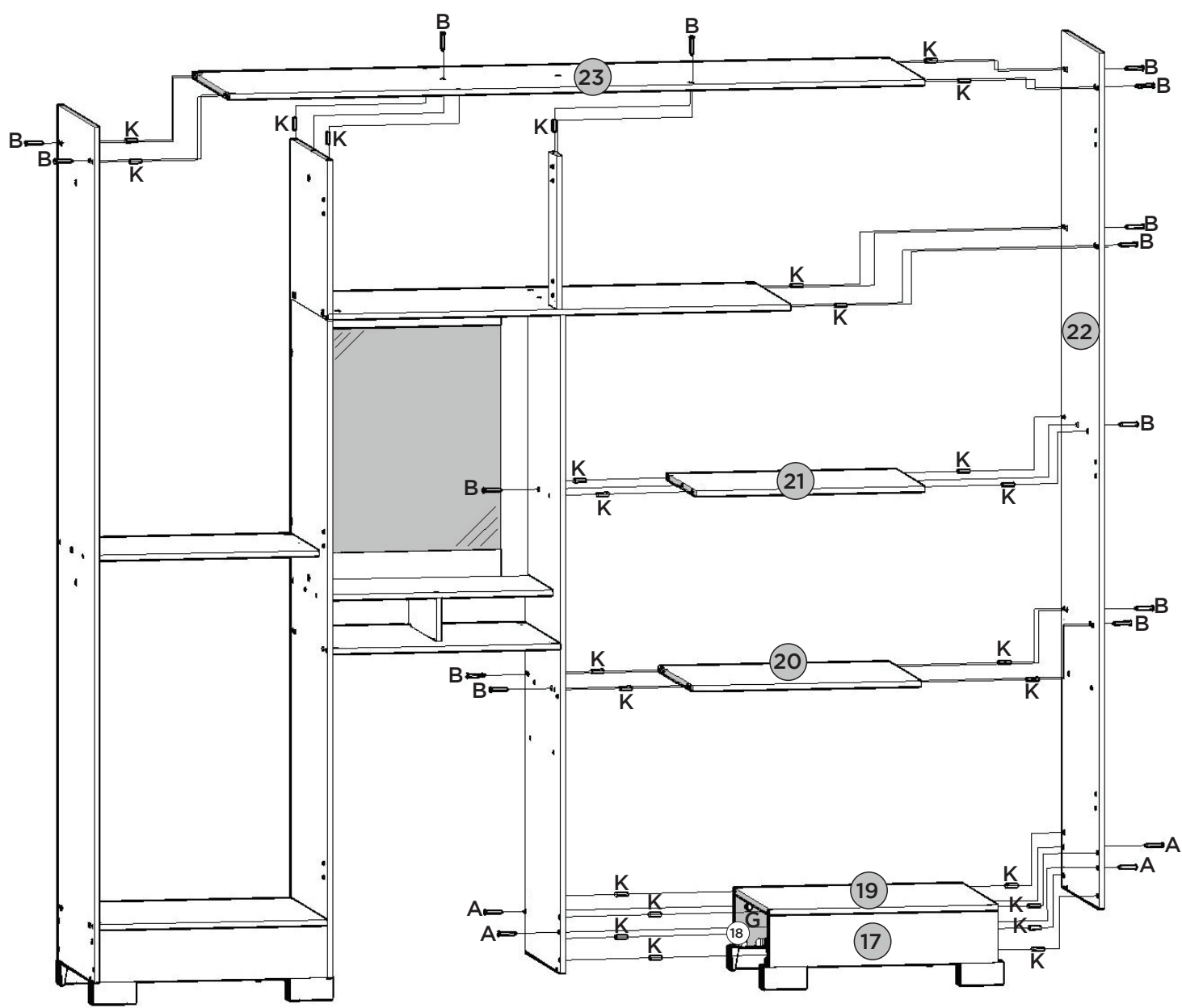

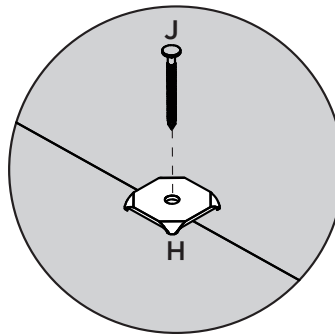
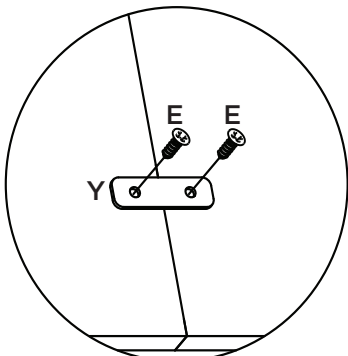
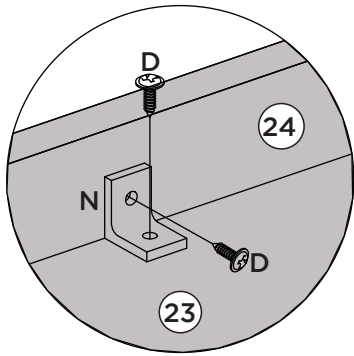

Fixar os pregos a uma distância de 120mm de um para outro.

Fijar las uñas a un distancia de 120 mm uno a otro.

Fix the nails at a distance of 120mm from one to the other

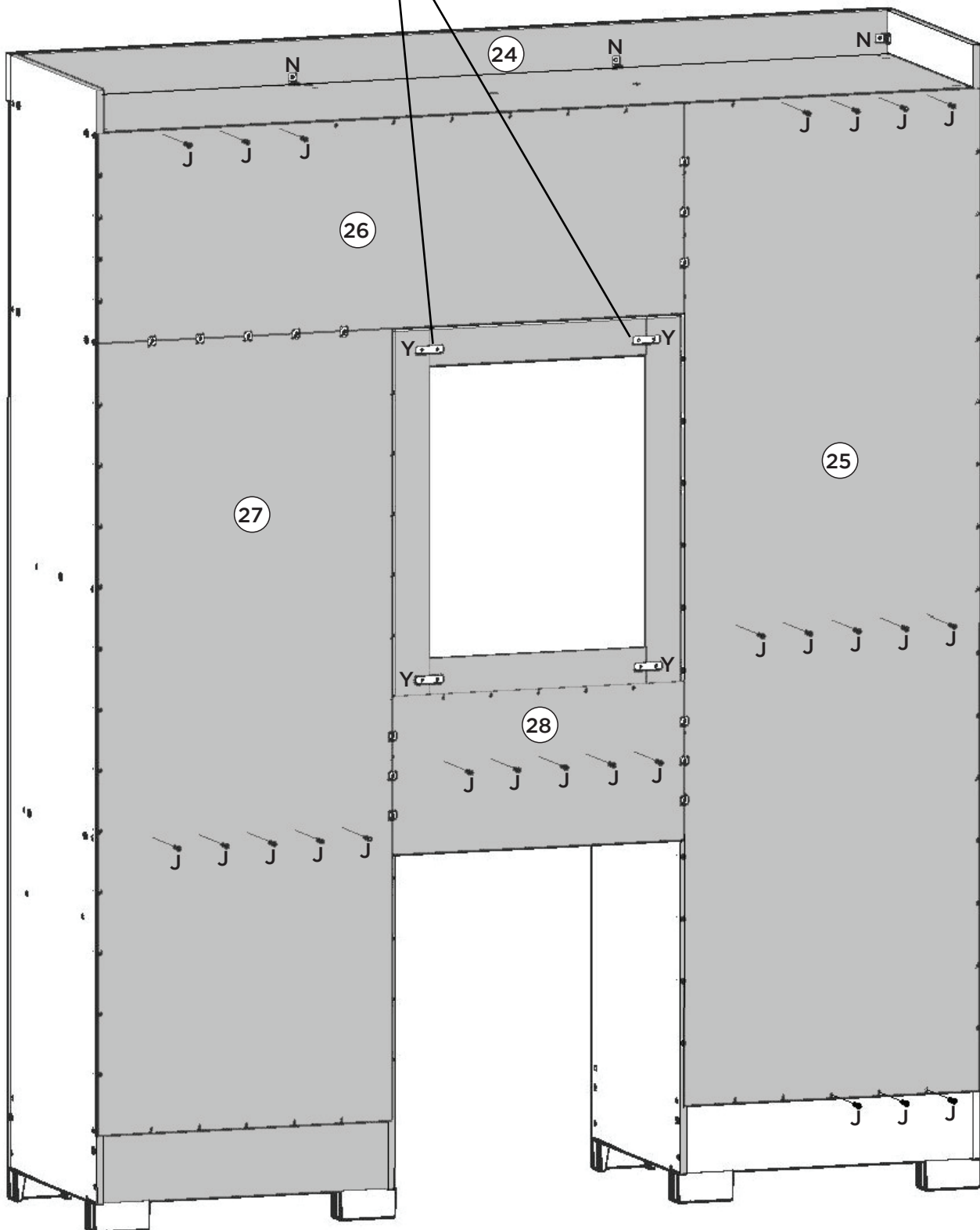

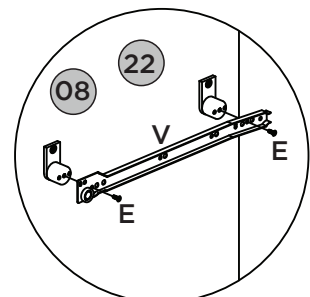
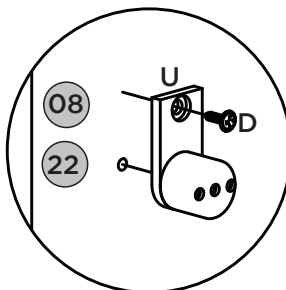
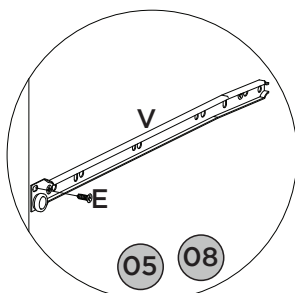
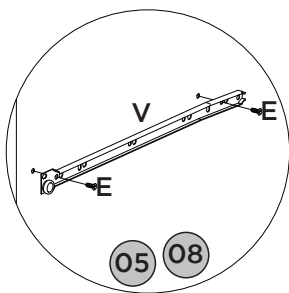
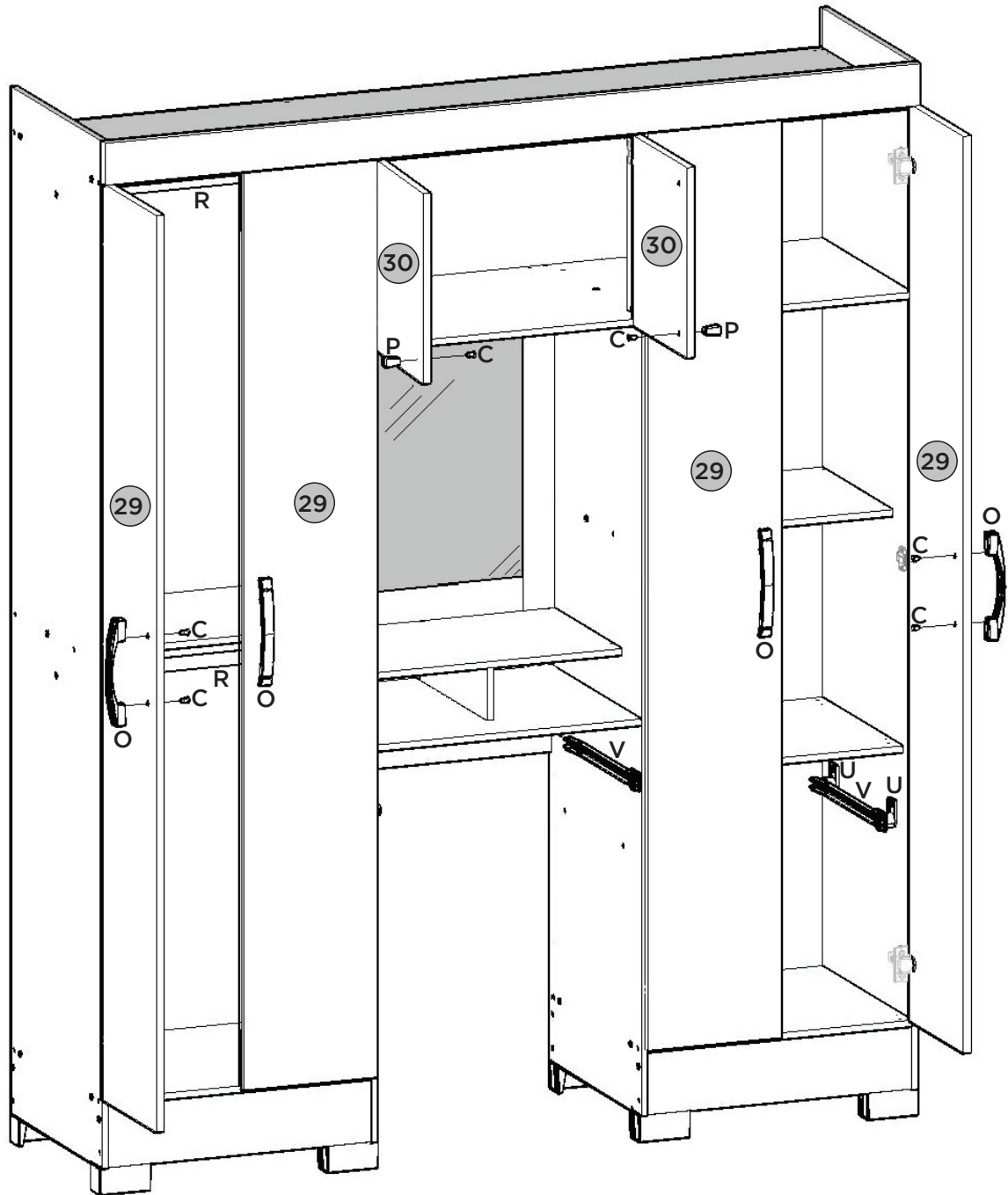
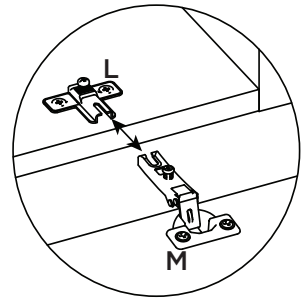
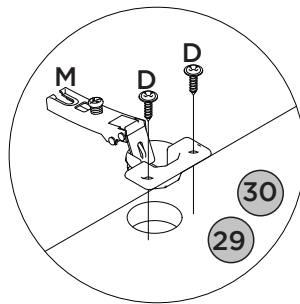
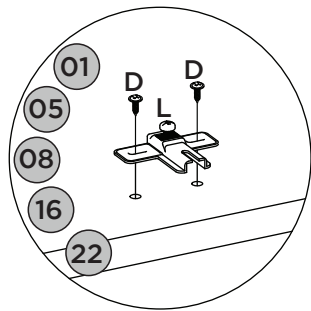
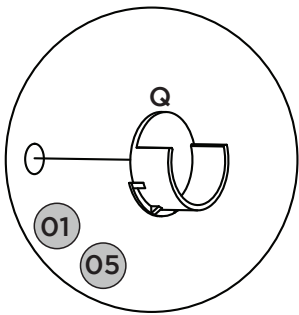

Gaveta interna

Cajón interno

Internal drawer

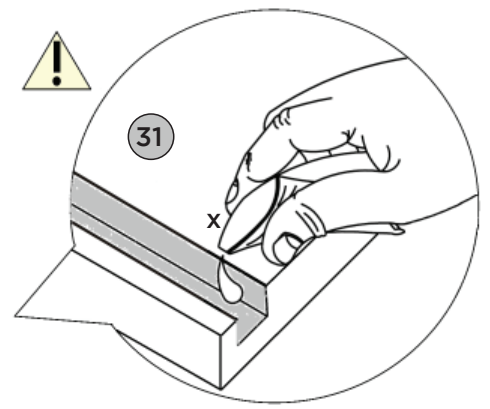
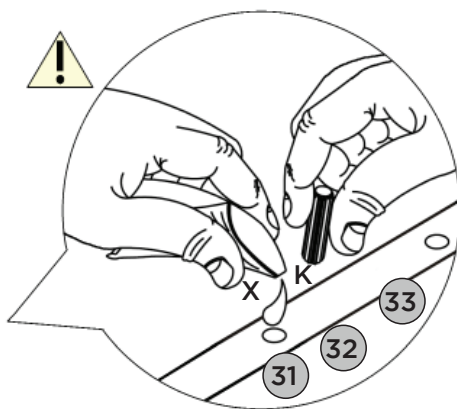
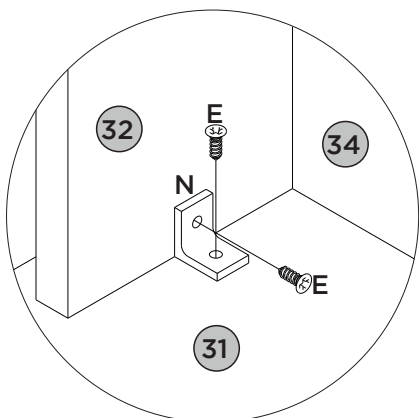
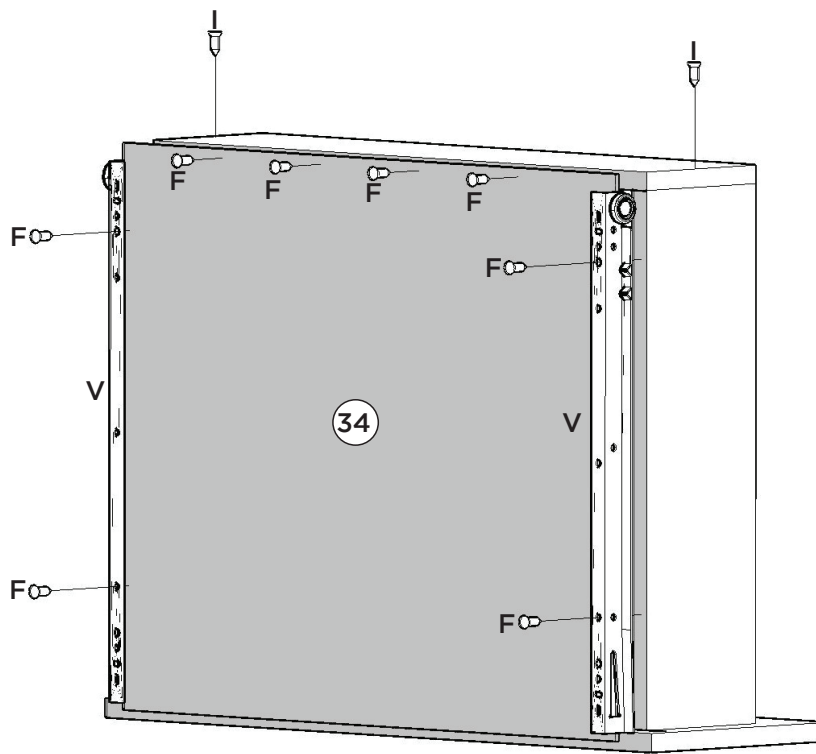
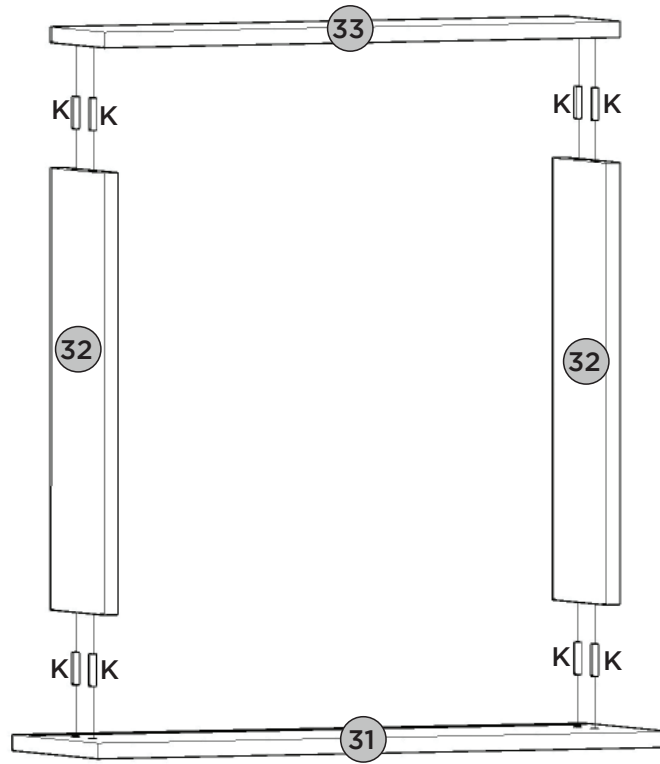



10

Gaveta externa





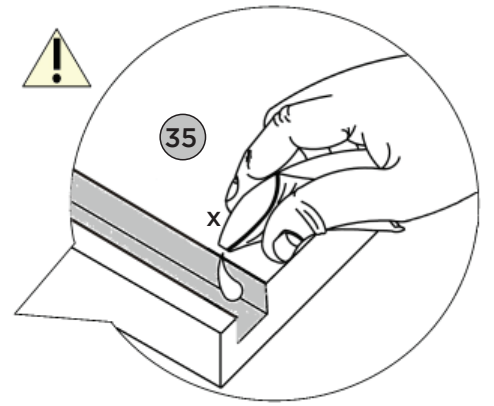
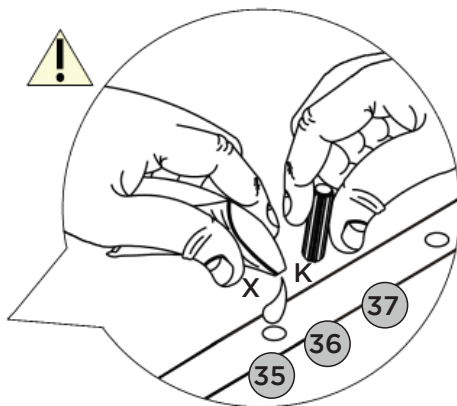
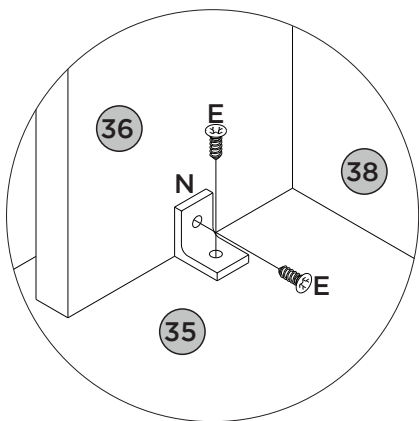
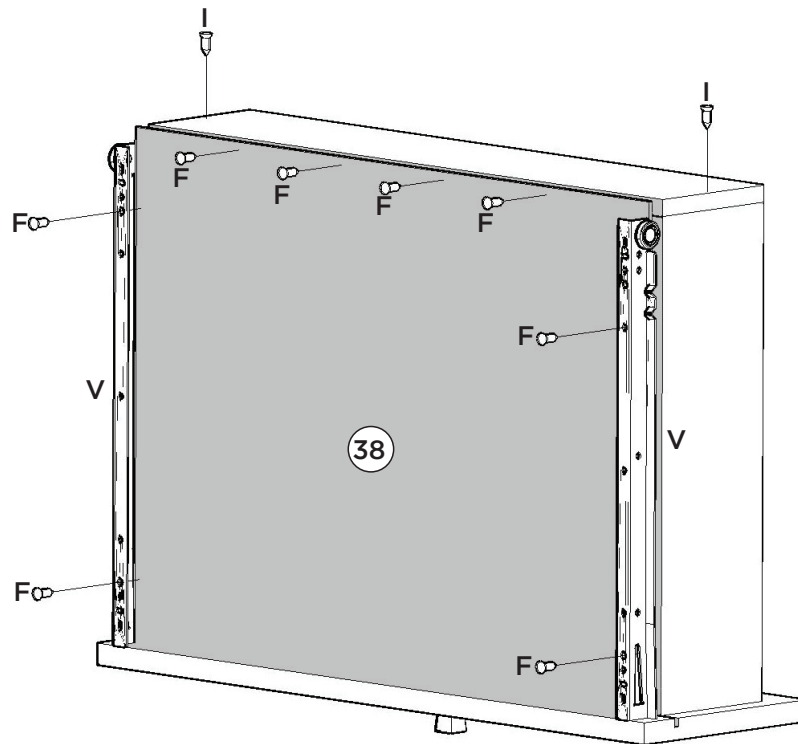
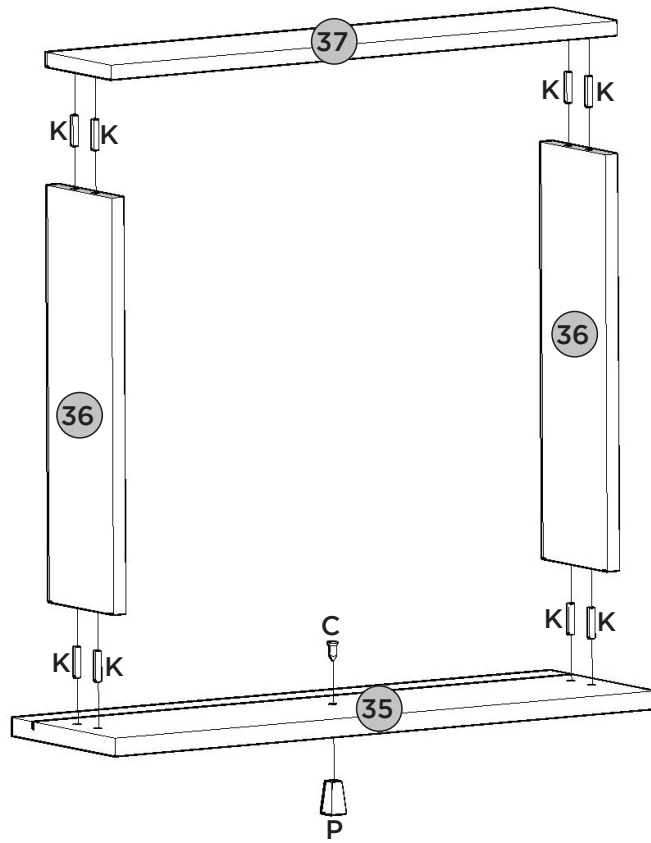

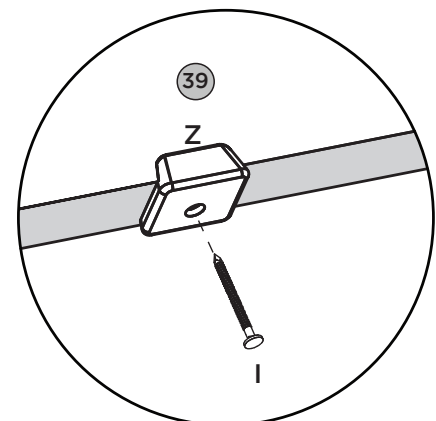
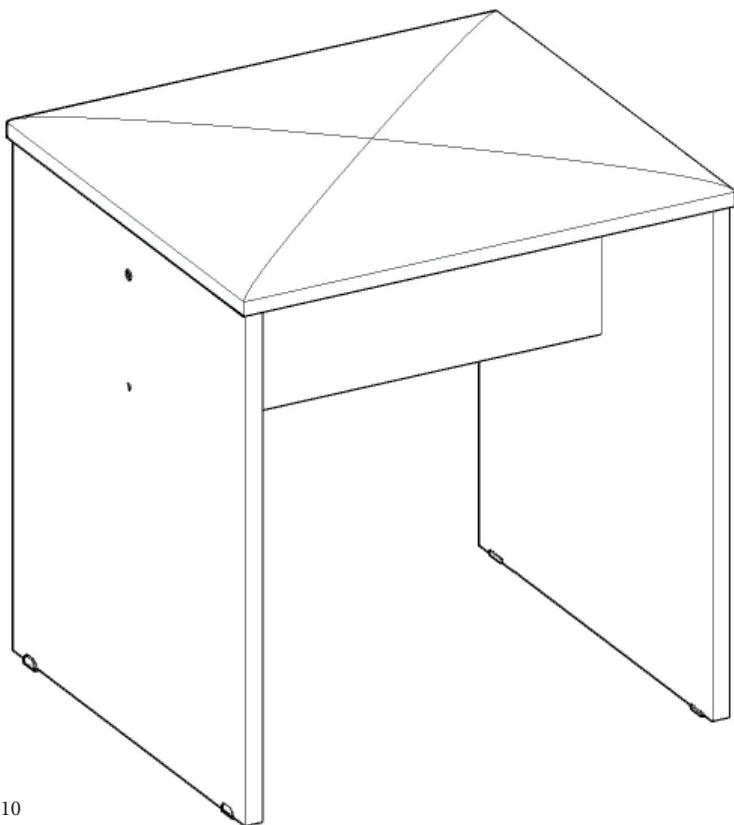
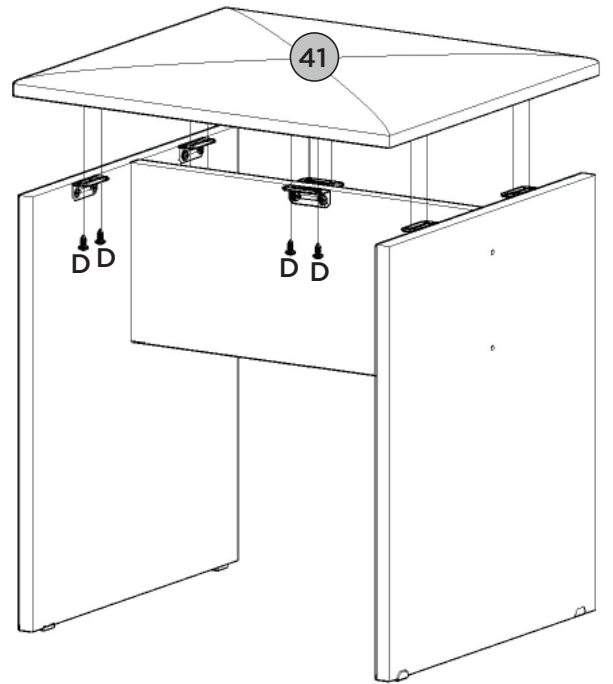
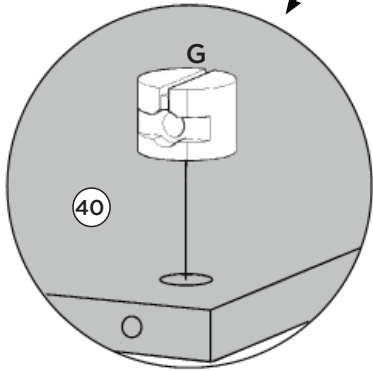
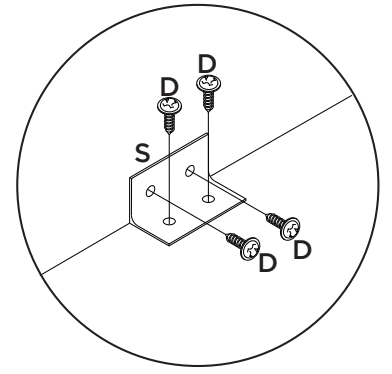
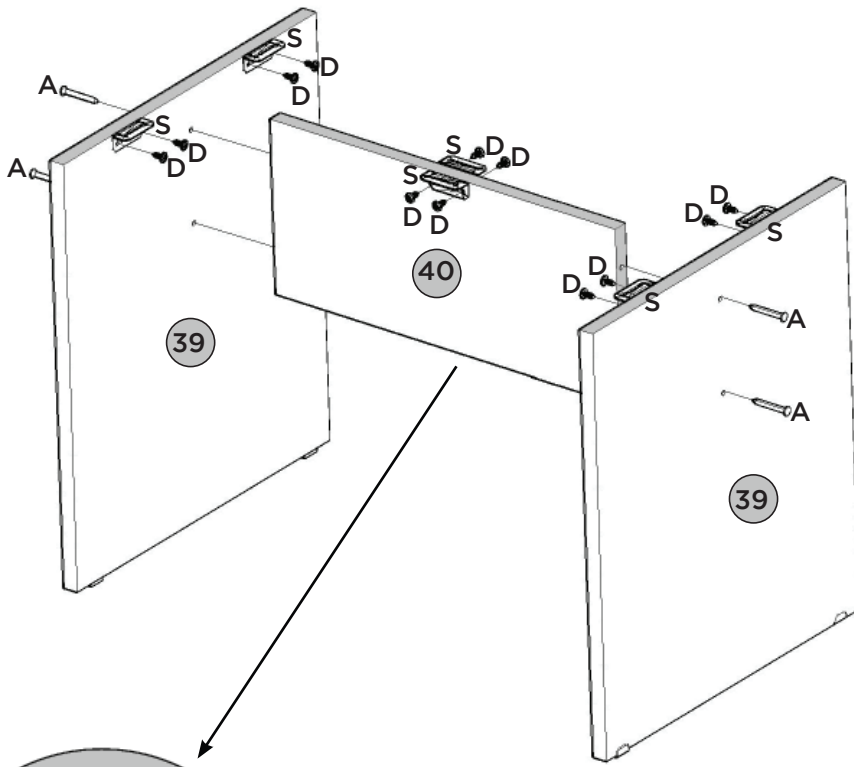





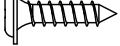
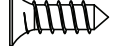

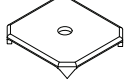

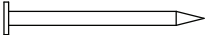

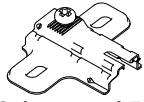
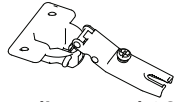

Cajón externo

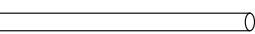
External drawer

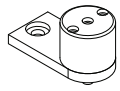

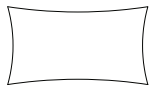

FERRAGENS | HERRAJES | HARDWARE

|  |  |  |   |  |
|--|--|--|---|--|
| <p><b>A</b> 12x</p>  <p>Parafuso 4,5x50mm CHT.<br/>Tornillo 4,5x50mm CHT.<br/>Screw 4,5x50mm CHT.</p>        | <p><b>B</b> 32x</p>  <p>Parafuso 3,5x40mm CHT.<br/>Tornillo 3,5x40mm CHT.<br/>Screw 3,5x40mm CHT.</p> | <p><b>C</b> 11x</p>  <p>Parafuso 3,5x25mm FLA.<br/>Tornillo 3,5x25mm FLA.<br/>Screw 3,5x25mm FLA.</p> | <p><b>D</b> 124x</p>  <p>Parafuso 3,5x12mm FLA.<br/>Tornillo 3,5x12mm FLA.<br/>Screw 3,5x12mm FLA.</p> | <p><b>E</b> 26x</p>  <p>Parafuso 3,5x12mm CHT.<br/>Tornillo 3,5x12mm CHT.<br/>Screw 3,5x12mm CHT.</p>                   |
| <p><b>F</b> 16x</p>  <p>Parafuso 3,0x16mm CHT.<br/>Tornillo 3,0x16mm CHT.<br/>Screw 3,0x16mm CHT.</p>       | <p><b>G</b> 12x</p>  <p>Porca cilíndrica<br/>Tuerca cilíndrica<br/>Cylindrical nut</p>                | <p><b>H</b> 14x</p>  <p>Fixador de fundos<br/>Fijador de fondos<br/>Bottom fixer</p>                  | <p><b>I</b> 08x</p>  <p>Prego 12x12mm Anelado<br/>Clavo 12x12mm Anillado<br/>Ringed Nails 12x12mm</p>   | <p><b>J</b> 106x</p>  <p>Prego 10x10mm<br/>Clavo 10x10mm<br/>Nail 10x10mm</p>   |
| <p><b>K</b> 76x</p>  <p>Cavilha 5x25mm<br/>Cinta 5x25mm<br/>Dowel 5x25mm</p>                                | <p><b>L</b> 16x</p>  <p>Calço metal 5mm<br/>Calzado metálico 5mm<br/>5 mm metal shim</p>              | <p><b>M</b> 16x</p>  <p>Dobradiça metal 26mm<br/>Bisagra de metal 26mm<br/>26 mm metal hinge</p>      | <p><b>N</b> 08x</p>  <p>Cantoneira plástica<br/>Cantonera plástica<br/>Plastic angle brackets</p>      | <p><b>O</b> 04x</p>  <p>Puxador Indonésia 128mm<br/>Tirador Indonésia 128mm<br/>128mm Indonésia Handle</p>              |
| <p><b>P</b> 03x</p>  <p>Puxador Pontual Kannan<br/>Tirador de Punto Kannan<br/>Kannan Point Knob</p>        | <p><b>Q</b> 04x</p>  <p>Suporte cabideiro<br/>Soporte de percha<br/>Coat hanger support</p>           | <p><b>R</b> 02x</p>  <p>Cabideiro Madeira 519mm<br/>Cabezal Madera 519mm<br/>519mm wooden hanger</p>  | <p><b>S</b> 06x</p>  <p>Cantoneira 17,5x17,5x44<br/>Cantonera 17,5x17,5x44<br/>Angle 17,5x17,5x44</p>  | <p><b>T</b> 24x</p>  <p>Adesivo tapa parafuso 10mm<br/>Adhesivo tapón de tornillo 10mm<br/>Bolt cover adhesive 10mm</p> |
| <p><b>U</b> 04x</p>  <p>Distanciador de corredeira<br/>Distanciador de deslizamiento<br/>Sliding spacer</p> | <p><b>V</b> 02x</p>  <p>Corredeira metal 350mm<br/>Corredera metal 350mm<br/>Sliding metal 350mm</p>  | <p><b>W</b> 01x</p>  <p>Etiqueta resinada Briz<br/>Etiqueta resinada Briz<br/>Briz resin label</p>    | <p><b>X</b> 02x</p>  <p>Sachê de cola<br/>Bolsa de pegamento<br/>Glue bag</p>                          | <p><b>Y</b> 04x</p>  <p>Suporte de metal<br/>Soporte de metal<br/>Metal stands</p>                                      |
| <p><b>Z</b> 04x</p>  <p>Sapata "L" 16x20<br/>Zapata "L" 16x20mm<br/>Shoe "L" 16x20mm</p>                  | <p><b>AA</b> 08x</p>  <p>Pé "U" 50x40x100mm<br/>Pie "U" 50x40x100mm<br/>50x40x100mm "U" feet</p>    |  |   |  |

LISTA DE PEÇAS | LISTA DE PIEZAS | PARTS LIST

| Item  | Caixa<br>Caja<br>Box | Qtd<br>Ctd<br>Qty | Descrição  <br>Descripción  <br>Description   | Medidas (mm)  <br>Dimensions (mm)  <br>Size (measurements)<br>(mm) |
|-------|----------------------|-------------------|---|--|
| 01    | 1/2                  | 01                | Lateral esquerda   Lateral izquierda   Left side                                    | 1950x445x12  |
| 02=17 | 2/2                  | 01                | Rodapé frontal   Rodapié frontal   Front footboards                                 | 525x120x12   |
| 03=18 | 2/2                  | 01                | Rodapé traseiro   Rodapié trasero   Rear footboard                                  | 525x120x12   |
| 04=19 | 1/2                  | 01                | Base   Base   Base  | 525x445x12   |
| 05    | 1/2                  | 01                | Divisão esquerda   División izquierda   Left division                               | 1862x445x12  |
| 06=21 | 1/2                  | 02                | Prateleira   Estante   shelf  | 525x350x12   |
| 07    | 2/2                  | 01                | Base Central   Base Central   Central Base  | 525x445x12   |
| 08    | 2/2                  | 01                | Divisão direita   División derecha   Right division                                 | 1500x445x12  |
| 09    | 1/2                  | 01                | Divisão Nicho   División de Nicho   Niche Division                                  | 350x100x12   |
| 10    | 2/2                  | 01                | Tampo Nicho   Tampo Nicho   Niche Top   | 525x350x12   |
| 11=14 | 1/2                  | 02                | Moldura Inferior Superior   Cornija Inferior Superior   Top Bottom Frame            | 399x63x15  |
| 12    | 1/2                  | 02                | Moldura Lateral   Cornija Lateral   Side Frame                                      | 637x63x15  |
| 13    | 2/2                  | 01                | Espelho   Espejo   Mirror   | 510x88x15  |
| 14=11 | 1/2                  | 02                | Moldura Inferior Superior   Cornija Inferior Superior   Top Bottom Frame            | 399x63x15  |
| 15    | 1/2                  | 01                | Chão do Maleiro   Piso Maleiro   Maleiro Floor                                      | 1062x445x12  |
| 16    | 1/2                  | 01                | Ripa do Maleiro   Tablilla Maleiro   Tablilla Maleiro                               | 350x73x12  |
| 17=02 | 2/2                  | 01                | Rodapé frontal   Rodapié frontal   Front footboards                                 | 525x120x12   |
| 18=03 | 2/2                  | 01                | Rodapé traseiro   Rodapié trasero   Rear footboard                                  | 525x120x12   |
| 19=04 | 1/2                  | 01                | Base   Base   Base  | 525x445x12   |
| 20    | 1/2                  | 01                | Tampo da Gaveta   Tapa del cajón   Drawer Top                                       | 525x400x12   |
| 21=06 | 1/2                  | 02                | Prateleira   Estante   shelf  | 525x350x12   |
| 22    | 1/2                  | 01                | Lateral direita   Lateral derecha   Right side                                      | 1950x445x12  |
| 23    | 2/2                  | 01                | Tampo   Tapa   Cover  | 1599x445x12  |
| 24    | 2/2                  | 01                | Chapéu   Sombrero   Hat   | 1621x80x15   |
| 25    | 2/2                  | 01                | Fundo Maior   Fondo más grande   Bigger Bottom                                      | 1754x540x3   |
| 26    | 2/2                  | 01                | Fundo Superior   Fondo Superior   Top Bottom  | 1077x367x3   |
| 27    | 2/2                  | 01                | Fundo Lateral   Parte inferior lateral   Side Bottom                                | 1385x540x3   |
| 28    | 2/2                  | 01                | Fundo Nicho   Fondo de Nicho   Niche Background                                     | 535x277x3  |
| 29    | 2/2                  | 04                | Porta   Puerta   Door   | 1738x265x15  |
| 30    | 1/2                  | 02                | Porta Central   Puerta central   Central Door                                       | 358x265x15   |
| 31    | 2/2                  | 01                | Frente de Gaveta   Frente del Cajón   Drawer Front                                  | 485x160x12   |
| 32=36 | 1/2                  | 04                | Lado de gaveta   Lado del cajón   Drawer side                                       | 350x100x12   |
| 33    | 2/2                  | 01                | Ripa de trás   Listón trasero   Rear batten   | 450x100x12   |
| 34    | 2/2                  | 01                | Fundo de Gaveta Recortado   Fondo de cajón recortado  <br>Cropped Drawer Background | 449x367x3  |
| 35    | 2/2                  | 01                | Frente de Gaveta Maior   Frente de Cajón Más Grande                                 | 533x160x15   |
| 36=32 | 1/2                  | 02                | Lado de gaveta   Lado del cajón   Drawer side                                       | 350x100x12   |
| 37    | 2/2                  | 01                | Ripa de Trás Maior   Tablilla Trasera Más Grande   Larger back<br>clapboard         | 500x100x12   |
| 38    | 2/2                  | 01                | Fundo de Gaveta   Fondo de Cajón   Drawer Bottom                                    | 499x367x3  |
| 39    | 1/2                  | 02                | Lateral Menor   Lado Menor   Minor Side   | 438x380x15   |
| 40    | 1/2                  | 01                | Travessa Assento   Bandeja de Asiento   Seat Platter                                | 400x180x15   |
| 41    | 1/2                  | 01                | Assento estofado   Asiento tapizado   Upholstered seat                              | 430x380x42   |