

ASPECTO MONTADO / ASSEMBLY ASPECT /  
 ASPECTO LISTO

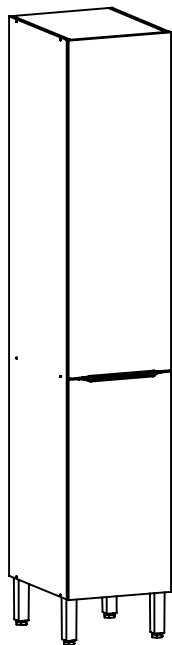

ASPECTO TRASEIRO / BOTTOM ASPECT /  
 ASPECTO TRASERO



LISTA DE PEÇAS / LIST OF PIECE / LISTAJE DE PIEZAS

Nº	CÓD.	NOME DA PEÇA / NAME OF THE PIECE / NOMBRE DE LA PIEZA	MEDIDA	QTDE	MAT. PRIMA
01	111921	ACESSÓRIO DE MONTAGEM / ASSEMBLY ACCESSORY / ACCESORIO DE MONTAJE	-	01	DIVERSOS
02	908640	PÉS / FEET / PATA	170MM	04	PLÁSTICO
03	111922.2020.0500	LATERAL DIREITA / RIGHT LATERAL / LATERAL DERECHA	2020x500x15	01	MDP
04	111923.2020.0500	LATERAL ESQUERDA / LEFT LATERAL / LATERAL IZQUIERDA	2020x500x15	01	MDP
05	111082.0370.0500	CHAPÉU / HAT / CUBIERTA	370x500x15	01	MDP
06	102432.0370.0500	BASE / BASE / BASE	370x500x15	01	MDP
07	111065.0370.0500	PRATELEIRA II / SHELF II / REPISA II	370x500x15	01	MDP
08	111066.0370.0430	PRATELEIRA I / SHELF I / REPISA I	370x430x15	03	MDP
09	112335.1218.0397	PORTA SUPERIOR / UPPER DOOR / PUERTA SUPERIOR	1218x397x15	01	MDP
10	111925.0795.0397	PORTA INFERIOR / LOWER DOOR / PUERTA INFERIOR	795x397x15	01	MDP
11	111084.2015.0395	TRASEIRO / BOTTOM / TRASERO	2015x395x03	01	MADEFIBRA

CÓDIGOS IDENTIFICADOS NO TOPO DA MAIORIA DAS PEÇAS DO PRODUTO.  
 THESE CODES ARE IDENTIFIED ON THE SIDE OF MOST PARTS OF THE PRODUCT.  
 CÓDIGO IMPRESO EN EL CANTO CRUDO DE LA MAYORIA DE LAS PIEZAS.

**ATENÇÃO / ATTENTION / ATENCIÓN:**

- A LIMPEZA DO MÓVEL DEVE SER EFETUADA SOMENTE COM PANO MACIO E MODERADAMENTE UMEDECIDO COM ÁGUA PURA OU SOLUÇÃO COM SABÃO NEUTRO.
- FOR CLEANING, USE ONLY A SOFT CLOTH MODERATELY MOISTENED WITH PURE WATER OR A SOLUTION WITH NEUTRAL SOAP.
- PARA LIMPEZA DEL MUEBLE USAR PAÑO SUAVE Y MODERADAMENTE HUMEDECIDO CON AGUA PURA O SOLUCIÓN CON JABÓN NEUTRO.
- NÃO UTILIZE PRODUTOS QUÍMICOS OU ABRASIVOS, TAIS COMO: CERA, ÁLCOOL, DETERGENTES, TINNER.
- DO NOT USE CHEMICAL OR ABRASIVE PRODUCTS. FOR EXAMPLE: WAX, ALCOHOL, DETERGENT, THINNER.
- NO APLICAR PRODUCTOS QUÍMICOS O ABRASIVOS TAIS COMO: CERAS,ALCOOL, THINNER, DETERGENTE.
- AO SOLICITAR ASSISTÊNCIA TÉCNICA, INFORME O CÓDIGO DO PRODUTO, A COR E O CÓDIGO DA PEÇA CORRETAMENTE.
- WHEN REQUESTING TECHNICAL ASSISTENCE, INFORM THE PRODUCT CODE, THE COLOR AND THE PIECE CODE CORRECTLY.
- SI NECESITAR REPUESTOS, INFORMAR EL CÓDIGO DEL PRODUCTO, EL COLOR Y EL CÓDIGO DE LA PIEZA.



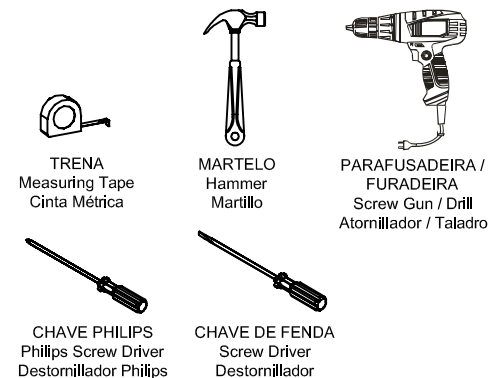







FERRAMENTAS NECESSÁRIAS P/ MONTAGEM.  
 (NÃO SÃO FORNECIDAS)  
 REQUIRED TOOLS FOR ASSEMBLY.  
 (NOT PROVIDED)  
 HERRAMIENTAS NECESSARIAS.  
 (NO PROPORCIONADAS)

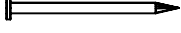



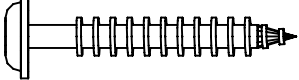

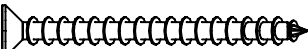
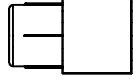
- PESSOAS NECESSÁRIAS P/ MONTAGEM.  
 - REQUIRED PEOPLE FORASSEMBLY.  
 - CANTIDAD DE PERSONAS NECESSARIAS  
 PARA ARMAR.

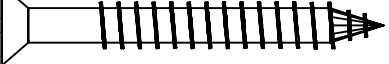

LISTA DE ACESSÓRIO / ACCESSORY LIST / LISTAJE DE ACCESORIO - 1X1

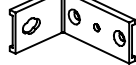
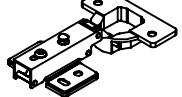
 	<b>A 06</b> 911268 - PARAF. 3,5X12 CHATA CABEÇA 6,8		<b>F 50</b> 904801 - PREGO 09X09
 	<b>B 34</b> 907532 - PARAF. 4,0X12 CABEÇA PANELA		<b>G 12</b> 902913 - CAVILHA 8X30
 	<b>C 04</b> 903557 - PARAF. 5,0X35 FLANGEADO		<b>H 02</b> 900053 - BUCHA 08
 	<b>D 12</b> 903542 - PARAF. 3,5X40		<b>I 12</b> 904980 - SUPORTE DE PRATELEIRA
 	<b>E 02</b> 903563 - PARAF. 6,0X50		

LISTA DE ACESSÓRIO / ACCESSORY LIST / LISTAJE DE ACCESORIO

	<b>J 02</b> 903341 - FIXADOR "L" CANTONEIRA METÁLICA		<b>M 05</b> 910610 - DOBRADIÇA BAIXA C/ AMORTECEDOR
	<b>K 02</b> 901635 - FIXADOR "L" CAPA PLÁSTICA		<b>N 06</b> 910914 - KIT C/ 2 TAPA FURO ADESIVO 13MM
	<b>L 02</b> 911354 - PUXADOR 256MM ESP 15		

\* LIMITE DE PESO MÁXIMO SUPORTADO (KG).  
 \* WEIGHT CAPACITY (KG).  
 \* CAPACIDAD DE PESO (KG).

ESTRUTURA  
 STRUCTURE  
 ESTRUCTURA

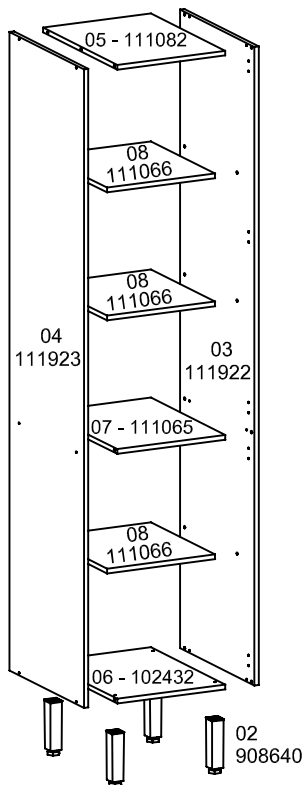

FRENTE  
 FRONT  
 FRENTE



TRASEIRO  
 BOTTOM  
 TRASERO

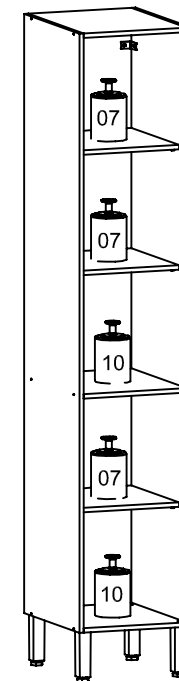
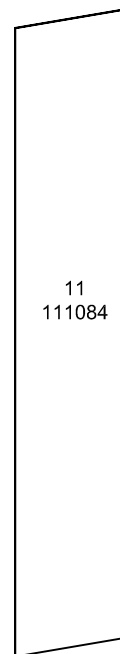

- CONSIDERAR UM PESO BEM DISTRIBUÍDO  
 POR TODO O PRODUTO.  
 - CONSIDER A WELL DISTRIBUTED WEIGHT  
 IN ALL THE PRODUCT.  
 - CONSIDERAR UN PESO BIEN DISTRIBUIDO  
 EN TODO EL PRODUCTO.



① MONTAGEM DA ESTRUTURA.  
 STRUCTURE ASSEMBLY.  
 MONTAJE DE LA ESTRUCTURA.

- B** 04  
PARAFUSO 4,0X12
- C** 04  
PARAFUSO 5,0X35
- D** 12  
PARAFUSO 3,5X40
- I** 12  
SUPORTE DE PRATELEIRA
- G** 12  
CAVILHA 8X30
- J** 02  
FIXADOR L CANT. METAL

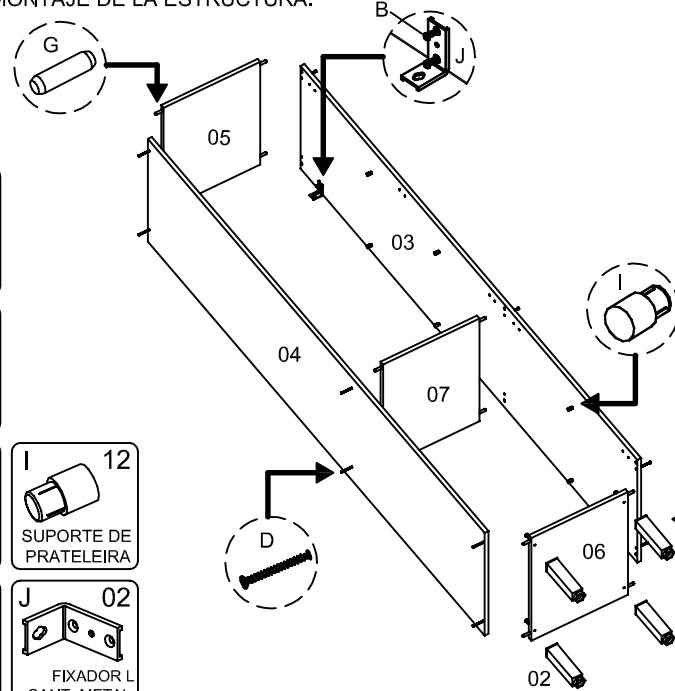

② FIXAÇÃO DO TRASEIRO.  
 BOTTOM ATTACHMENT.  
 FIJACIÓN DEL TRASERO.

- TIRAR ESQUADRO: MEDIR EM CRUZ PELOS CANTOS DO PRODUTO.  
 - SQUARING: MEASURE THE OPPOSITE CORNERS OF THE PRODUCT IN CROSSWISE.  
 - ESCUADRAR: TOMAR LA MEDIDA ENTRE LAS EXTREMIDADES INVERSAS DEL PRODUCTO.

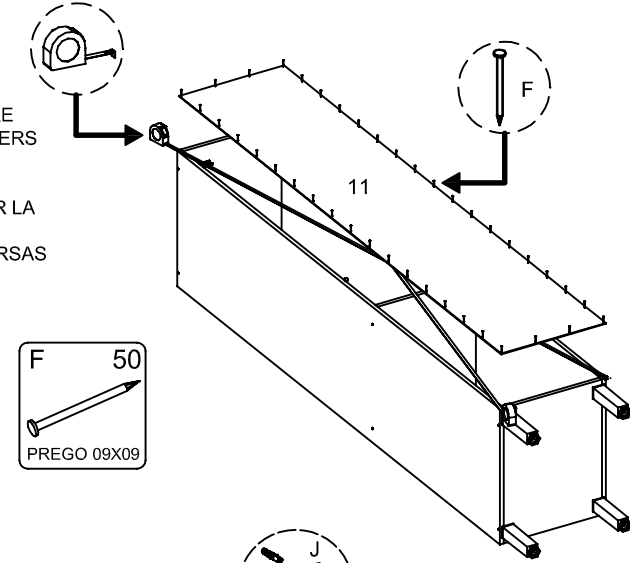

③ COLOCAÇÃO DAS PORTAS E PRATELEIRAS I.  
 DOORS AND SHELVES I PLACEMENT.  
 COLOCACIÓN DE LAS PUERTAS Y REPISAS I.

- A** 06  
PARAFUSO 3,5X12
- K** 02  
FIXADOR L CAPA PLÁSTICA
- B** 30  
PARAFUSO 4,0X12
- L** 02  
PUXADOR
- E** 02  
PARAFUSO 6,0X50
- M** 05  
DOB. ALTA C/ AMORTECEDOR
- H** 02  
BUCHA 08
- N** 06  
KIT C/ 2 TAPA FURO 13MM

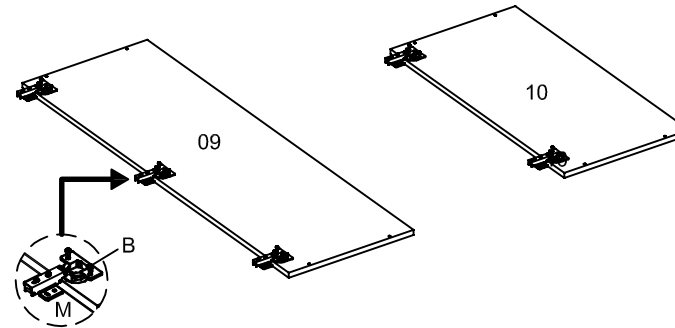

- INFORMAÇÃO AO MONTADOR:  
 USAR PARAFUSADEIRA NO TORQUE BAIXO!  
 - INFORMATION TO THE ASSEMBLER:  
 USE THE CORDLESS DRILL AT LOW TORQUE.  
 - INFORMACIÓN AL ARMADOR:  
 UTILIZAR ATORNILLADOR EN TORQUE FLACO.

A ABERTURA DA PORTA PODE SER À DIREITA OU À ESQUERDA.  
 THE DOOR OPENING CAN BE TO THE RIGHT OR TO THE LEFT.  
 LA ABERTURA DE LA PUERTA PUEDE SER A LA DERECHA O IZQUIERDA.

