

Torre Quente 2 Fornos Belize

Torre Caliente 2 Hornos Belize | Hot Tower 2 Belize Ovens
c C513-131 - Cinza

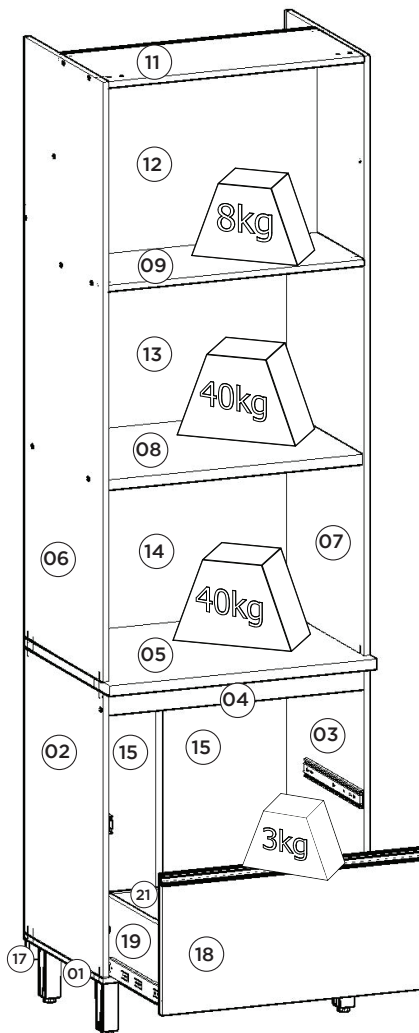
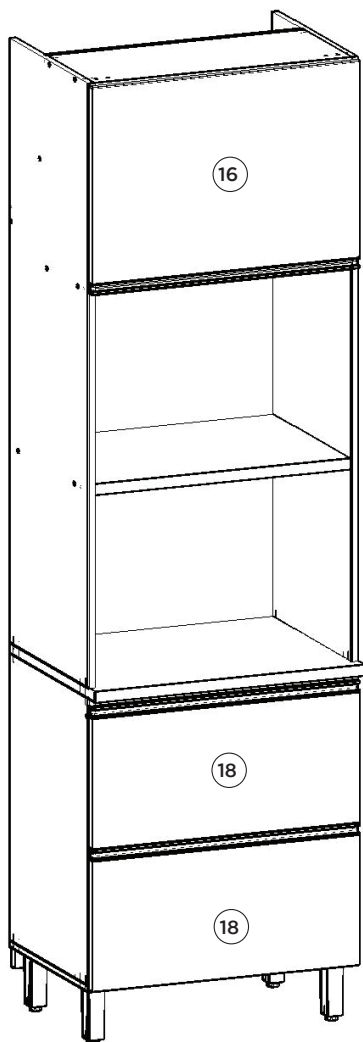

Pesos máximos recomendados com carga distribuída
Peso máximo recomendado con la carga distribuida
Recommended maximum weights with evenly distributed.

Requisitos para montagem Requisitor para la montaje Assembly Requirements

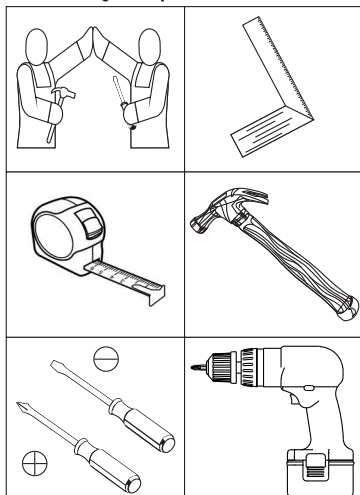

Imagens meramente ilustrativas
Imágenes meramente ilustrativas
Images for illustration only

AVISO

Para limpeza de seu móvel, use uma flanela seca ou umedecida, e não utilize produtos químicos que possam danificar seu produto.

SISTEMA DE MONTAGEM

O sistema de montagem dos produtos, funciona de acordo com a ordem crescente dos números indicados no desenho. Ex: 01, 02, 03, 04... até a conclusão da montagem.

ADVERTENCIA

Para limpieza de su móvil, use una flanela seca o húmeda, y no utilice productos químicos que puedan dañar su producto.

SISTEMA DE MONTAJE

El sistema de montaje de los productos funciona de acuerdo con el orden creciente de los números indicados en el dibujo. Ej.: 01, 02, 03, 04... hasta la conclusión del montaje.

NOTICE

To clean your furniture, use a dry or wet cloth, and do not use chemicals that may damage your product.

ASSEMBLY SYSTEM

The products' assembly system works according to the increasing order of the indicated numbers. For example: 01, 02, 03, 04 ... to the end of the assembly.

1°

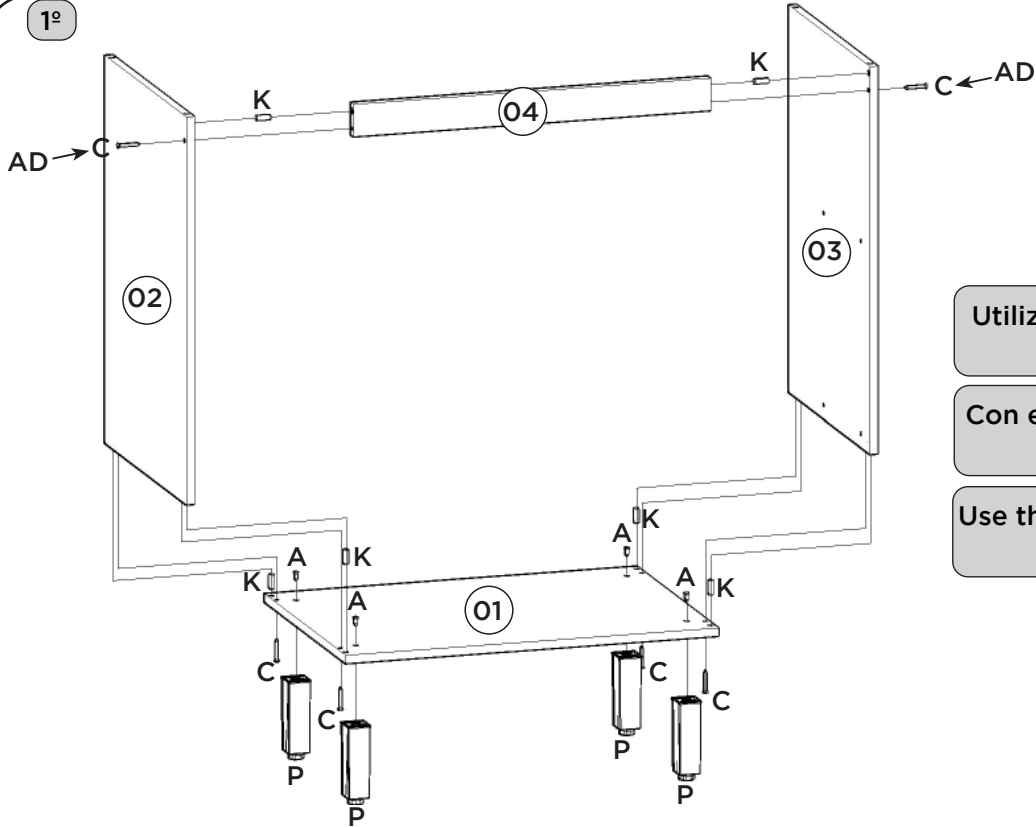

Utilizar o sachê de cola (AA) em todas as cavilhas (K) do produto.

Con el pegamento sobre (AA) en todos los pernos (K) producto.

Use the glue sachet (AA) on all the pegs (K) of the product.

2°

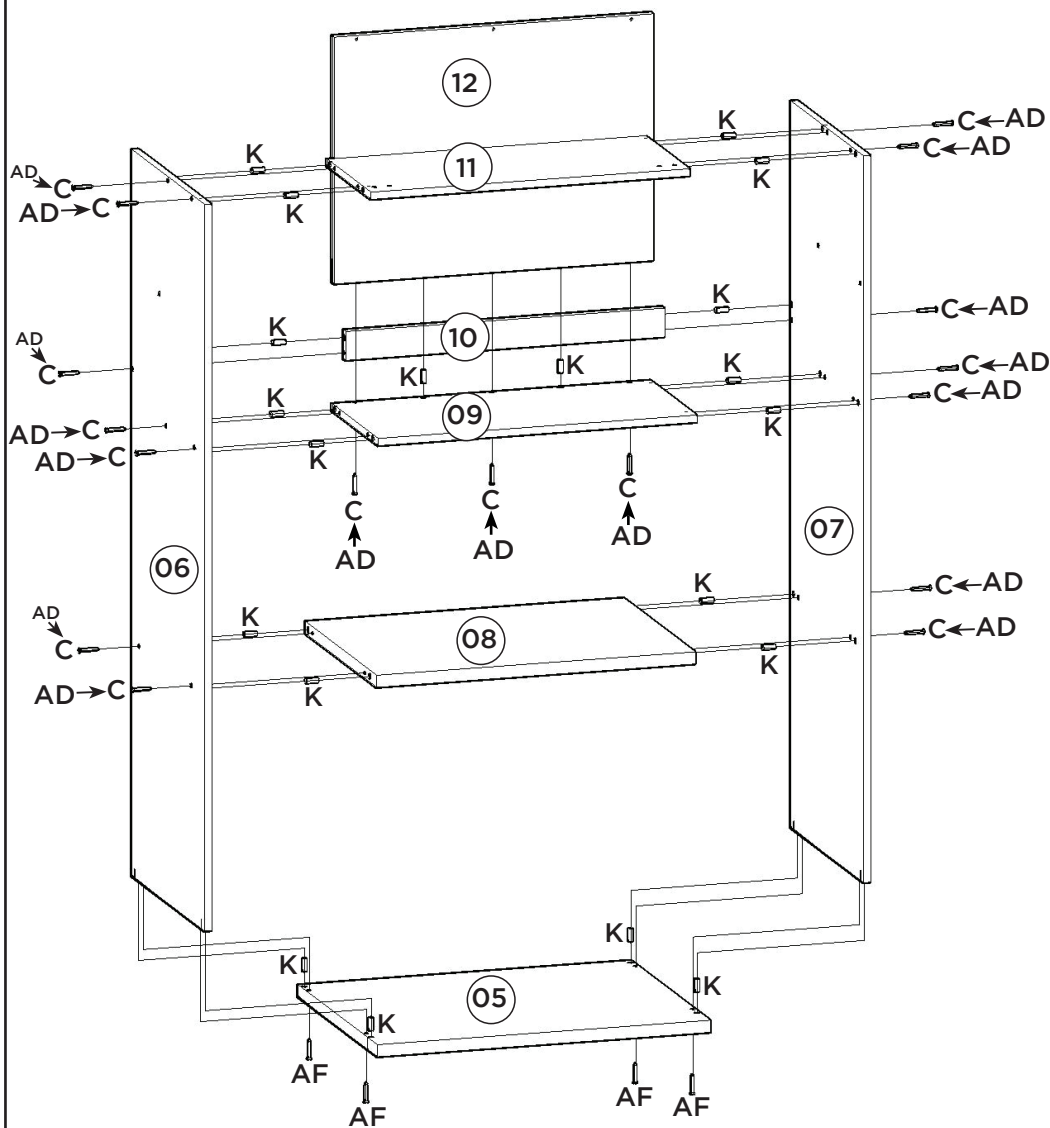

3°

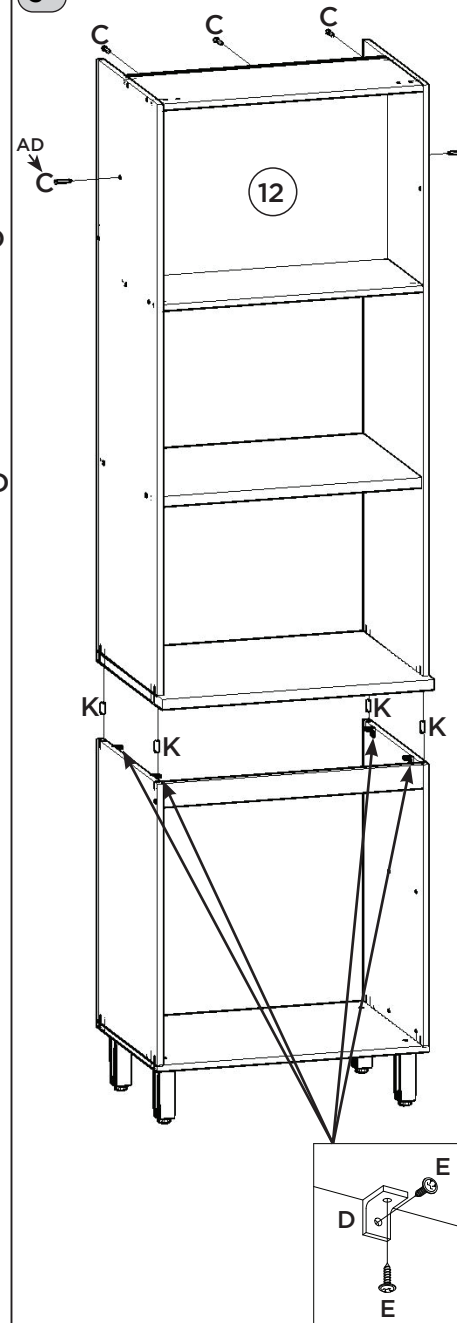

4º

ATENÇÃO: Por questão de segurança, recomendamos a não utilização do Fundo (12) caso o espaço seja utilizado por forno elétrico ou forno embutido, dessa forma, haverá melhor propagação do calor, evitando danos em seu móvel.

ADVERTENCIA: Por razones de seguridad, se recomienda no utilizar el Fondo (12) si el espacio es utilizado por horno eléctrico o una función de horno, de esta manera no será mejor propagación del calor, evitando el daño a su móvil.

ATTENTION: For safety reasons, we recommend not using the Fund (12) if the space is used by an electric oven or built-in oven, in this way, there will be better propagation of the heat, avoiding damage to your furniture.

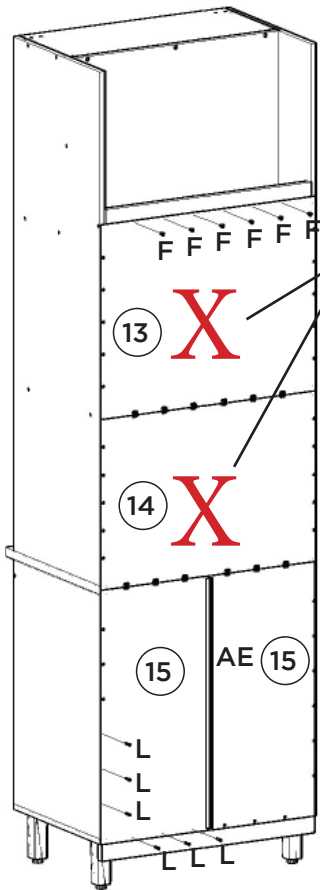

5º



Video: Instalar e regular Dobradiças

Video: Instale y ajuste las bisagras

Video: Install and adjust hinges

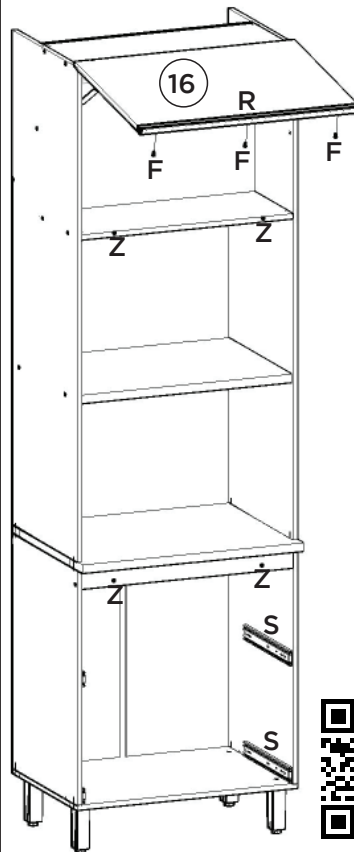

Video: Dicas para instalar o Kit Pistão à Gás

Video: Consejos para instalar el kit de pistón de gas

Video: Tips for installing the Gas Piston Kit

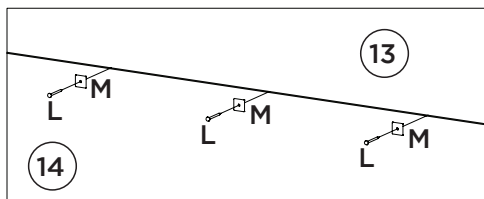
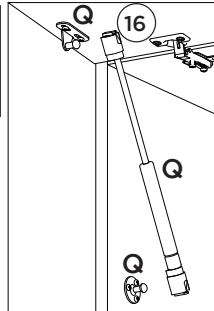
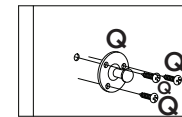
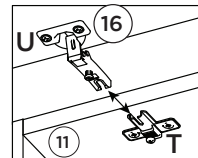
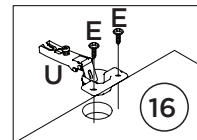
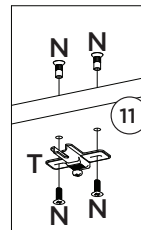

Video: Dicas para fixar a Corrediça

Video: Consejos para arreglar la diapositiva

Video: Tips for Fixing the Slide

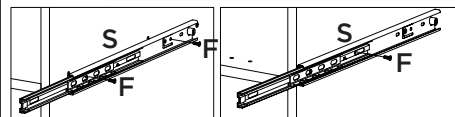

6º Opção Suspensa Opción suspendida
Suspended Option

Parede
pared
Wall

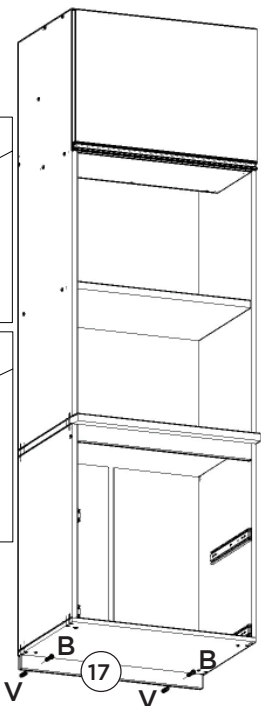
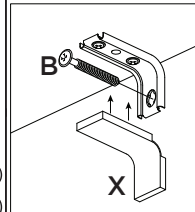
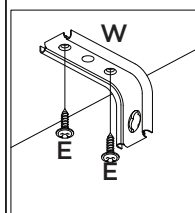

7º Gaveta 02x Cajone 02x Drawer 02x

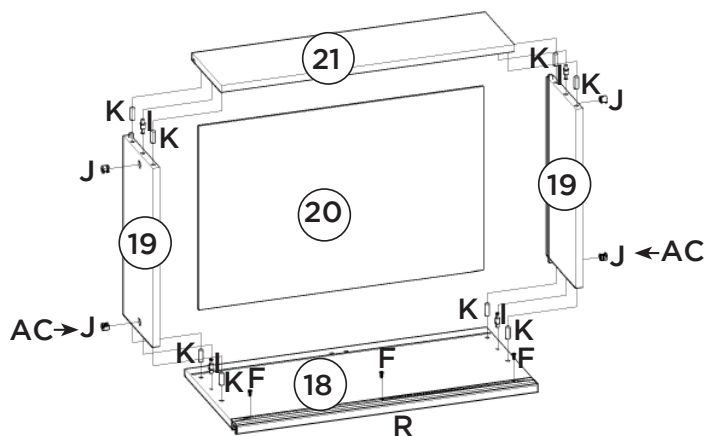

Video: Dicas para fixar o Minifix

Video: Consejos para arreglar Minifix

Video: Tips for Fixing Minifix

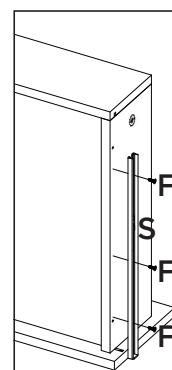
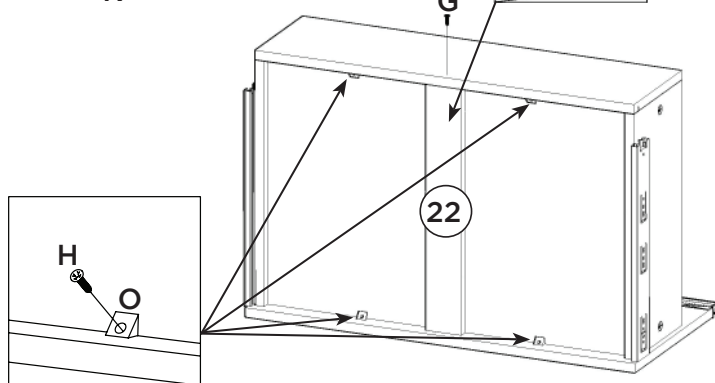

Item	Caixa Caja Box	Qty Ctd Qty	Descrição Descripción Description	Medidas (mm) Dimensions (mm) Size (measurements) (mm)
01	2/2	01	Base Base Base	700x490x15
02	1/2	01	Lateral Esquerda Inferior Lateral Izquierda Inferior Left Side Lower	715x490x15
03	1/2	01	Lateral Direita Inferior Lateral Derecha Inferior Right Side Bottom	715x490x15
04=10	1/2	01	Travessa Frontal Travesaño delantero Front cross member	669x60x15
05	2/2	01	Tampo 25mm Tapa 25mm Top 25mm	700x533x25
06	1/2	01	Lateral Esquerda Superior Lado Izquierdo Superior Upper Left Side	1500x490x15
07	1/2	01	Lateral Direita Superior Lateral Derecha Superior Right Side Superior	1500x490x15
08	2/2	01	Prateleira 25mm Estantería 25mm Shelf 25mm	669x480x25
09	2/2	01	Prateleira Central Prateleira Central Central Shelf	669x310x15
10=04	1/2	01	Travessa Frontal Travesaño delantero Front cross member	669x60x15
11	2/2	01	Tampo Tapa Top	669x295x15
12	2/2	01	Fundo 15mm 15 mm inferior Bottom 15mm	669x510x15
13	2/2	01	Fundo Superior Fondo superior Superior background	693x566x3
14	2/2	01	Fundo central Fondo central Central fund	693x496x3
15	1/2	02	Fundo Cru Fondo Crudo Raw Background	742x343x3
16	1/2	01	Porta Basculante Puerta Basculante Tilting Door	696x490x15
17	1/2	01	Travessa Sustentação Travessa Ayuda Support Travessa	690x50x15
18	1/2	02	Frente de gaveta Frente de cajón Front of drawer	696x326x15
19	1/2	04	Lado de Gaveta Lado del cajón Drawer Side	400x180x15
20	1/2	02	Fundo de gaveta Fondo de cajón Bottom of drawer	625x411x3
21	1/2	02	Ripa de trás Malla detrás Rear lath	644x180x15
22	1/2	02	Ripa Estrutural Gaveta Ripa Estructural Cajón Drawer Structural Clamp	400x60x15

Ferragens | Herrajes | Hardware

A Parafuso 7,0x40mm CHT. Tornillo 7,0x40mm CHT. Screw 7,0x40mm CHT.	B Parafuso 5,0x50mm FLA. Tornillo 5,0x50mm FLA. Screw 5,0x50mm FLA.	C Parafuso 3,5x40mm CHT. Tornillo 3,5x40mm CHT. Screw 3,5x40mm CHT.	D Cantoneira plástica Cantoneira plástica Plastic angle brackets	E Parafuso 3,5x14mm FLA. Tornillo 3,5x14mm FLA. Screw 3,5x14mm FLA.	F Parafuso 3,5x12mm CHT. Tornillo 3,5x12mm CHT. Screw 3,5x12mm CHT.	G Parafuso 3,0x30mm CHT. Tornillo 3,0x30mm CHT. Screw 3,0x30mm CHT.
H Parafuso 3,0x16mm CHT. Tornillo 3,0x16mm CHT. Screw 3,0x16mm CHT.	I Parafuso minifix Tambor minifix Minifix bolt	J Tambor minifix Tambor minifix Minifix drum	K Cavilha 8x25mm Cinta 8x25mm Dowel 8x25mm	L Prego 10x10mm Clavo 10x10mm Nail 10x10mm	M Fixador de fundos Fijador de fondos Bottom fixer	N Parafuso União 15mm Tornillo Unión 15mm Union Screw 15mm
O Cantoneira suporte triangular Cantoneira suporte triangular Triangle support angle	P Pé 145mm x 42mm Pie 145mm x 42mm Foot 145mm x 42mm	Q Kit Pistão a Gás 50N Kit Pistón a Gas 50N 50N Gas Piston Kit	R Puxador MOV4083 - 696mm Tirador MOV4083 - 696mm MOV4083 - 696mm Handle	S Corrediça telescópica Diapositivas telescópicas Telescopic slides	T Calço metal metal 0mm Calzado metal metal 0mm Metal metal shim 0mm	U Dobradiça metal 35mm Colo Baixo Bisagra de metal 35mm Colo Bajo Metal hinge 35mm Colo Low
V Buchsa plástica 8mm Buchsa de plástico 8mm 8mm plastic bushing	W Suporte de fixação Soporte de fijación Mounting bracket	X Proteção para cantoneira Ángulo de protección Protection angle	Y Parafuso União 30mm Tornillo Unión 30mm Union Screw 30mm	Z Batente PVC para Porta Parada de PVC para Puerta PVC Door Stop	AA Sachê de cola Bolsa de pegamento Glue bag	AB Giz de correção Tiza de corrección Chalk of correction
AC Adesivo tampa parafuso 17mm Adhesivo tapón de tornillo 17mm Bolt cover adhesive 17mm	AD Adesivo tampa parafuso 10mm Adhesivo tapón de tornillo 10mm Bolt cover adhesive 10mm	AE Perfil "H" 728mm Perfil "H" 728mm Profile "H" 728mm	AF Parafuso 4,5x50mm CHT. Tornillo 4,5x50mm CHT. Screw 4,5x50mm CHT.	AG Etiqueta resinada Henn Etiqueta resinada Henn Henn resin label		



O parafuso (Y) deve ser usada somente quando este módulo for acoplado a outro módulo componível Henn.

RECOMENDAÇÃO

Para fixar o móvel na parede usar o suporte de fixação (W), o parafuso 3,5x14mm FLA (E), a Buchsa 8mm (V) e o parafuso 5,0x50mm FLA (B).



El tornillo (Y) se debe utilizar sólo cuando el módulo está conectado a otro módulo componible Henn.

RECOMENDACIÓN

Para conectar el móvil a la pared con el soporte (W), tornillo 3,5 x14mm FLA (E), el casquillo de 8 mm (V) y el 5,0 x50mm tornillo FLA (B).



The screw (Y) should be used only when this module is attached to another Henn modular module.

RECOMMENDATION

To fix the furniture to the wall use the mounting bracket (W), the 3.5x14mm FLA (E) screw, the 8mm bushing (V) and the 5.0x50mm FLA (B).