

## PENTEADEIRA CAMARIM LAS VEGAS

Las Vegas dressing table  
Tocador Las Vegas

Código 160212 | Revisão 04

Código 180762 | Revisão 04

### IMPORTANT! / IMPORTANT! / ¡IMPORTANTE!

- A fiação elétrica, os soquetes das lâmpadas e o interruptor acompanham o produto;
  - lâmpadas NÃO estão inclusas;
  - utilize lâmpadas bulbo LED E27 de 3w a 6w de potência.
- 
- Electrical wiring, lamp sockets, and switch are included with the product;
  - lamps are NOT included;
  - use E27 LED bulbs from 3w to 6w power output.
- El cableado eléctrico, los sockets de las lámparas y el interruptor siguen con el producto;
  - las lámparas NO están incluidas
  - utilice lámparas de LED E27 de 3w hasta 6w de potencia

### PESO MÁXIMO SUPORTADO PELAS PEÇAS, SENDO ESTE DISTRIBUÍDO UNIFORMEMENTE.

Maximum weight supported by parts, being this evenly distributed.  
Peso máximo soportado por las partes, siendo esta distribuido uniformemente.

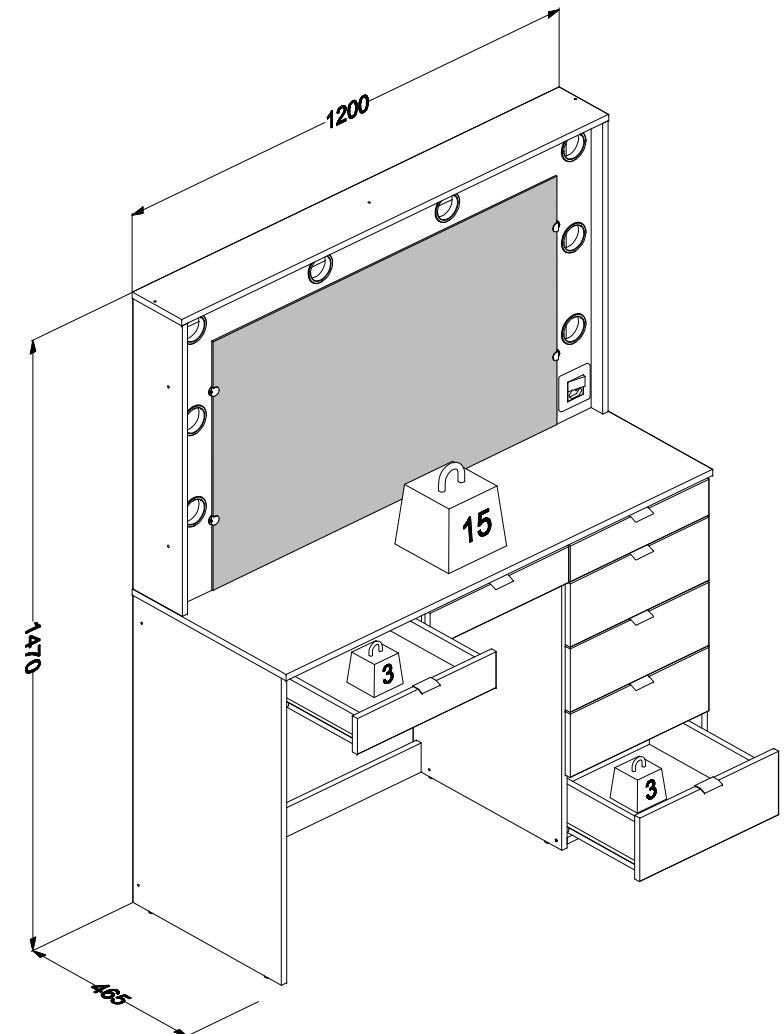

Você vai precisar de/ You will need / Usted necesitará

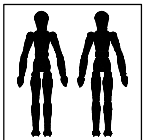

2 Pessoas  
2 People  
2 Personas

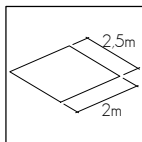

Espaço recomendado para montagem  
Recommended space for assemble  
Espacio recomendado para el armado

Ferramentas não inclusas  
Tools not included / Herramientas no incluidas

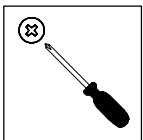

Chave Phillips  
Screwdriver Phillips  
Destornillador cruz

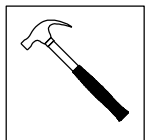

Martelo  
Hammer  
Martillo











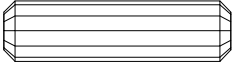
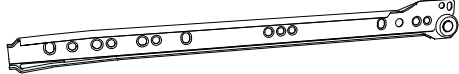
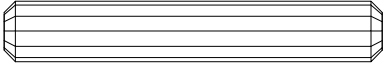
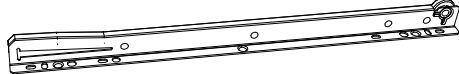

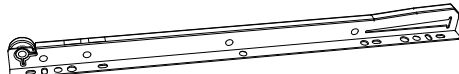
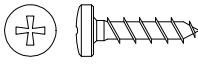
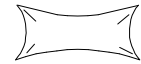
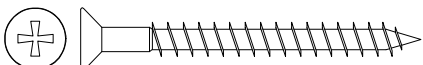

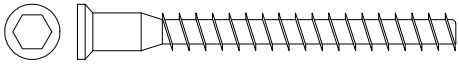

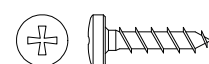

\* PESO EM KG/ Weight in Kg/ Peso en Kg  
DIMENSÕES EM MM/ Dimensions in mm/ Dimensiones en mm

**IDENTIFICAÇÃO DOS ACESSÓRIOS/ IDENTIFICATION OF ACCESSORIES/ IDENTIFICACIÓN DE ACCESORIOS**

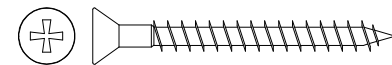
**NOTAS:** A separação dos acessórios antes de iniciar a montagem facilitará a mesma. Os parafusos e cavilhas estão na escala real. Em caso de dúvida na identificação, coloque o acessório sobre a imagem.

**NOTES:** The separation of the accessories before you start the assembly will facilitate the same. The screws and dowels are in real scale. In case of doubts about the identification, place the accessory on the image.

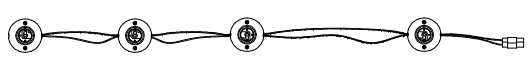
**NOTAS:** La separación de los accesorios antes de comenzar el armado facilitará el mismo. Los tornillos y taquetes son en escala real. En caso de dudas sobre la identificación, coloque el accesorio en la imagen.

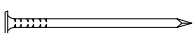
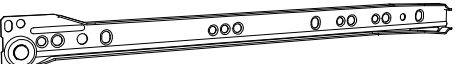
<b>A</b>		<b>Cavilha</b> Wooden Dowel Taquete	8x30 mm	<b>70</b>	<b>Q</b>		<b>Corrediça lateral direita</b> Metallic slide the right field Corredera lateral derecha	350 mm	<b>07</b>
<b>B</b>		<b>Cavilha</b> Wooden Dowel Taquete	8x50 mm	<b>04</b>	<b>R</b>		<b>Corrediça gaveta esquerda</b> Drawer slide left Corredera izquierda cajón	350 mm	<b>07</b>
<b>C</b>		<b>Parafuso chato</b> Flat head screw Tornillo de cabeza plana	3,0x14 mm	<b>62</b>	<b>S</b>		<b>Corrediça gaveta direita</b> Drawer slide right Corredera derecha cajón	350 mm	<b>07</b>
<b>D</b>		<b>Parafuso panela</b> Pan head screw Tornillo de pan	3,5x14 mm	<b>24</b>	<b>T</b>		<b>Cola</b> Glue Pegamento	13g	<b>01</b>
<b>F</b>		<b>Parafuso chato</b> Flat head screw Tornillo de cabeza plana	4,5x45 mm	<b>17</b>	<b>U</b>		<b>Junção de tampos</b> Junction of tops Unión de tapas	40x40 mm	<b>02</b>
<b>G</b>		<b>Parafuso estrutural</b> Structural screw Tornillo estrutural	5,0x50 mm	<b>15</b>	<b>V</b>		<b>Colarinho</b> Collar Cuello	60 mm	<b>08</b>
<b>H</b>		<b>Chave allen</b> Allen key Llave Allen	-	<b>01</b>	<b>Y</b>		<b>Parafuso panela cromado</b> Chrome pan head screw Tornillo olla cromo	3,5x14 mm	<b>04</b>
<b>I</b>		<b>Tampa parafuso estrutural</b> Structural screw cover Tapa tornillo estrutural	-	<b>13</b>	<b>Z</b>		<b>Puxador</b> Handle Tirador	-	<b>07</b>
<b>J</b>		<b>Haste minifix simples</b> Simple minifix screw Tornillo minifix simple	-	<b>22</b>	<b>AA</b>		<b>Parafuso chato</b> Flat head screw Tornillo de cabeza plana	6,0x08 mm	<b>08</b>
<b>K</b>		<b>Tambor minifix</b> Drum lock Tambor minifix	12 mm	<b>22</b>	<b>AB</b>		<b>Parafuso chato</b> Flat head screw Tornillo de cabeza plana	4,0x40 mm	<b>01</b>
<b>L</b>		<b>Tapa furo adesivo</b> Bore patch adhesive Taponos adhesivo	-	<b>14</b>	<b>AC</b>		<b>Suporte de prateleira</b> Shelf bracket Soporte de repisa	6x8 mm	<b>04</b>
<b>M</b>		<b>Suporte espelho</b> Mirror support Suporte espejo	-	<b>04</b>	<b>BA</b>		<b>Chicote elétrico parte 1</b> Electric cable part 1 Cable eléctrico parte 1	-	<b>01</b>
<b>N</b>		<b>Sapata redonda</b> Small plastic foot Pie plástico	14 mm	<b>06</b>	<b>BB</b>		<b>Chicote elétrico parte 2</b> Electric cable part 2 Cable eléctrico parte 2	-	<b>01</b>
<b>O</b>		<b>Prego</b> Nail Clavo	10 x10	<b>28</b>					
<b>P</b>		<b>Corrediça lateral esquerda</b> Metallic slide the left field Corredera lateral izquierda	350 mm	<b>07</b>					

IDENTIFICAÇÃO DAS PEÇAS/ PARTS IDENTIFICATION/ IDENTIFICACIÓN DE LAS PIEZAS

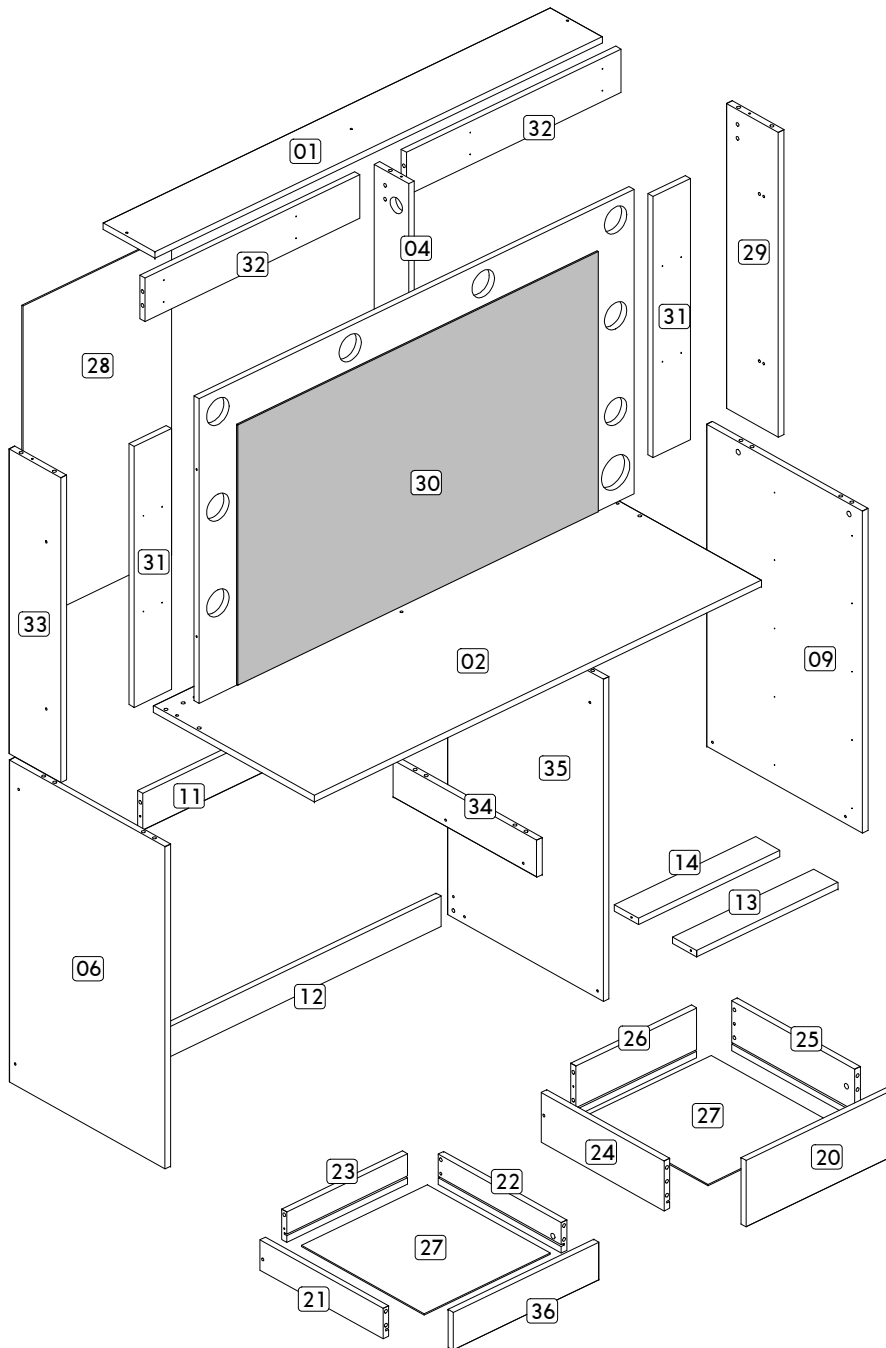

Nº	DESCRIÇÃO - DESCRIPTION - DESCRIPCIÓN	MEDIDAS-MEASURES - MEDIDAS (mm)	QTD.
01	Base superior - Top base - Base superior	1202 x 150 x 15	01
02	Tampo - Top - Tapa	1200 x 465 x 15	01
04	Divisão superior - Upper division - División superior	700 x 100 x 15	01
06	Lateral esquerda inferior - Left bottom side - Lateral izquierda inferior	740 x 450 x 15	01
09	Lateral direita inferior - Right bottom side - Lateral derecha inferior	740 x 450 x 15	01
11	Travessa gaveta - Drawer tray - Traviesa cajon	773 x 85 x 15	01
12	Rodapé - Footer - Zocalo	773 x 70 x 15	01
13	Travessa frontal - Front tray - Traviesa frontal	379 x 70 x 15	01
14	Travessa traseira - Rear tray - Traviesa trasera	379 x 70 x 15	01
20	Frente de gaveta - Drawer front - Frente del cajón	391 x 153 x 15	04
21	Lateral esquerda de gaveta menor - Left side of drawer - Lateral izquierda del cajón	355 x 70 x 15	03
22	Lateral direita de gaveta menor - Right side of drawer - Lateral derecha del cajón	355 x 70 x 15	03
23	Traseiro de gaveta menor - Smaller rear of drawer - Trasero del cajón menor	324 x 70 x 15	03
24	Lateral esquerda de gaveta - Left side of drawer - Lateral izquierda del cajón	355 x 115 x 15	04
25	Lateral direita de gaveta - Right side of drawer - Lateral derecha del cajón	355 x 115 x 15	04
26	Traseiro de gaveta - Rear of drawer - Trasero del cajón	324 x 115 x 15	04
27	Fundo de gaveta - Bottom of drawer - Fondo del cajón	354 x 338 x 3	07
28	Costa - Backboard - Fondo	736 x 399 x 3	01
29	Lateral direita superior - Right upper side - Lateral derecha superior	700 x 150 x 15	01
30	Painel espelho - Mirror panel - Panel espejo	1167 x 700 x 15	01
31	Painel lateral lampadas - Side lamps panel - Panel superior lámparas	600 x 100 x 15	02
32	Painel superior lampadas - Upper panel lamps - Panel superior lámparas	576 x 100 x 15	02
33	Lateral esquerda superior - Left upper side - Lateral izquierda superior	700 x 150 x 15	01
34	Divisão gavetas - Drawer division - División cajon	415 x 85 x 15	01
35	Divisão inferior - Bottom division - División inferior	740 x 450 x 15	01
36	Frente de gaveta menor - Smaller drawer front - Frente del cajón menor	391 x 85 x 15	03

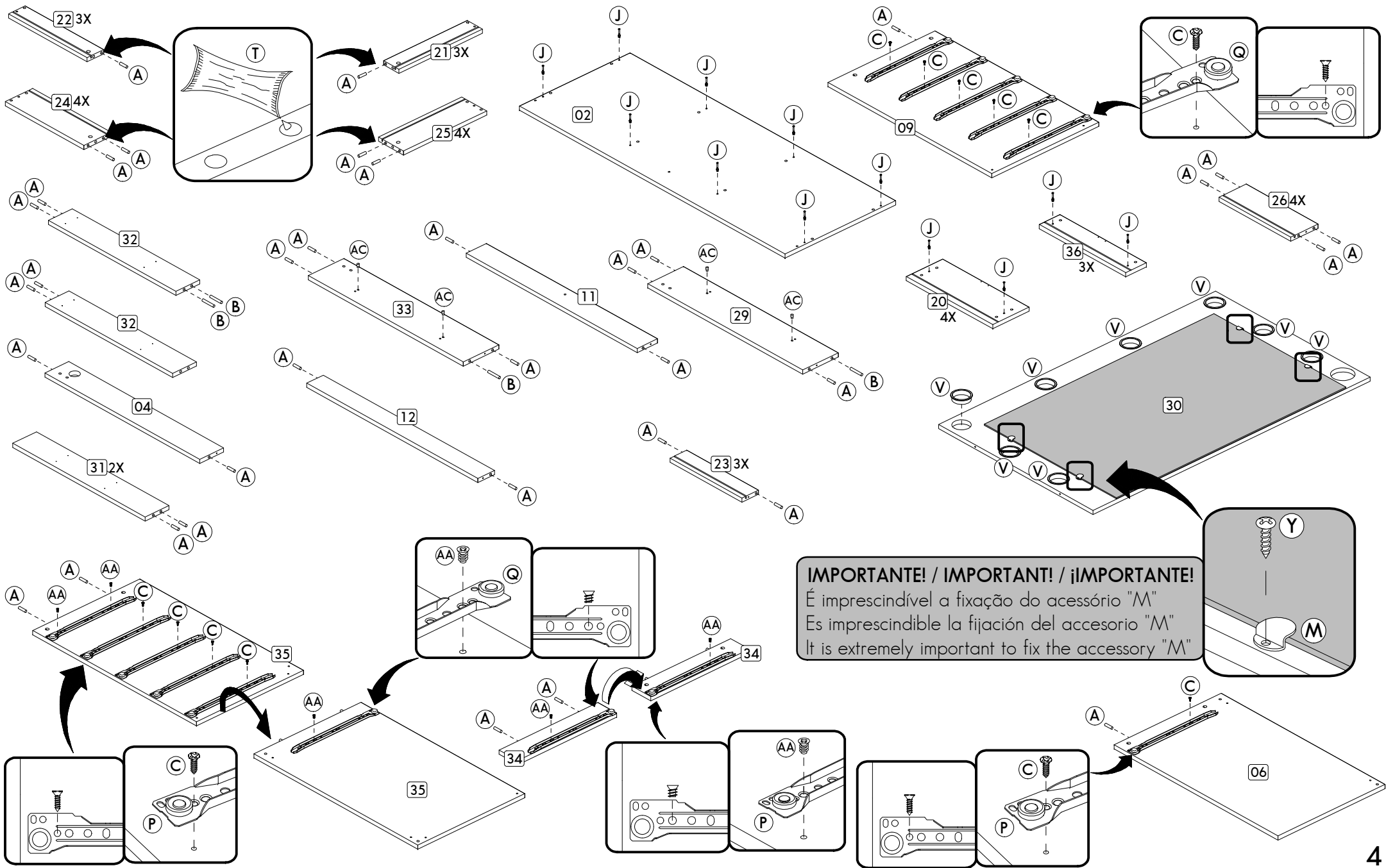

**IMPORTANTE! / IMPORTANT! / ¡IMPORTANTE!**  
 É imprescindível a fixação do acessório "M"  
 Es imprescindible la fijación del accesorio "M"  
 It is extremely important to fix the accessory "M"

Passo/ Step/ Paso 01

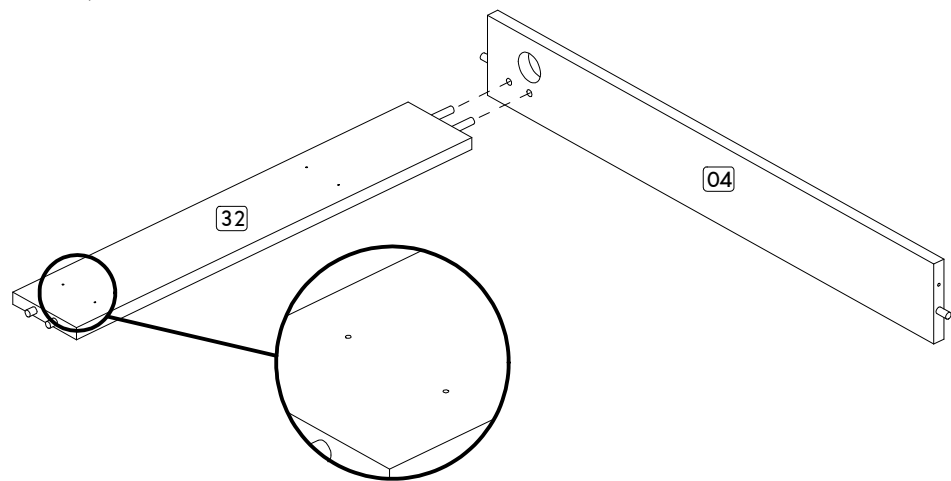

Passo/ Step/ Paso 02

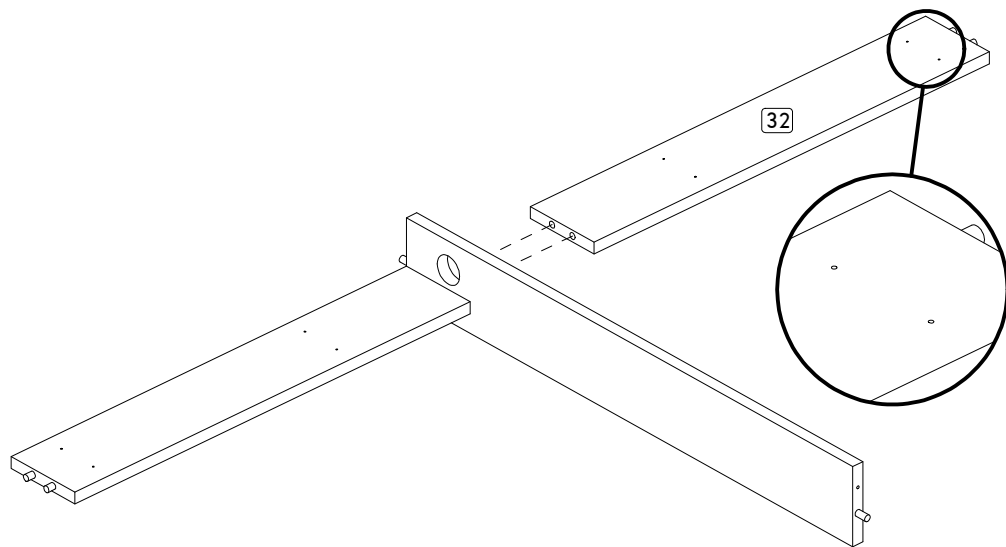

Passo/ Step/ Paso 03

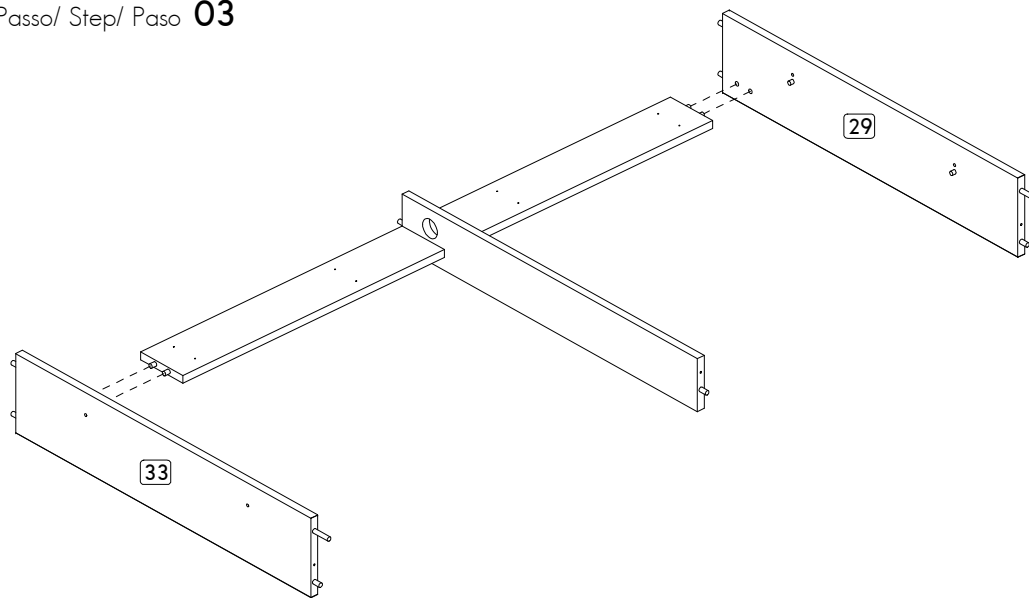

Passo/ Step/ Paso 04

**NOTA!**

A fixação por parafusos da peça 01 se dará no passo 20. Isso se deve para facilitar a colocação do painel 30 posteriormente.

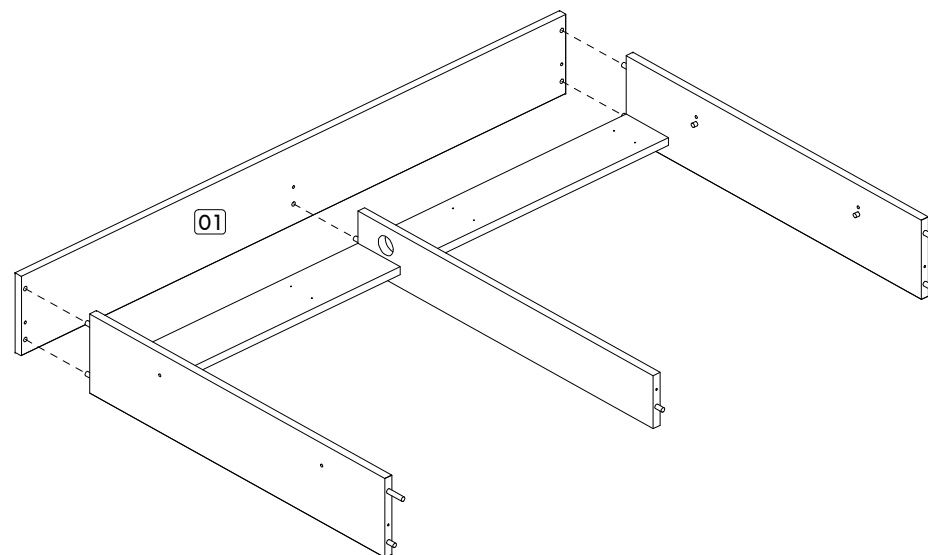

Passo/ Step/ Paso 05

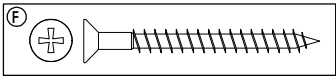
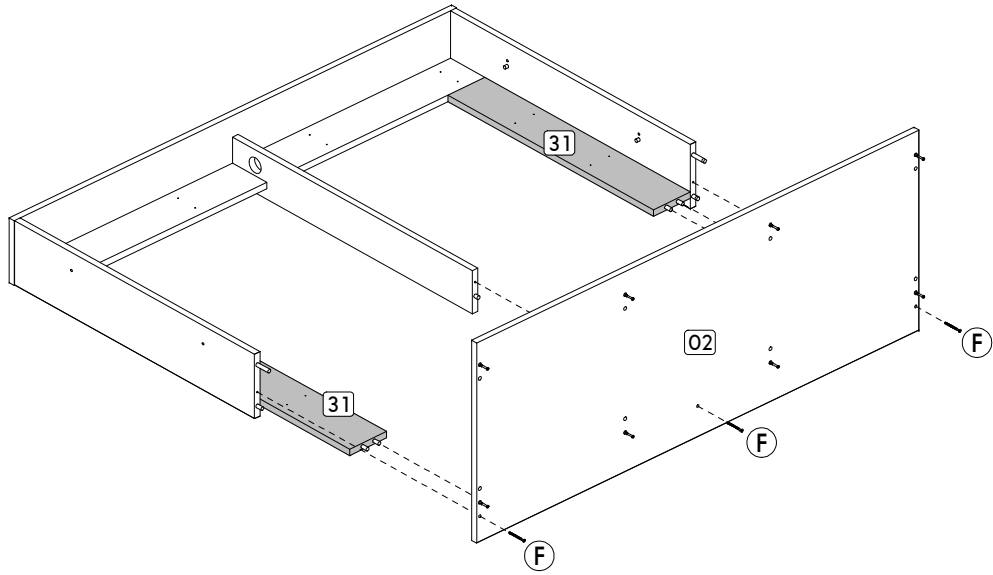

Passo/ Step/ Paso 06

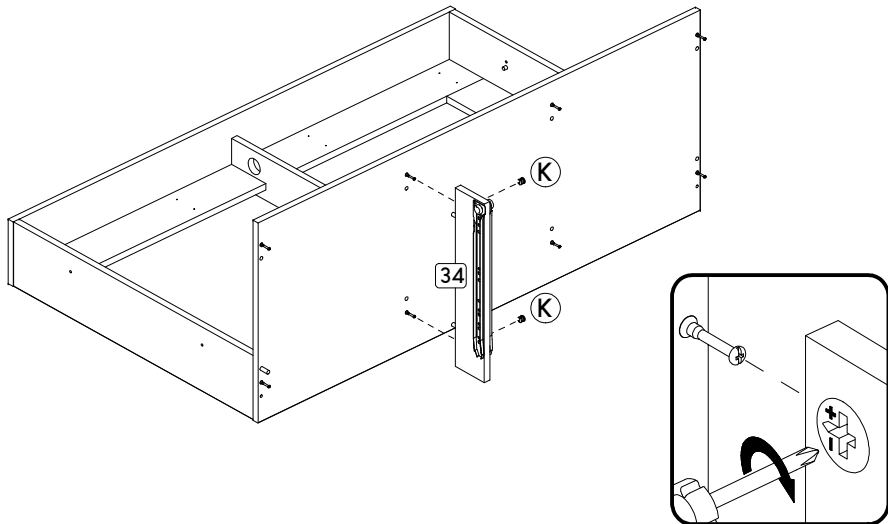

Passo/ Step/ Paso 07

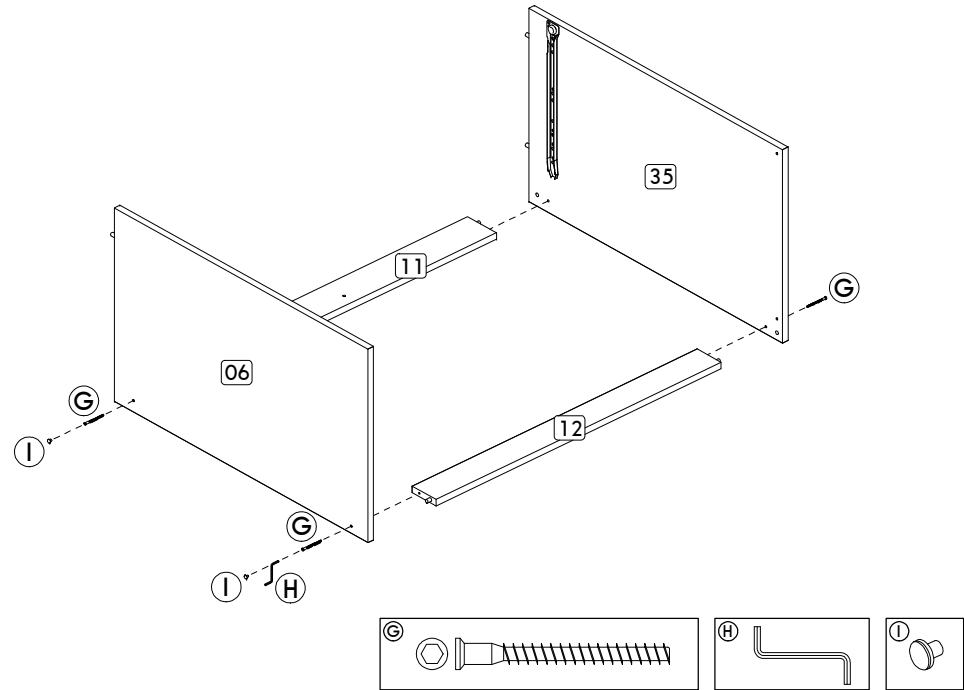

Passo/ Step/ Paso 08

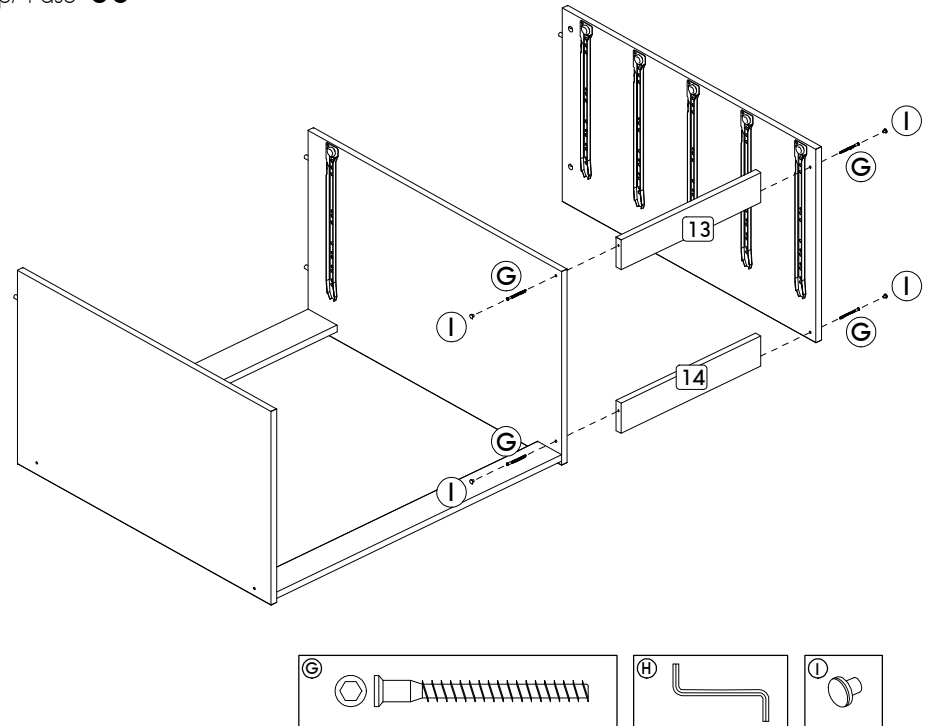

Passo/ Step/ Paso 09

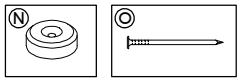
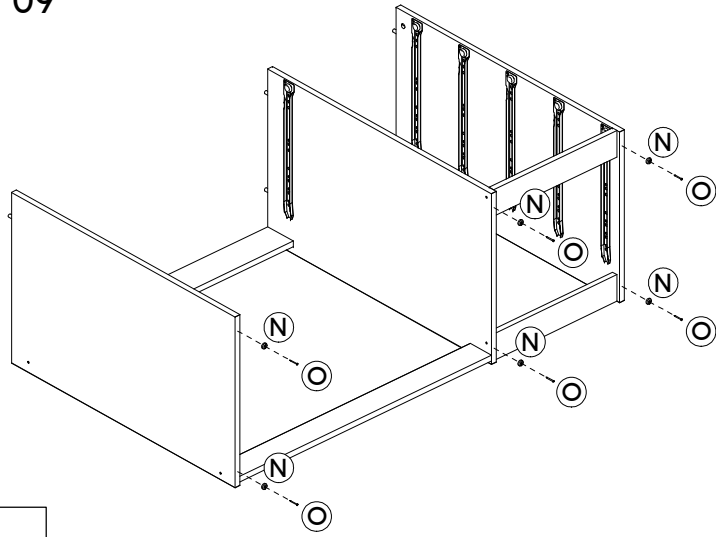

Passo/ Step/ Paso 10

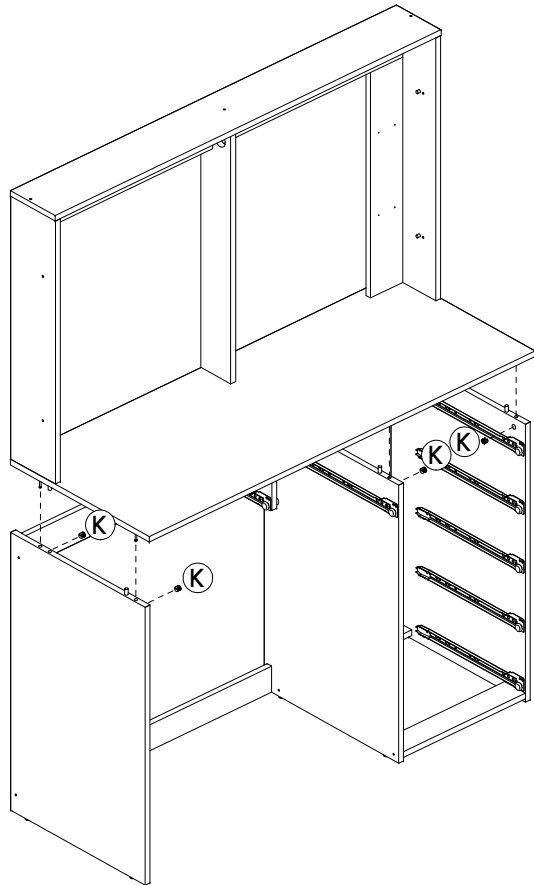

Passo/ Step/ Paso 11

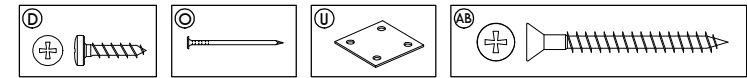
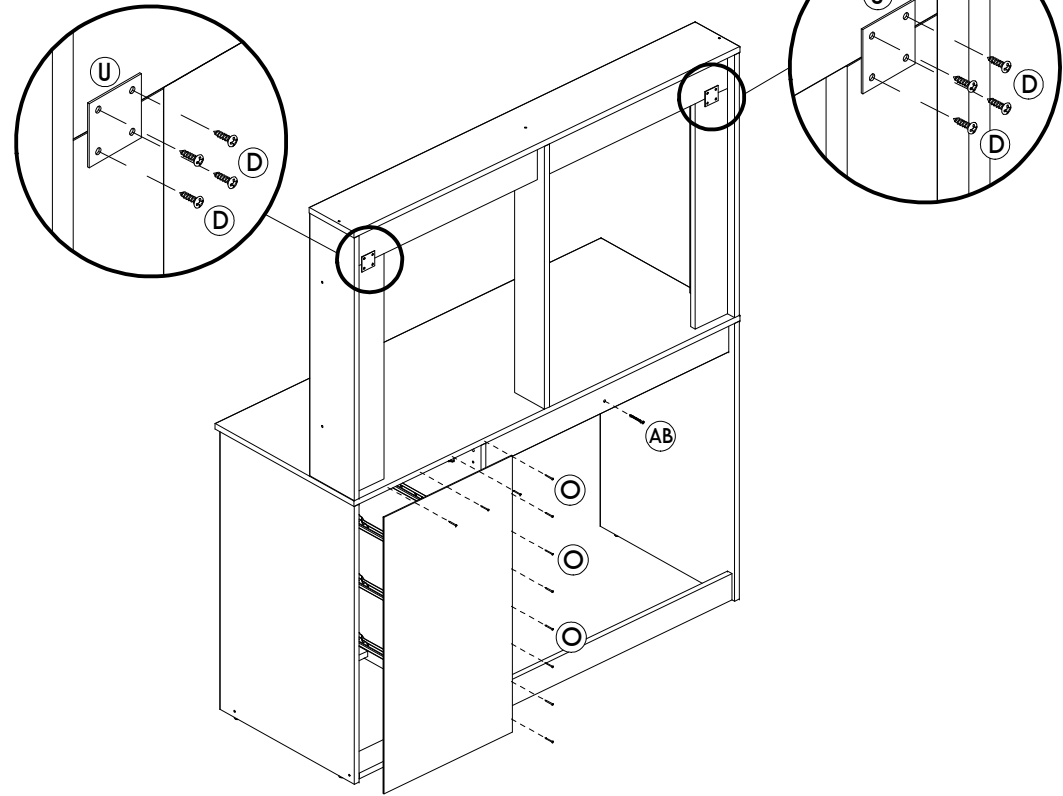

Passo/ Step/ Paso 12

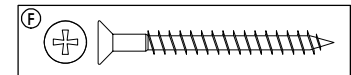
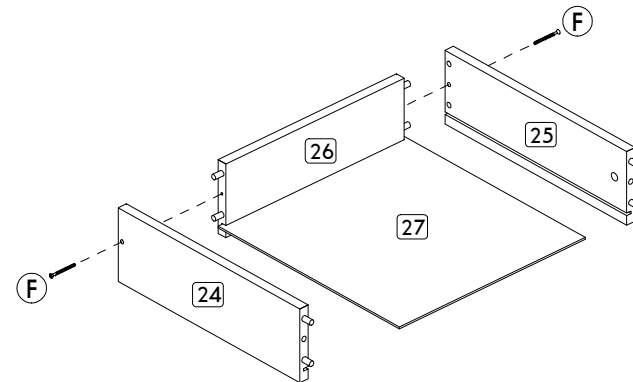

Passo/ Step/ Paso 13

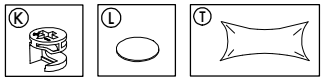
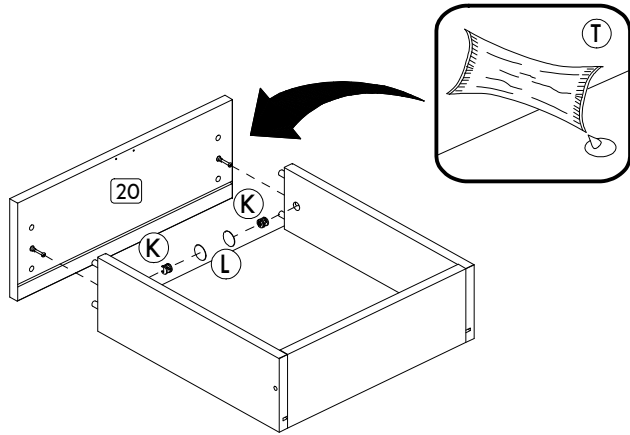

Passo/ Step/ Paso 14

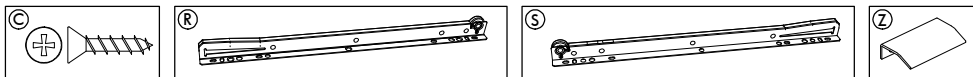
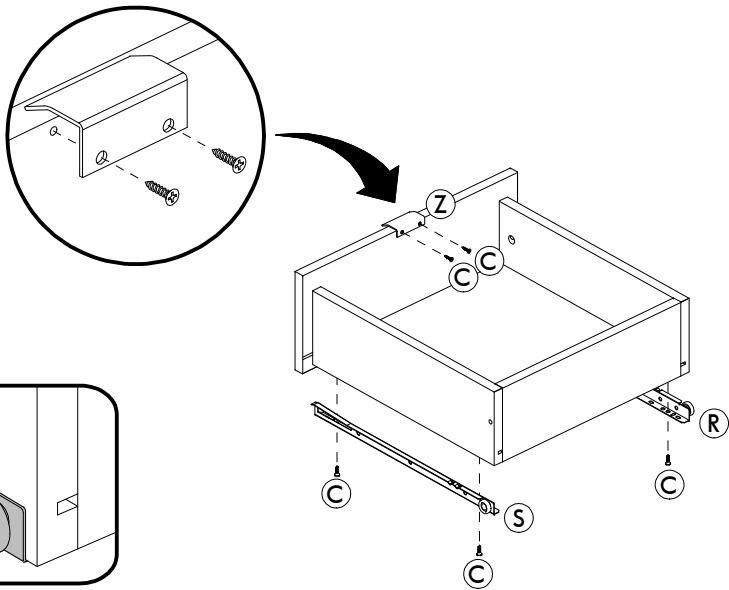

Passo/ Step/ Paso 15

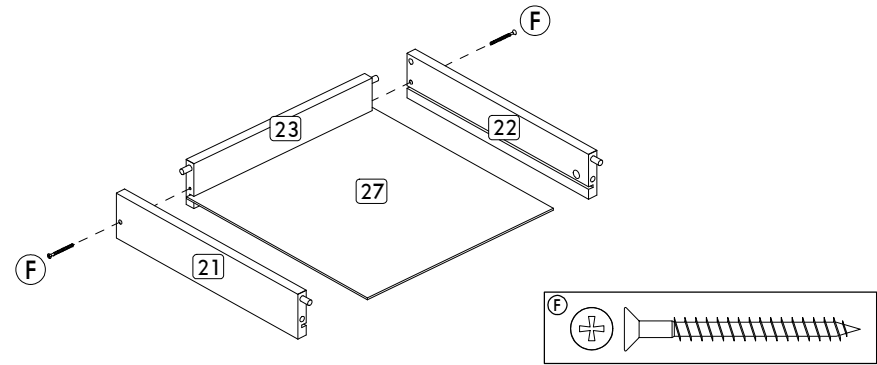

Passo/ Step/ Paso 16

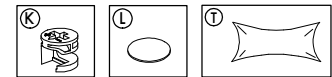
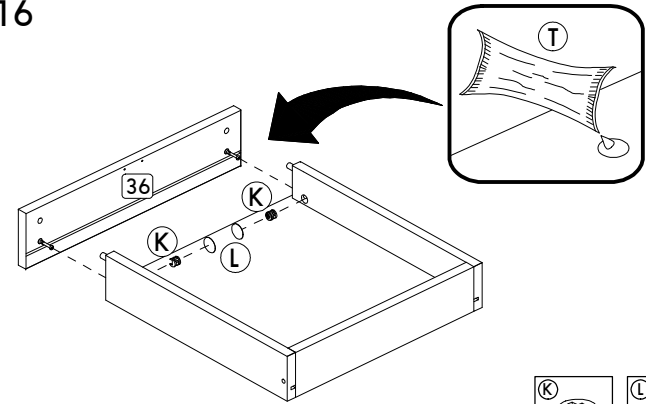

Passo/ Step/ Paso 17

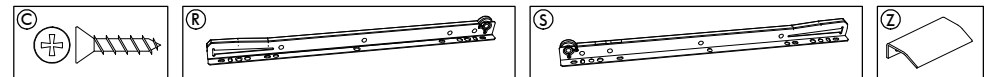
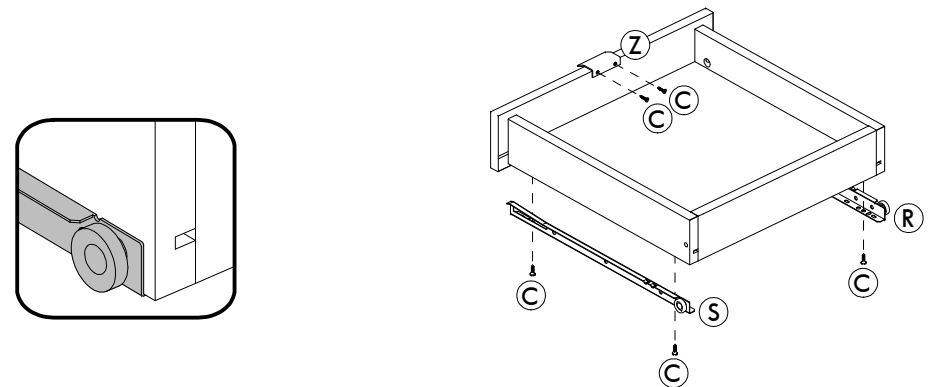



Siga o detalhe abaixo para a fixação dos soquetes no móvel

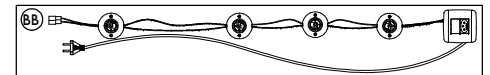
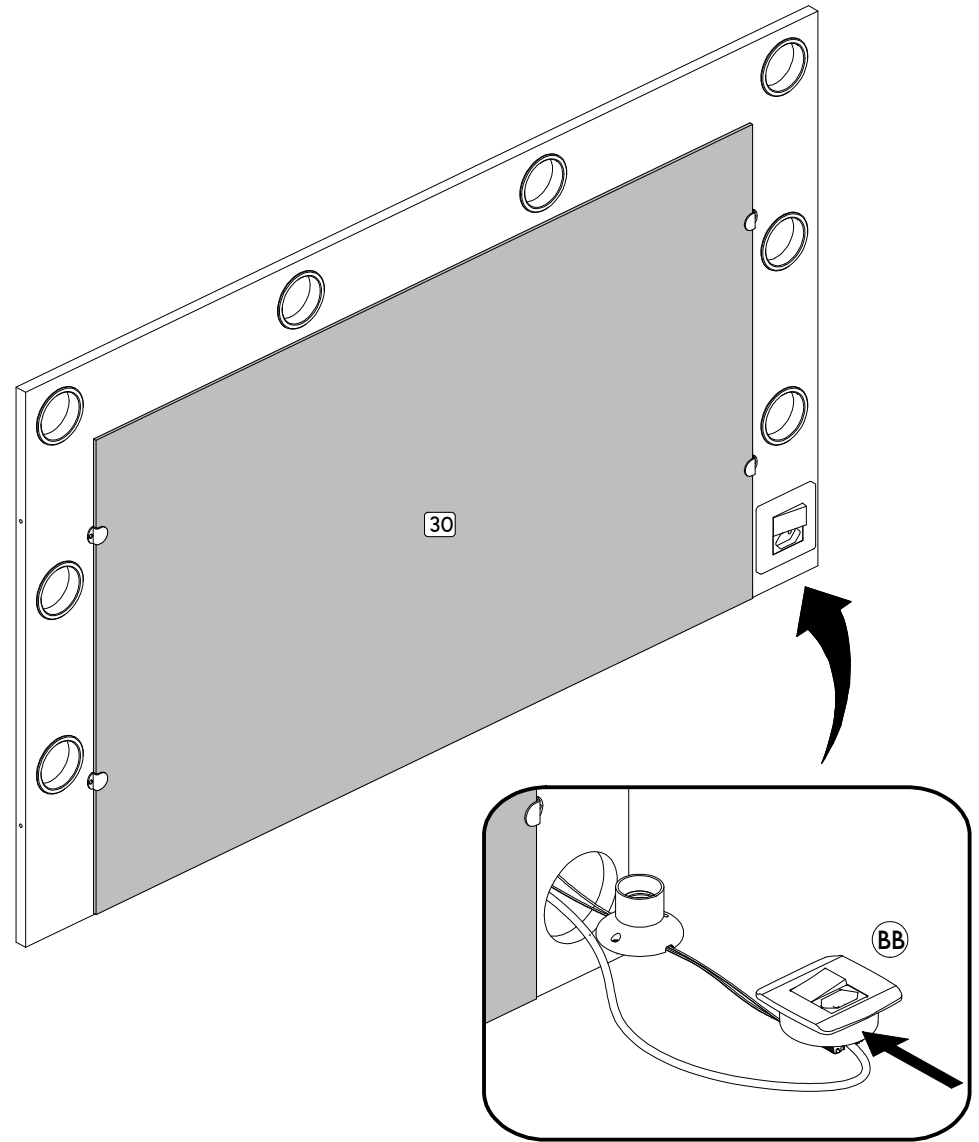
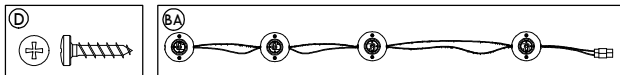
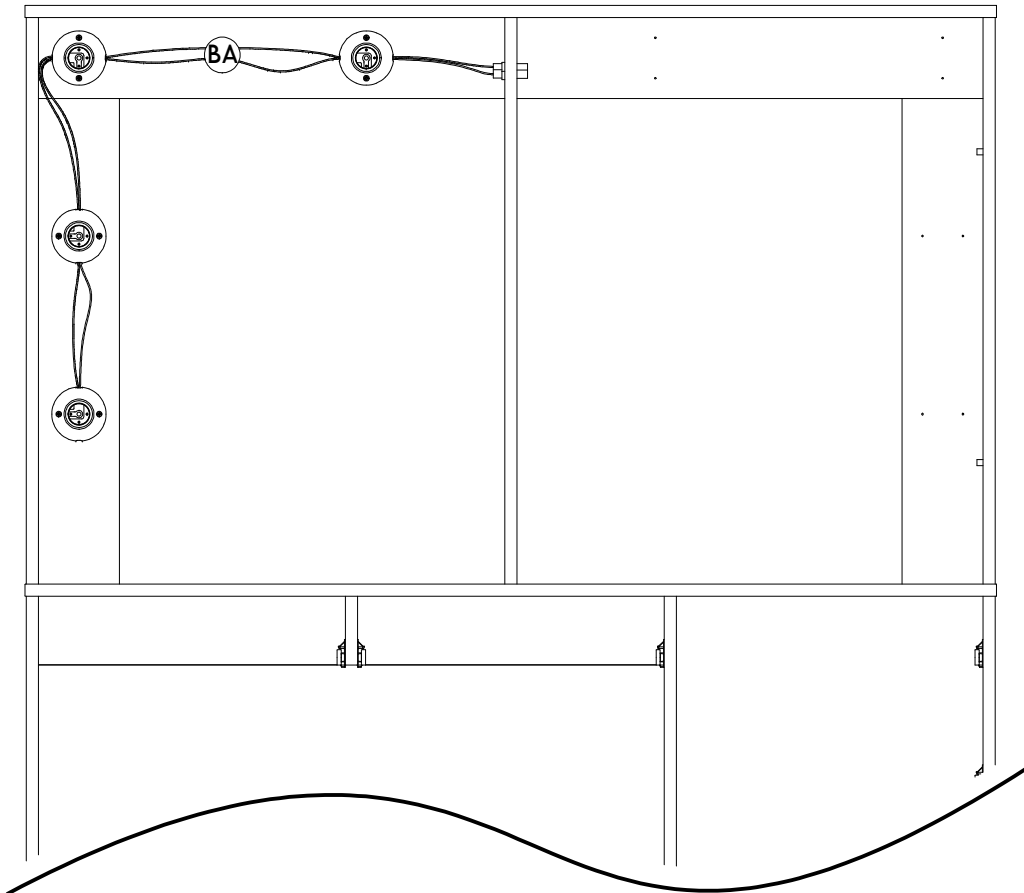
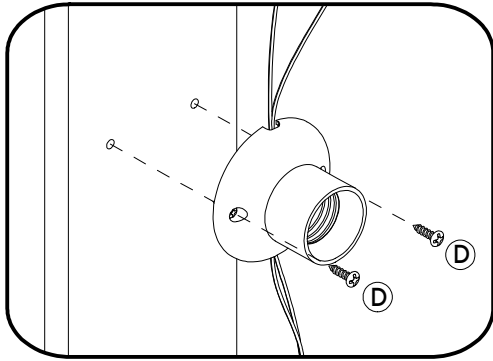

# IMPORTANTE!

Tenha cuidado ao manusear o painel do espelho durante a instalação dos soquetes para que nenhum fio de solte!

