

Sequência de montagem - Assembly Sequence - Secuencia de ensamble.

- 3º Passo

- Pass / Paso

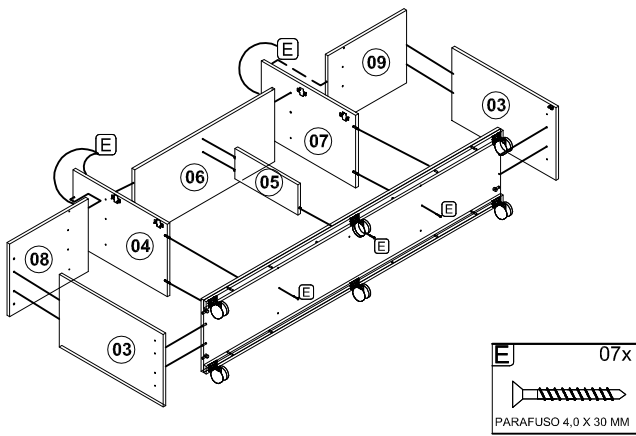

- 4º Passo

- Pass / Paso

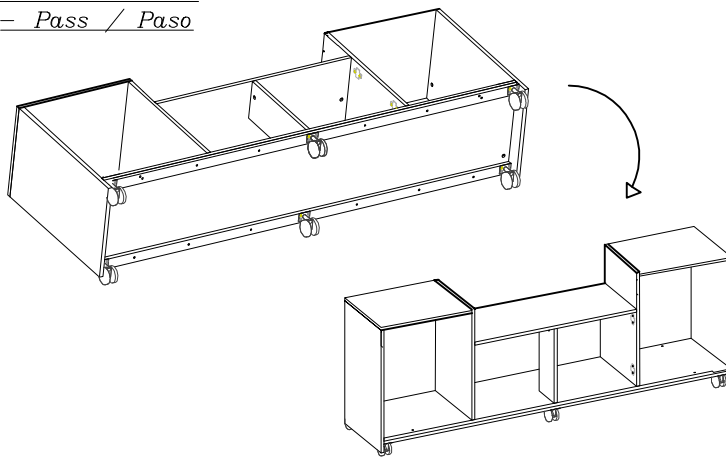

- 5º Passo

- Pass / Paso

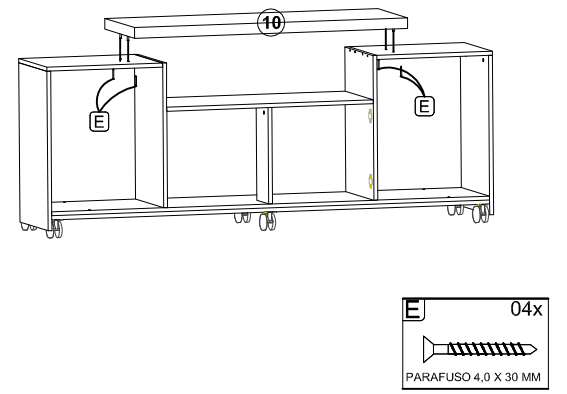

- 6º Passo

- Pass / Paso

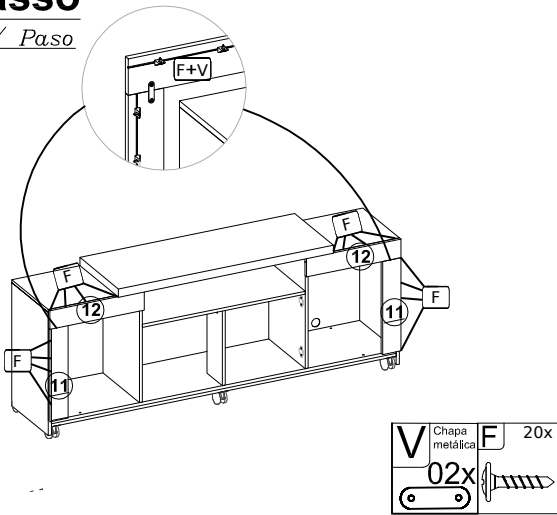

- 7º Passo

- Pass / Paso

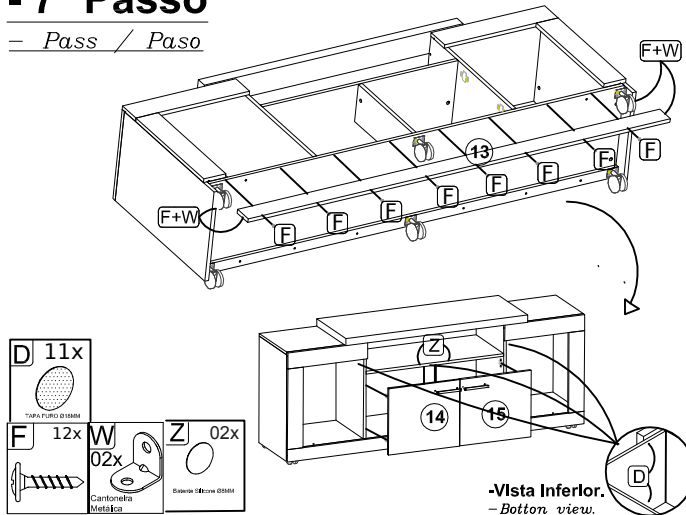

- 8º Passo

- Pass / Paso

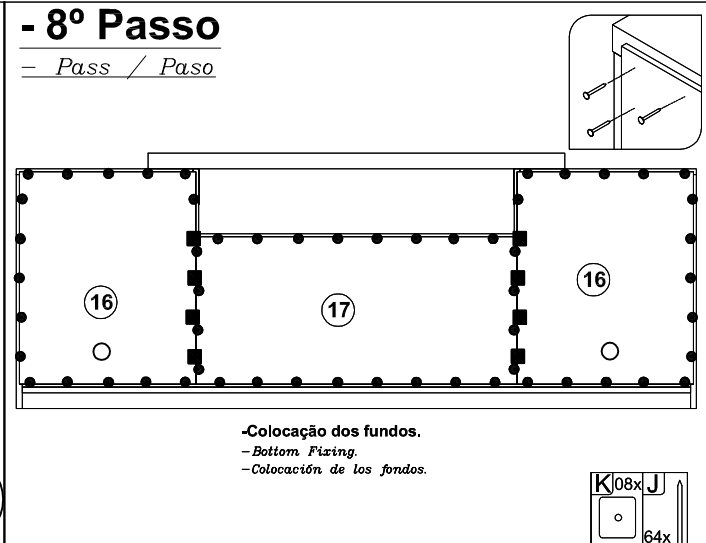

- 9º Passo

- Pass / Paso

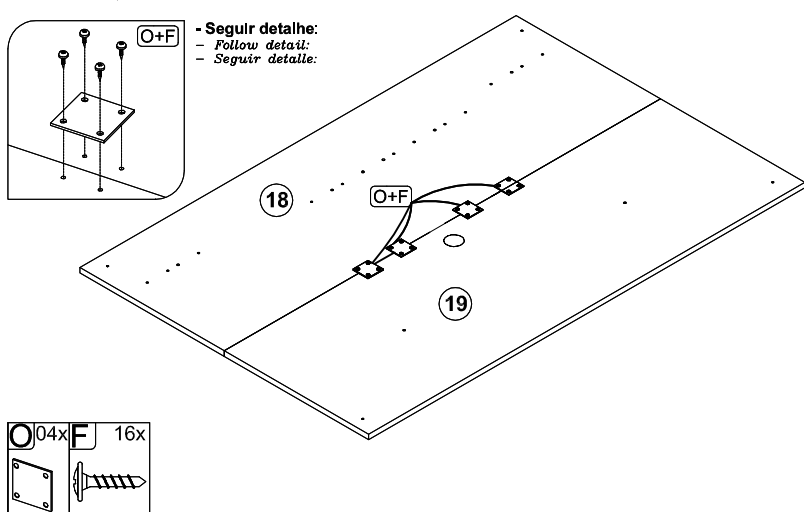

- 10º Passo

- Pass / Paso

Atenção

Atenção / Atención
Sr montador verificar com o Sr cliente as dimensões desejadas do painel montado.
Seguir a marcação existente na peça e escolha a Largura total do Painel conforme Desejado.
- Follow the existent mark on the piece and choose the Overall width of panel.
- Seguir la marcación existente en la pieza y seleccione Anchura total del panel.

- A= 1922mm
- B= 1794mm
- C= 1730mm
- D= 1602mm

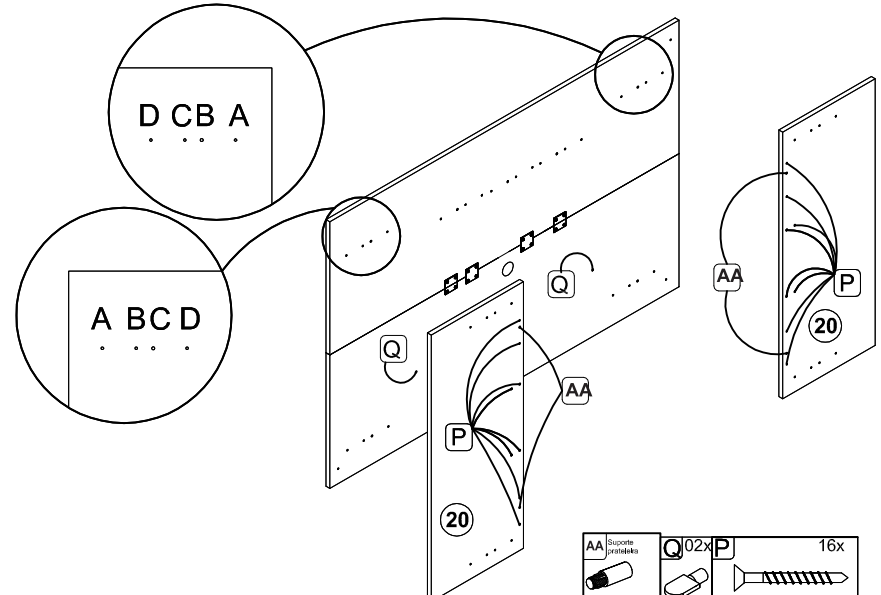

- 11º Passo (Acabamentos)

- Pass / Paso (Finishing / Acabados)

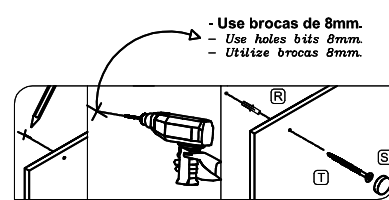
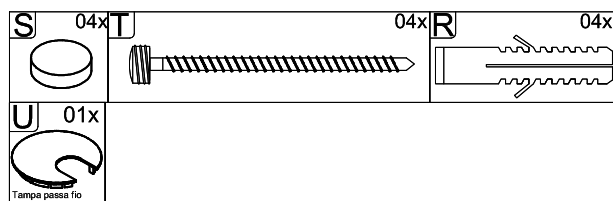
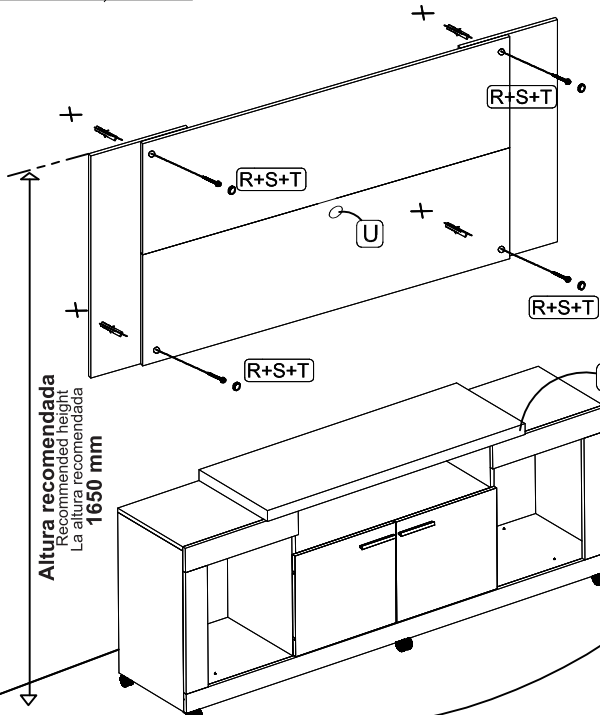

INSTRUÇÕES / Instrucciones

- Utilizar torque baixo na parafusadeira.
- Marque os furos na parede conforme mostra o detalhe para determinar a altura do painel.
- Altura à critério do cliente. Recomendamos que a altura do piso ao topo do Painel seja aproximadamente 1650mm;
- Utilize a furadeira para fazer os furos nos lugares marcados. Ao todo serão feitos 13 furos na parede.
- Coloque as buchas plásticas nos furos e utilize os parafusos conforme o desenho.
- Use minimal force in the screwdriver.
- Mark holes in the wall as shown in detail for determining the height of the panel.
- Customer defines the height. We recommend that the height from floor to the top of the panel be about 1650mm.
- Use the drill to make the holes at the marked locations. Altogether 13 holes are made in the wall.
- Place the plastic bushings in the holes and use the screws according to the drawing.
- Usar poca fuerza en el destornillador eléctrico.
- Como agujeros en la pared como se muestra en detalle para determinar la altura del panel.
- Cliente define el alto. Recomendamos que el alto desde el piso al topo del panel sea cerca de 1650 mm.
- Use el taladro para hacer los agujeros en los puntos marcados. En total 13 agujeros se hacen en la pared.
- Colocar los casquillos de plástico en los agujeros y utilice los tornillos de acuerdo con el dibujo.

-Peso suportado.
- Weight supported.
- Peso soportado.

-Tamanho Máximo TV 55"
- Maximum TV size 55".
- Tamaño máximo de televisor de 55".

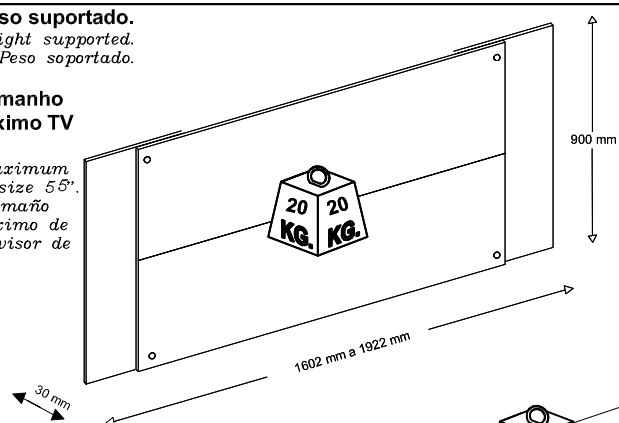

- Aspecto Final

- Final Aspect

- Imagem ilustrativa do aspecto final do produto.
- Illustrative image of the product final aspect.
- Objetos decorativos não inclusos.
- Ornaments not included.
- Decoración no incluida.



- Não apoiar ou sentar no tampo.
- Do not rest or sit on panels.
- NO apoyarse o sentarse em los tableros.

